

Motorized Linear Actuator

baelz 373-E45



BA_373-E45_05_DEF_MJ_2119

Table of Contents	
1. SAFETY	4
1.1 Intended use	4
1.2 Instructions for the operator	4
1.3 Personnel	5
1.4 Before starting work	5
1.5 During operation	5
1.5.1 Transport, installation and assembly	5
1.5.2 Maintenance and repair	5
1.6 Working environment	5
2. PRODUCT DESCRIPTION	6
2.1 Identification	6
1.7 Motorized linear actuator	6
2.2 Technical Specifications	6
2.4 Accessories and options	7
2.3 Type name	7
2.5 Operating conditions	7
3. TRANSPORT AND STORAGE	7
4. ASSEMBLY	8
4.1 Fitting position	8
4.2 Assembly with the valve	9
4.3 Principle of operation	10
4.3.1 Manual adjustment	10
4.4 Electrical connection	11
4.5 Carrying out the electrical connection	11
5. COMMISSIONING	12
5.1 Limit switch settings	12
5.2 Test run	12
5.2.1 Checking the direction of rotation	12
5.2.2 Switching off in end positions	12
6. FITTING THE POTENTIOMETER ASSEMBLY	13
6.1 Installing the potentiometer assembly	13
6.2 Adjusting the potentiometer assembly	14

7. FITTING THE 7020A DIGITAL POSITIONER	15
8. DIGITAL POSITIONER 7020A	19
8.1 Intended use	19
8.2 Operational modes and operating options	19
8.2.1 Standard operation using DIP switches	19
8.2.2 Standard operation using Modbus VT100 or direct addressing	19
8.2.3 Modbus mode	19
8.2.4 Normal and safety modes	20
8.2.4.1 Safety mode: freeze protection and excessive temperature	20
8.2.5 3-point control with a continuous output signal	20
8.3 Wiring diagrams and allocation of connection terminals	20
8.3.1 Wiring diagram	20
8.3.2 Allocation of connection terminals	21
8.4 Configuration of the DIP switches	22
8.4.1 Details on DIP switches	23
8.5 Commissioning	25
8.5.1 Quick start guide	25
8.5.2 Initialization run	25
8.5.3 Meaning of LED signals	26
8.6 Errors	27
8.6.1 Errors after an initialization run	27
8.6.2 Errors during normal positioner operation	28
8.7 Technical Specifications	29
8.8 Accessories and options	29
9. HEATING - RETROFITTING THE HEATING ELEMENT	30
10. SPARE PARTS	31
11. DECOMMISSIONING AND DISPOSAL	32
12. TROUBLESHOOTING	32
12.1 Checklist for operational malfunctions	33
13. DIMENSIONAL DRAWINGS	34

1. SAFETY

Read these operating instructions, in particular the following safety instructions, carefully before installation and operation.



Beware

Beware

Potentially hazardous situation that could result in minor injury.
Also indicates a hazard that may result in property damage.



Caution

Caution

Potentially harmful situation in which the product or an object in its vicinity may be damaged.



Danger

Danger

Imminent danger of death or serious injury.



Warning

Warning

Potentially hazardous situation that may result in death or serious injury.



Tip:

Application instructions and other useful information.

1.1 Intended use

Baelz 373-E45 motorized linear actuators are controlled by three-point control or constant control in combination the digital positioner baelz 7020A. The linear actuators of the series described in this document are intended for the stroke adjustment of valves.

To ensure their intended use, make sure that the above type identification complies with the nameplate of the linear actuators before starting any activities. The actual technical specifications of the linear actuators and the power supply requirements are the specifications indicated on the nameplate.

Any use other than the intended use mentioned above, different tasks, and operation with other power sources than those permitted, is considered to be improper use. In case of improper use, the operator shall be solely liable for the risk presented to persons and the device as well as other property!

Intended use also includes compliance with accident prevention and DIN VDE regulations as well as safe working practices for all measures described in these operating instructions, taking into account the usual technical regulations.

1.2 Instructions for the operator

Always keep the operating instructions available at the place where the actuator is used! During installation, operation and maintenance, observe the applicable occupational safety, accident prevention and DIN VDE regulations. If necessary, observe additional regional, local or internal safety regulations.

Make sure that every person entrusted with one of the measures described in these operating instructions has read and understood these instructions.

1.3 Personnel

Only qualified personnel may work on this linear actuator or in its vicinity. Qualified persons are deemed to be persons who are familiar with the installation, assembly, commissioning and operation or maintenance of the actuators and have the appropriate qualifications for their job. Necessary or prescribed qualifications include, but are not limited to:

- Training / instruction and the authorization to switch electric circuits and devices / systems on and off in accordance with EN 60204 (DIN VDE 0100 / 0113) and the technical safety standards
- Training or instruction in the care and use of appropriate safety and work protection equipment in accordance with safety technology standards.
- First aid training.

Work in a safe manner and avoid any operation that would endanger the safety of persons or damage the linear actuator or other property in any way.

1.4 Before starting work

Before carrying out any work, check whether the types specified here correspond to the information on the name plate of the actuator:

baelz 373-E45

1.5 During operation

Safe operation is only possible if transport, storage, assembly, operation and maintenance is carried out in a safe, proper and professional manner.

1.5.1 Transport, installation and assembly

Observe the general installation and safety regulations for heating, ventilation, air conditioning and piping systems. Use tools only for their intended purpose. Wear the required personal and other protective equipment.

1.5.2 Maintenance and repair

Prior to maintenance or repair, make sure that the linear actuator is disconnected from power by qualified personnel in accordance with DIN VDE standards. The linear actuator requires little maintenance. We recommend lubrication of the gear with grease (Klüber Microlube GL 261) every 6 months and simultaneous removal of any deposits on the spindle. This requires removal of the actuator cover. Apart from this, the actuator does not require any other routine or periodic maintenance.

1.6 Working environment

Note the information on working environment in the technical specifications.

2. PRODUCT DESCRIPTION

2.1 Identification

Each actuator has a nameplate showing specifications regarding the maximum operating conditions of the device and a unique, order-related serial number (F no.).

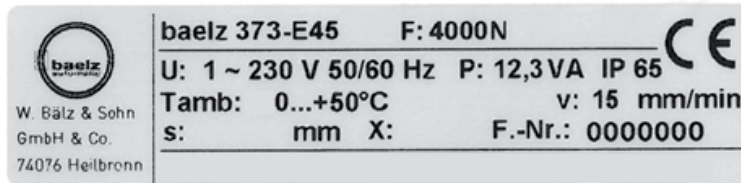

Fig. 1: Baelz nameplate for motorized actuators

1.7 Motorized linear actuator

The baelz 373-E45 is a motorized linear actuator with load-dependent limit switches for flow control applications. The actuators are designed for highly accurate positioning in an industrial environment. They come complete with a manual adjustment device and a wide range of options and additional extras are available.

2.2 Technical Specifications

Table 1. Technical Specifications, baelz 373-E45		
Actuating force	kN	4,0
Positioning speed ¹⁾	mm/min	15
Power consumption (230 V)	VA	11
Nominal current (230 V)	A	0.045
Type of motor		synchronous motor (syn)
Motor protection		stall-proof motor (B)
Maximum stroke	mm	44
Supply voltage ²⁾		24 V / 115 V / 230 V 50/60 Hz ± 10 %
Operating mode acc. to IEC 34-1		S1 - 100 % S3 - 30 % duty cycle 1200 c/h
Cable glands		3x M20 x 1.5
Electrical connection		internal terminal block, see wiring diagram for terminal allocation
Limit switches		2 load-dependent limit switches, max. 250 V AC, ohmic load: max. 5 A, inductive load: max. 3 A
Fitting position		as required, but not "head down" with the actuator below the valve
Ambient temperature	°C	0 to +50
Gear lubricant		Klüber Microlube GL 261
Position indicator		position of spindle coupling relative to indicator marks on yoke
Manual adjustment		crank handle
IP-rating according to EN 60529		IP 65
Trapezoidal thread		Tr 14 x 3
Connection type		yoke S21 / S21-L / S41
Weight, approx.	kg	8.0

1) At 60 Hz the positioning speed and power consumption both increase by 20 %.

2) Other supply voltages available upon request. Configuration options are indicated in the Baelz price list.

2.4 Accessories and options

Table 2. Options for Actuators	
2EZ-Fg	Two additional limit switches for signalling end positions or intermediate positions, freely adjustable, max. 250 V AC, rating for resistive load max. 5 A, for inductive load max. 3 A and 200 Ω / 1 kΩ / 5 kΩ potentiometer, linearity error ≤ 0.5%, max. 1.5 W, contact current 30 mA, stroke reduced by [%ohm x actual stroke/44] mm, depending on valve stroke
7020A	Digital positioner for actuator control, self adapting 1 input signal: 0(2)...10 V, 0(4)...20 mA or (3-point) 2 output signals: 0(2)...10 V and 0(4)...20 mA 1 digital input, 2 relays for feedback on end or intermediate positions, Interface RS485 Modbus RTU, incl. 5 kΩ potentiometer
Hgz	Heating resistor with thermoswitch against moisture with automatic temperature regulation, max. 15 Watts, supply voltage 24, 115, 230 V 50/60 Hz

2.3 Type name

baelz 373	-	E45	-	40	-	15	-	S21
motorized linear actuator		actuator type		thrust		positioning speed		yoke type

2.5 Operating conditions

In case of extreme variations in ambient temperature and high humidity levels, installation of a heating resistor is recommended to minimise condensation in the actuator.

Actuator covers with suppression of thermal bridges (dual covers) are recommended.

- Connect the heating element (HZG) as shown in the wiring diagram.
- Put the device into service as soon as it is installed.

The actuators are suitable for installation in industrial plants and in waterworks and power plants with a low pollutant concentration.

For use outdoors or in an environment with a high pollutant concentration, such as heavy traffic areas, industrial areas (chemical plants, sewage plants, etc.), coastal areas and the open sea, the actuators must have external parts made of non-corrosive material and must be provided with a special coating.

When used outdoors, the actuator must be protected with an additional cover against

- rain
- direct sunlight
- strong draughts
- dust

3. TRANSPORT AND STORAGE



Caution

Risk of injury caused by failure to observe safety regulations!

- Wear the required personal and other protective equipment.
- Protect the linear actuator from impact, shock, vibration and similar influences.
- Store the linear actuator (or the complete actuator/valve assembly) in a dry place.
- Observe the transport and storage temperature limits of -20 to +60°C.

4. ASSEMBLY



Attention

Make sure that the specifications on the nameplate correspond to those in the order documents!

4.1 Fitting position

When fitting with the connecting rod in horizontal position, fit the linear actuator such that the sides of the yoke are positioned one above the other in the vertical plane.



Caution

Risk of damage if no valve is fitted to actuator!

Caution:

- If the linear actuator is operated without a valve, the missing stop may cause damage to the actuator. The actuator must therefore **never be operated without a valve**.
- Allow for about 200 mm space above the cover at the site of installation.
- Check the work environment before fitting the actuator and putting it into operation:
- Make sure that the valve is correctly installed. For detailed information, refer to the valve's installation instructions.
- Determine the mounting position of the linear actuator. Do not mount linear actuators "head down" below the valve.

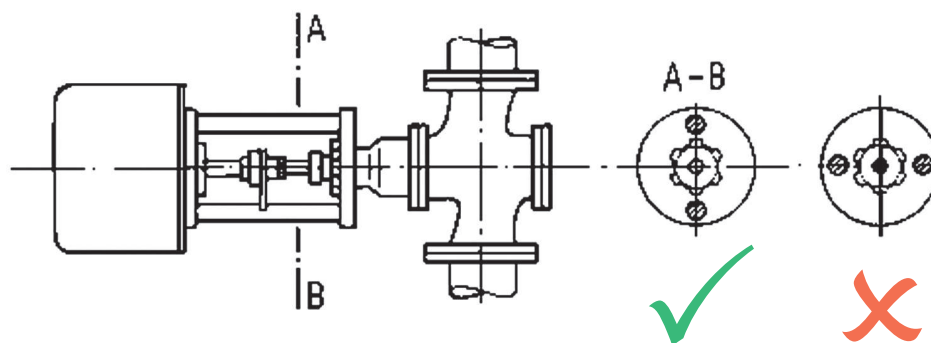

Fig. 2: Fitting position

4.2 Assembly with the valve

Prior to assembly, check that:

- the operating conditions comply to the specifications of the linear actuator.
- the valve is complete (yoke on actuator or on valve).
- the connections on valve and actuator match.

The linear actuator is supplied with the spindle retracted.

A slight adjustment for fitting of the coupling can be carried out by turning the spindle. The following dimensions must be adhered to, otherwise damage to the actuator can ensue.

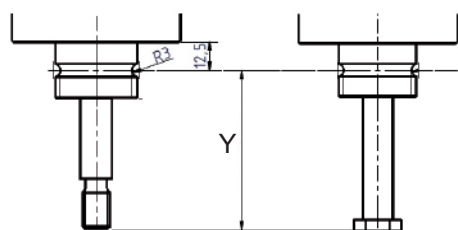

Y = max. 88,5 mm
min. 46,5 mm

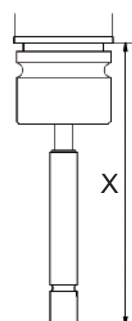

X = max. 188 mm
min. 142 mm



Attention

Keep the spindle within the given stroke range to avoid damage to the actuator!

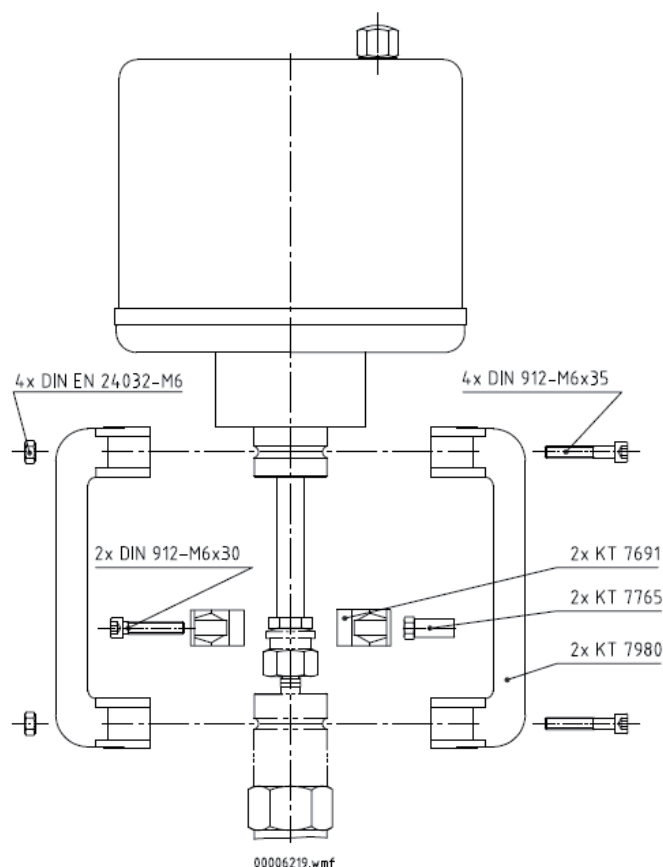

Fig. 3: Assembly with the valve

Ensure that the connecting rod of the actuator and the valve spindle are correctly aligned. Misalignment can lead to power loss and premature wear.

When supplied with integrated potentiometer assembly, adjustment of the assembly may be necessary.

4.3 Principle of operation

Motorized linear actuators to operate control valves for flow regulation applications in control and process technology. The self-locking threaded spindle/spindle nut is driven by an electric motor via a gearbox. This converts the rotary movement into a linear movement. Load-dependent limit switches dictate the end positions

4.3.1 Manual adjustment

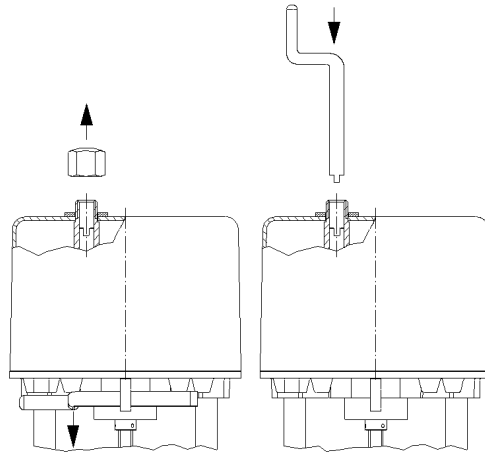

Manual adjustment may only be carried out when the motor is not in motion. For the adjustment, unscrew the cap nut from the top of the cover, remove the hand crank from the bracket on the bottom of the actuator housing and insert it into the tube in the top of the cover. Turn the crank handle using gentle pressure.

4.4 Electrical connection



Risk of electric shock!

Danger

Use an appropriate power supply to ensure that no hazardous voltage can enter the device during normal operation or in the event of a system failure or defective system components.

Failure to heed this warning may result in death, serious injury or substantial material damage.

For short-circuit protection and disconnection of the actuator from the power supply, fuses and switch disconnectors must be provided on site. The current values for the rating depend on the operating current of the motor (refer to the nameplate).

The electrical connection should only be carried out by trained, qualified personnel.

- Prior to connection, observe the instructions in this chapter.
- After connection, but before applying voltage, observe the instructions in the chapter "Commissioning" (page 12).
- When making the electrical connection, be sure that the power supply is turned OFF! Ensure protection against unintentional reconnection to the power supply!
- For wiring and connection, observe the regulations for the construction of electric power installations and the regulations of the local energy supplier!
- Check compliance of the supply voltage and frequency with the specifications on the nameplate of the actuator and on the nameplate of the actuator motor.
- Always select the cable cross section so as to match the actuator's power consumption and the required cable length. Minimum cross section of the cable for this linear actuator: 1 mm²

In case of malfunction:

Dangerous voltage if protective earth conductor is NOT connected! Risk of electric shock!

→ Do not operate the device if the protective earth conductor is not connected!

Trapped wires can lead to short circuiting! Risk of electric shock and malfunction.

4.5 Carrying out the electrical connection



Risk of electric shock!

Danger

→ Disconnect the device from the power supply before removing cover.

Always use the wiring diagram on the inside of the cover or supplied with the actuator.

Replace the dummy plugs with cable glands.

1. Strip the cable as necessary.
2. Strip the ends of the individual wires.
3. For flexible wires: Use wire end ferrules as specified in DIN 46228.
4. Connect the wires as shown in the job-specific wiring diagram.

The IP-rating shown on the nameplate is only valid if suitable cable glands are used.

5. COMMISSIONING

Compare the thrust of the actuator and the set travel with the valve specifications. Overloading can result in severe damage to the valve.

Pay attention to moving parts during fitting and adjustment. Risk of injury and substantial material damage.



Attention

Actuators which are supplied fitted with a valve are set to the appropriate valve stroke length. When an actuator with a 7020A digital positioner is fitted to a valve, an initialization run must be carried out to set up the actuator according to the valve type.

5.1 Limit switch settings

By default, the actuator is switched off in the end positions by the "DE" switches (wiring diagram, Fig. 9, page 21). These are factory-set to the force indicated on the nameplate.

5.2 Test run

5.2.1 Checking the direction of rotation

- Adjust the actuator manually to roughly the middle position.
- In direction of travel CLOSE, switch the actuator on and watch the direction of rotation.
- If the direction of rotation is wrong, switch off immediately.
- Check wiring (jumpers).
- Repeat the test run.



Attention

If the direction of travel is set incorrectly, damage to actuator and valve is imminent as the limit switches will not function with the wrong direction of rotation!

5.2.2 Switching off in end positions



Danger

Risk of electric shock!

If the switches in the actuator are not factory-wired, check proper switching off in end positions: ***With the cover removed, the linear actuator may only be operated briefly for test runs or when performing absolutely essential adjustments on electrical components, such as potentiometer, limit switches or positioning electronics.***

While performing this activity, there is unobstructed access to hazardous, live, exposed, moving and rotating parts. Adjustments performed incorrectly or without exercising the necessary caution may result in death, serious injury or substantial material damage. Any operation of the linear actuator with the cover removed for a purpose other than that described above is prohibited.

Use an insulated screwdriver to actuate the switching rollers of the DE switches as shown in the wiring diagram, Fig. 9, page 21, and check that the each switch actually switches off the motor. If necessary, change the motor supply jumpers.

6. FITTING THE POTENTIOMETER ASSEMBLY



Danger

Disconnect actuator from power supply before starting work!

6.1 Installing the potentiometer assembly

Fit the distance sleeve (4) onto the threaded end of the connecting rod and tighten. Place the laminate washer (2) over the threaded end onto the self-locking nut. Insert the position detector for the potentiometer assembly (3) ensuring it engages in the slot provided on the toothed rod.

Screw another laminate washer (2) and self-locking nut (1) onto the threaded insert and slightly tighten the nut

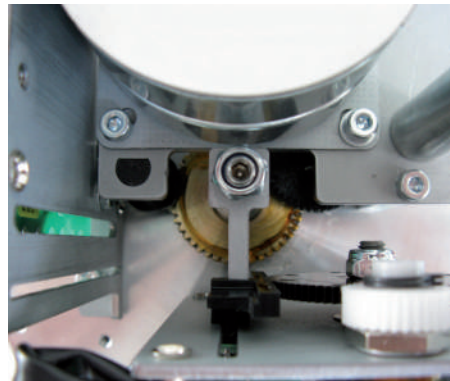
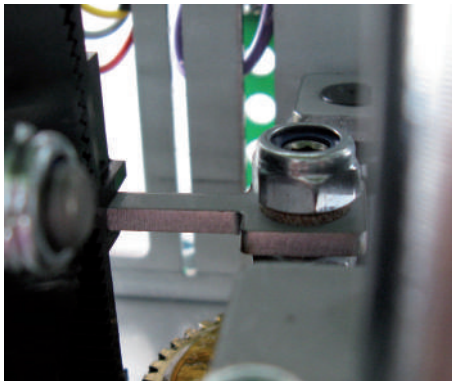
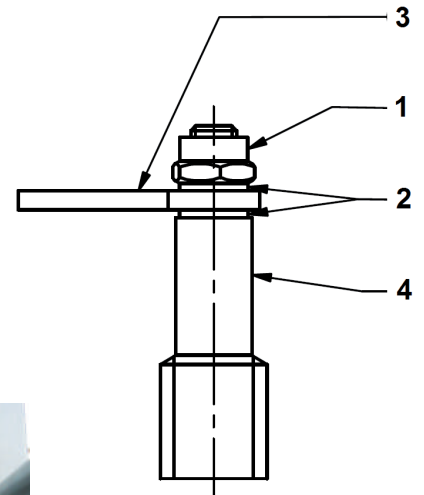

The potentiometer assembly can then be fitted (1) and secured with the screws provided (2)

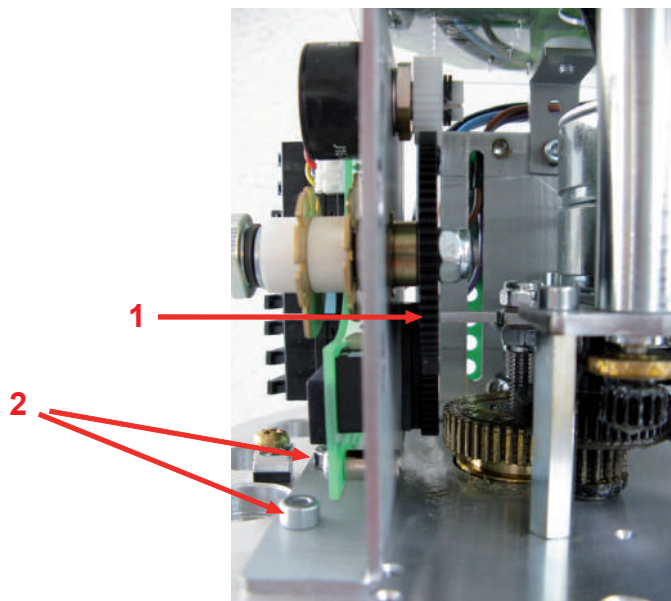

Fig. 4: Fitting the potentiometer assembly

6.2 Adjusting the potentiometer assembly

1. The potentiometer can be set to the defined zero point using the screw slot on the rear (for normal mode clockwise up to the mechanical stop). For valve stroke < 44 mm, note that for reverse mode, the potentiometer must be turned to the new zero point (mechanical stop opposite). For this adjustment the actuator spindle must be in the correct end position:

Normal mode: zero point = spindle extended --> potentiometer fully clockwise

Reverse mode: zero point = spindle retracted --> potentiometer fully anticlockwise

2. The additional limit switches can be adjusted by loosening and retightening the knurled nut and setting the contact washers to the desired position.

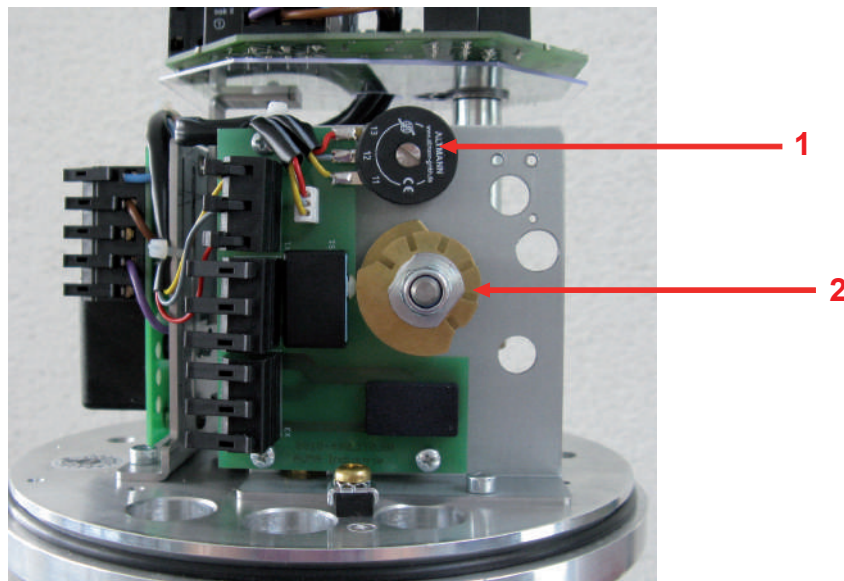

Fig. 5: *Adjusting the potentiometer assembly*

7. FITTING THE 7020A DIGITAL POSITIONER



Danger

Disconnect actuator from power supply before starting work!

These instructions apply, given that the potentiometer assembly has been correctly fitted as described in section 6.1.

- Remove the extension and the brass sleeve.

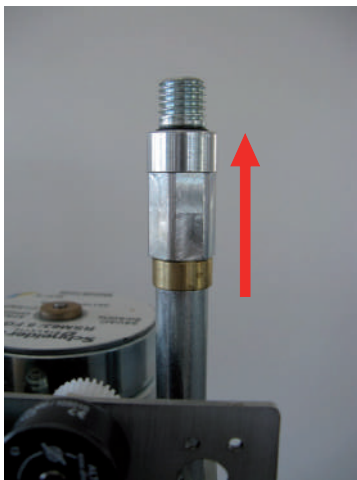

- Insert the M4 x 5 mm screw into the limit switch plate, but do not tighten it. Put the bracket in place. Now tighten the screw.

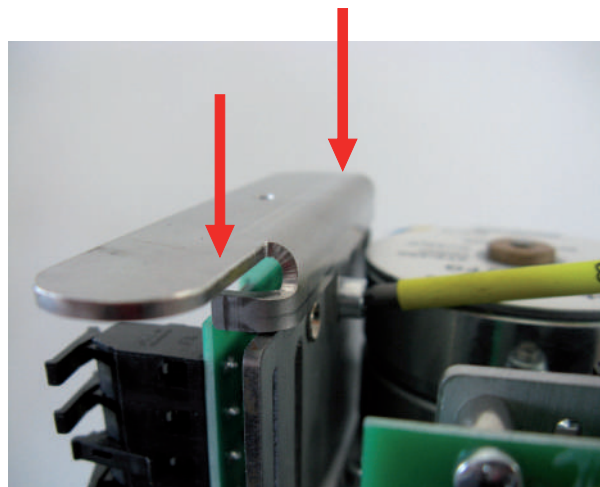

- Before fitting the adaptor panel, the nameplate must be stuck to the underside. If the digital positioner board is replaced, this nameplate must also be changed.



- Place the 4 click-fit spacer connectors on the adaptor panel.

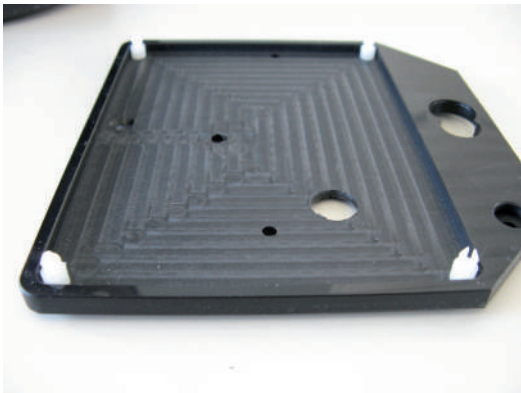

- Fit the adaptor panel over the threaded end of the extension so that it rests on the bracket.

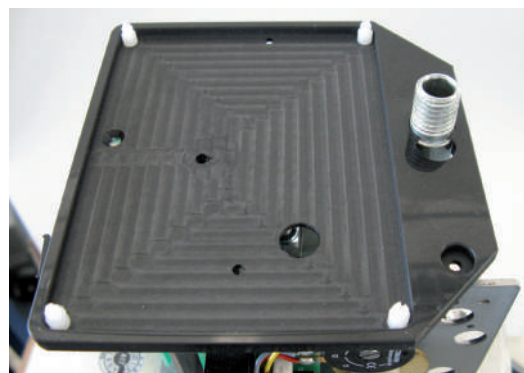
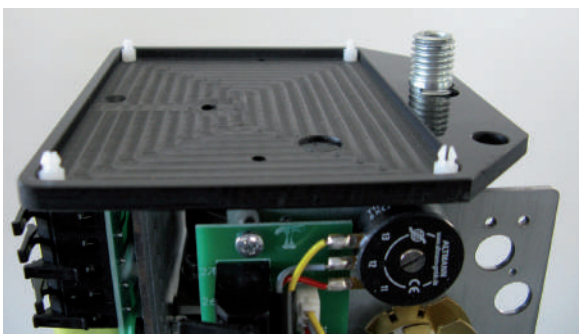

- Fit the spacer sleeve onto the thread and screw the extension on.

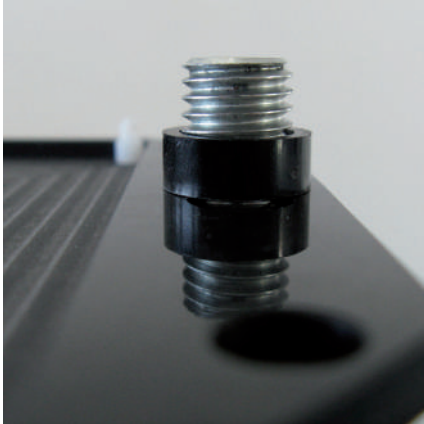

- Adjust the adapter panel on the bracket so that the countersunk hole and the hole in the bracket are aligned. Insert the plastic screws and fit and tighten the nuts on the underside of the bracket.



- Mount the digital positioner board onto the click-fit spacer connectors. The transformer should be on the same side as the potentiometer.



- Wire up the digital positioner board with the motor and the potentiometer according to the wiring diagram 7020A, Fig. 9, page 21.

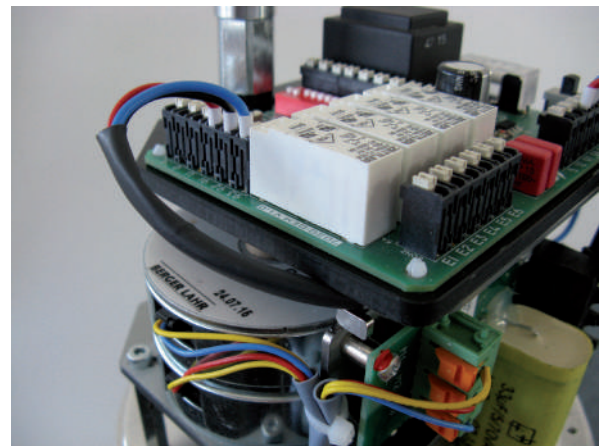
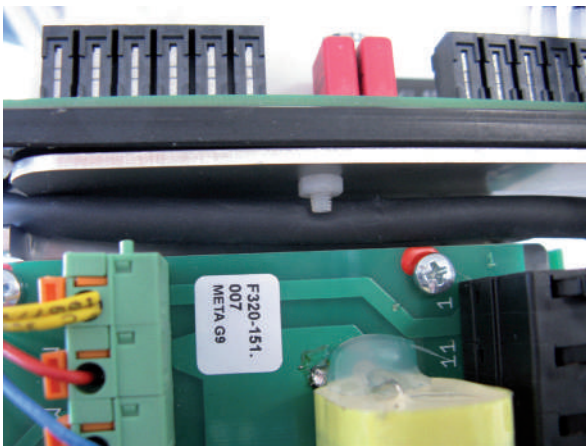
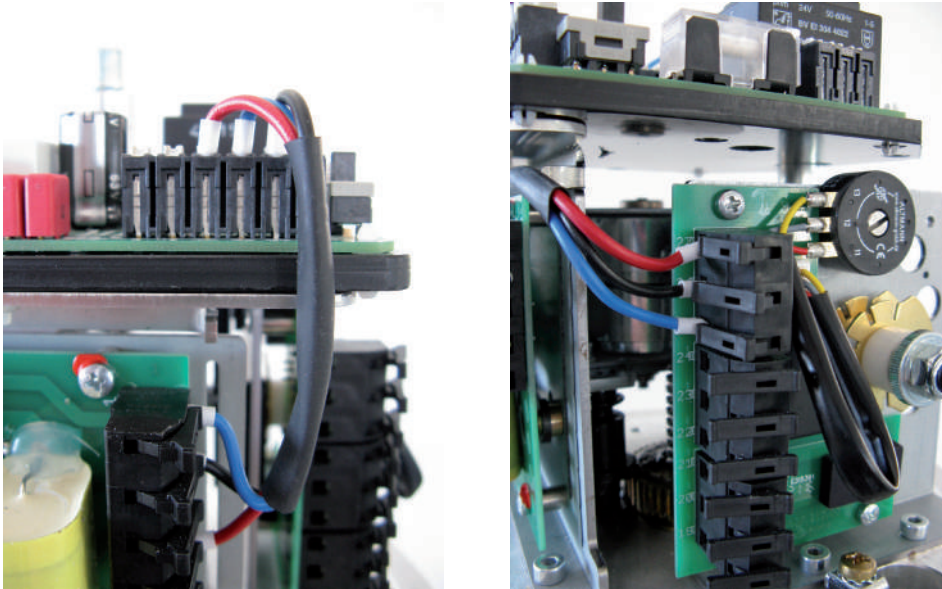

- Stick the wiring diagram to the inside of the actuator cover. Please note the digital positioner type - in this case "7020A" - on the actuator nameplate under "X:".

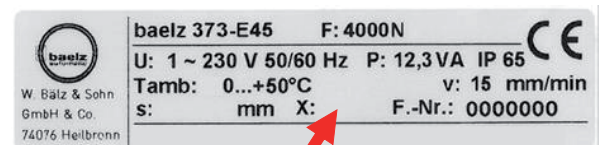

8. DIGITAL POSITIONER 7020A

8.1 Intended use

The digital positioner **baelz 7020A** controls the actuator according to the value of the control signal: 0(2)-10 V, 0(4)-20 mA

To ensure use for the purpose intended, check that the above type identification corresponds to the nameplate on the positioner before starting any activities. The technical specifications of the positioner and the power supply requirements are the indicated on the name plate. Any use other than the intended use stated above, use for different tasks, and operation with other power sources than those permitted, is considered to be improper use. In case of improper use, the operator shall be solely liable for the risk presented to persons and to the device as well as to other property!

The intended use also comprises compliance with the accident prevention regulations and the DIN VDE standards of the German Institute for Standardization and the Association for Electrical, Electronic & Information Technologies. It also implies working in accordance with the safety requirements when performing all activities described in these operating instructions, under consideration of general technical rules and regulations.

8.2 Operational modes and operating options

 **Tip:** For further information and additional functions, see *baelz 7020 operating instructions*.

8.2.1 Standard operation using DIP switches

The DIP switches can be used to carry out standard configurations and operations (see section 8.4).

When DIP switch 11 is set to 0, the 7020A is in the standard operational mode.

In standard mode, all DIP switches are active and the functions of the Baelz 7020A can be individually adapted. Functions which are predefined and unalterable in standard mode are described in chapter 6.1 of the baelz 7020 operating instructions.

8.2.2 Standard operation using Modbus VT100 or direct addressing

In standard mode, the Baelz 7020A can be operated using Modbus VT100. For this, a virtual 7020A display and a virtual 7020A keypad are transmitted to a user interface. Modbus direct addressing, e.g. from a building automation system, enables access to status information and allows operation and configuration. (See baelz 7020 operating instructions, Appendix A). The settings given by the DIP switches remain active. Values which are only relevant in Modbus mode can be adjusted in standard mode, but only take effect in Modbus mode.

8.2.3 Modbus mode

When DIP switch 11 is set to 1, the Baelz 7020A is in Modbus mode. In Modbus mode, the 7020A is at its most flexible and can be configured and operated using either a Modbus VT100 or Modbus direct addressing, for example in a building automation system. See separate operating instructions "Baelz 7020 Digital Positioner - Operating Instructions for Modbus mode"

8.2.4 Normal and safety modes

In normal mode the position of the valve is controlled by the set value at analogue input AI2. The N↔S switch shown in the picture on the right is set to normal mode (N). In normal mode, no external control systems can be connected to terminals 12 and 14.

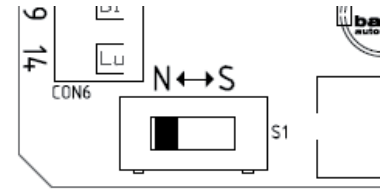

Fig. 6: N↔S-switch

8.2.4.1 Safety mode: freeze protection and excessive temperature

In safety mode the actuator can be sent to a safe position (extended / retracted, depending on the direction of action of the valve) in case of failure or malfunctioning of the microcontroller.

To operate the Baelz 7020A in connection with an external freeze protection and/or excessive temperature thermostat, set the N↔S switch to safety mode (S).

Connect the freeze protection and/or excessive temperature thermostat according to desired function and priority. Be sure to take the direction of action into account! See wiring diagrams in the baelz 7020 operating instructions.

8.2.5 3-point control with a continuous output signal

1. Set the positioner up and wire to power supply as described previously and initialize as described in section 8.5.2.
2. To deactivate the error signal, if desired, set the DIP-switch 11 to 1 ("ON") and change the following values in the menu item "CA" using WinBas Tools (on PC, see baelz 7020 operating instructions):
 - AD to 0
 - EFP to 0.0%
 - LA to 1

(If you don't mind the red LED error signal, step 2 can be left out completely. This has no effect on the function of the positioner.)

3. Set the N↔S switch (Fig. 6) to "S" and wire as shown in Fig. 7 (the positioner must remain connected to the power supply throughout).
4. The required signal can now be picked up on AO1 and AO2.

IMPORTANT NOTE: Before any further re-initialization of the device, disconnect terminals 12 and 14 and set the N↔S switch to normal operation (N).

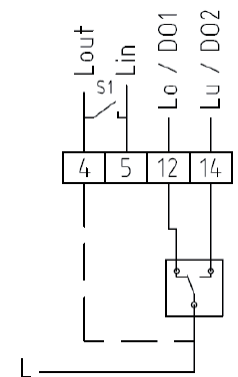

Fig. 7: Wiring diagram 3-point-signal

8.3 Wiring diagrams and allocation of connection terminals



Danger

Disconnect actuator from power supply before starting work
See also section 4.4.

8.3.1 Wiring diagram

Fig. 8: Wiring diagram basic actuator

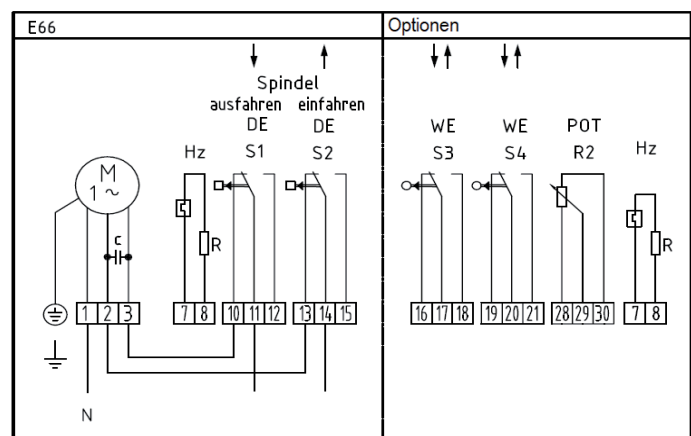

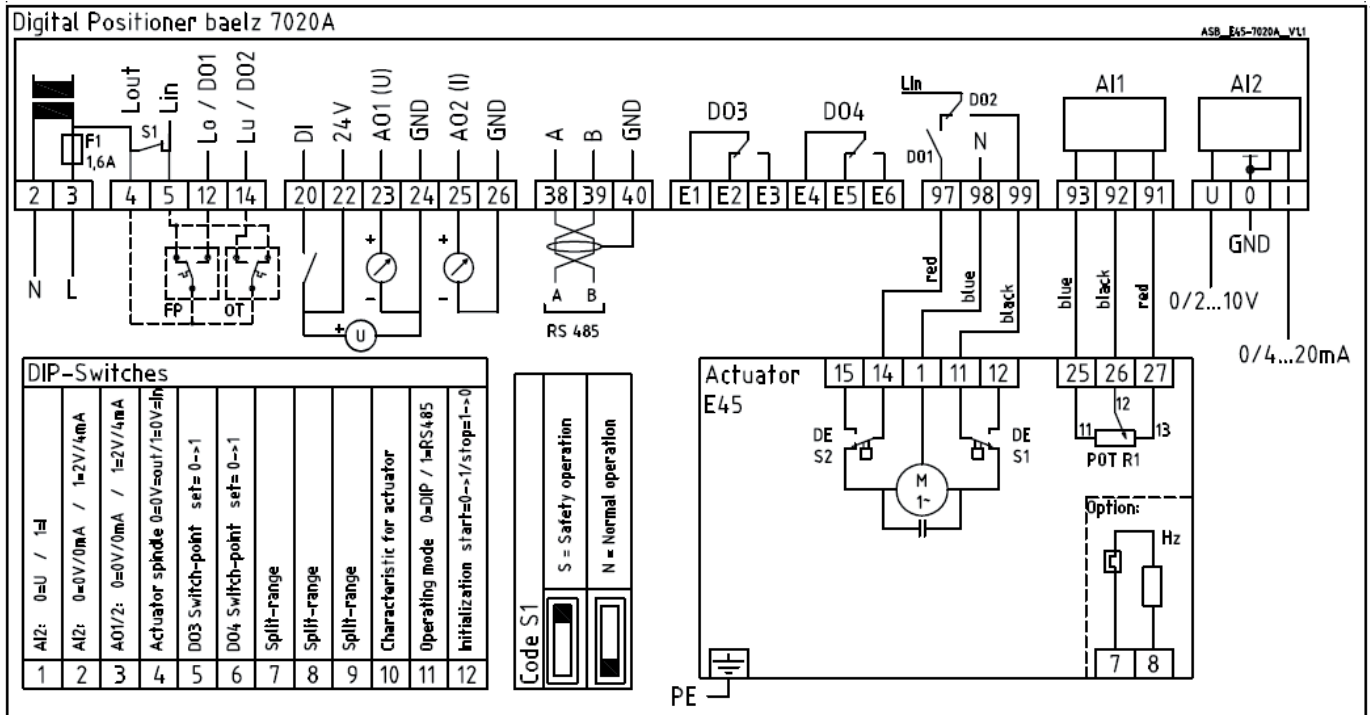
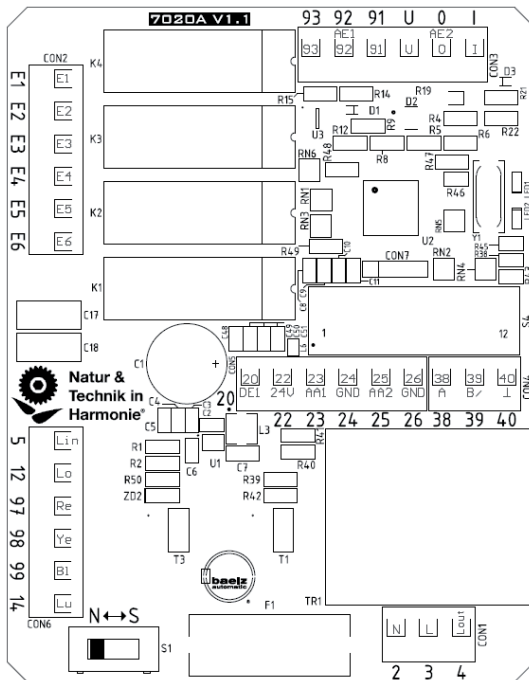

Fig. 9: Wiring diagram with digital positioner baelz 7020A

8.3.2 Allocation of connection terminals





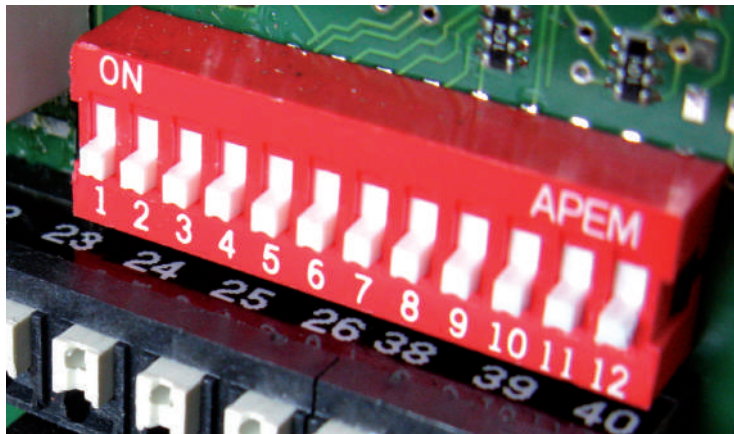

Terminal	Allocation	Notes
2, 3	supply terminals	See wiring diagram for correct allocation.
4, 5, 12, 14	Can be allocated to an overriding external control system (freeze protection, excessive temperatures).	For external control, the N↔S switch must be set to „S“ (safety mode).
20, 22	Digital input for a switch used to select between two conditions, e.g. „open / closed“ or „summer / winter“.	
23, 24, 25, 26	Analogue output position indicator using voltage and / or current.	Analogue outputs can be connected simultaneously.
38, 39, 40	Connection terminals for Modbus	
91, 92, 93	Connection terminals for potentiometer	
U, 0, I	Input setpoint value for valve position	IMPORTANT! Position of DIP switch 1, see section 8.4
E1, E2, E3, E4, E5, E6	Terminals for 2 digital outputs	IMPORTANT! Position of DIP switches 5 & 6, see section 8.4
97, 98, 99	Connection terminals for motor	Ex-works wiring varies according to type of actuator

BA_373-E45_05_DEF_MJ 2/19

8.4 Configuration of the DIP switches



The factory setting of the DIP switches is position 0, as shown.

Switch	Function	Position 1 "ON"	Position 0 
DIP 1	Set value input: voltage, V or current, mA?	current, mA	voltage, V
DIP 2	Set value input starting at 0 V / 0 mA or 2 V / 4 mA?	2-10 V / 4-20 mA	0-10 V / 0-20 mA
DIP 3	Analogue output starting at 0 V / 0mA or 2 V / 4 mA?	2-10 V and / or 4-20 mA	0-10 V and / or 0-20 mA
DIP 4	Direction of control action: valve closed with drive spindle extended or retracted?	Drive spindle retracted → valve closed	Drive spindle extended → valve closed
DIP 5	Current position of the actuator is saved as additional switching position "2EZ-1". See wiring diagram, page 21.		from 0 to 1 → save "2EZ-1"  = 2%
DIP 6	Current position of the actuator is saved as second additional switching position "2EZ-1". See wiring diagram, page 21.		from 0 to 1 → save "2EZ-2"  = 98%
DIP 7, 8, 9	These 3 DIP switches define the function: linear / split range / 11-point / inverted		s. Fig. 11, page 24  = linear
DIP 10	Defines valve characteristic using actuator characteristic, see page 24.	Actuator characteristic inverse equal percentage, valve action linear	Actuator characteristic linear, valve action equal percentage
DIP 11	Selects standard or Modbus mode.	Modbus mode	standard mode
DIP 12	Starts initialization run. Set back to 0 after initialization (s. section 8.5.2)		from 0 to 1 → starts initialization run
N↔S	Selects normal or safety mode	position "S" = safety mode	position "N" = normal mode

 factory setting

Fig. 10: Setting the DIP switches

8.4.1 Details on DIP switches

DIP1 and DIP2:

are interpreted together:

DIP1: 0 = voltage → DIP2: 0 = 0-10 V or 1 = 2-10 V.

DIP1: 1 = current → DIP2: 0 = 0-20 mA or 1 = 4-20 mA.



Attention

Either a voltage source can be connected to the U-terminal or a current source to the I-terminal. Never connect both at the same time.

DIP3:

DIP switch 3 configures the analogue outputs AO1 and AO2 (see wiring diagram, Fig. 9, page 21). DIP switch 3 defines the scaling of the two analogue outputs. When DIP 3 = 0, AO1 is set to 0-10 V and AO2 to 0-20 mA (factory setting), when DIP 3 = 1, AO1 is set to 2-10 V and AO2 to 4-20 mA. In Modbus mode AO1 and AO2 can be configured separately.



Tip:

Using 2-10 V / 4-20 mA enables clear identification of a loss of signal (= 0 V / 0 mA).

DIP4:

DIP switch 4 changes the direction of operation of the actuator.

The direction of operation can only be changed if the unit has been initialized. Until the unit has been initialized, the following setting applies: Valve closed when actuator spindle extended.

There can also be no change in the direction of operation during an initialization run, whether or not the unit was already initialized before starting the current initialization run.

The direction of operation must not be confused with heating/cooling! Heating in standard mode is carried out with DIP switches 7, 8 and 9 set to "0". Cooling in standard mode is carried out with DIP switches 7, 8 and 9 set to "1". Split-range can be combined with heating in standard mode, but not with cooling. In Modbus mode, split-range can be combined with both heating and cooling.

DIP5:

Saves the current position as switching position "2EZ-1" when switched from 0 to 1. No function is assigned to switching from 1 to 0. Even if DIP 5 is left in position 1 when the 7020A positioner is switched on, the current position will not be saved.

DIP6:

Saves the current position as switching position "2EZ-2" when switched from 0 to 1. No function is assigned to switching from 1 to 0. Even if DIP 6 is left in position 1 when the 7020A positioner is switched on, the current position will not be saved.

DIP7, DIP8 and DIP9:

These three DIP switches work together to define the split range function at analogue input 2 (AI2).

FUNCTION	DIP7	DIP8	DIP9
Linear, 1:1	0	0	0
Split Range: split 50 %, offset 0 %	1	0	0
Split Range: split 50 %, offset 50 %	0	1	0
Split Range: split 33.3 %, offset 0 %	1	1	0
Split Range: split 33.3 %, offset 33.3 %	0	0	1
Split Range: split 33.3 %, offset 66.6 %	1	0	1
11-point characteristic	0	1	1
Inverted: 0 becomes 100 and 100 becomes 0 %	1	1	1

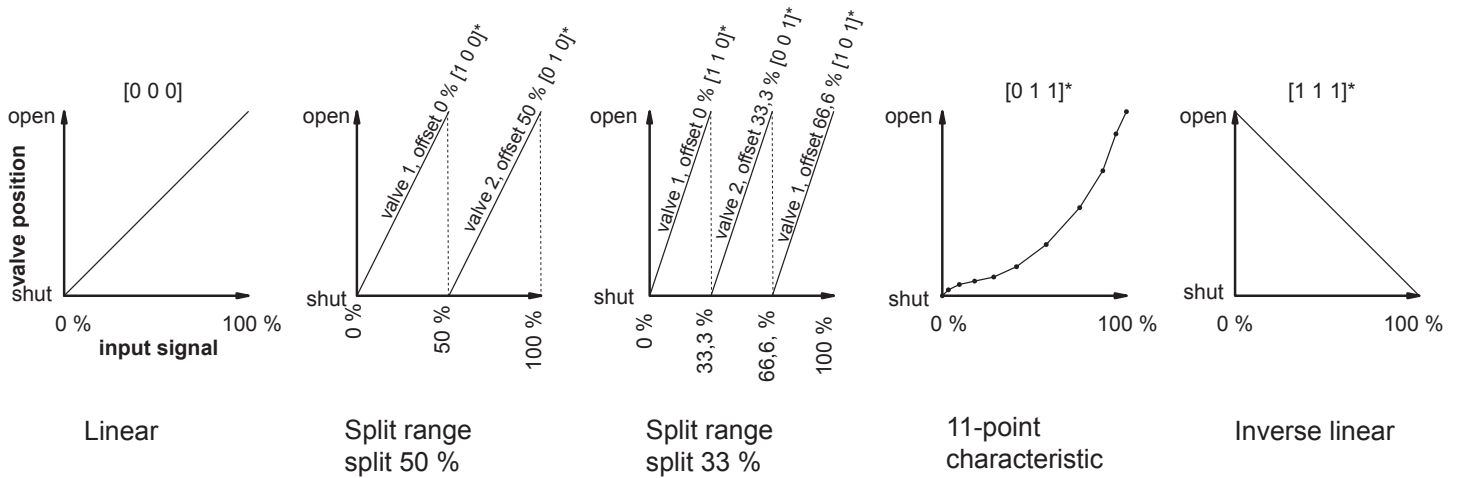

Fig. 11: Graphical illustration of selection of functions by DIP switches 7, 8 & 9

DIP10:

An actuator characteristic can be used indirectly to change a valve characteristic. If, for example, the valve has an equal percentage characteristic, an inverse equal percentage actuator characteristic can be used to generate a resulting linear characteristic, see illustration below.

The actuator characteristic (DIP 10) can also be combined with the characteristics which can be selected using DIPs 7, 8 and 9 (e.g. split range). The microcontroller first processes the characteristic defined by DIPs 7, 8 and 9 and subsequently the characteristic defined by DIP 10.

In Modbus mode, two further actuator characteristics can be selected: equal percentage and quadratic inverse equal percentage.

Desired characteristic	DIP-switch 10	Characteristic of the valve	Characteristic of the actuator	Effective at valve
Equal percentage	 1 0 10			
Quadratic	actuator characteristic only selectable in Modbus mode			
Linear	 1 0 10			
Equal percentage	actuator characteristic only selectable in Modbus mode			
Linear	 1 0 10			

= factory setting

DIP11:

DIP switch 11 defines the mode of operation: 1 = Modbus mode, 0 = standard mode. Standard mode is used to apply predefined normal settings.

DIP12:

Starts an initialization run when switched from 0 to 1. If DIP 12 is left in position 1 when the 7020A positioner is switched on, an initialization run will not be started. As long as DIP 12 is set to 1, errors and alarms occurring during normal positioner operation will not be shown. This enables errors occurring during initialization to be distinguished from errors during normal positioner operation. Switch DIP 12 back to 0 after the initialization run (after having analysed possible error codes) to show any errors occurring in normal positioner operation on the red LED. See also section 8.5.2 "Initialization run".

8.5 Commissioning

8.5.1 Quick start guide

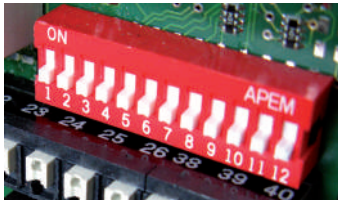

1. Set DIP switches



2. Connect to supply

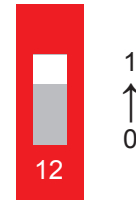

3. Start initialization run

8.5.2 Initialization run

If the unit is not initialized, the green LED flashes. The red LED is lit when the position of the potentiometer is not ideal for an initialization run. (See section 8.5.3 for meaning of LED signals.) An initialization run can still be carried out, but it will take approx. 1x valve travel time longer. During a successful initialization run, the valve is moved to both of its end positions. The potentiometer and the position of the valve are synchronized and values for valve travel time and switching hysteresis are determined.

Switch DIP switch 12 from 0 to 1 to start an initialization run. The red LED is lit during initialization.

When initialization has been successfully completed, only the green LED is lit. For error signals see table in section "Errors after an initialization run", page 27

As long as DIP switch 12 is set to 1, errors and alarms occurring during normal positioner operation will not be shown. This enables errors occurring during initialization to be distinguished from errors during normal positioner operation.

Switch DIP 12 back to 0 after the initialization run to show any errors occurring in normal positioner operation on the red LED.

(After the first initialization run (unit not previously initialized), the unit moves to the 50% position upon completion of initialization. As soon as DIP 12 is set to 0, the baelz 7020A will follow the set value signal at analogue input 2.)

8.5.3 Meaning of LED signals

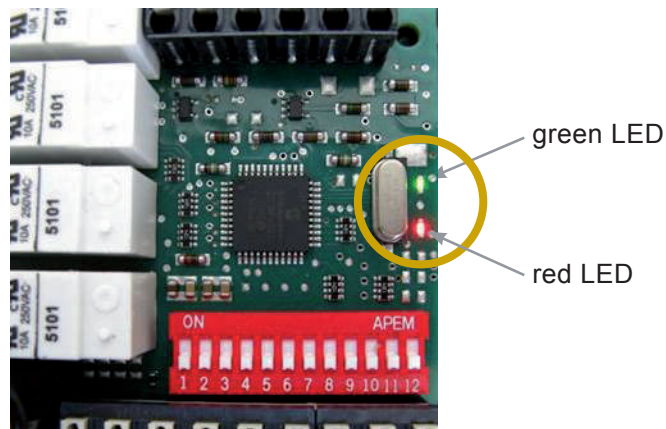

	LED signal	LED signal	Meaning
1	● ●	green off red off	Unit is switched off.
2	● ●	green on red on	Initialization run in progress.
3	★ ●	green flashing red off	Unit is not initialized. Potentiometer in ideal position for initialization run (between 7.5 and 17.5%).
4	★ ●	green flashing red on	Unit is not initialized. Potentiometer not in ideal position for initialization run. Initialization still possible. (If the red LED is flickering, the position of the potentiometer is at the edge of the optimal range and therefore OK.)
5	★ ★	green and red flashing	Error during initialization. Unit is not initialized. The flashing red LED shows the number of the error code: 3 flashes, interval, 3 flashes, interval → error code 3. See also section 8.6.1.
6	● ●	green on red off	Unit is initialized. No errors.
7	● ●	green on red on	Immediately after the unit is switched on, both LEDs are lit for 2 seconds to show that they are in working order.
8	● ★	green on red flashing	Unit is initialized. DIP 12 set to 1 → error after initialization run, see section 8.6.1 DIP 12 set to 0 → error or alarm during normal positioner operation, see section 8.5.2.

8.6 Errors

8.6.1 Errors after an initialization run

Following a successful initialization run, only the green LED is lit.

If the red LED is flashing, this indicates an error following an unsuccessful initialization run.

The first error to occur during initialization is shown. If the green LED is lit, the unit had already been initialized before the current initialization run. If the green LED is flashing, the unit had not been successfully initialized previously.

The red LED shows errors occurring during initialization as follows:

Error code 1: * interval * interval * etc.

Error code 2: ** interval ** interval ** etc.

etc. up to ...

Error code 8: **** interval **** interval **** etc..

Error code	Error	Corrective action
1 → 1 x *	Invalid status of initialization run. Possible cause: EMI (electromagnetic interference).	Remove source of interference.
2 → 2 x **	Sensor malfunction at analogue input AI1: No signal from potentiometer.	Check connection terminals 91, 92, 93 (see wiring diagram, Fig. 9, page 21). Replace potentiometer if necessary.
3 → 3 x ***	Potentiometer value at AI1 too small. Possible cause: EMI.	Remove source of interference. Replace potentiometer if necessary.
4 → 4 x ****	Potentiometer value at AI1 too large. Possible cause: EMI.	Remove source of interference. Replace potentiometer if necessary.
5 → 5 x *****	Wrong direction of travel	Check motor (97, 98, 99) and potentiometer (91, 92, 93) connections (see wiring diagram, Fig. 9, page 21). Remove source of interference.
6 → 6 x *****	Obstruction: potentiometer or motor not moving.	Check connections, set N↔S switch to "N", remove any obstructions.
7 → 7 x *****	Stroke too long.	Fit actuator to a valve with nominal stroke length < 22 mm.
8 → 8 x *****	Stroke too short.	Fit actuator to a valve with nominal stroke length > 8,7 mm, remove any obstructions.

Following an initialization run, the red LED shows only initialization errors as long as DIP switch 12 is set to 1. This enables a clear differentiation between errors occurring during initialization and those occurring during normal positioner operation. Setting DIP switch 12 from 1 back to 0 permits the red LED to show any normal operational errors instead of initialization errors which may have occurred.

8.6.2 Errors during normal positioner operation

The green LED is lit during normal positioner operation.

A flashing red LED shows an error during normal positioner operation. For this, DIP switch 12 must be set to 0.

The red LED indicates errors during normal positioner operation as follows:

( = long flash,  = short flash)

Error code 1:           interval          interval etc.

Error code 2:           interval          interval etc.

etc. up to ...

Error code 6:           interval          interval etc.

Multiple error codes can be displayed simultaneously:

Error codes 3 & 5:           interval      interval

The red LED flashes 10 times between intervals (1.6 s), as a maximum of 10 error codes can be allocated.

The error codes 7 to 10 are not allocated and are reserved for additional alarms.

Error code	Error	Corrective action
1	Sensor malfunction at analogue input AI1: No signal from potentiometer.	Check connection terminals 91, 92, 93 See wiring diagram, Fig. 9, page 21.
2	Sensor malfunction at analogue input AI2: No setpoint signal.	Check connection terminals U, 0, I See wiring diagram, Fig. 9, page 21.
3	Alarm 1: additional switching position (2EZ-1) or other threshold value reached.	Informational alarm: 2EZ-1 is set using DIP 5.
4	Alarm 2: additional switching position (2EZ-2) or other threshold value reached.	Informational alarm: 2EZ-2 is set using DIP 6.
5	Alarm 3: control deviation too large.	Deactivate antifreeze / excessive temp. Re-initialize Baelz 7020A.
6	Alarm 4: potentiometer end stops too imprecise or obstruction.	Deactivate antifreeze / excessive temp. Re-initialize Baelz 7020A.
7-10	Reserved for as yet undefined alarms 5-8	No error possible.

8.7 Technical Specifications

Table 3. Technical Specifications, baelz 7020A	
Supply voltage	230 VAC -15 % / +10 %, 50 / 60 Hz, option: 115 VAC 50 / 60 Hz, 24 VAC 50 / 60 Hz
Fuse	internal 1.6 A/T (slow-blow)
Power consumption	approx. 5 VA
IP rating	IP 42
Ambient temperature	0 to 50 °C
Transport / storage temp.	- 25 to +65 °C
Ambient humidity	5 to 90 % relative humidity. (non-condensing)
Dimensions WxHxD	approx. 105 x 82 x 32 mm
DI supply voltage	24 V DC, I _{max} = 5 mA
Digital input	1 configurable using software, I _{max} 5mA, low=0...5VDC, high=9...38VDC, R _e =5.5kΩ
Digital outputs	2 potential free auxiliary chageover switches, configurable, max. 250 VAC, 4A min. contact load: 10 V / 100 mA
2 output signals	Output 1: 0/2...10 V / min. ohmic resistance 5kΩ Output 2: 0/4...20 mA / max. ohmic resistance 300Ω Factory setting: 0...10 V and 0...20 mA
Input signal	0/2...10V / R _e 63kΩ, 0/4...20mA / R _e 200Ω, measurement accuracy 0.1%
Connection	PUSH IN spring terminals, stripping length 8 mm
Wiring	Wire size AWG: min. AWG 24; max. AWG 16 solid wire / stranded wire: min. 0.2 mm ² ; max. 1.5 mm ² with wire ferrule according to DIN 46 228/1: min. 0.25 mm ² ; max. 1.5 mm ² with insulated wire ferrule DIN 46 228/4: min. 0.25 mm ² ; max. 0.75 mm ²
Operation	12 DIP switches / optional: advanced operation using RS485 and software
Interface	RS485 Modbus RTU, Baud rate 2400...19200, 1 start, 8 pieces of data, 1 stop-bit, no parity
Memory	non-volatile semiconductor
Weight	approx. 0.2 kg

8.8 Accessories and options

- Free parameterisation software (Modbus RTU) - Interface RS 485 required!
- For laptops with USB we recommend our interface convertor (Order No. 5280-051).

9. HEATING - RETROFITTING THE HEATING ELEMENT

Preparatory measures before fitting:

1. Disconnect actuator from power supply
 2. Remove the cap nut from the actuator cover
 3. Pull and gently turn cover to remove
- Screw the temperature sensor firmly into the hole by the load-dependent limit switches. Fix the heating element in its place on the cover using the two screws provided.

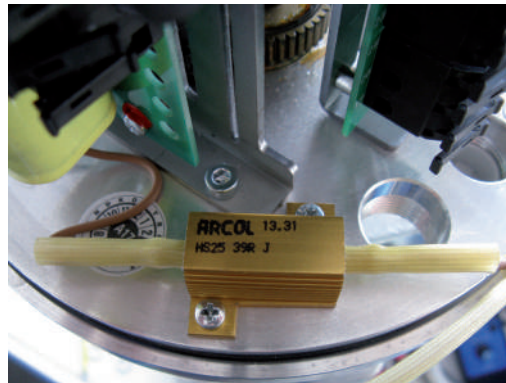
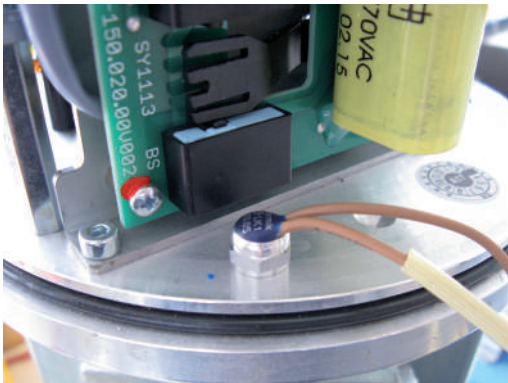

- Remove the screw from the limit switch board and replace it together with the terminal block.

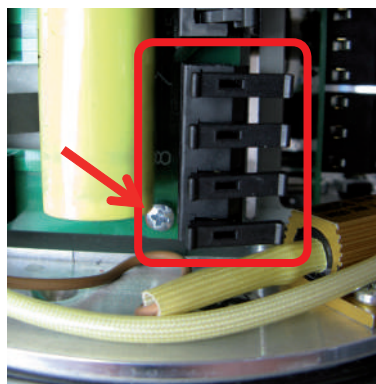
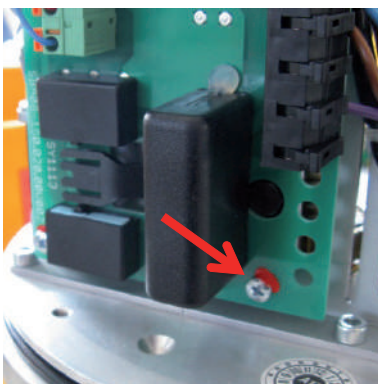

- Connect both wire ends to terminals (7) and (8). Terminals 7 and 8 are then connected to the electrical supply. Fix wiring with cable ties.

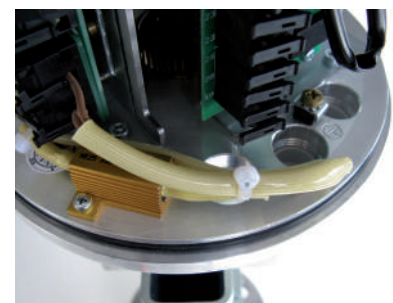
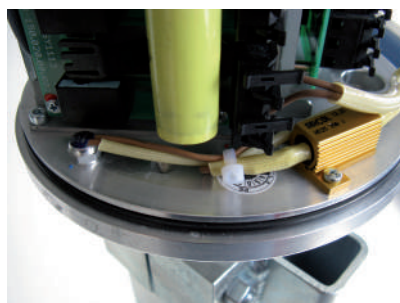
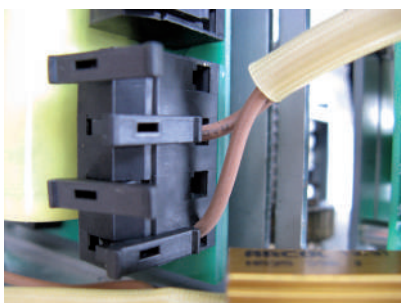

10. SPARE PARTS

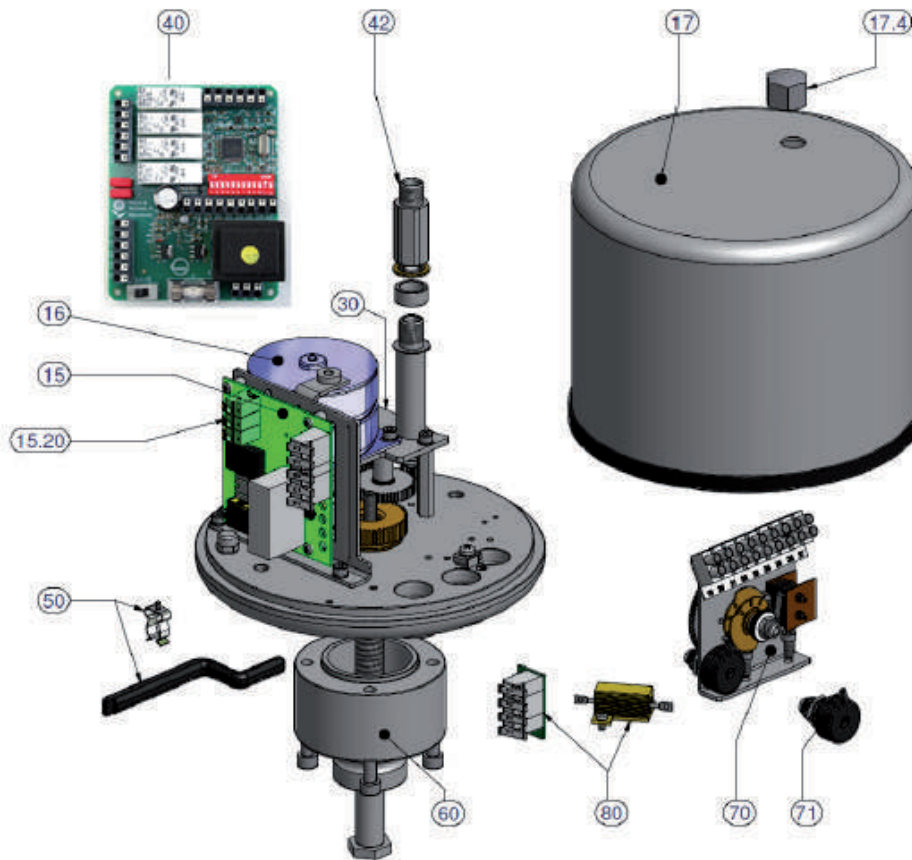

Part no.	Description	Remarks
15	Mounting plate (complete)	
15.20	Circuit board, including motor capacitor (complete)	
16	Motor (complete)	
17	Cover (complete)	(F1653882 and above: new version)
17.4	Cap nut	
30	Mounting plate	
40	Digital positioner 7020A	
41	Fitting material for digital positioner 7020A	
42	Extension	
50	Crank handle (complete)	
60	Flange, complete with connecting rod	
70	Potentiometer assembly including 2 limit switches (complete)	(F1653882 and above: new version)
71	Potentiometer (complete)	(F1653882 and above: new version)
80	Heating element (complete)	

When ordering accessories or spare parts, please note the specifications on the actuator nameplate for essential information regarding actuator and power supply criteria.



Risk of damage to actuator due to incorrect or defective spare parts!

All spare parts must comply with the technical requirements as stated by the manufacturer.

- Use only original spare parts!

11. DECOMMISSIONING AND DISPOSAL

Dispose of the digital positioner in accordance with the relevant, country-specific regulations and laws..

12. TROUBLESHOOTING

If the actuator does not work properly, proceed as follows to correct the problem:

1. Check that the actuator is correctly installed.
2. Check the actuator settings and the specifications on the nameplate.
3. Correct the problems as specified in the checklist (page 33).
4. If the problem cannot be corrected, contact the Baelz service department.
5. If, despite consultation, the issue still cannot be resolved, the device can be returned to Baelz for repair / replacement by arrangement with the service department.

Please give the following information when contacting the manufacturer or sending the device in for repair:

- F number (order-related serial number)
- Type name
- Supply voltage and frequency
- Extras fitted
- Error report

12.1 Checklist for operational malfunctions

Malfunction	Cause	Action required
Actuator not working	Power failure	Determine the cause and correct the problem.
	Defective fuse (in control cabinet)	Determine the cause and correct the problem, replace the fuse.
	Linear actuator incorrectly connected	Re-connect as specified on circuit diagram (inside cover).
	Short circuit caused by humidity	Determine the cause, dry the linear actuator; if necessary, replace cover seal and screws and/or fit protective cover.
	Short circuit caused by incorrect connection	Connect correctly.
	Motor winding damage caused, for example, by high voltage or defective electronics	Determine cause, measure current data, compare with nameplate and specifications, dismantle linear actuator and return for repair.
	Voltage drop due to connecting cables being too long and / or having insufficient cross-section	Measure current data with linear actuator, recalculate connecting cables and replace as necessary.
Actuator running erratically, constantly opening and closing	Power fluctuations exceed permissible tolerance	Improve power supply conditions.
	Loose contact in supply line	Check and tighten connections (terminal blocks).
Actuator stops intermittently	Valve jamming	Enable smooth valve movement.
Actuator does not move to end position. Valve fails to open / close	System pressure too high	Adjust system pressure.
	Poor input signal - interfering signals - signal fluctuation	Check input signal at linear actuator, correct the problem causing the malfunction.
Linear actuator fails to move or does not move correctly to the position defined by the input signal.	Circuit board defective	Replace circuit board, if necessary dismantle actuator and return for repair.

13. DIMENSIONAL DRAWINGS

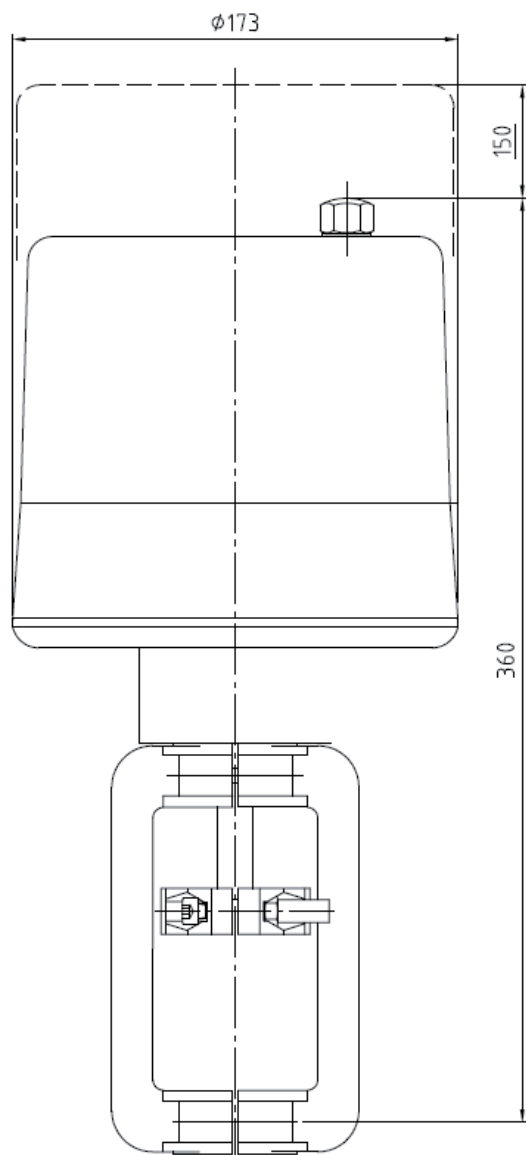

**Fig. 12: Dimensional drawing
baelz E45 with S21 yoke
and spindle $\phi 10$ mm**

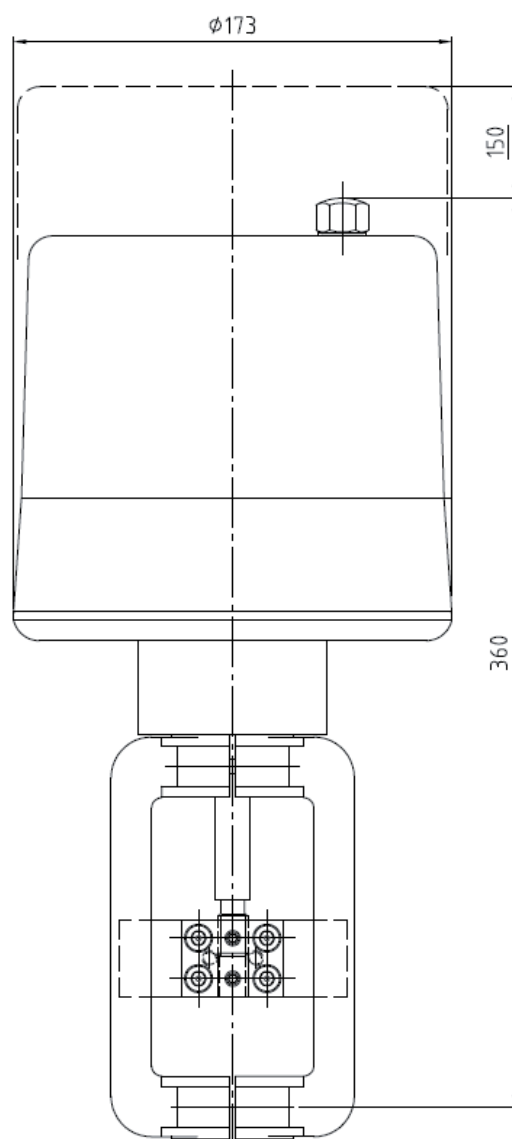

**Fig. 13: Dimensional drawing
baelz E45 with S21L yoke
and spindle $\phi 16$ mm**

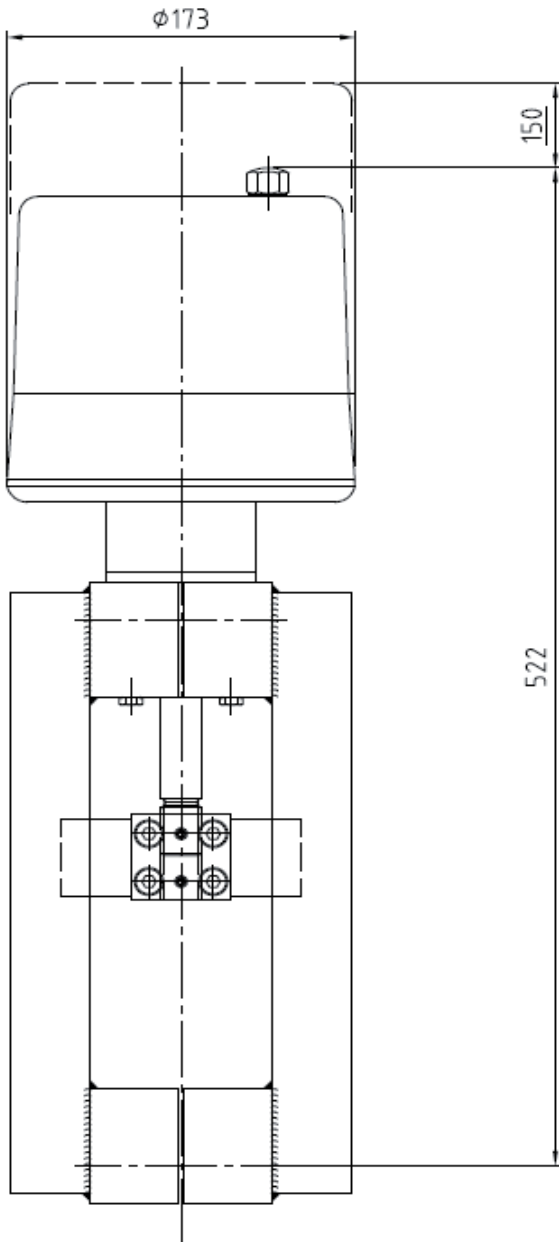

**Fig. 14: Dimensional drawing
baelz E45 with S41 yoke
and spindle $\phi 16$ mm**

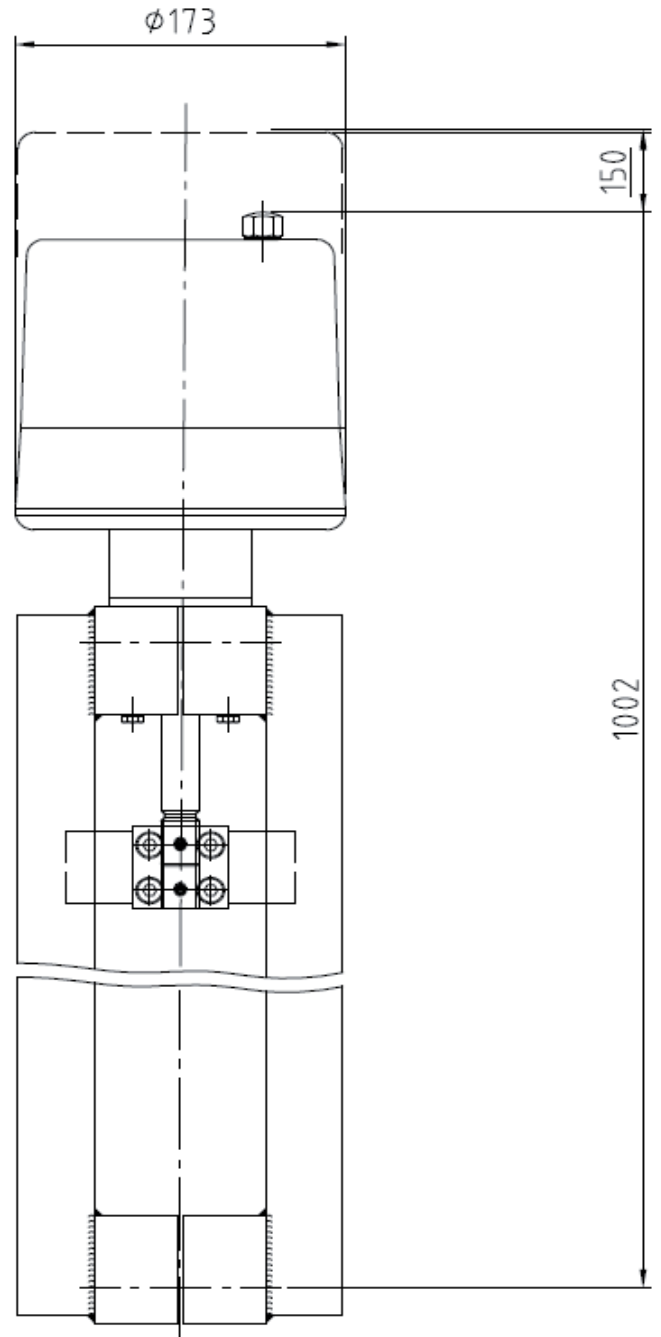

**Fig. 15: Dimensional drawing
baelz E45 with S41C yoke
and spindle $\phi 16$ mm**

BA_373-E45_05_DEF_MJ_2119

