

Series 2600

Pressure Relief Valves





Table of Contents

Introduction	1
The Farris Advantage.....	2
2600 Series Design	3
2600 Series Construction	4
2600 Series Metallurgy	5
2600 Series Operation.....	6-7
General Technical Information.....	8
Definitions	9

Scope

Type Numbering System.....	10-11
Ordering Information, Replacements.....	10
Standard Bills of Material.....	12-13
Series 2600L Certified Design	14
Series 2600S Exposed Spring.....	15
2600/2600L Balanced Piston Design.....	16
Heat Transfer Fluid Service/Low Temperature	17
Corrosive and Low Temperature Materials	18-20
Sour Gas (H ₂ S) Materials.....	21
O-Ring Seat Pressure Seal.....	22-23
Orifice Selection Tables and Charts, U.S. Units	24-38
Orifice Selection Tables and Charts, Metric Units	43-56
Super Capacity Valve Scope.....	61
Super Capacity Bills of Materials	62-63
Valve Pressure Limits (Special Materials).....	79-83

Capacity Tables

Air 10% Overpressure, U.S. Units.....	39
Steam 10% Overpressure, U.S. Units	40
Water 10% Overpressure Code 2600L, U.S. Units	41
Water 25% Overpressure, Non Code, U.S. Units	42
Air 10% Overpressure, Metric Units	57
Steam 10% Overpressure, Metric Units	58
Water 10% Overpressure, Code 2600L, Metric Units	59
Water 25% Overpressure, Non Code, Metric Units	60
Super Capacity 2600 Series Overpressure, U.S. Units	64-65
Super Capacity 2600 Series Overpressure, Metric Units	66-67

Accessories

Cap and Lever Materials.....	68
Test Gag Installations.....	69
Remoter, Bugproof Vent and Valve Position Indicators	70
Steam Jacketing Methods	71

Dimensions and Weights

Valve Dimensions and Weights	72-75
ANSI Flange Connection Types.....	76
ANSI Flange Dimensions.....	77
DIN Flange Dimensions.....	78

Sizing

Sizing Equations and Nomenclature.....	84
Conventional Valves.....	84
BalanSeal Valves	85
Fluid Data.....	86
Sizing Factors for Vapors & Gases.....	87
Sizing Factors for Steam.....	88
Sizing Factors for Liquids.....	89-91
Conversion Factors	92

Introduction

This catalog covers Series 2600, 2600S and 2600L pressure relief valves including the latest information available to assist you in the sizing and selection of the proper valves for your application.

Farris pressure relief valves have over a half century of proven performance providing automatic and positive protection against overpressure in thousands of industrial plants and facilities worldwide. Our earned reputation as “the First Line of Safety” is the result of countless Farris innovations combined with progressive engineering, sound design and high quality production.

Our headquarters and manufacturing facility located in Brecksville, Ohio, oversees the production of these superior valves at plants in the United States, Canada, the United Kingdom, and China. The Brecksville facility is also responsible for research and development, engineering, manufacturing technology, and sales and marketing. We offer the services of our engineering sales representatives throughout the world as well as our Farris Authorized Service Teams (FAST Centers) and headquarters staff to extend you every possible customer service.

Warranty

All products manufactured by Farris Engineering are warranted free of defects in material and workmanship when used within the range recommended for a period of one year after installation or eighteen months from delivery. When authorized, any defective product may be returned to the factory and if found defective will be repaired or replaced free of charge, solely at the discretion of Farris Engineering, ex-works our factory. No charge for labor or other expense incurred will be allowed, as the liability of Farris Engineering is measured by the refund price of the defective product only. All warranties are based on the product being used within the range recommended and does not cover damages or defects due to normal wear and tear, misuse, alteration or neglect. The purchaser shall determine the suitability of the product for use and assumes all risks and liabilities in connection therewith.

This warranty does not cover the performance of valves tested at site on test equipment that is not to the same technical standard as that used by the manufacturer.



The Farris Advantage

Farris pressure relief valves are designed to automatically protect your equipment against excessive overpressure. Every care is taken in the development, design and production of these valves to ensure complete dependability in performance. Our constant objective is to provide a superior valve that will assure ultimate protection at the lowest cost, both initially and throughout its service life.

What is the Farris Advantage?

- Easy sizing and selection of valves using Farris catalogs and/or SizeMaster™ Sizing and Selection software.
- A method of specification and ordering that is simple, accurate and complete.
- Accurate and timely shipments in accordance with our computerized inventories.
- Factory-trained engineering/sales staff to assist you in solving your pressure relief valve problems.
- Streamlined design to allow you maximum flexibility in the use and repair of your Farris pressure relief valves.
- Assurance of the utmost safety of your equipment when protected by a Farris valve.
- Maximum seat tightness in accordance with stringent inspection and testing.
- Complete repair and maintenance information that affords you repairs in your own maintenance shop.
- Maximum interchangeability of parts.
- Continuous availability of replacement parts at our plants and authorized service centers for immediate shipment to meet your emergency requirements.
- Long service life of a soundly-designed pressure relief valve made from materials suited to your service.
- Twenty-four hour/seven-day customer support is achieved via our FAST Centers and our Web-based CW Commerce Program accessible to all Farris Representatives.

2600 Series Design

Valve Selection

This catalog simplifies the sizing and selection of Series 2600 process pressure relief valves. The pressure relief valves are presented here in an easy-to-understand format. Unless otherwise stated, references made to the Code refer specifically to ASME Section VIII, Division 1.

Certified Capacity Code Compliance

The Series 2600 pressure relief valves have been carefully constructed and tested in accordance with the requirements of the ASME Pressure Vessel Code, Section VIII. Their capacity rating for the applicable fluids is certified by the National Board of Boiler and Pressure Vessel Inspectors.

Range of Service Application

Series 2600 pressure relief valves are designed to function equally well on air, gases and steam or in liquid service. For specific Code applications in liquid service, Farris 2600L relief valves offer superior performance. This catalog covers orifice ranges "D" through "Z".

Nozzle Design

The Farris full nozzle pressure relief valve design (Fig 1) incorporates a nozzle shape to provide:

1. A high stable flow coefficient.
2. Greater strength to resist possible discharge piping strains.
3. Wrenching provisions on raised face nozzles where they will not interfere with the flow path.

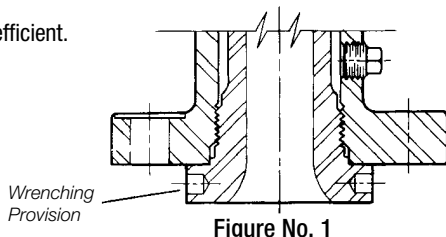

The superior design allows easy maintenance by simplifying nozzle removal and assembly.

Balanced Bellows Design

Both the Farris BalanSeal balanced bellows (Fig 2A) and the BalanSeal/Piston pressure relief valve provide consistent capacity, set pressure and blow down at elevated backpressure encountered when valves discharge into headers or where other devices produce variable backpressure in the relief manifold system. Nozzle can be removed from Body with the Blowdown Ring attached.

The Farris BalanSeal design permits simple conversion of conventional construction valves to BalanSeal balanced bellows construction by adding a bellows and bellows gasket for orifice sizes "F" through "T".

The "D" and "E" orifices are available with balanced bellows through the class 600 inlet, with higher class valves available in an unbalanced bellows design (Fig 2B). The unbalanced bellows is used for corrosion isolation applications, and can also be used where constant backpressure is encountered. Spring setting compensation is made for constant backpressure applications.

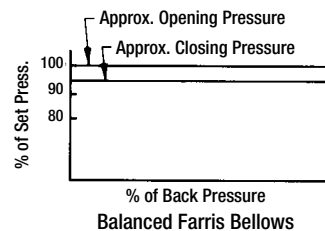
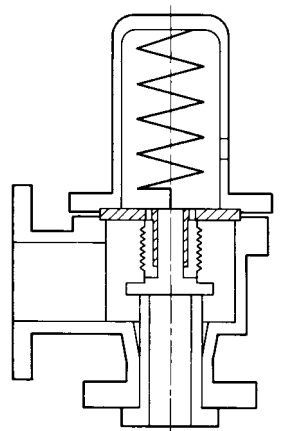

Figure No. 2A

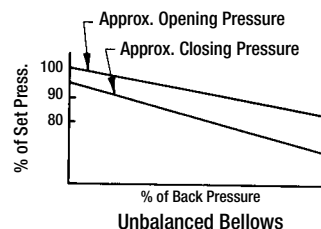
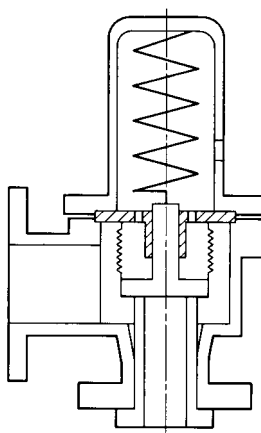

Figure No. 2B

2600 Series Construction

Resistance to Discharge Piping Strains

For most pressure relief valves, and particularly for those from which the discharge must be piped away to a remote location, it is almost impossible to keep piping strains away from the valve. The superior Farris pressure relief valve design incorporates several features which allow this valve to take a maximum amount of piping strain without hampering the functional characteristics of the valve or contributing to serious leakage.

1. The threaded connection between the valve nozzle and the valve inlet flange is located low in the flange so that any distortion which may take place at the inlet neck of the body is not transmitted to the valve nozzle. This eliminates the effect of the distortion on the nozzle seating surface and the subsequent serious leakage through the valve (Fig 3).
2. The accurate guiding in the Farris design, using the double universal ball joint construction above and below the sleeve guide, will allow the disc seat to align itself positively with the nozzle seat in cases where the discharge piping strains cannot be avoided and have forced the upper portion of the valve out of exact alignment (Fig 4 & 5).
3. The superior strength built into the body of the Farris pressure relief valve to resist these discharge piping strains materially reduces the deflection and distortion in the valve and reduces the leakage encountered, when at times discharge piping strains become excessive.

In spite of these features, however, it is advisable to minimize the discharge piping strain on any pressure relief valve. It is our recommendation that piping engineers eliminate these discharge piping strains as much as possible under all operating conditions. Additional information on allowable external loads is provided in the Farris Technical Recommendations publication.

Isolation of Bonnet Spring Chamber

The Farris pressure relief valve huddling chamber is engineered to extract the flow forces required to overcome the force of the spring as well as the forces resulting from the body and bonnet pressure when the valve is open. In other designs, the use of eductor tubes, venting the guide directly into the valve body, or other techniques are used in an attempt to keep the huddling chamber or body pressure away from the topside of the disc to obtain full lift and capacity. These designs may have undesirable effects on valve performance, life and maintenance. Special attention should be given in the following cases:

1. **High Temperature.** In Farris pressure relief valves on high temperature service, there is no induced or forced flow of the hot lading fluid into the bonnet spring chamber, so relaxation of the spring due to high temperature does not occur as rapidly as it does in other valve designs. As a result, blow down in the Farris valve is stabilized for longer flowing periods than in competitive designs.

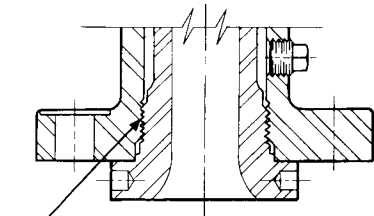

Threaded connection of nozzle located in inlet flange to avoid distortion on the nozzle seating surface.

Figure No. 3

If connected to a closed system, specific care should be taken to keep piping strains away from the pressure relief valve under all conditions of process operation.

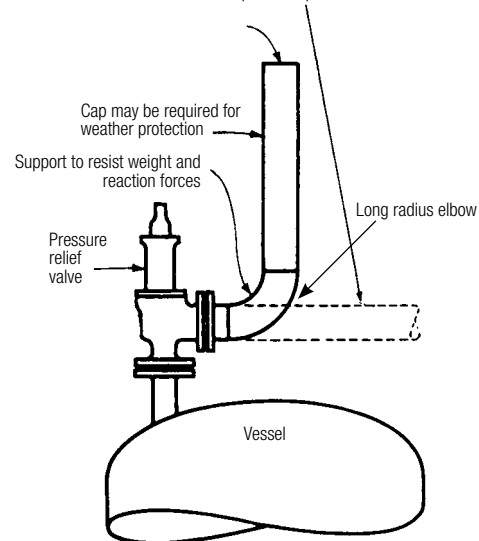

Figure No. 4

2. **Corrosive Service.** In Farris pressure relief valves on corrosive service, there is no induced or forced flow of the corrosive lading fluid past the guiding surfaces during valve operation. This reduces the corrosive effect of the lading fluid on the guiding surfaces and valve spring, so lowering the frequency of galling and spring failure with the accompanying reduction of maintenance costs and unscheduled down time.
3. **Dirty Service.** Where small foreign particles can be carried in the gas or vapor stream, there is no induced or forced flow in the Farris design carrying these small particles between the guiding surfaces. Galling of the guide surfaces, which frequently causes the valve to “hang” or “freeze” in either an open or closed position, is eliminated.

The Farris design avoids all these difficulties by discharging directly from the huddling chamber into the valve body without inducing flow past the guiding surfaces into the spring chamber or forcing flow past the guiding surfaces because of the large pressure drop between the huddling chamber and the valve body.

2600 Series Metallurgy

Integral Sleeve Guide

The Farris pressure relief valve design incorporates an integral sleeve guide (Fig 5), assuring continual positive alignment after the part has been manufactured, and including the same high corrosion resistant properties in the guide flange that are present in the sleeve portion of the guide. The sleeve guide is extended above the top of the guide flange, minimizing the possibility of corrosive or other foreign particles washing onto the guiding surfaces when the valve is relieving or when it is “breathing” as a result of atmospheric temperature changes. Openings are provided in the guide flange to allow these solid particles to leave the bonnet, preventing them from passing between the guiding surfaces and causing galling.

Tightness

In a spring loaded pressure relief valve, the force exerted by the system pressure under the valve disc approaches the opposing spring force on top of the valve disc as the system operating pressure nears the set pressure of the valve. Since the operating pressure of the system is often 90% of the valve set pressure, the differential force holding the seats together is quite small.

There are several factors which affect the tightness of the spring loaded pressure relief valve, including alignment, disc strength, thermal distortion, and preparation of seating surfaces. The Farris valve is engineered for exceptional tightness because of positive alignment, a high strength disc design, the elimination of thermal distortion and optimum seating surface finish.

Positive Alignment. Using the double universal joint, 2-1/2 to 1 guiding ratio, and self-aligning disc, positive alignment of internal parts is achieved. Misalignment is avoided, improving tightness and eliminating other undesirable effects such as long blow down.

High Strength Disc Design. In the Farris valve, the thickness of the self-aligning disc (Fig 6) is no greater than necessary; however, the same thickness is maintained for all catalog materials. For purposes of strength, the disc is strong enough in bending moment for all materials shown in the catalog. Valves constructed with hardened discs are exceptional in withstanding the effects of impact, an advantage where installation or process conditions may cause chatter.

Elimination of Thermal Distortion. In a pressure relief valve, especially on high or low temperature service, a single large disc, with its top surface exposed to atmospheric temperature when the valve is closed, has a temperature gradient between the surface contacted by the lading fluid and the surface contacted by the ambient temperature in the valve body or bonnet. This temperature gradient induces thermal stresses in a heavy disc that can cause deformation of the seating surfaces and consequent leakage of the valve.

The Farris self-aligning disc is essentially encased in a disc holder with contact at only one central point, so that the conduction or convection of heat around the disc is quite low. As a result, the thermal stresses at the seating surface practically disappear. This gives further assurance of tightness over the range of temperatures used in various operations.

Optimum Seating Surface Finish. Seat surfaces are machine lapped and polished to produce flatness (as measured with optical flats) that deviates less than eleven millionths of an inch from a true plane, with a surface finish of five micro inches or less. Regardless of the seating surfaces, maximum tightness will not be achieved unless positive alignment and elimination of thermal distortion are integral design features of the valve.

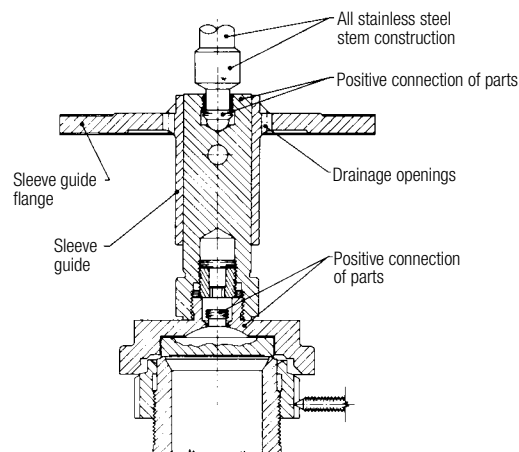

**Integral Sleeve Guide
Figure No. 5**

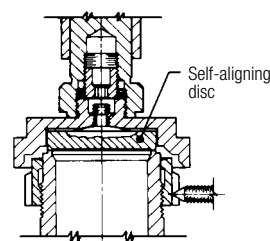

**High Strength Disc
Figure No. 6**

2600 Series Operation

All Stainless Steel Stem Construction

The Farris pressure relief valve design features an all stainless steel stem. This construction cost-effectively eliminates dangerous sticking due to galvanic corrosion at the upper guiding point in the spring adjusting screw. The careful design of this upper bearing also ensures proper alignment and optimum freedom from galling and erratic popping.

Positive Connection of Parts

The Farris design incorporates a positive connection between the valve stem and the stem retainer as well as between the disc and disc holder (Fig 7). These connections are made with a male threaded head which threads into a portion of a female socket through which it drops free into an undercut chamber to make bearing contact on a spherical surface. This allows complete freedom of action for alignment purposes while retaining the positive connection of the threads. It also eliminates the need to use snap ring connections which, in some cases, are not sufficiently positive during valve operations and may be inadvertently left out during maintenance.

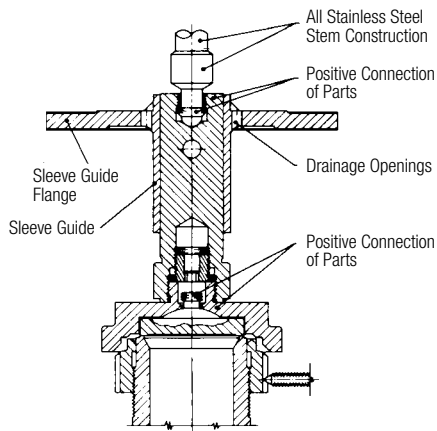

Positive Connection of Parts
Figure No. 7

The Farris two-piece design of disc holder and stem retainer features a positive locking device called the disc holder lock screw. Any attempt to disassemble these parts causes the lock screw to lock tighter, unless first disengaged. The lock screw provides a positive lock between these two parts that makes them equivalent to a single part but without the associated disadvantages. The two-piece assembly allows conversion to bellows construction at a minimal investment. The two-piece design also allows the stem retainer to be constructed of less corrosion-resistant material than the disc holder, when a bellows is installed to isolate the moving parts. When maintenance requires parts replacement, the entire assembly will not need replacement if only one piece is damaged.

Convertibility of Design

The Farris pressure relief valve is available as a conventional valve and as a BalanSeal (balanced bellows) valve. The conversion of this valve from conventional to BalanSeal, or vice versa, requires only the addition or removal of the balanced bellows and bellows gasket in the valve, and the coincidental removal or replacement of a pipe plug in the valve bonnet vent. No other parts are required and all other parts are completely interchangeable. This unique feature is offered in orifices "F" through "T".

In addition, the bonnet of the valve is constructed so that all valves can be equipped with a plain screwed cap, bolted cap, an open lever or packed lifting lever without changing any other valve parts or fully disassembling the valve.

Body and Bonnet of Equal Materials

Although the Farris pressure relief valve does not induce circulation of the lading fluid through the bonnet, the bonnet and the valve body are made of the same high quality steel. It is important that both the body and bonnet be made of materials suitable for the service in which the valve will be used, especially in the case of high temperature services.

2600 Series Operation

Steam Jacketing for Better Heat Transfer

In modern process plants, it is necessary to keep some valves and lines warm at all times to avoid solidification of the lading fluid and to guarantee the safety of equipment. Farris offers a steam jacket (Fig 8) to substantially increase the rate of heat transfer into the valve and, at the same time, simplify the problem of removing or dismantling the valve for maintenance. This design offers a separate two-piece jacket that installs on a standard valve body. See details on page 71.

Simple, Accurate Adjustments

The single Blow Down Ring construction of the Farris pressure relief valve allows simple shop or field setting, something not possible with multiple ring valve types.

In most process plants, it is not possible or economical to test the pressure relief valve in place on the process equipment, so the valve is tested while mounted on a maintenance shop test stand where the pressure and volume for testing are often limited. With the Farris design, the single Blow Down Ring is adjusted in the maintenance shop so that the set pressure point can be observed. After the set pressure is established, the Blow Down Ring is adjusted to a lower empirically predetermined or field established position depending on set pressure, size and lading fluid (Figs 9A, 9B). Blow Down Ring settings and test equipment recommendations are detailed in maintenance manuals published by Farris Engineering.

Interchangeability of Parts

In the Farris pressure relief valve design, maximum interchangeability of parts is maintained in order to reduce the number of spare parts needed and keep spare parts inventories to a minimum.

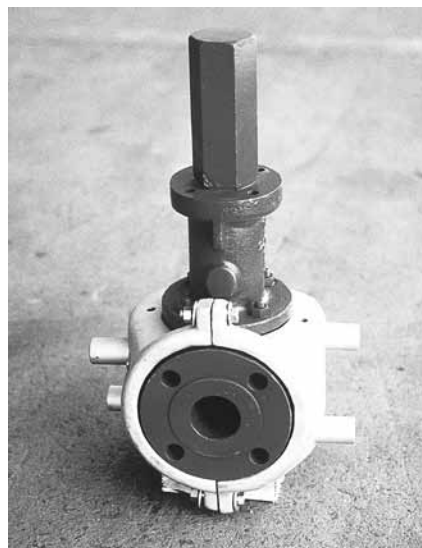

Steam Jacketed Body

Figure No. 8

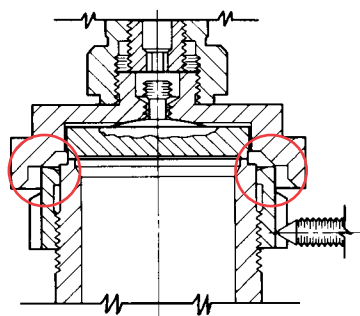

Blow Down Ring Adjustment
For Set Pressure Test

Figure No. 9A

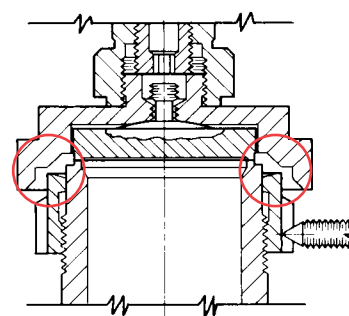

Blow Down Ring Adjustment
For Service Operation – Vapors

Figure No. 9B



General Technical Information

Standard Flanged Connections

1. All steel raised face flanges are supplied with a serrated spiral finish with 45 to 55 grooves per inch and a finish between 125 and 160 AARH.
2. All ring joint flanged facings are supplied for octagonal or oval gaskets.
3. Facings other than raised face or large male can be supplied at additional cost.
4. Flange ratings that conform to ANSI B16.5 are indicated on each Orifice Selection Table. Heavier outlet flanges can be supplied at additional cost. For flange dimensions, see ANSI Dimension Table, page 77.
5. Drilling of all flanges always straddles the valve center line.

Valve Trim

Trim is a term that generally refers to internal parts of a pressure relief valve. Unless noted, valve trim in a Farris pressure relief valve specifically includes the nozzle and disc only. Standard bills of materials for all 2600 Series valves are located on pages 12 and 13. For low temperature and corrosive service materials, see pages 17 through 21. If other than standard trim or metallurgy is required, this must be specified.

Differential Between Operating and Set Pressure

For best performance in process applications, we recommend pressure relief valves be set to open at a minimum of 10% or 25 psig above the operating pressure. A suitable margin above the operating pressure should be provided in order to prevent any unintended operation of the pressure relief valve. Refer to ASME Section VIII Pressure Vessel Code, Appendix M, Paragraph M-10, Pressure Differentials for Pressure Relief Valves as well as to Farris Technical Recommendations for complete information.

In the case of pump and compressor discharge lines, a greater differential is recommended if possible, since pulsations within the system can result in faulty valve operation. Consequently, the pressure relief valve should be set as high above the discharge line pressure as possible.

Set Pressure Compensation for Temperature

An increase in temperature causes a reduction of valve set pressure as a result of the direct effect of temperature on the spring and expansion of body and bonnet which reduces spring loading. Since pressure relief valves are invariably tested at atmospheric temperature, it is customary to adjust the set pressure at ambient conditions to compensate for higher operating temperatures as indicated in the following table.

All Service Fluids

Operating Temperature	% Increase in Set Pressure At Atmospheric Temperature
-450° F to 300° F	None
301° F to 600° F	1%
601° F to 900° F	2%
901° F to 1200° F	3%

Steam service valves are tested on steam by the manufacturer and require no additional temperature compensation. Where the set pressure is above the production steam test facility limits, Section VIII steam valves may be tested on air. When steam valves are tested on air, compensation shown in the All Service Fluids Table should be used.

Low Pressure Settings

Low set pressure limits are indicated in the following table. These limits apply to both metal-to-metal and O-ring seat construction. Low pressure settings may be governed by valve design and performance and/or Code application limits. Pressure vessels having operating pressures not exceeding 15 psig are not considered within the scope of the ASME Code, Section VIII. Accordingly, pressure relief valve requirements for such applications are governed by other Codes and Standards that should be consulted.

The sizing equations for compressible fluids provided herein are valid for sonic flow conditions and should not be used to size pressure relief valves for applications in which subsonic (below 15 psig) flow conditions may exist. Low pressure applications can be reviewed by the Factory and special valves provided to meet those requirements.

Valve Series	Construction	Low Set Pressure Limit (psig)
2600	Conventional	15
2600S		
2600L		
2600	BalanSeal BalanSeal/ Piston	15*
2600S		
2600L		
2600 Bal/Piston		

*Low set pressure limit for "D" and "E" orifice BalanSeal (balanced bellows) valves are 50 psig and 25 psig respectively.

Definitions

Safety Valve – an automatic pressure relieving device actuated by the static pressure upstream of the valve, and characterized by rapid full opening or pop action. Used for steam, gas or vapor service.

Relief Valve – an automatic pressure relieving device actuated by the static pressure upstream of the valve, which opens in proportion to the increase in pressure over the opening pressure.

Safety Relief Valve – an automatic pressure actuated relieving device suitable for use as either a safety or relief valve, depending on the application.

Pressure Relief Valve – a pressure relief device designed to re-close and prevent the further flow of fluid after normal conditions have been restored.

Set Pressure – in pounds per square inch gage, the inlet pressure at which the pressure relief valve is adjusted to open under service conditions. In a safety or safety relief valve in gas, vapor or steam service, the set pressure is the inlet pressure at which the valve pops under service conditions. In a relief or safety relief valve in liquid service, the set pressure is the inlet pressure at which the first steady steam flows from the valve perpendicular to the outlet.

Differential Set Pressure – the pressure differential, in pounds per square inch between the set pressure and the constant superimposed back pressure. It is applicable only when a conventional type safety relief valve is being used in service against a constant superimposed back pressure.

Cold Differential Test Pressure – in pounds per square inch gage is the inlet static pressure at which the pressure relief valve is adjusted to open on the test stand. This pressure includes the corrections for service conditions of back pressure or temperature, or both.

Operating Pressure – the pressure, in pounds per square inch gage to which the vessel is usually subjected in service. A vessel is usually designed for a maximum allowable working pressure, in pounds per square inch gage, which will provide a suitable margin above the operating pressure in order to prevent any undesirable operation of the relief device. It is suggested that this margin be as great as possible consistent with economical vessel and other equipment design, system operation and the performance characteristics of the pressure relieving device.

Maximum Allowable Working Pressure – the maximum gage pressure permissible in the top of a completed vessel in its operating position for a designated temperature. This pressure is based on calculations for each element in a vessel using nominal thicknesses, exclusive of allowances for corrosion and thicknesses required for loadings other than pressure. It is the basis for the pressure setting of the pressure relieving devices protecting the vessel. The design pressure may be used in place of maximum allowable working pressure in cases where calculations are not made to determine the value of the latter.

Overpressure – a pressure increase over the set pressure of a pressure relief valve, usually expressed as a percentage of the set pressure.

Accumulation – the pressure increase over the maximum allowable working pressure of the vessel during discharge through the pressure relief valve, expressed as a percent of that pressure or in pounds per square inch.

Blow down – the difference between actual popping pressure of a pressure relief valve and actual reseating pressure, expressed as a percentage of set pressure or in pressure units.

Lift – the actual travel of the disc away from closed position when a valve is relieving.

Back Pressure – the static pressure existing at the outlet of a pressure relief device due to pressure in the discharge system.

Constant Back Pressure – back pressure that does not change appreciably under any condition of operation whether the pressure relief valve is closed or open.

Variable Back Pressure – refer to the discussion on BalanSeal valves on page 85.

Built-Up Back Pressure – pressure existing at the outlet of a pressure relief device occasioned by the flow through that particular device into a discharge system.

Superimposed Back Pressure – the static pressure existing at the outlet of a pressure relief device at the time the device is required to operate. It is the result of pressure in the discharge system from other sources.



Type Numbering System

Our type numbering system simplifies the selection and specifying of Farris pressure relief valves because the digits that comprise a specific type number have a distinct significance. The digits describe the basic valve series, orifice, seat and internal construction, inlet temperature range, body, bonnet and spring material, inlet flange class and Code liquid design.

Prefix 26		D				A		1			
(if applicable)		Series Number		Orifice Areas		Construction		Temperatures & Materials			
H	26	Orifice Letter	Area, Sq. In.		Area, Sq. mm*		A Conventional construction	Designation	Inlet Temperature Range °F	Material	
			API	Actual	API	Actual				Body & Bonnet	Spring
Designates high pressure versions. Used for "Q", "R", "T", & "U" orifices only.		D	0.110	0.150	71	97	B BalanSeal construction	1	-20 to 800	Carbon Steel	Chrome Alloy
		E	0.196	0.225	126	145	C Conventional with O-ring seat pressure seal				
		F	0.307	0.371	198	239	D BalanSeal with O-ring seat pressure seal				
		G	0.503	0.559	325	361	E BalanSeal with auxiliary balancing piston				
		H	0.785	0.873	506	563	F BalanSeal with auxiliary balancing piston and O-ring seat pressure seal				
		J	1.287	1.430	830	923	T Teflon seat, conventional				
		K	1.838	2.042	1186	1317	U Teflon seat, BalanSeal				
		L	2.853	3.170	1841	2045					
		M	3.60	4.000	2323	2581					
		N	4.34	4.822	2800	3111					
		P	6.38	7.087	4116	4572					
		Q	11.05	12.27	7129	7916					
		R	16.0	17.78	10323	11471					
		T	26.0	28.94	16774	18671					
		U	—	31.5	—	203.2					
		W	—	63.62	—	410.2					
		W2	—	104.0	—	670.8					
		X	—	113.1	—	729.5					
		Y	—	143.1	—	923.0					
		Z	—	176.7	—	1139.7					
Note: The "U" through "Z" orifices are not API Standard Sizes. * "U" through "Z" metric areas in square centimeters.											

Ordering Information

To process your order properly and promptly, please specify the following:

- Quantity*
- Inlet and outlet size
- Farris type number*
- Inlet and outlet flange class and facing
- Materials of construction, if other than standard
- O-ring seat pressure seal material, if required
- Set pressure*
- Maximum inlet temperature*
- Allowable overpressure*
- Fluid and fluid state*
- Back pressure, superimposed constant and/or variable and built-up*
- Required capacity*
- Accessories
 - Bolted cap, open or packed lever
 - Test gag
 - Remoter

14. Code requirements, if any

15. Physical properties of fluid (molecular weight, specific gravity, etc.)

*As a customer service, we verify your selection and sizing. If you want this service, you must include this information.

Parts Replacement

Valves – If an exact replacement valve is required, then the valve type, size and serial number must be specified to ensure proper dimensions and material being supplied. If a specific valve is obsolete, a recommendation of the current equivalent will be made if possible.

Spare Parts – When ordering parts, use part names as listed in the bills of materials. Specify valve type, size and serial number. If the serial number is not available, the original Farris factory order number will help us supply the proper part and material.

Springs – Order as an assembly to include spring with upper and lower spring buttons. Specify valve type, size, serial number, set pressure and backpressure, if any.

Note: If valve modification or set pressure changes are required, consideration must be given to correct the nameplate and other data.

2		L -	1	2	0	/S4
Inlet Class		Special Construction (if applicable)	Inlet Facing	Cap Construction	Test Gag	Special Material
Designation	ANSI Nominal Inlet Flange Class	A Expanded API sizes: air, steam and gas service* B Expanded API sizes: ASME liquid valve* C Expanded API sizes: ASME Code Section VIII exposed spring design* D Valve suitable for heat transfer service-vapor E Valve suitable for heat transfer service-liquid F Expanded API size valves suitable for heat transfer service-vapor* G Expanded API size valves suitable for heat transfer service-liquid* L ASME Code certified for liquid service only S ASME Code Section VIII exposed spring design *Letter suffixes for expanded API sizes where 2-1/2" inlet or outlet has been replaced by 3" size.	0 Special ² 1 Raised Face, ANSI Std. (125 to 160 AARH) 2 Large Female, ANSI Std. 3 Small Male, ANSI Std. 4 Small Female, ANSI Std. 5 Large Tongue, ANSI Std. 6 Large Groove, ANSI Std. 7 Small Tongue, ANSI Std. 8 Small Groove, ANSI Std. 9 Ring Joint (octagonal), ANSI Std. H 63-83 AARH Smooth Finish RF Although not applicable to the Inlet facing only, the following first digit letters are also used: J 63 to 83 AARH (outlet only) K 63 to 83 AARH (inlet & outlet) X High pressure hub style connection	2 Screwed Cap 3 Bolted Cap 4 Packed Lever 7 Open Lever 8 Remoter (with Packed Lever)	0 Without Gag 1 With Gag	See "Materials for Corrosive Service" Table below.
0	150					
1	300 lightweight valve					
2	300 heavyweight valve					
3	600					
4	900					
5	1500					
6	2500					

Materials for Corrosive Service				
Designation	Special Material Description			
	Body Bonnet, Cap	Internal Parts		
		Nozzle & Disc	Other	Springs & Buttons
/S1	Standard	316	316*	316 buttons, Chrome Alloy or High Temperature Alloy Nickel Plated spring
/S3	316	316	316	316 buttons, Chrome Alloy or High Temperature Alloy Nickel Plated spring
/S4	316	316	316	316
/H1	Standard	Hastelloy C	Standard	Standard
/H2	Standard	Hastelloy C	Hastelloy C & Monel	316 buttons, Chrome Alloy or High Temperature Alloy Nickel Plated spring
/H3	Hastelloy C [®]	Hastelloy C	Hastelloy C	316 buttons, Chrome Alloy or High Temperature Alloy Nickel Plated spring
/H4	Hastelloy C	Hastelloy C	Hastelloy C	Hastelloy C
/M1	Standard	Monel	Standard	Standard
/M2	Standard	Monel	Monel	316 buttons, Chrome Alloy or High Temperature Alloy Nickel Plated spring
/M3	Monel	Monel	Monel	316 buttons, Chrome Alloy or High Temperature Alloy Nickel Plated spring
/M4	Monel	Monel	Monel	Inconel spring, Monel buttons
/N1	Carbon Steel (NACE)	316 (NACE)	316*	Standard ³
/N4	316 (NACE)	316 (NACE)	316*	316 ³

* Spring adjusting screw in standard material

General Notes:

- Other special materials, such as 316L stainless steel and Alloy 20, as well as non-standard outlet flange classes are available upon request. In these instances, suffix code "/SP" is used with a brief description of the special requirements.
- Special inlet facings include, but are not limited to, socket or butt weld ends, lens joint and Grayloc[®] fittings. Grayloc is a registered trademark of Grayloc Products, a division of ABB Vetco Gray Inc.
- The springs shown assumes bellows construction. For conventional construction, use Inconel X750[®] spring and stainless steel spring buttons.



2600/2600L Series Conventional

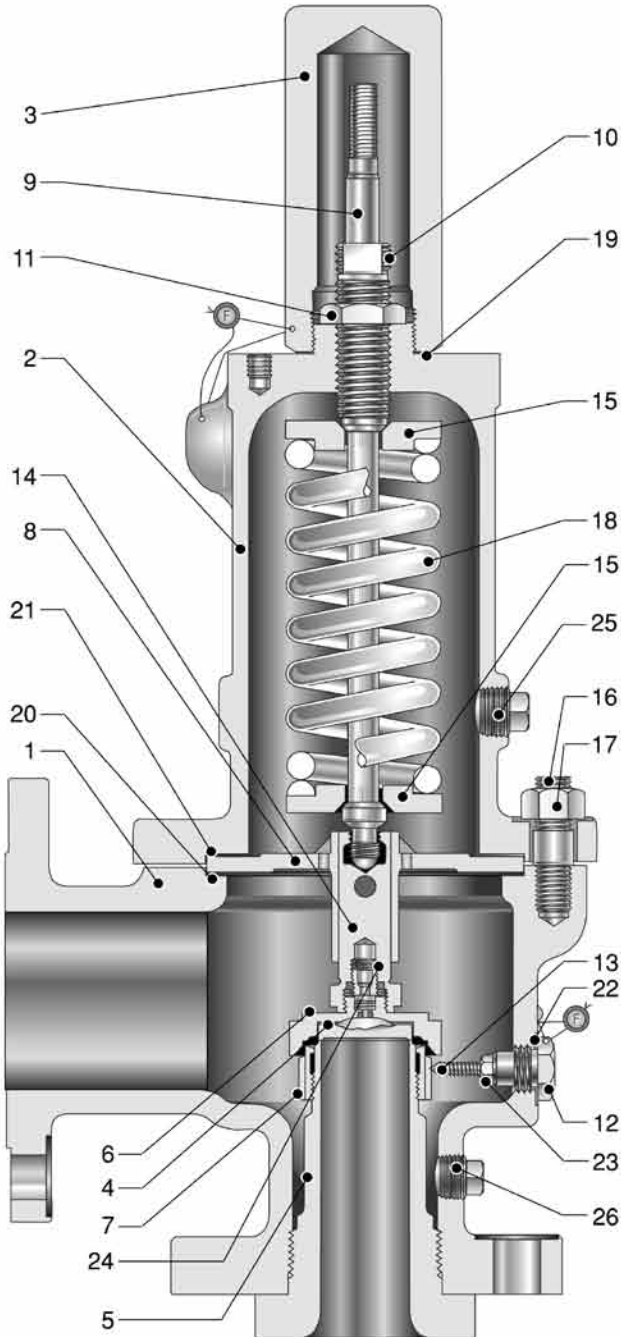

Bill of Materials - Conventional

Item	Part Name	Material
1	Body	SA-216 GR. WCB Carbon Steel ¹
		SA-217 GR. WC6, Alloy St. (1-1/4 CR-1/2 Moly) ²
2	Bonnet	SA-216 GR. WCB Carbon Steel ¹
		SA-217 GR. WC6, Alloy St. (1-1/4 CR-1/2 Moly) ²
3	Cap. Plain Screwed	Carbon Steel
4	Disc	316 St. St.
5	Nozzle	316 St. St.
6	Disc Holder	316 St. St.
7	Blow Down Ring	316 St. St.
8	Sleeve Guide	316 St. St.
9	Stem	316 St. St.
10	Spring Adjusting Screw	Stainless Steel
11	Jam Nut (Spr. Adj. Screw)	316 St. St.
12	Lock Screw (B.D.R.)	316 St. St.
13	Lock Screw Stud	316 St. St.
14	Stem Retainer ⁸	17-4PH St. St.
15	Spring Button	Carbon St., Rust proofed or 316 St. St.
16	Body Stud	ASME SA-193 GR. B7 Alloy St.
17	Hex Nut (Body)	ASME SA-194 GR. 2H Alloy St.
18	Spring	Chrome Alloy Rust Proofed ¹
		High Temperature Alloy Rust Proofed ²
19	Cap Gasket	316 St. St.
20	Body Gasket	316 St. St.
21	Bonnet Gasket	316 St. St.
22	Lock Screw Gasket	316 St. St.
23	Hex Nut (B.D.R.L.S.)	Stainless Steel
24	Lock Screw (D.H.)	Stainless Steel
25	Pipe Plug (Bonnet)	Steel
26	Pipe Plug (Body)	Steel

General Notes:

1. Applies to orifice sizes 26() A10 thru 26() A16.
2. Applies to orifice sizes 26() A32 thru 26() A36.
3. Parentheses in type number indicate orifice designation, as in 26FA10.
4. For corrosive and low temperature materials, see pages 17 through 21.
5. For open and packed lever materials and test gags, see accessories on pages 68 & 69.
6. For capacities, see pages 39-42 U.S. Units, 57-60 Metric Units.
7. For dimensions and weights, see pages 72-75.
8. For 316 Stem Retainer add S1 suffix to Type #.



2600/2600L Series BalanSeal

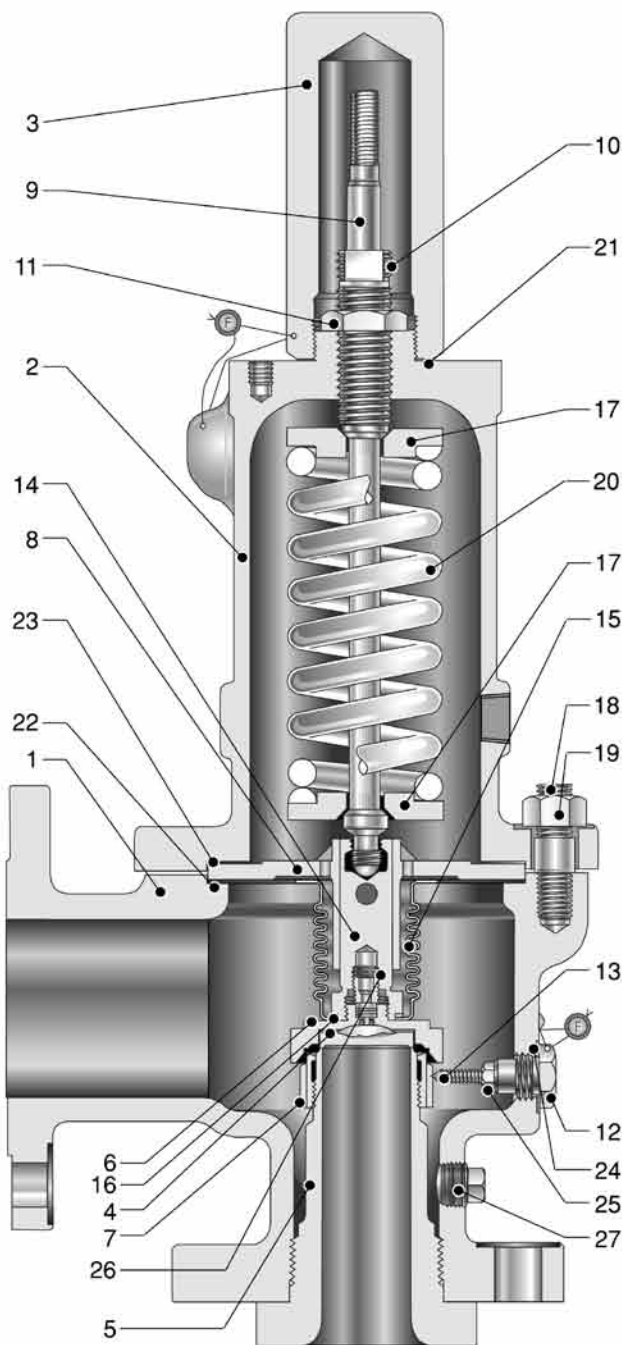

Bill of Materials - BalanSeal

Item	Part Name	Material
1	Body	SA-216 GR. WCB Carbon Steel ¹
		SA-217 GR. WC6, Alloy St. (1-1/4 CR-1/2 Moly) ²
2	Bonnet	SA-216 GR. WCB Carbon Steel ¹
		SA-217 GR. WC6, Alloy St. (1-1/4 CR-1/2 Moly) ²
3	Cap. Plain Screwed	Carbon Steel
4	Disc	316 St. St.
5	Nozzle	316 St. St.
6	Disc Holder	316 St. St.
7	Blow Down Ring	316 St. St.
8	Sleeve Guide	316 St. St.
9	Stem	316 St. St.
10	Spring Adjusting Screw	Stainless Steel
11	Jam Nut (Spr. Adj. Screw)	316 St. St.
12	Lock Screw (B.D.R.)	316 St. St.
13	Lock Screw Stud	316 St. St.
14	Stem Retainer ⁸	17-4PH St. St.
15	Bellows	Inconel Composite
16	Bellows Gasket	Non-Asbestos
17	Spring Button	Carbon St., Rust proofed or 316 St. St
18	Body Stud	ASME SA-193 GR. B7 Alloy St.
19	Hex Nut (Body)	ASME SA-194 GR. 2H Alloy St.
20	Spring	Chrome Alloy Rust Proofed ¹
		High Temperature Alloy Rust Proofed ²
21	Cap Gasket	316 St. St.
22	Body Gasket	316 St. St.
23	Bonnet Gasket	316 St. St.
24	Lock Screw Gasket	316 St. St.
25	Hex Nut (B.D.R.L.S.)	Stainless Steel
26	Lock Screw (D.H.)	Stainless Steel
27	Pipe Plug (Body)	Steel



Built in conformance to ASME Code Section VIII, capacity certified by National Board

General Notes:

1. Applies to orifice sizes 26() A10 thru 26() A16.
2. Applies to orifice sizes 26() A32 thru 26() A36.
3. Parentheses in type number indicate orifice designation, as in 26FA10.
4. For corrosive and low temperature materials, see pages 17 through 21.
5. For open and packed lever materials and test gags, see accessories on pages 68 & 69.
6. For capacities, see pages 39-42 U.S. Units, 57-60 Metric Units.
7. For dimensions and weights, see pages 72-75.
8. For 316 Stem Retainer add S1 suffix to Type #.



2600L Series Certified Design

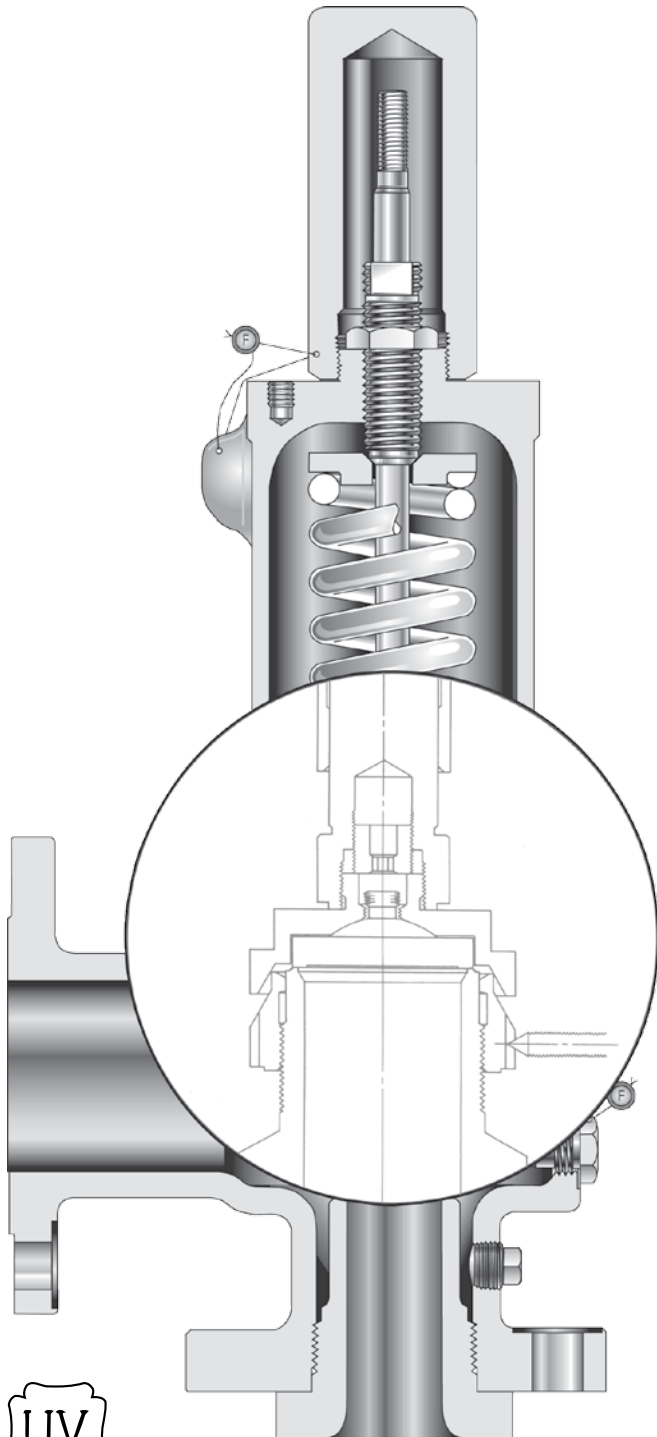

Built in conformance to ASME Code Section VIII,
capacity certified by National Board

The 2600L Series liquid relief valves are for use on ASME Section VIII Code applications and offer a superior valve with greater capacity at 10% overpressure than the traditional 2600 Series.

The 2600L Series complements a full line of pressure relief valves in orifices "D" through "T" to meet the ASME Code requirements for incompressible fluid services. The Code stamped construction requires liquid relief valves that have been capacity certified on water at 10% overpressure to carry the ASME UV and National Board NB symbols.

For compressible fluid services, the standard 2600 Series should be used. Liquid service applications that do not require the use of Code stamped liquid relief valves can still be satisfied with the standard 2600 series line. In most cases the standard 2600 should only be used in liquid service where an existing installation pipe size / orifice combination does not match the 2600L design.

The 2600L Series is also certified under ASME Code Section VIII for use in air, gas, steam, and vapor services. It may be used in those applications or where two phase or flashing fluid service is anticipated. The 2600L is certified as a fixed blow down design whether used in compressible or non-compressible services.

The type number is differentiated from the existing 2600 Series design by adding the letter "L" as a suffix. The letter "L" is used to specify all liquid trim type numbers and always appears in the seventh position of the type number, just before the three-digit option code for inlet facing/cap construction/test gag. Example: 26GA10L-120.

Optional trim material classes and other accessories are available, as with the 2600 Series, with the exceptions of the H2600. All types within the 2600L Series follow the size, pressure-temperature ratings, and center-to-face dimensions of the 2600 Series (API Std. 526).

Traditional Farris convertibility between conventional and bellows is maintained, as is the interchange-ability of parts.

2600S Series Exposed Spring

The 2600S Series safety valves with exposed springs represent an enhancement of the standard 2600 Series and are designed to offer improved performance in steam service. They are built in conformance to Section VIII of the ASME Code and have capacities certified at 10% over-pressure by the National Board of Boiler and Pressure Vessel Inspectors. Series 2600S is available in the same "D" through "Z" orifices and flange classes as the standard 2600 Series, and have the same center-to-face dimensions (API Std. 526).

In steam service, you can encounter galling of the guiding surfaces. To minimize this problem, the guide and stem retainer are made from different materials: 316 stainless steel for the guide and hardened stainless steel for the stem retainer. Since the open bonnet is made from a standard 2600 Series bonnet, all other parts are identical to the 2600 Series to provide maximum interchangeability of parts and to reduce inventory costs.

An open lifting lever, required by ASME Code for steam and air service, is standard with the 2600S Series. Chrome alloy springs are used to 1000° F. They can also be used on air service or on other clean gases. Most other 2600 Series options can be supplied, including O-ring seats and bellows. For weather protection of the spring, use the standard 2600 vapor service valve with open lever.

The type number is differentiated from the 2600 Series by the addition of the suffix letter "S" in the seventh digit of the type number. Example: 26JA10S-170.

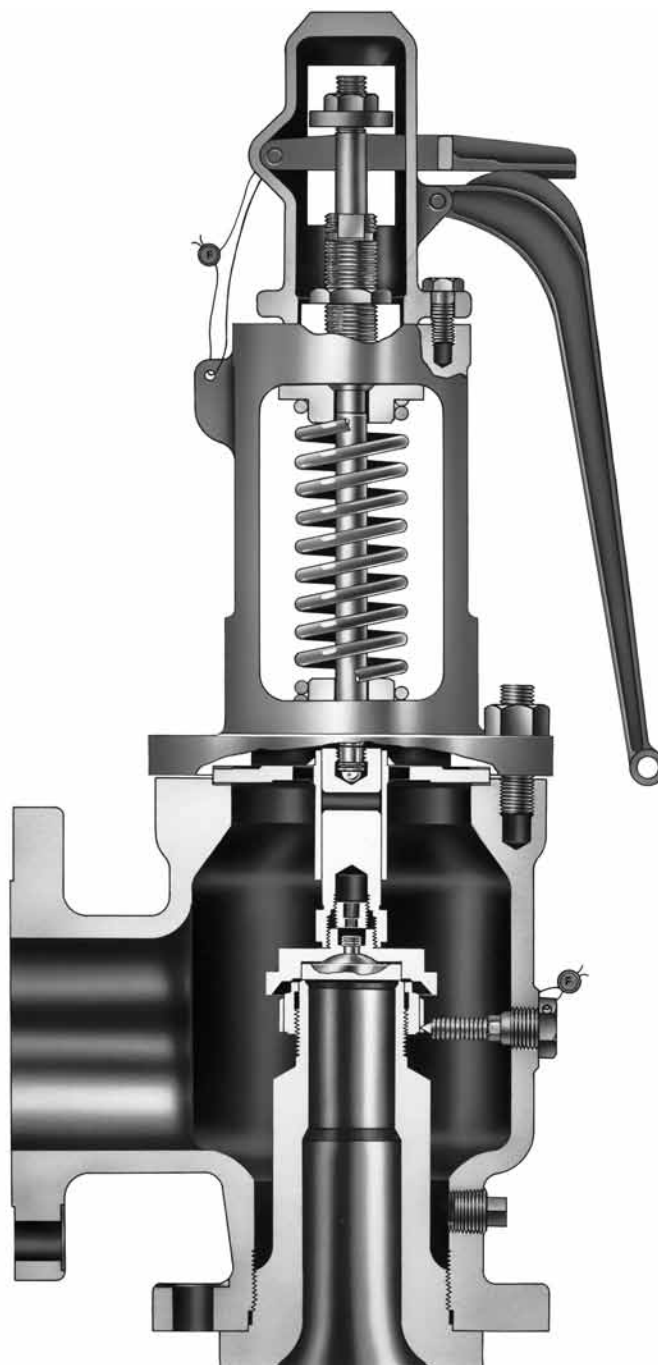

Built in conformance to ASME Code Section VIII,
capacity certified by National Board



2600/2600L Balanced Piston Design

Balanced Bellows with Auxiliary Balancing Piston

Under back pressure conditions, rupture of the bellows can cause an increase in set pressure of the pressure relief valve. Consistent with safety, Farris Engineering offers a BalanSeal/piston design to compensate for a broken or ruptured bellows. The valve features a piston guide that has an inside diameter equal to the average diameter of the bellows convolutions.

If the bellows fails, the effect of the back pressure is nullified by the use of the piston. Since there is a slight diametrical clearance between the piston and the guide, a small amount of lading fluid is permitted to pass through the bonnet vent, indicating a bellows rupture. Although the valve will continue to function as a Farris bellows pressure relief valve, the damaged bellows should be replaced to avoid further product loss.

When the proper orifice and corresponding letter designation have been determined, refer to the selection charts and choose the conventional pressure and temperature required. Sizes, set pressure, back pressure, temperature ratings and capacity data are the same as the BalanSeal construction.

To convert the conventional valve type number to the catalog number for balanced bellows valve with auxiliary balancing piston, insert the letter "E" in place of "A". Example: 26FA12-120 conventional valve becomes 26FE12-120.

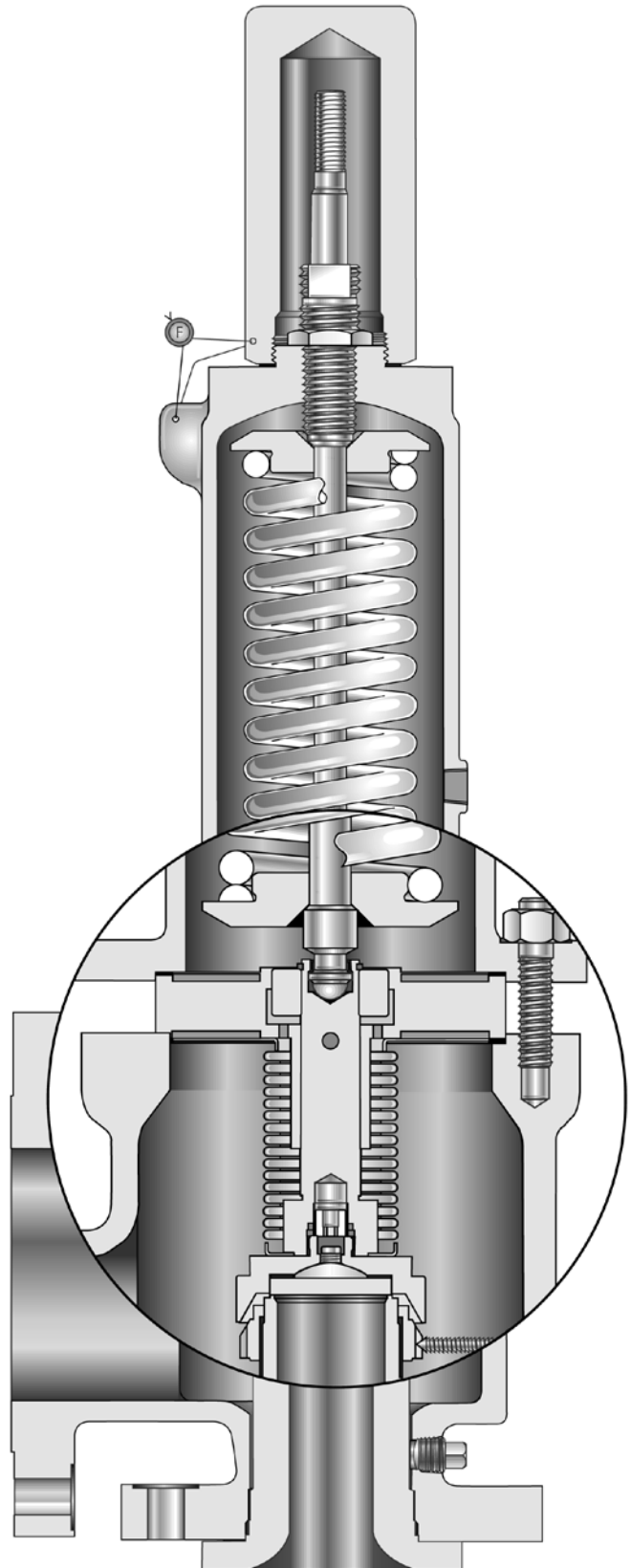

Built in conformance to ASME Code Section VIII,
capacity certified by National Board

2600 Series Heat Transfer Fluid Service

The inherent features of engineering design in the Farris nozzle pressure relief valve make it ideal for heat transfer fluid service. Heat transfer fluids form solid on relief to atmosphere and exhibit non-lubricating qualities. Consequently the valve requires the ultimate in tightness and perfect guiding beyond that of a valve used in other services.

The Farris design includes a 2-1/2 to 1 guiding ratio, self-aligning, flat, easily replaceable disc and double universal joint for exact alignment. These valves have been proven in thousands of installations and are accepted as the industry standard for heat transfer fluid service.

For additional protection against deposit build-up on the guiding surfaces, a BalanSeal bellows can be provided to isolate internal working parts.

All heat transfer fluid service valves receive particular attention in the Farris assembly and testing departments. Special lapping, gasketing and sealing compounds are used to assure maximum tightness for this hard-to-hold service.



Built in conformance to ASME Code Section VIII, capacity certified by National Board

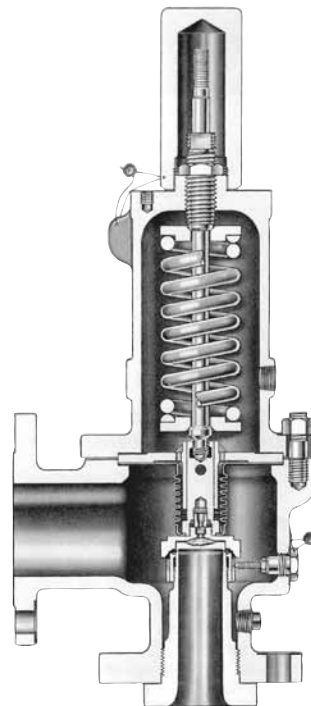

Materials for Corrosive and Low Temperature Service

Standard materials of construction for corrosive service and low temperature service are listed on pages 18-21. Our selection of these materials is a result of many years of research in metallurgy and, while not all-inclusive, covers the most frequently used construction materials. In the case of a special application that requires materials not listed in this catalog, consult the Farris Factory.

Note that Farris Engineering cannot guarantee valve service life, as there are many factors that can affect the life of any material and that are beyond our control.

Corrosive Service. A pressure relief valve is not expected to operate frequently; therefore, standard materials should prove satisfactory. Where severe corrosive conditions exist, the nozzle and disc, which are always exposed to the lading fluid, are available in more corrosive-resistant materials such as Monel (/M1) and Hastelloy C (/H1).

Where specific applications require complete internals to be more corrosion resistant due to frequent valve operation and where parts beyond the nozzle and disc are exposed to corrosive lading fluid, complete internals and the complete valve are available in 316, Monel and Hastelloy (/S3, /S4, /N1, /N4, /M2, /M3, /M4, /H2, /H3, /H4).

Low Temperature Service. For low temperature applications, Farris offers S3 and S4 trim categories, depending on the degree of sub-zero temperatures involved. Materials cover special metallurgy to maintain adequate impact resistance on all stressed parts at sub-zero temperatures.



Standard Material for Corrosive Service 316 St. St.⁶

Part Name	S3 Complete Valve Except Spring Assembly		S4 Complete Valve	
	-75°F TO 800°F		-450°F TO 450°F ³	
	Conventional	BalanSeal	Conventional	BalanSeal
Body	SA-351 Gr. CF8M St. St. (316 St. St.)	SA-351 Gr. CF8M St. St. (316 St. St.)	SA-351 Gr. CF8M St. St. (316 St. St.)	SA-351 Gr. CF8M St. St. (316 St. St.)
Bonnet	SA-351 Gr. CF8M St. St. (316 St. St.)	SA-351 Gr. CF8M St. St. (316 St. St.)	SA-351 Gr. CF8M St. St. (316 St. St.)	SA-351 Gr. CF8M St. St. (316 St. St.)
Cap, Plain Screwed	316 St. St.	316 St. St.	316 St. St.	316 St. St.
Disc				
Nozzle				
Disc Holder				
Blow Down Ring				
Sleeve Guide				
Stem				
Spring Adj. Screw	316 St. St.	316 St. St.	316 St. St.	316 St. St.
Jam Nut (Spr. Adj. Scr.)				
Blow Down Ring Lock Screw				
Lock Screw Stud				
Stem Retainer	316 St. St.	316 St. St.	316 St. St.	316 St. St.
Bellows	None		None	
Bellows Gasket	None	Teflon Composite	None	Teflon Composite
Spring Button	316 St. St.	316 St. St.	316 St. St.	316 St. St.
Body Stud	ASTM A193 Gr. B8M St. St.	ASTM A193 Gr. B8M St. St.	ASTM A193 Gr. B8M St. St.	ASTM A193 Gr. B8M St. St.
Body Hex Nut	ASTM A194 Gr. 8M St. St.	ASTM A194 Gr. 8M St. St.	ASTM A194 Gr. 8M St. St.	ASTM A194 Gr. 8M St. St.
Spring	Chrome Alloy, Nickel Plated	Chrome Alloy, Nickel Plated	316 St. St.	316 St. St.
Cap Gasket				
Bonnet Gasket				
Body Gasket				
Lock Screw Gasket				
Hex. Nut (Lock Screw)				
Disc Holder Lock Screw				
Pipe Plug (Bonnet)	316 St. St.	None	316 St. St.	None
Pipe Plug (Body)	316 St. St.	316 St. St.	316 St. St.	316 St. St.

General Notes:

1. Any part not specified is standard material.
2. Maximum set pressures for S1 trim are equal to the carbon steel valves in the selection tables.
3. Maximum set and back pressures for the S3 and S4 trim are equal to the 316 stainless valve limits shown on pages 24-37, 43-56, 79 and 80.
4. To designate valves with 316 stainless construction, add the appropriate suffix to the type number. Example: 26FA10-120 becomes 26FA10-120/S4.
5. For open and packed lever materials, see page 68.
6. Specify S1 trim to select a valve with a 316 St. St. stem retainer and standard carbon steel body and bonnet.

Standard Material for Corrosive Service Monel

Part Name	M1 Nozzle & Disc		M2 Internal Parts Except Spring Assembly		M3 Complete Valve Except Spring Assembly		M4 Complete Valve	
	-20°F to 800°F ²		-20°F to 800°F ²		-75°F to 800°F ³		-325°F to 900°F ³	
	Conventional	BalanSeal	Conventional	BalanSeal	Conventional	BalanSeal	Conventional	BalanSeal
Body					Monel	Monel	Monel	Monel
Bonnet					Monel	Monel	Monel	Monel
Cap, Plain Screwed					Monel	Monel	Monel	Monel
Disc	Monel	Monel	Monel	Monel	Monel	Monel	Monel	Monel
Nozzle	Monel	Monel	Monel	Monel	Monel	Monel	Monel	Monel
Disc Holder			Monel	Monel	Monel	Monel	Monel	Monel
Blow Down Ring			Monel	Monel	Monel	Monel	Monel	Monel
Sleeve Guide			Monel		Monel	Monel	Monel	Monel
Stem			Monel		Monel	Monel	Monel	Monel
Spring Adj. Screw			Monel		Monel	Monel	Monel	Monel
Jam Nut (Spring Adj. Screw)			Monel		Monel	Monel	Monel	Monel
Blow Down Ring Lock Screw			Monel	Monel	Monel	Monel	Monel	Monel
Lock Screw Stud			Monel	Monel	Monel	Monel	Monel	Monel
Stem Retainer			Monel	Monel	Monel	Monel	Monel	Monel
Bellows	None		None	Monel	None	Monel	None	Monel
Bellows Gasket	None		None	Teflon Composite	None	Teflon Composite	None	Teflon Composite
Spring Button			316 St. St.		316 St. St.	316 St. St.	Monel	Monel
Body Stud					Hastelloy C	Hastelloy C	Hastelloy C	Hastelloy C
Body Hex Nut					Hastelloy C	Hastelloy C	Hastelloy C	Hastelloy C
Spring			Chrome Alloy Nickel Plated		Chrome Alloy Nickel Plated	Chrome Alloy Nickel Plated	Inconel X	Inconel X
Cap Gasket			Monel		Monel	Monel	Monel	Monel
Bonnet Gasket			Monel		Monel	Monel	Monel	Monel
Body Gasket			Monel	Monel	Monel	Monel	Monel	Monel
Lock Screw Gasket			Monel	Monel	Monel	Monel	Monel	Monel
Hex Nut (Lock Screw)			Monel	Monel	Monel	Monel	Monel	Monel
Disc Holder Lock Screw			Monel	Monel	Monel	Monel	Monel	Monel
Pipe Plug (Bonnet)		None		None	Monel	None	Monel	None
Pipe Plug (Body)					Monel	Monel	Monel	Monel

General Notes:

1. Any part not specified is standard material.
2. Maximum set pressures for M1 and M2 trim are equal to the Monel flange limits as shown on page 83. Consult the factory for higher pressures.
3. Maximum set and back pressures for the M3 and M4 trim are equal to the Monel valve limits as shown on page 83.
4. To designate valves with Monel construction, add the appropriate suffix to the type number. Example: 26FA10-120 becomes 26FA10-120/M1.
5. For open and packed lever materials, see page 68.
6. Monel, Inconel and Inconel X are registered trademarks of Inco Alloys International. We reserve the right to substitute comparable materials from other manufacturers.



Standard Material for Corrosive Service Hastelloy C

Part Name	H1 Nozzle & Disc		H2 Internal Parts Except Spring Assembly		H3 Complete Valve Except Spring Assembly		H4 Complete Valve	
	-20°F to 800°F ²		-20°F to 800°F ²		-75°F to 800°F ³		-325°F to 800°F ³	
	Conventional	BalanSeal	Conventional	BalanSeal	Conventional	BalanSeal	Conventional	BalanSeal
Body					Hastelloy C	Hastelloy C	Hastelloy C	Hastelloy C
Bonnet					Hastelloy C	Hastelloy C	Hastelloy C	Hastelloy C
Cap, Plain Screwed					Hastelloy C	Hastelloy C	Hastelloy C	Hastelloy C
Disc	Hastelloy C	Hastelloy C	Hastelloy C	Hastelloy C	Hastelloy C	Hastelloy C	Hastelloy C	Hastelloy C
Nozzle	Hastelloy C	Hastelloy C	Hastelloy C	Hastelloy C	Hastelloy C	Hastelloy C	Hastelloy C	Hastelloy C
Disc Holder			Hastelloy C	Hastelloy C	Hastelloy C	Hastelloy C	Hastelloy C	Hastelloy C
Blow Down Ring			Hastelloy C	Hastelloy C	Hastelloy C	Hastelloy C	Hastelloy C	Hastelloy C
Sleeve Guide			Hastelloy C		Hastelloy C	Hastelloy C	Hastelloy C	Hastelloy C
Stem			Monel		Hastelloy C	Hastelloy C	Hastelloy C	Hastelloy C
Spring Adj. Screw			Monel		Hastelloy C	Hastelloy C	Hastelloy C	Hastelloy C
Jam Nut (Spring Adj. Screw)			Monel		Hastelloy C	Hastelloy C	Hastelloy C	Hastelloy C
Blowdown Ring Lock Screw			Monel	Monel	Hastelloy C	Hastelloy C	Hastelloy C	Hastelloy C
Lock Screw Stud			Monel	Monel	Hastelloy C	Hastelloy C	Hastelloy C	Hastelloy C
Stem Retainer			Hastelloy C	Hastelloy C	Hastelloy C	Hastelloy C	Hastelloy C	Hastelloy C
Bellows	None		None	Inconel Composite Teflon Coated	None	Inconel Composite Teflon Coated	None	Inconel Composite Teflon Coated
Bellows Gasket	None		None	Teflon Composite	None	Teflon Composite	None	Teflon Composite
Spring Button			316 St. St.		316 St. St.	316 St. St.	Hastelloy C	Hastelloy C
Body Stud					Hastelloy C	Hastelloy C	Hastelloy C	Hastelloy C
Body Hex Nut					Hastelloy C	Hastelloy C	Hastelloy C	Hastelloy C
Spring			Chrome Alloy Nickel Plated		Chrome Alloy Nickel Plated	Chrome Alloy Nickel Plated	Hastelloy C	Hastelloy C
Cap Gasket			Monel		Teflon Composite	Teflon Composite	Teflon Composite	Teflon Composite
Bonnet Gasket			Monel		Teflon Composite	Teflon Composite	Teflon Composite	Teflon Composite
Body Gasket			Monel	Monel	Teflon Composite	Teflon Composite	Teflon Composite	Teflon Composite
Lock Screw Gasket			Monel	Monel	Teflon Composite	Teflon Composite	Teflon Composite	Teflon Composite
Hex Nut (Lock Screw)			Monel	Monel	Hastelloy C	Hastelloy C	Hastelloy C	Hastelloy C
Disc Holder Lock Screw			Monel	Monel	Hastelloy C	Hastelloy C	Hastelloy C	Hastelloy C
Pipe Plug (Bonnet)		None		None	Hastelloy C	None	Hastelloy C	None
Pipe Plug (Body)					Hastelloy C	Hastelloy C	Hastelloy C	Hastelloy C

General Notes:

1. Any part not specified is standard material.
2. Maximum set pressures for H1 and H2 trim are equal to the carbon steel valves in the Selection Tables.
3. Maximum set and back pressures for the H3 and H4 trim are equal to the Hastelloy C valve limits shown on pages 81 and 82.
4. To designate valves with Hastelloy C construction, add the appropriate suffix to the type number. Example: 26FA10-120 becomes 26FA10-120/H1.
5. For open and packed lever materials, see page 68.
6. Hastelloy and Hastelloy C are registered trademarks of Haynes International. We reserve the right to substitute comparable materials from other manufacturers.

Pressure Relief Valves for Sour Gas Service

NACE MR0103 and MR0175/ISO 15156

NACE International (formerly The National Association of Corrosion Engineers) publishes two standards covering the use of equipment in environments containing H₂S (Hydrogen Sulfide). The standards are: MR0103, Standard Material Requirements – Materials Resistant to Sulfide Stress Cracking in Corrosive Petroleum Refining Environments; and MR0175/ISO 15156, Petroleum and Natural Gas Industries – Materials for Use in H₂S-Containing Environments in Oil and Gas Production.

The material requirements of the NACE Standards have resulted in various constructions. 2600 Series valves constructed of standard carbon steel (SA216 Grade WCB) and 316 stainless steel (SA351 Grade CF8M or SA479 Type 316) will be dual certified to NACE MR0103 and NACE MR0175/ISO 15156. For non-standard materials, Farris Engineering will have to review the materials on a case-by-case basis to determine NACE compliance.

The customer must decide whether his application requires a valve in compliance with NACE standards. Farris Engineering is responsible for supplying materials in compliance with the applicable NACE specification. As part of the order requirement, Farris will verify that material hardness values are in compliance with the NACE standard on the body, bonnet, nozzle and disc as applicable. Additionally, we will offer bolting and springs (for conventional and pilot operated valves only) in compliance with NACE specifications.

To specify a valve with materials compliant to NACE specifications, add the suffix /N1 or /N4 to the standard type number. Example: 26LB12-120/N1.

Part Name	N1 Suffix		N4 Suffix	
	Conventional	Bellows	Conventional	Bellows
Body	SA216 Gr. WCB (NACE)	SA216 Gr. WCB (NACE)	SA351 Gr. CF8M (NACE)	SA351 Gr. CF8M (NACE)
Bonnet	SA216 Gr. WCB (NACE)	SA216 Gr. WCB (NACE)	SA351 Gr. CF8M (NACE)	SA351 Gr. CF8M (NACE)
Cap, Plain Screwed				
Disc	316 Stainless Steel (NACE)	316 Stainless Steel (NACE)	316 Stainless Steel (NACE)	316 Stainless Steel (NACE)
Nozzle	316 Stainless Steel (NACE)	316 Stainless Steel (NACE)	316 Stainless Steel (NACE)	316 Stainless Steel (NACE)
Disc Holder				
Blow Down Ring				
Sleeve Guide				
Stem				
Spring Adj. Screw				
Jam Nut (Spr. Adj. Scr.)				
Blow Down Ring				
Lock Screw				
Lock Screw Stud				
Stem Retainer				
Bellows	None		None	
Bellows Gasket	None		None	
Spring Button	316 Stainless Steel		316 Stainless Steel	
Body Stud	ASME SA-193 Gr. B7M Alloy Steel	ASME SA-193 Gr. B7M Alloy Steel	ASME SA-193 Gr. B8MA Stainless Steel	ASME SA-193 Gr. B8MA Stainless Steel
Body Hex Nut	ASME SA-194 Gr. 2HM Alloy Steel	ASME SA-194 Gr. 2HM Alloy Steel	ASME SA-194 Gr. 8MA Stainless Steel	ASME SA-194 Gr. 8MA Stainless Steel
Spring	Inconel		Inconel	
Cap Gasket				
Bonnet Gasket				
Body Gasket				
Lock Screw Gasket				
Hex. Nut (Lock Screw)				
Disc Holder Lock Screw				
Pipe Plug (Bonnet)		None		None
Pipe Plug (Body)				

Notes:

1. Any part not specified is standard material. For N1 standard valve, see pages 12-13. For N4, see page 18 S4 trim.
2. For open and packed lever materials, see page 68.
3. For a valve with complete Inconel bellows, use "N1/SP" type number suffix. Example: 26JB10-120/N1/SP.
4. For a valve in complete stainless steel, add "N4" to suffix. Example: 26HB10-120/N4. For optional complete Inconel bellows, add "N4/SP". Example: 26HB10-120/N4/SP.



Farris O-Ring Seat Pressure Seal for Conventional or BalanSeal

The O-ring seat pressure seal minimizes leakage and costly product loss as well as reduces downtime and maintenance on troublesome applications such as:

- Operation too close to set pressure
- Light, hard-to-hold fluids
- Entrained foreign particles and solids
- Vibratory applications
- Corrosive fluids
- Nozzle icing conditions
- Discharge piping strains

Recognizing the need for a resilient seat in a pressure relief valve for extreme tightness, Farris Engineering first produced an O-ring seat in early 1950. The O-ring design received and continues to receive phenomenal acceptance and use because it makes possible complete tightness at pressures much closer to valve set pressure. This tightness is not possible with the standard metal-to-metal seat.

The present Farris O-ring seat seal permits set pressure as high as 1500 psig. Equally important, the spring load is carried solely by the metal-to-metal portion of the seat with the O-ring becoming a pressure seal within its recessed chamber, assuring maximum tightness.

The O-ring seat seal option is available for the 2600/2600L/2600S Series of flanged pressure relief valves in the conventional, BalanSeal, and BalanSeal/piston constructions. Refer to the Selection Tables on pages 24 through 37. Substitute a "C" for the fourth digit "A" in the type number for the conventional valve, a "D" for the fourth digit "B" in the type number for a BalanSeal valve, and an "F" for the fourth digit in the type number for the BalanSeal/piston construction when an O-ring seat seal is required. Valves with Teflon seat seals are available on application.

The same type number changes apply to the 2600L Series. Examples:

- 26FA10 becomes 26FC10 (conventional).
- 26FB10 becomes 26FD10 (BalanSeal).
- 26FA10L becomes 26FC10L (conventional-liquid service).
- 26FE10L becomes 26FF10L (BalanSeal/piston-liquid service).

The set pressure limits of the conventional, BalanSeal, and BalanSeal/piston valves covered in the Selection Tables are the same for the O-ring design in all type numbers and orifices with the class 150, 300, and 600 inlet flanges. Above class 600 inlet flanges, 1500 psig is the limit for the O-ring design, not the conventional limit shown in the Selection Charts and Tables. Refer to the O-Ring Material Selection Chart on page 23 for temperature and pressure ratings of the various elastomeric O-ring materials available.

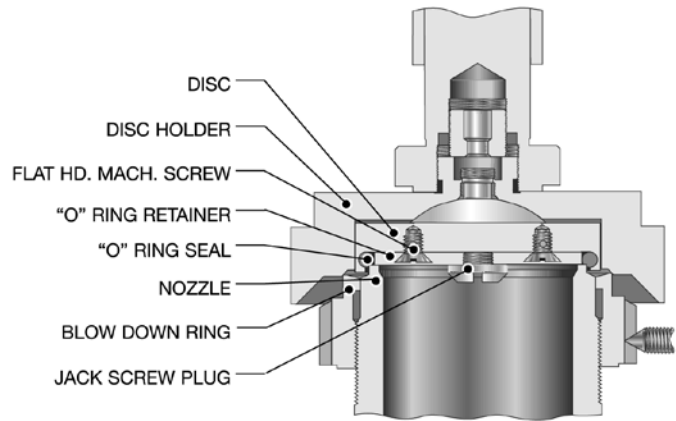

2600 L Through T Orifice
O-Ring Details

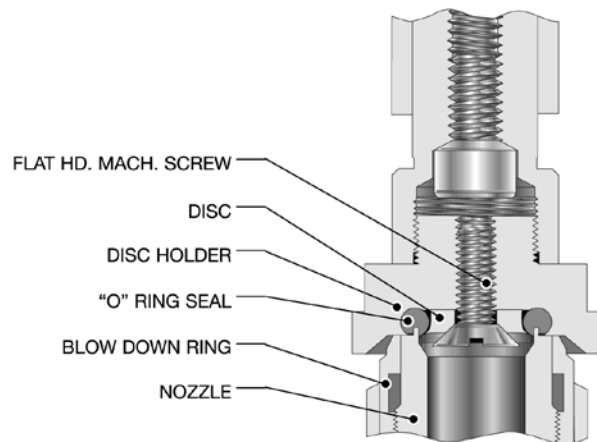

2600 D Through K Orifice
O-Ring Details

Why use an O-ring seat pressure seal?

In the normal operation of a pressure relief valve, the disc must lift off the nozzle very slightly to simmer, allowing pressure build-up within the secondary orifice (huddling chamber), causing the valve to pop fully open. Simmering occurs many times in the process industries where, as a result of process changes, minor upsets, etc., operating pressure fluctuates higher than normal, causing pressure relief valves to simmer but not fully open. This can cause serious misalignment in the valve, and after the pressure drops, the valve will very often continue to leak below the normal operating pressure. The leaking can be overcome by actually popping the valve, but sometimes this is not possible. Use of a Farris O-ring seat pressure seal will always correct this problem.

Frequently operating pressures are too close to valve set pressures. As the operating pressure nears the set pressure, seat loading is diminished, reducing the force that affects tightness. The Farris O-ring seat pressure seal ensures that tightness is achieved at relatively higher operating pressures, much more so than with metal-to-metal or other soft seat pressure relief valves.

On light, hard-to-hold fluids such as hydrogen, helium, light hydrocarbon, anhydrous ammonia, and others, metal-to-metal seats are often penetrated, causing leakage problems. The Farris O-ring seat pressure seal overcomes leakage on these hard-to-hold fluids.

In applications where heavy vibrations occur such as barges, tankers, pumps, and compressors, leakage of metal-to-metal seats develops. This occurs because, as the set pressure nears, the spring force is equalized and the vibration reduces the effect of seat loading, causing leakage. The Farris O-ring seat pressure seal maintains tightness because the spring force is not a factor in the tightness of the O-ring design.

Where occasional minute foreign particles are carried in the flowing medium, metal-to-metal seats are usually marred or scratched when the valve is blowing. This creates leakage problems after the valve closes. The Farris O-ring seat pressure seal absorbs the impact of these particles without damage, and eliminates disc separation from the mating metal seating surface on the nozzle as the valve closes. This reduces the incidence of leakage on most process units. When necessary, simply replace the Farris O-ring to maintain tightness.

Due to corrosion, metal-to-metal seats can eventually leak. With the proper selection of the Farris O-ring seat pressure seal, tightness can be improved and maintained.

Nozzle icing results from the refrigerant effect of the flowing media when a valve relieves. Ice actually forms on the seat, causing leakage. The Farris O-ring seat pressure seal reduces this type of leakage.

"O" RING MATERIAL SELECTION TABLE					
Material	Temperature Range °F	D to K Orifice		L to T Orifice	
		Set Pressure (psig)	Durometer (Shore A)	Set Pressure (psig)	Durometer (Shore A)
Viton ⁴	-20 to 450	15 to 100	50	15 to 150	50
	-20 to 450	101 to 650	75	150 to 450	75
	-20 to 125	650 to 950	75	450 to 750	75
	125 to 450		90		90
	-20 to 450	950 to 1500	90	750 to 1500	90
Ethylene Propylene	0 to 350	15 to 100	50	15 to 150	50
	0 to 350	101 to 650	70	150 to 450	70
	0 to 125	650 to 950	70	450 to 750	70
	125 to 350		80		80
	0 to 350	950 to 1500	80	750 to 1500	80
Buna N	0 to 200	15 to 100	50	15 to 100	50
	0 to 200	101 to 650	70	100 to 450	70
	0 to 125	650 to 950	70	150 to 750	70
	125 to 200		90		90
	0 to 200	950 to 1500	90	750 to 1500	90
Silicone	-150 to 450	15 to 100	50	15 to 100	50
	-150 to 0	101 to 600	50	100 to 200	50
	0 to 450		70		70
	-150 to 450	600 to 850	70	200 to 450	70
	-150 to 125	850 to 1100	70	450 to 750	70
	125 to 450		80		80
	-150 to 450	1100 to 1500	80	750 to 1500	80
Kalrez	-20 to 550	15 to 200	65	15 to 150	65
	-20 to 550	201 to 650	80	150 to 450	80
	-20 to 200	650 to 950	80	450 to 750	80
	200 to 550		90		90
	-20 to 550	950 to 1500	90	750 to 1500	90
Neoprene	-45 to 300	50 to 750	70	50 to 750	70
	-45 to 300	751 to 1500	80	751 to 1500	80

General Notes:

- Standard seat tightness for "O" ring valves is no bubbles at 90% of set pressure for both conventional and bellows valves. At set pressures of 50 psig and below, leakage test shall be made at 5 psig below set pressure.
- Ethylene Propylene is acceptable for steam service up to 350 °F.
- Teflon seat seals available on an application basis. Consult the factory.
- Viton and Kalrez are registered trademarks of DuPont Performance Elastomers. We reserve the right to substitute comparable fluorocarbon materials.



D Orifice

U.S. Customary Units, API Area: 0.110 sq. in., Actual Area: 0.150 sq. in.															
Type Number		Valve Size	ANSI Flange Class		Maximum Set Pressure, psig						Back Pressure Limit psig @ 100°F		Material		Inlet Temp. Range
Conventional	BalanSeal	Inlet Outlet	Inlet RF or RJ	Outlet RF	-450°F -76°F	-75°F -21°F	-20°F +100°F	450°F	800°F	1000°F	Conventional Type	Balan-Seal Type	Body & Bonnet	Spring	
26DA10	26DB10	1 x 2	150#	150#			285	185	80		285	230	Carbon Steel	Chrome Alloy	-20°F to 800°F
26DA11	26DB11	1 x 2	300#	150#			285	285	285		285	230			
26DA12	26DB12	1 x 2	300#	150#			740	615	410		285	230			
26DA13	26DB13	1 x 2	600#	150#			1480	1235	825		285	230			
26DA14		1 1/2 x 2	900#	300#			2220	1845	1235		600	500			
26DA15		1 1/2 x 2	1500#	300#			3705	3080	2060		600	500			
26DA16A		1 1/2 x 3	2500#	300#			6000	5135	3430		740	500			
26DA32	26DB32	1 x 2	300#	150#					510	225	285	230	Chrome Moly Steel	High Temp. Alloy	801°F to 1000°F
26DA33	26DB33	1 x 2	600#	150#					1015	445	285	230			
26DA34		1 1/2 x 2	900#	300#					1525	670	600	500			
26DA35		1 1/2 x 2	1500#	300#					2540	1115	600	500			
26DA36A		1 1/2 x 3	2500#	300#					4230	1860	740	500			
26DA10/S3	26DB10/S3	1 x 2	150#	150#		275					275	230	316 St. St.	Chrome Alloy Nickel Plated	-21°F to -75°F
26DA11/S3	26DB11/S3	1 x 2	300#	150#		275					275	230			
26DA12/S3	26DB12/S3	1 x 2	300#	150#		720					275	230			
26DA13/S3	26DB13/S3	1 x 2	600#	150#		1440					275	230			
26DA14/S3		1 1/2 x 2	900#	300#		2160					600	500			
26DA15/S3		1 1/2 x 2	1500#	300#		3600					600	500			
26DA16A/S3		1 1/2 x 3	2500#	300#		6000					720	500			
26DA10/S4	26DB10/S4	1 x 2	150#	150#	275						275	230	316 St. St.	316 St. St.	-76°F to -450°F
26DA11/S4	26DB11/S4	1 x 2	300#	150#	275						275	230			
26DA12/S4	26DB12/S4	1 x 2	300#	150#	720						275	230			
26DA13/S4	26DB13/S4	1 x 2	600#	150#	1440						275	230			
26DA14/S4		1 1/2 x 2	900#	300#	2160						600	500			
26DA15/S4		1 1/2 x 2	1500#	300#	3600						600	500			
26DA16A/S4		1 1/2 x 3	2500#	300#	4000						720	500			

Selection Chart

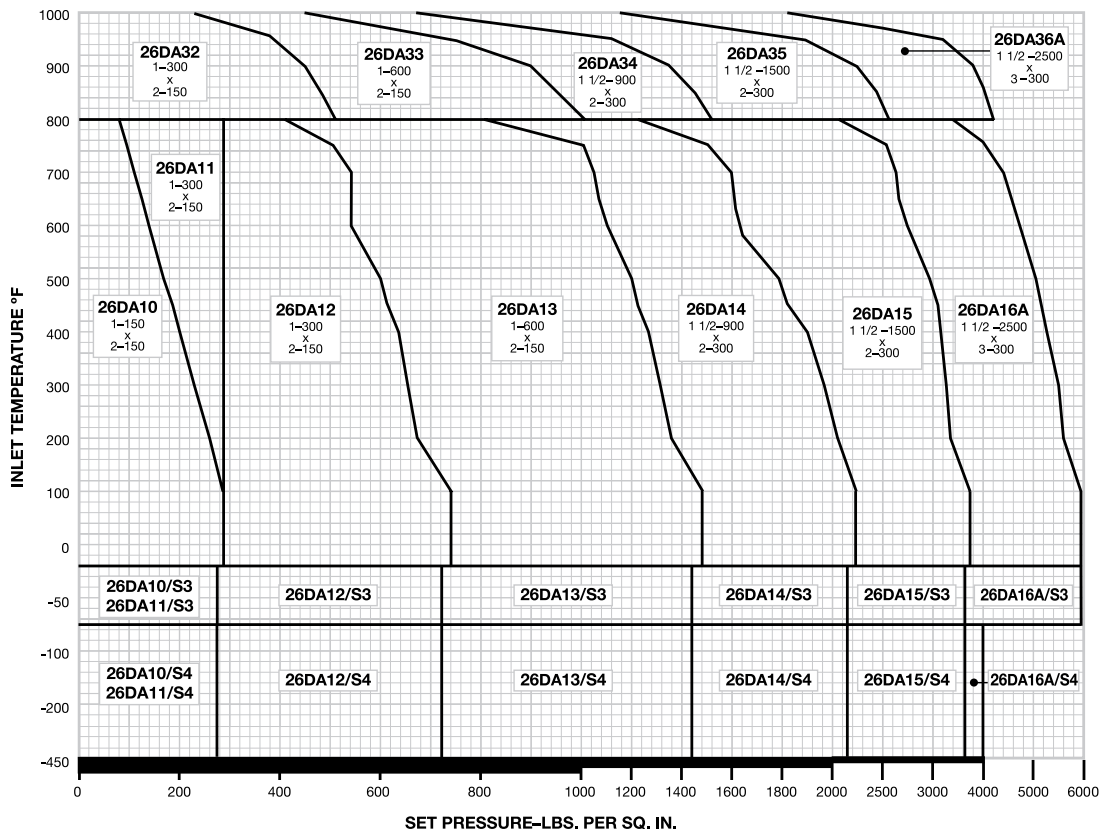

General Notes:

1. The type numbers shown on the Selection Chart indicate conventional valves. For BalanSeal, O-ring construction, balanced piston design and other valve options, see the type numbering system on pages 10 and 11.
2. Outlet pressure for temperatures above 100° F should not exceed the rating in ANSI B16.5.
3. For applications above 1000° F, consult the Farris Factory.

E Orifice

U.S. Customary Units, API Area: 0.196 sq. in., Actual Area: 0.225 sq. in.															
Type Number		Valve Size	ANSI Flange Class		Maximum Set Pressure, psig						Back Pressure Limit psig @ 100°F		Material		Inlet Temp. Range
Conventional	BalanSeal	Inlet Outlet	Inlet RF or RJ	Outlet RF	-450°F -76°F	-75°F -21°F	-20°F +100°F	450°F	800°F	1000°F	Conventional Type	Balan-Seal Type	Body & Bonnet	Spring	
26EA10	26EB10	1 x 2	150#	150#			285	185	80		285	230	Carbon Steel	Chrome Alloy	-20°F to 800°F
26EA11	26EB11	1 x 2	300#	150#			285	285	285		285	230			
26EA12	26EB12	1 x 2	300#	150#			740	615	410		285	230			
26EA13	26EB13	1 x 2	600#	150#			1480	1235	825		285	230			
26EA14		1 1/2 x 2	900#	300#			2220	1845	1235		600	500			
26EA15		1 1/2 x 2	1500#	300#			3705	3080	2060		600	500			
26EA16A		1 1/2 x 3	2500#	300#			6000	5135	3430		740	500			
26EA32	26EB32	1 x 2	300#	150#					510	225	285	230	Chrome Moly Steel	High Temp. Alloy	801°F to 1000°F
26EA33	26EB33	1 x 2	600#	150#					1015	445	285	230			
26EA34		1 1/2 x 2	900#	300#					1525	670	600	500			
26EA35		1 1/2 x 2	1500#	300#					2540	1115	600	500			
26EA36A		1 1/2 x 3	2500#	300#					4230	1860	740	500			
26EA10/S3	26EB10/S3	1 x 2	150#	150#			275				275	230	316 St. St.	Chrome Alloy Nickel Plated	-21°F to -75°F
26EA11/S3	26EB11/S3	1 x 2	300#	150#			275				275	230			
26EA12/S3	26EB12/S3	1 x 2	300#	150#			720				275	230			
26EA13/S3	26EB13/S3	1 x 2	600#	150#			1440				275	230			
26EA14/S3		1 1/2 x 2	900#	300#			2160				600	500			
26EA15/S3		1 1/2 x 2	1500#	300#			3600				600	500			
26EA16A/S3		1 1/2 x 3	2500#	300#			6000				720	500			
26EA10/S4	26EB10/S4	1 x 2	150#	150#	275						275	230	316 St. St.	316 St. St.	-76°F to -450°F
26EA11/S4	26EB11/S4	1 x 2	300#	150#	275						275	230			
26EA12/S4	26EB12/S4	1 x 2	300#	150#	720						275	230			
26EA13/S4	26EB13/S4	1 x 2	600#	150#	1440						275	230			
26EA14/S4		1 1/2 x 2	900#	300#	2160						600	500			
26EA15/S4		1 1/2 x 2	1500#	300#	3600						600	500			
26EA16A/S4		1 1/2 x 3	2500#	300#	4000						720	500			

Selection Chart

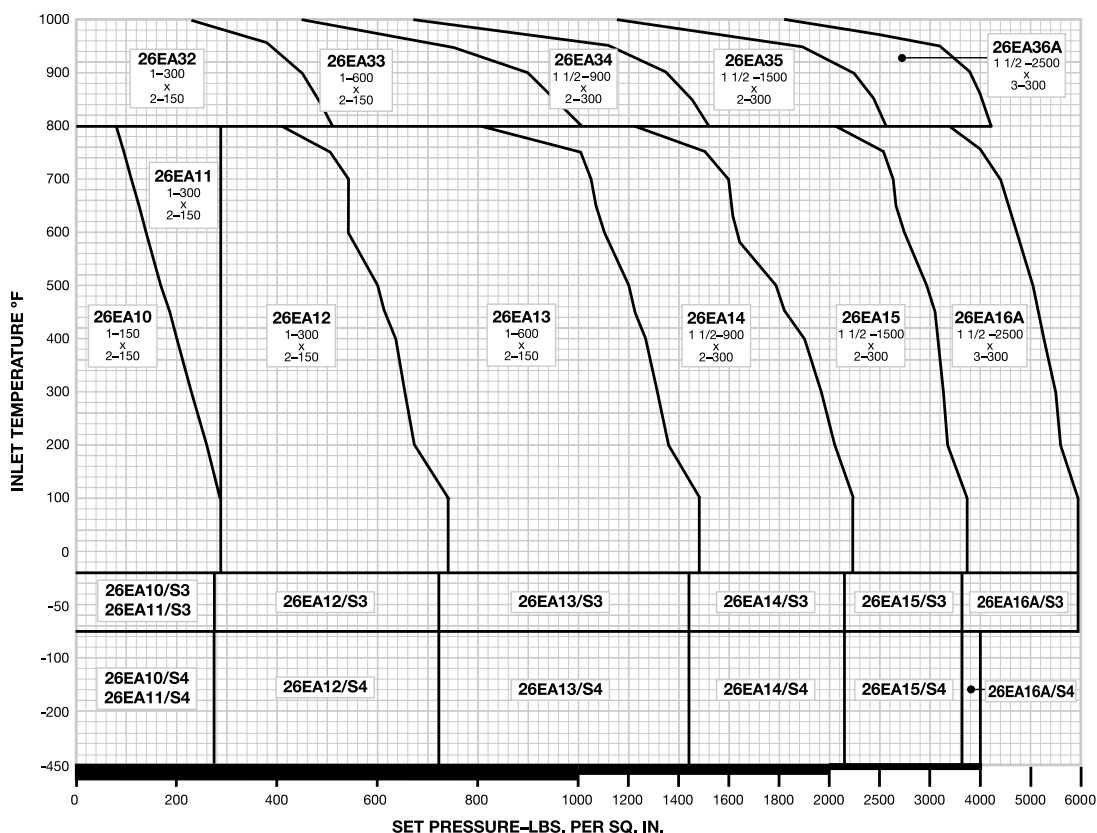

General Notes:

1. The type numbers shown on the Selection Chart indicate conventional valves. For BalanSeal, O-ring construction, balanced piston design and other valve options, see the type numbering system on pages 10 and 11.
2. Outlet pressure for temperatures above 100° F should not exceed the rating in ANSI B16.5.
3. For applications above 1000° F, consult the Farris Factory.



F Orifice

U.S. Customary Units, API Area: 0.307 sq. in., Actual Area: 0.371 sq. in.															
Type Number		Valve Size	ANSI Flange Class		Maximum Set Pressure, psig						Back Pressure Limit psig @ 100°F		Material		Inlet Temp. Range
Conventional	BalanSeal	Inlet Outlet	Inlet RF or RJ	Outlet RF	-450°F -76°F	-75°F -21°F	-20°F +100°F	450°F	800°F	1000°F	Conventional Type	Balan-Seal Type	Body & Bonnet	Spring	
26FA10	26FB10	1 1/2 x 2	150#	150#			285	185	80		285	230	Carbon Steel	Chrome Alloy	-20°F to 800°F
26FA11	26FB11	1 1/2 x 2	300#	150#			285	285	285		285	230			
26FA12	26FB12	1 1/2 x 2	300#	150#			740	615	410		285	230			
26FA13	26FB13	1 1/2 x 2	600#	150#			1480	1235	825		285	230			
26FA14A	26FB14A	1 1/2 x 3	900#	300#			2220	1845	1235		740	500			
26FA15A	26FB15A	1 1/2 x 3	1500#	300#			3705	3080	2060		740	500			
26FA16A	26FB16A	1 1/2 x 3	2500#	300#			5000	5000	3430		740	500			
26FA32	26FB32	1 1/2 x 2	300#	150#					510	225	285	230	Chrome Moly Steel	High Temp. Alloy	801°F to 1000°F
26FA33	26FB33	1 1/2 x 2	600#	150#					1015	445	285	230			
26FA34A	26FB34A	1 1/2 x 3	900#	300#					1525	670	740	500			
26FA35A	26FB35A	1 1/2 x 3	1500#	300#					2540	1115	740	500			
26FA36A	26FB36A	1 1/2 x 3	2500#	300#					4230	1860	740	500			
26FA10/S3	26FB10/S3	1 1/2 x 2	150#	150#		275					275	230	316 St. St.	Chrome Alloy Nickel Plated	-21°F to -75°F
26FA11/S3	26FB11/S3	1 1/2 x 2	300#	150#		275					275	230			
26FA12/S3	26FB12/S3	1 1/2 x 2	300#	150#		720					275	230			
26FA13/S3	26FB13/S3	1 1/2 x 2	600#	150#		1440					275	230			
26FA14A/S3	26FB14A/S3	1 1/2 x 3	900#	300#		2160					720	500			
26FA15A/S3	26FB15A/S3	1 1/2 x 3	1500#	300#		3600					720	500			
26FA16A/S3	26FB16A/S3	1 1/2 x 3	2500#	300#		5000					720	500			
26FA10/S4	26FB10/S4	1 1/2 x 2	150#	150#	275						275	230	316 St. St.	316 St. St.	-76°F to -450°F
26FA11/S4	26FB11/S4	1 1/2 x 2	300#	150#	275						275	230			
26FA12/S4	26FB12/S4	1 1/2 x 2	300#	150#	720						275	230			
26FA13/S4	26FB13/S4	1 1/2 x 2	600#	150#	1440						275	230			
26FA14A/S4	26FB14A/S4	1 1/2 x 3	900#	300#	2160						720	500			
26FA15A/S4	26FB15A/S4	1 1/2 x 3	1500#	300#	2200						720	500			
26FA16A/S4	26FB16A/S4	1 1/2 x 3	2500#	300#	3400						720	500			

Selection Chart

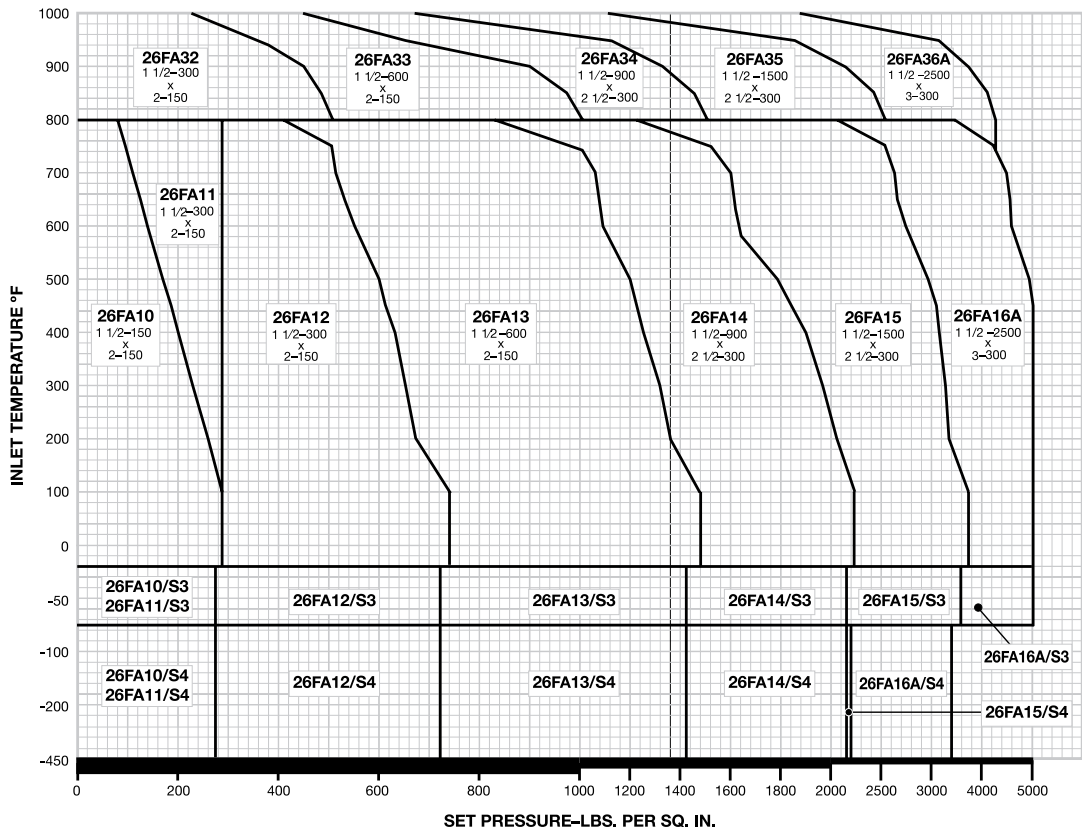

General Notes:

- The type numbers shown on the Selection Chart indicate conventional valves. For BalanSeal, O-ring construction, balanced piston design and other valve options, see the type numbering system on pages 10 and 11.
- Outlet pressure for temperatures above 100° F should not exceed the rating in ANSI B16.5.
- For applications above 1000° F, consult the Farris Factory.

G Orifice

U.S. Customary Units, API Area: 0.503 sq. in., Actual Area: 0.559 sq. in.															
Type Number		Valve Size	ANSI Flange Class		Maximum Set Pressure, psig						Back Pressure Limit psig @ 100°F		Material		Inlet Temp. Range
Conventional	BalanSeal	Inlet Outlet	Inlet RF or RJ	Outlet RF	-450°F -76°F	-75°F -21°F	-20°F +100°F	450°F	800°F	1000°F	Conventional Type	Balan-Seal Type	Body & Bonnet	Spring	
26GA10A	26GB10A	1 1/2 x 3	150#	150#			285	185	80		285	230	Carbon Steel	Chrome Alloy	-20°F to 800°F
26GA11A	26GB11A	1 1/2 x 3	300#	150#			285	285	285		285	230			
26GA12A	26GB12A	1 1/2 x 3	300#	150#			740	615	410		285	230			
26GA13A	26GB13A	1 1/2 x 3	600#	150#			1480	1235	825		285	230			
26GA14A	26GB14A	1 1/2 x 3	900#	300#			2220	1845	1235		740	470			
26GA15	26GB15	2 x 3	1500#	300#			3705	3080	2060		740	470			
26GA16	26GB16	2 x 3	2500#	300#			3705	3705	3430		740	470			
26GA32A	26GB32A	1 1/2 x 3	300#	150#					510	225	285	230	Chrome Moly Steel	High Temp. Alloy	801°F to 1000°F
26GA33A	26GB33A	1 1/2 x 3	600#	150#					1015	445	285	230			
26GA34A	26GB34A	1 1/2 x 3	900#	300#					1525	670	740	470			
26GA35	26GB35	2 x 3	1500#	300#					2540	1115	740	470			
26GA36	26GB36	2 x 3	2500#	300#					3705	1860	740	470			
26GA10A/S3	26GB10A/S3	1 1/2 x 3	150#	150#		275					275	230	316 St. St.	Chrome Alloy Nickel Plated	-21°F to -75°F
26GA11A/S3	26GB11A/S3	1 1/2 x 3	300#	150#		275					275	230			
26GA12A/S3	26GB12A/S3	1 1/2 x 3	300#	150#		720					275	230			
26GA13A/S3	26GB13A/S3	1 1/2 x 3	600#	150#		1440					275	230			
26GA14A/S3	26GB14A/S3	1 1/2 x 3	900#	300#		2160					720	470			
26GA15/S3	26GB15/S3	2 x 3	1500#	300#		3600					720	470			
26GA16/S3	26GB16/S3	2 x 3	2500#	300#		3600					720	470			
26GA10A/S4	26GB10A/S4	1 1/2 x 3	150#	150#	275						275	230	316 St. St.	316 St. St.	-76°F to -450°F
26GA11A/S4	26GB11A/S4	1 1/2 x 3	300#	150#	275						275	230			
26GA12A/S4	26GB12A/S4	1 1/2 x 3	300#	150#	720						275	230			
26GA13A/S4	26GB13A/S4	1 1/2 x 3	600#	150#	1440						275	230			
26GA14A/S4	26GB14A/S4	1 1/2 x 3	900#	300#	1600						600	470			
26GA15/S4	26GB15/S4	2 x 3	1500#	300#	2450						600	470			
26GA16/S4	26GB16/S4	2 x 3	2500#	300#	2600						720	470			

Selection Chart

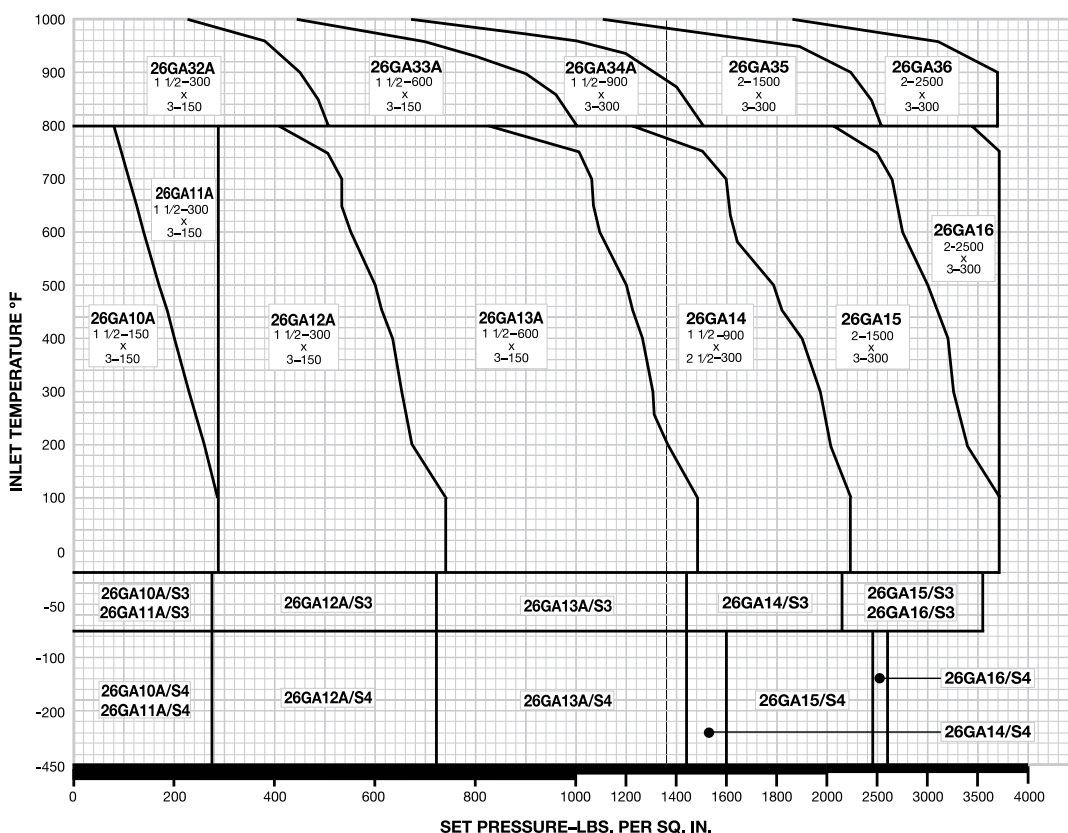

General Notes:

- The type numbers shown on the Selection Chart indicate conventional valves. For BalanSeal, O-ring construction, balanced piston design and other valve options, see the type numbering system on pages 10 and 11.
- Outlet pressure for temperatures above 100° F should not exceed the rating in ANSI B16.5.
- For applications above 1000° F, consult the Farris Factory.



H Orifice

U.S. Customary Units, API Area: 0.785 sq. in., Actual Area: 0.873 sq. in.															
Type Number		Valve Size	ANSI Flange Class		Maximum Set Pressure, psig						Back Pressure Limit psig @ 100°F		Material		Inlet Temp. Range
Conventional	BalanSeal	Inlet Outlet	Inlet RF or RJ	Outlet RF	-450°F -76°F	-75°F -21°F	-20°F +100°F	450°F	800°F	1000°F	Conventional Type	Balan-Seal Type	Body & Bonnet	Spring	
26HA10	26HB10	1 1/2 x 3	150#	150#			285	185	80		285	230	Carbon Steel	Chrome Alloy	-20°F to 800°F
26HA11	26HB11	1 1/2 x 3	300#	150#			285	285	285		285	230			
26HA12	26HB12	2 x 3	300#	150#			740	615	410		285	230			
26HA13	26HB13	2 x 3	600#	150#			1480	1235	825		285	230			
26HA14	26HB14	2 x 3	900#	150#			2220	1845	1235		285	230			
26HA15	26HB15	2 x 3	1500#	300#			2750	2750	2060		740	415			
26HA32	26HB32	2 x 3	300#	150#				510	225		285	230	Chrome Moly Steel	High Temp. Alloy	801°F to 1000°F
26HA33	26HB33	2 x 3	600#	150#				815	445		285	230			
26HA34	26HB34	2 x 3	900#	150#				1225	670		285	230			
26HA35	26HB35	2 x 3	1500#	300#				2040	1115		740	415			
26HA10/S3	26HB10/S3	1 1/2 x 3	150#	150#		275					275	230	316 St. St.	Chrome Alloy Nickel Plated	-21°F to -75°F
26HA11/S3	26HB11/S3	1 1/2 x 3	300#	150#		275					275	230			
26HA12/S3	26HB12/S3	2 x 3	300#	150#		720					275	230			
26HA13/S3	26HB13/S3	2 x 3	600#	150#		1440					275	230			
26HA14/S3	26HB14/S3	2 x 3	900#	150#		2160					275	230			
26HA15/S3	26HB15/S3	2 x 3	1500#	300#		2750					720	415			
26HA10/S4	26HB10/S4	1 1/2 x 3	150#	150#	275						275	230	316 St. St.	316 St. St.	-76°F to -450°F
26HA11/S4	26HB11/S4	1 1/2 x 3	300#	150#	275						275	230			
26HA12/S4	26HB12/S4	2 x 3	300#	150#	720						275	230			
26HA13/S4	26HB13/S4	2 x 3	600#	150#	1440						275	230			
26HA14/S4	26HB14/S4	2 x 3	900#	150#	1485						275	230			
26HA15/S4	26HB15/S4	2 x 3	1500#	300#	1600						720	415			

Selection Chart

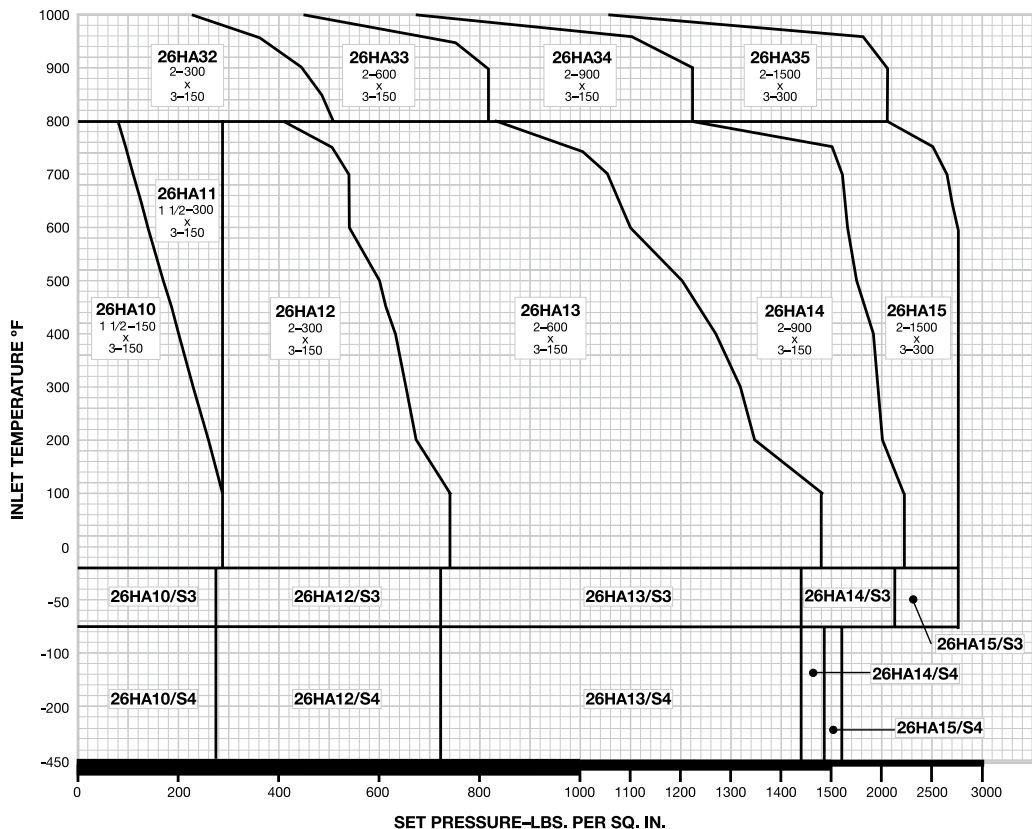

General Notes:

1. The type numbers shown on the Selection Chart indicate conventional valves. For BalanSeal, O-ring construction, balanced piston design and other valve options, see the type numbering system on pages 10 and 11.
2. Outlet pressure for temperatures above 100° F should not exceed the rating in ANSI B16.5.
3. For applications above 1000° F, consult the Farris Factory.

J Orifice

U.S. Customary Units, API Area: 1.287 sq. in., Actual Area: 1.430 sq. in.															
Type Number		Valve Size	ANSI Flange Class		Maximum Set Pressure, psig						Back Pressure Limit psig @ 100°F		Material		Inlet Temp. Range
Conventional	BalanSeal	Inlet Outlet	Inlet RF or RJ	Outlet RF	-450°F -76°F	-75°F -21°F	-20°F +100°F	450°F	800°F	1000°F	Conventional Type	Balan-Seal Type	Body & Bonnet	Spring	
26JA10	26JB10	2 x 3	150#	150#			285	185	80		285	230	Carbon Steel	Chrome Alloy	-20°F to 800°F
26JA11	26JB11	2 x 3	300#	150#			285	285	285		285	230			
26JA12A	26JB12A	3 x 4	300#	150#			740	615	410		285	230			
26JA13A	26JB13A	3 x 4	600#	150#			1480	1235	825		285	230			
26JA14	26JB14	3 x 4	900#	150#			2220	1845	1235		285	230			
26JA15	26JB15	3 x 4	1500#	300#			2700	2700	2060		600	230			
26JA32A	26JB32A	3 x 4	300#	150#				510	225		285	230	Chrome Moly Steel	High Temp. Alloy	801°F to 1000°F
26JA33A	26JB33A	3 x 4	600#	150#				815	445		285	230			
26JA34A	26JB34A	3 x 4	900#	150#				1225	670		285	230			
26JA35	26JB35	3 x 4	1500#	300#				2040	1115		600	230			
26JA10/S3	26JB10/S3	2 x 3	150#	150#		275					275	230	316 St. St.	Chrome Alloy Nickel Plated	-21°F to -75°F
26JA11/S3	26JB11/S3	2 x 3	300#	150#		275					275	230			
26JA12A/S3	26JB12A/S3	3 x 4	300#	150#		720					275	230			
26JA13A/S3	26JB13A/S3	3 x 4	600#	150#		1440					275	230			
26JA14/S3	26JB14/S3	3 x 4	900#	150#		2160					275	230			
26JA15/S3	26JB15/S3	3 x 4	1500#	300#		2700					600	230			
26JA10/S4	26JB10/S4	2 x 3	150#	150#	275						275	230	316 St. St.	316 St. St.	-76°F to -450°F
26JA11/S4	26JB11/S4	2 x 3	300#	150#	275						275	230			
26JA12A/S4	26JB12A/S4	3 x 4	300#	150#	500						275	230			
26JA13A/S4	26JB13A/S4	3 x 4	600#	150#	625						275	230			
26JA14/S4	26JB14/S4	3 x 4	900#	150#	800						275	230			
26JA15/S4	26JB15/S4	3 x 4	1500#	300#	800						600	230			

Selection Chart

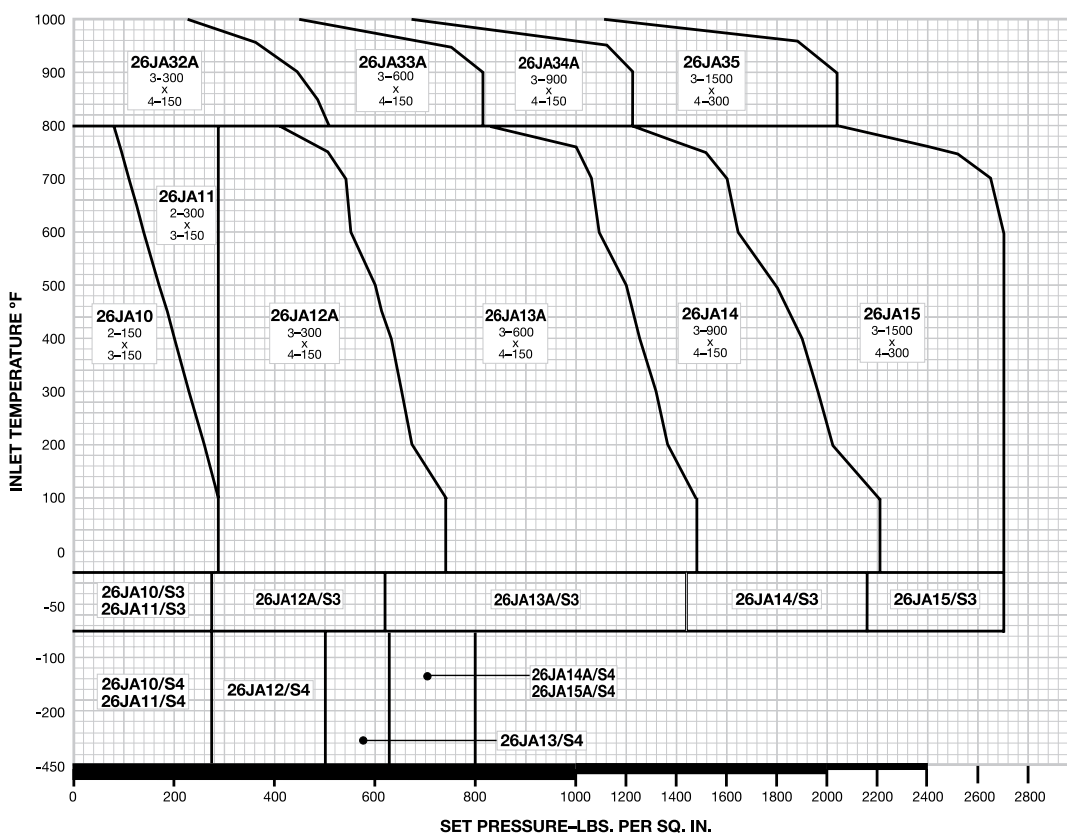

General Notes:

1. The type numbers shown on the Selection Chart indicate conventional valves. For BalanSeal, O-ring construction, balanced piston design and other valve options, see the type numbering system on pages 10 and 11.
2. Outlet pressure for temperatures above 100° F should not exceed the rating in ANSI B16.5.
3. For applications above 1000° F, consult the Farris Factory.



K Orifice

U.S. Customary Units, API Area: 1.838 sq. in., Actual Area: 2.042 sq. in.															
Type Number		Valve Size	ANSI Flange Class		Maximum Set Pressure, psig						Back Pressure Limit psig @ 100°F		Material		Inlet Temp. Range
Conventional	BalanSeal	Inlet Outlet	Inlet RF or RJ	Outlet RF	-450°F -76°F	-75°F -21°F	-20°F +100°F	450°F	800°F	1000°F	Conventional Type	BalanSeal Type	Body & Bonnet	Spring	
26KA10	26KB10	3 x 4	150#	150#			285	185	80		285	150	Carbon Steel	Chrome Alloy	-20°F to 800°F
26KA11	26KB11	3 x 4	300#	150#			285	285	285		285	150			
26KA12	26KB12	3 x 4	300#	150#			740	615	410		285	150			
26KA13	26KB13	3 x 4	600#	150#			1480	1235	825		285	200			
26KA14	26KB14	3 x 6	900#	150#			2220	1845	1235		285	200			
26KA15	26KB15	3 x 6	1500#	300#			2220	2220	2060		600	200			
26KA32	26KB32	3 x 4	300#	150#					510	225	285	150	Chrome Moly Steel	High Temp. Alloy	801°F to 1000°F
26KA33	26KB33	3 x 4	600#	150#					815	445	285	200			
26KA34A	26KB34A	3 x 6	900#	150#					1225	670	285	200			
26KA35	26KB35	3 x 6	1500#	300#					2040	1115	600	200			
26KA10/S3	26KB10/S3	3 x 4	150#	150#		275					275	150	316 St. St.	Chrome Alloy Nickel Plated	-21°F to -75°F
26KA11/S3	26KB11/S3	3 x 4	300#	150#		275					275	150			
26KA12/S3	26KB12/S3	3 x 4	300#	150#		720					275	150			
26KA13/S3	26KB13/S3	3 x 4	600#	150#		1440					275	200			
26KA14/S3	26KB14/S3	3 x 6	900#	150#		2160					275	200			
26KA15/S3	26KB15/S3	3 x 6	1500#	300#		2220					600	200			
26KA10/S4	26KB10/S4	3 x 4	150#	150#	275						275	150	316 St. St.	316 St. St.	-76°F to -450°F
26KA11/S4	26KB11/S4	3 x 4	300#	150#	275						275	150			
26KA12/S4	26KB12/S4	3 x 4	300#	150#	525						275	150			
26KA13/S4	26KB13/S4	3 x 4	600#	150#	600						275	200			
26KA14/S4	26KB14/S4	3 x 6	900#	150#	600						275	200			
26KA15/S4	26KB15/S4	3 x 6	1500#	300#	750						600	200			

Selection Chart

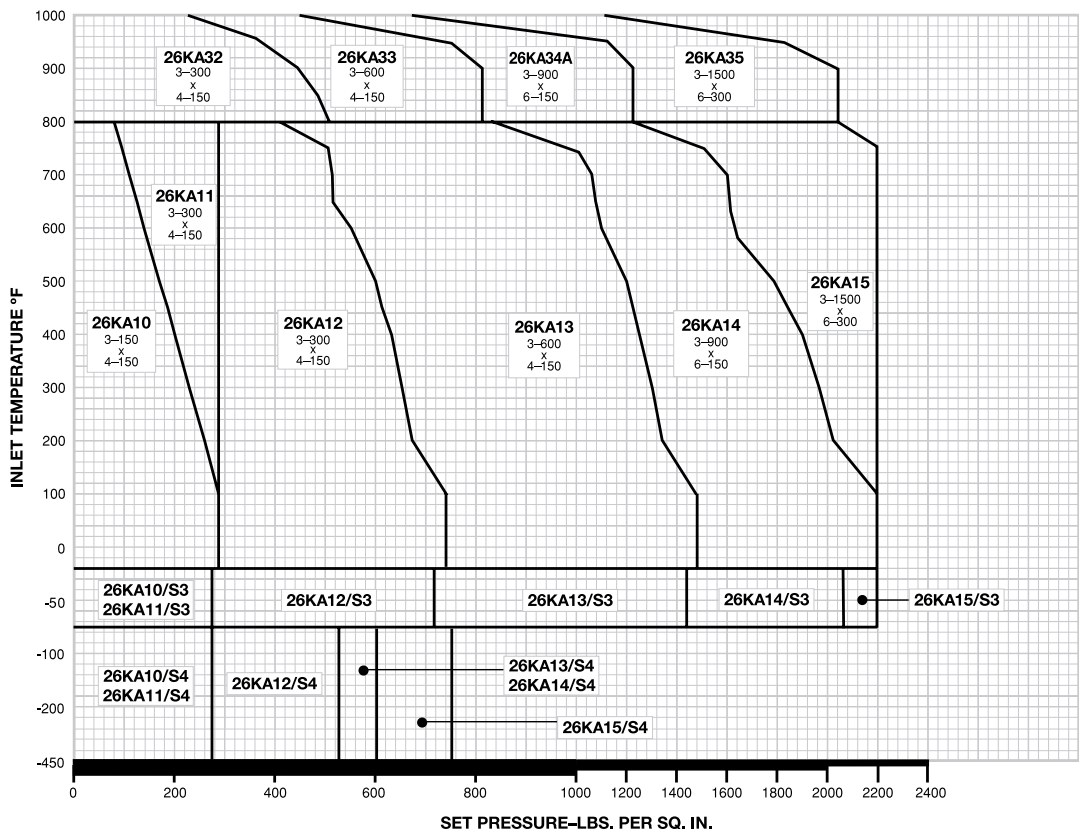

General Notes:

1. The type numbers shown on the Selection Chart indicate conventional valves. For BalanSeal, O-ring construction, balanced piston design and other valve options, see the type numbering system on pages 10 and 11.
2. Outlet pressure for temperatures above 100° F should not exceed the rating in ANSI B16.5.
3. For applications above 1000° F, consult the Farris Factory.

L Orifice

U.S. Customary Units, API Area: 2.853 sq. in., Actual Area: 3.170 sq. in.															
Type Number		Valve Size	ANSI Flange Class		Maximum Set Pressure, psig						Back Pressure Limit psig @ 100°F		Material		Inlet Temp. Range
Conventional	BalanSeal	Inlet Outlet	Inlet RF or RJ	Outlet RF	-450°F -76°F	-75°F -21°F	-20°F +100°F	450°F	800°F	1000°F	Conventional Type	Balan-Seal Type	Body & Bonnet	Spring	
26LA10	26LB10	3 x 4	150#	150#			285	185	80		285	100	Carbon Steel	Chrome Alloy	-20°F to 800°F
26LA11	26LB11	3 x 4	300#	150#			285	285	285		285	100			
26LA12	26LB12	4 x 6	300#	150#			740	615	410		285	170			
26LA13	26LB13	4 x 6	600#	150#			1000	1000	825		285	170			
26LA14	26LB14	4 x 6	900#	150#			1500	1500	1235		285	170			
26LA15	26LB15	4 x 6	1500#	150#			1500	1500	1500		285	170			
26LA32	26LB32	4 x 6	300#	150#					510	225	285	170	Chrome Moly Steel	High Temp. Alloy	801°F to 1000°F
26LA33	26LB33	4 x 6	600#	150#					1000	445	285	170			
26LA34	26LB34	4 x 6	900#	150#					1500	670	285	170			
26LA35	26LB35	4 x 6	1500#	150#					1500	1115	285	170			
26LA10/S3	26LB10/S3	3 x 4	150#	150#		275					275	100	316 St. St.	Chrome Alloy Nickel Plated	-21°F to -75°F
26LA11/S3	26LB11/S3	3 x 4	300#	150#		275					275	100			
26LA12/S3	26LB12/S3	4 x 6	300#	150#		720					275	170			
26LA13/S3	26LB13/S3	4 x 6	600#	150#		1000					275	170			
26LA14/S3	26LB14/S3	4 x 6	900#	150#		1500					275	170			
26LA10/S4	26LB10/S4	3 x 4	150#	150#	275						275	170	316 St. St.	316 St. St.	-76°F to -450°F
26LA11/S4	26LB11/S4	3 x 4	300#	150#	275						275	170			
26LA12/S4	26LB12/S4	4 x 6	300#	150#	535						275	170			
26LA13/S4	26LB13/S4	4 x 6	600#	150#	535						275	170			
26LA14/S4	26LB14/S4	4 x 6	900#	150#	700						275	170			

Selection Chart

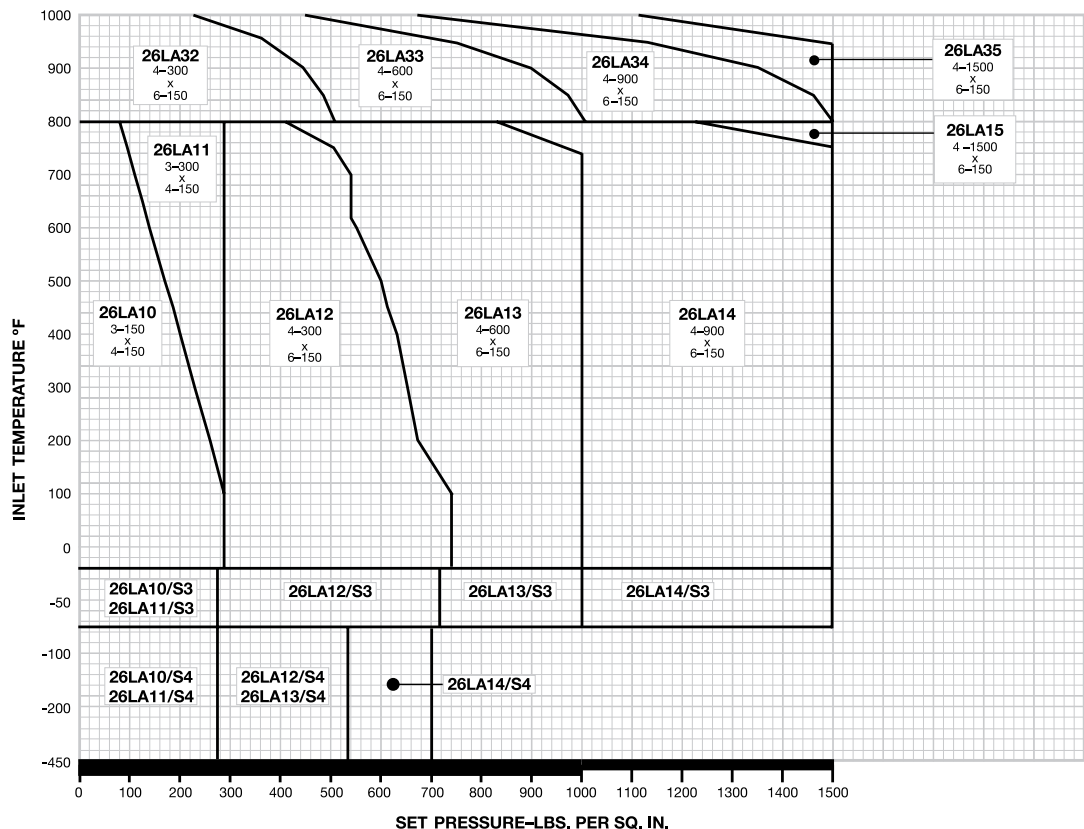

- General Notes:
- The type numbers shown on the Selection Chart indicate conventional valves. For BalanSeal, O-ring construction, balanced piston design and other valve options, see the type numbering system on pages 10 and 11.
 - Outlet pressure for temperatures above 100° F should not exceed the rating in ANSI B16.5.
 - For applications above 1000° F, consult the Farris Factory.



M Orifice

U.S. Customary Units, API Area: 3.60 sq. in., Actual Area: 4.000 sq. in.															
Type Number		Valve Size	ANSI Flange Class		Maximum Set Pressure, psig						Back Pressure Limit psig @ 100°F		Material		Inlet Temp. Range
Conventional	BalanSeal	Inlet Outlet	Inlet RF or RJ	Outlet RF	-450°F -76°F	-75°F -21°F	-20°F +100°F	450°F	800°F	1000°F	Conventional Type	Balan-Seal Type	Body & Bonnet	Spring	
26MA10	26MB10	4 x 6	150#	150#			285	185	80		285	80	Carbon Steel	Chrome Alloy	-20°F to 800°F
26MA11	26MB11	4 x 6	300#	150#			285	285	285		285	80			
26MA12	26MB12	4 x 6	300#	150#			740	615	410		285	160			
26MA13	26MB13	4 x 6	600#	150#			1100	1100	825		285	160			
26MA14	26MB14	4 x 6	900#	150#			1100	1100	1100		285	160			
26MA32	26MB32	4 x 6	300#	150#					510	225	285	160	Chrome Moly Steel	High Temp. Alloy	801°F to 1000°F
26MA33	26MB33	4 x 6	600#	150#					1015	445	285	160			
26MA34	26MB34	4 x 6	900#	150#					1100	670	285	160			
26MA10/S3	26MB10/S3	4 x 6	150#	150#		275					275	80	316 St. St.	Chrome Alloy Nickel Plated	-21°F to -75°F
26MA11/S3	26MB11/S3	4 x 6	300#	150#		275					275	80			
26MA12/S3	26MB12/S3	4 x 6	300#	150#		720					275	160			
26MA13/S3	26MB13/S3	4 x 6	600#	150#		1000					275	160			
26MA10/S4	26MB10/S4	4 x 6	150#	150#	275						275	80	316 St. St.	316 St. St.	-76°F to -450°F
26MA11/S4	26MB11/S4	4 x 6	300#	150#	275						275	80			
26MA12/S4	26MB12/S4	4 x 6	300#	150#	525						275	160			
26MA13/S4	26MB13/S4	4 x 6	600#	150#	600						275	160			

Selection Chart

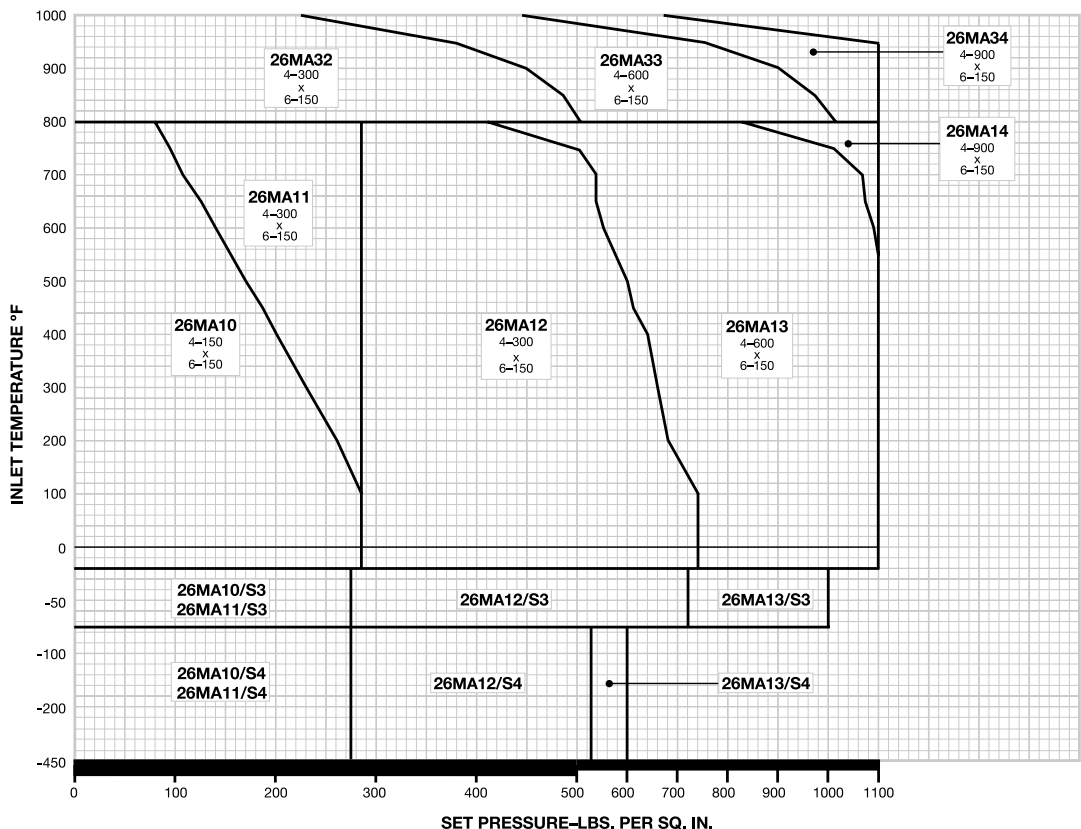

General Notes:

- The type numbers shown on the Selection Chart indicate conventional valves. For BalanSeal, O-ring construction, balanced piston design and other valve options, see the type numbering system on pages 10 and 11.
- Outlet pressure for temperatures above 100° F should not exceed the rating in ANSI B16.5.
- For applications above 1000° F, consult the Farris Factory.

N Orifice

U.S. Customary Units, API Area: 4.34 sq. in., Actual Area: 4.822 sq. in.															
Type Number		Valve Size	ANSI Flange Class		Maximum Set Pressure, psig						Back Pressure Limit psig @ 100°F		Material		Inlet Temp. Range
Conventional	BalanSeal	Inlet Outlet	Inlet RF or RJ	Outlet RF	-450°F -76°F	-75°F -21°F	-20°F +100°F	450°F	800°F	1000°F	Conventional Type	BalanSeal Type	Body & Bonnet	Spring	
26NA10	26NB10	4 x 6	150#	150#			285	185	80		285	80	Carbon Steel	Chrome Alloy	-20°F to 800°F
26NA11	26NB11	4 x 6	300#	150#			285	285	285		285	80			
26NA12	26NB12	4 x 6	300#	150#			740	615	410		285	160			
26NA13	26NB13	4 x 6	600#	150#			1000	1000	825		285	160			
26NA14	26NB14	4 x 6	900#	150#			1000	1000	1000		285	160			
26NA32	26NB32	4 x 6	300#	150#					510	225	285	160	Chrome Moly Steel	High Temp. Alloy	801°F to 1000°F
26NA33	26NB33	4 x 6	600#	150#					1000	445	285	160			
26NA34	26NB34	4 x 6	900#	150#					1000	670	285	160			
26NA10/S3	26NB10/S3	4 x 6	150#	150#		275					275	80	316 St. St.	Chrome Alloy Nickel Plated	-21°F to -75°F
26NA11/S3	26NB11/S3	4 x 6	300#	150#		275					275	80			
26NA12/S3	26NB12/S3	4 x 6	300#	150#		720					275	160			
26NA13/S3	26NB13/S3	4 x 6	600#	150#		1000					275	160			
26NA10/S4	26NB10/S4	4 x 6	150#	150#	275						275	80	316 St. St.	316 St. St.	-76°F to -450°F
26NA11/S4	26NB11/S4	4 x 6	300#	150#	275						275	80			
26NA12/S4	26NB12/S4	4 x 6	300#	150#	450						275	160			
26NA13/S4	26NB13/S4	4 x 6	600#	150#	500						275	160			

Selection Chart

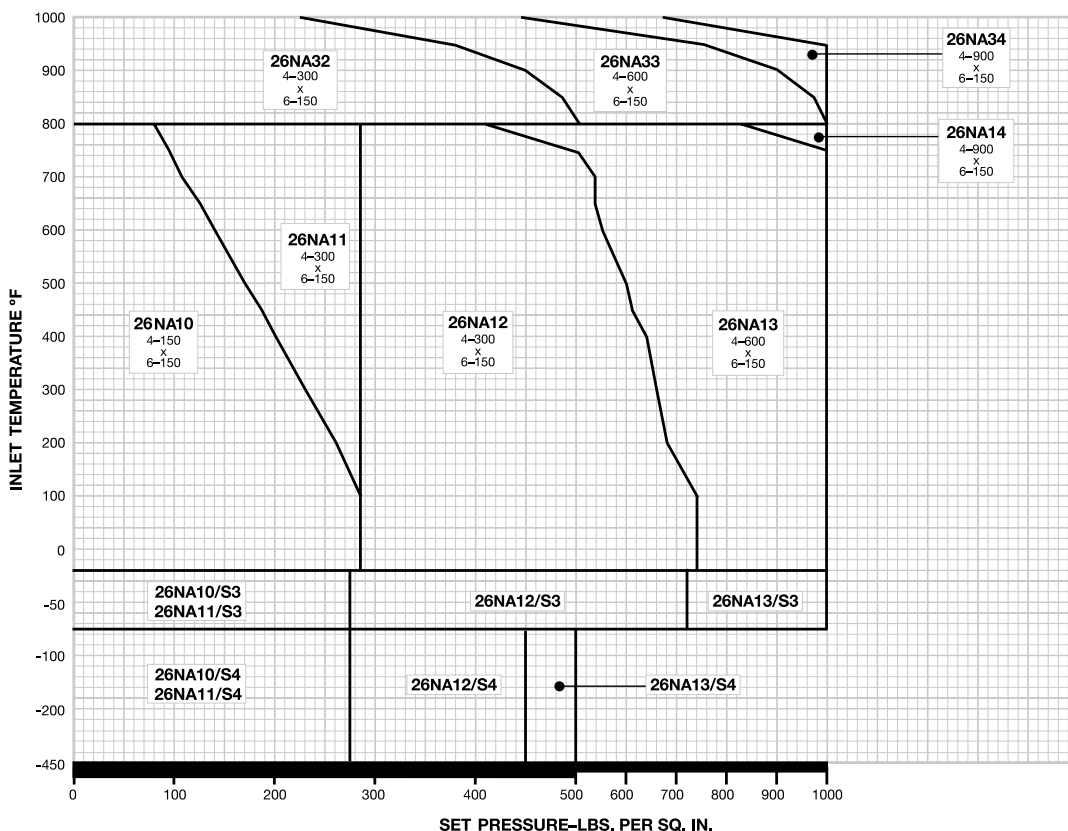

General Notes:

- The type numbers shown on the Selection Chart indicate conventional valves. For BalanSeal, O-ring construction, balanced piston design and other valve options, see the type numbering system on pages 10 and 11.
- Outlet pressure for temperatures above 100° F should not exceed the rating in ANSI B16.5.
- For applications above 1000° F, consult the Farris Factory.



P Orifice

U.S. Customary Units, API Area: 6.38 sq. in., Actual Area: 7.087 sq. in.															
Type Number		Valve Size	ANSI Flange Class		Maximum Set Pressure, psig						Back Pressure Limit psig @ 100°F		Material		Inlet Temp. Range
Conventional	BalanSeal	Inlet Outlet	Inlet RF or RJ	Outlet RF	-450°F -76°F	-75°F -21°F	-20°F +100°F	450°F	800°F	1000°F	Conventional Type	BalanSeal Type	Body & Bonnet	Spring	
26PA10	26PB10	4 x 6	150#	150#			285	185	80		285	80	Carbon Steel	Chrome Alloy	-20°F to 800°F
26PA11	26PB11	4 x 6	300#	150#			285	285	285		285	80			
26PA12	26PB12	4 x 6	300#	150#			525	525	410		285	150			
26PA13	26PB13	4 x 6	600#	150#			1000	1000	825		285	150			
26PA14	26PB14	4 x 6	900#	150#			1000	1000	1000		285	150			
26PA32	26PB32	4 x 6	300#	150#				510	225		285	150	Chrome Moly Steel	High Temp. Alloy	801°F to 1000°F
26PA33	26PB33	4 x 6	600#	150#				1000	445		285	150			
26PA34	26PB34	4 x 6	900#	150#				1000	670		285	150			
26PA10/S3	26PB10/S3	4 x 6	150#	150#		275					275	80	316 St. St.	Chrome Alloy Nickel Plated	-21°F to -75°F
26PA11/S3	26PB11/S3	4 x 6	300#	150#		275					275	80			
26PA12/S3	26PB12/S3	4 x 6	300#	150#		720					275	150			
26PA13/S3	26PB13/S3	4 x 6	600#	150#		1000					275	150			
26PA10/S4	26PB10/S4	4 x 6	150#	150#	175						175	80	316 St. St.	316 St. St.	-76°F to -450°F
26PA11/S4	26PB11/S4	4 x 6	300#	150#	175						175	80			
26PA12/S4	26PB12/S4	4 x 6	300#	150#	300						275	150			
26PA13/S4	26PB13/S4	4 x 6	600#	150#	480						275	150			

Selection Chart

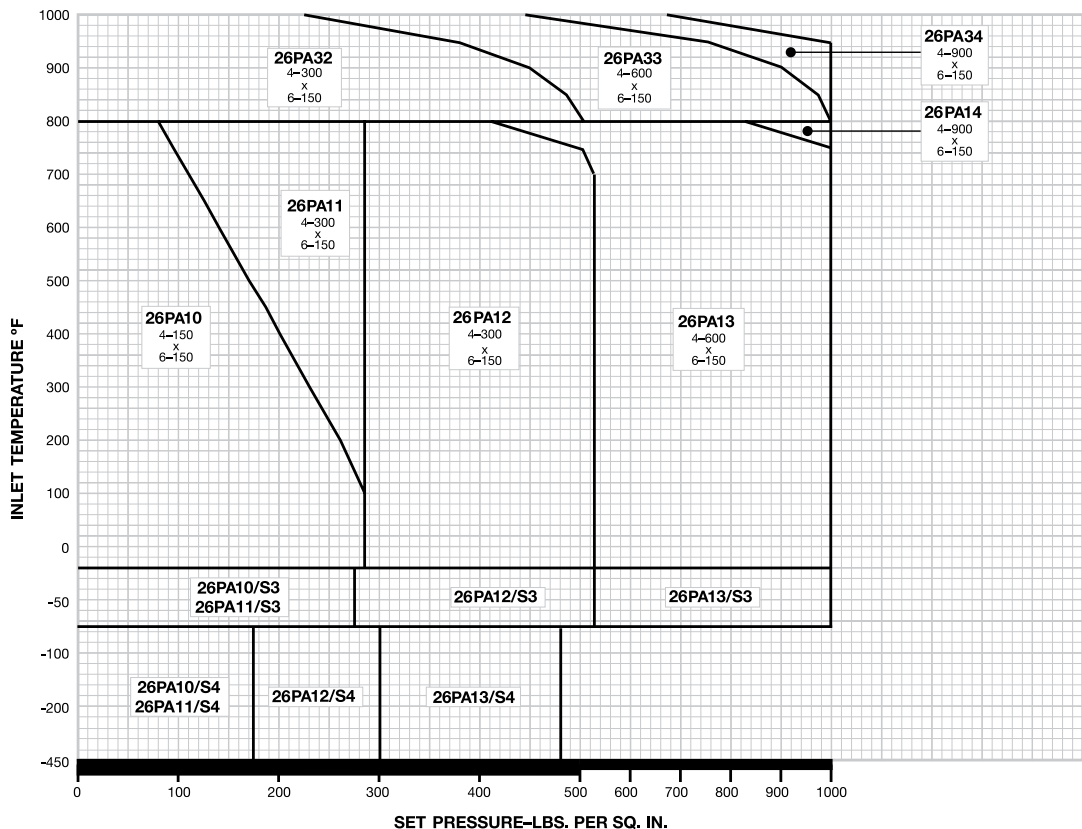

General Notes:

1. The type numbers shown on the Selection Chart indicate conventional valves. For BalanSeal, O-ring construction, balanced piston design and other valve options, see the type numbering system on pages 10 and 11.
2. Outlet pressure for temperatures above 100° F should not exceed the rating in ANSI B16.5.
3. For applications above 1000° F, consult the Farris Factory.

Q Orifice

U.S. Customary Units, API Area: 11.05 sq. in., Actual Area: 12.27 sq. in.															
Type Number		Valve Size	ANSI Flange Class		Maximum Set Pressure, psig						Back Pressure Limit psig @ 100°F		Material		Inlet Temp. Range
Conventional	BalanSeal	Inlet Outlet	Inlet RF or RJ	Outlet RF	-450°F -76°F	-75°F -21°F	-20°F +100°F	450°F	800°F	1000°F	Conventional Type	Balan-Seal Type	Body & Bonnet	Spring	
26QA10	26QB10	6 x 8	150#	150#			165	165	80		115	70	Carbon Steel	Chrome Alloy	-20°F to 800°F
26QA11	26QB11	6 x 8	300#	150#			165	165	165		115	70			
26QA12	26QB12	6 x 8	300#	150#			300	300	300		115	115			
26QA13	26QB13	6 x 8	600#	150#			600	600	600		115	115			
H26QA13	H26QB13	6 x 8	600#	150#			900	900	825		285	200			
26QA32	26QB32	6 x 8	300#	150#				165	165		115	70	Chrome Moly Steel	High Temp. Alloy	801°F to 1000°F
26QA33	26QB33	6 x 8	600#	150#				600	445		115	70			
H26QA33	H26QB33	6 x 8	600#	150#				900	445		285	200			
26QA10/S3	26QB10/S3	6 x 8	150#	150#		165					115	70	316 St. St.	Chrome Alloy Nickel Plated	-21°F to -75°F
26QA11/S3	26QB11/S3	6 x 8	300#	150#		165					115	70			
26QA12/S3	26QB12/S3	6 x 8	300#	150#		300					115	115			
26QA13/S3	26QB13/S3	6 x 8	600#	150#		600					115	115			
26QA10/S4	26QB10/S4	6 x 8	150#	150#	165						115	70	316 St. St.	316 St. St.	-76°F to -450°F
26QA11/S4	26QB11/S4	6 x 8	300#	150#	165						115	70			
26QA12/S4	26QB12/S4	6 x 8	300#	150#	250						115	115			
26QA13/S4	26QB13/S4	6 x 8	600#	150#	300						115	115			

Selection Chart

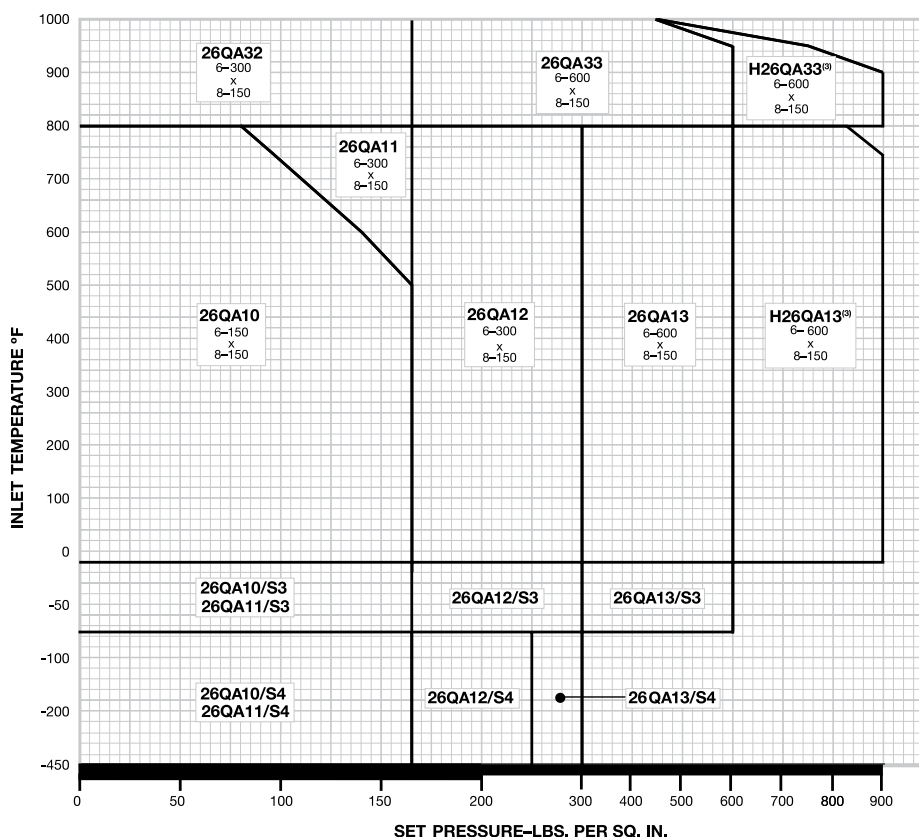

General Notes:

- The type numbers shown on the Selection Chart indicate conventional valves. For BalanSeal, O-ring construction, balanced piston design and other valve options, see the type numbering system on pages 10 and 11.
- Outlet pressure for temperatures above 100° F should not exceed the rating in ANSI B16.5.
- For applications above 1000° F, consult the Farris Factory.



R Orifice

U.S. Customary Units, API Area: 16.00 sq. in., Actual Area: 17.78 sq. in.															
Type Number		Valve Size	ANSI Flange Class		Maximum Set Pressure, psig						Back Pressure Limit psig @ 100°F		Material		Inlet Temp. Range
Conventional	BalanSeal	Inlet Outlet	Inlet RF or RJ	Outlet RF	-450°F -76°F	-75°F -21°F	-20°F +100°F	450°F	800°F	1000°F	Conventional Type	Balan-Seal Type	Body & Bonnet	Spring	
26RA10	26RB10	6 x 8	150#	150#			100	100	80		60	60	Carbon Steel	Chrome Alloy	-20°F to 800°F
26RA11	26RB11	6 x 8	300#	150#			100	100	100		60	60			
26RA12	26RB12	6 x 10	300#	150#			230	230	230		100	100			
26RA13	26RB13	6 x 10	600#	150#			300	300	300		100	100			
H26RA13	H26RB13	6 x 10	600#	150#			600	600	600		285	200			
26RA32	26RB32	6 x 8	300#	150#					100	100	60	60	Chrome Moly Steel	High Temp. Alloy	801°F to 1000°F
26RA33	26RB33	6 x 10	600#	150#				300	300	100	100	100			
H26RA33	H26RB33	6 x 10	600#	150#				600	445	285	200				
26RA10/S3	26RB10/S3	6 x 8	150#	150#		100					60	60	316 St. St.	Chrome Alloy Nickel Plated	-21°F to -75°F
26RA11/S3	26RB11/S3	6 x 8	300#	150#		100					60	60			
26RA12/S3	26RB12/S3	6 x 10	300#	150#		230					100	100			
26RA13/S3	26RB13/S3	6 x 10	600#	150#		300					100	100			
26RA10/S4	26RB10/S4	6 x 8	150#	150#	55						55	55	316 St. St.	316 St. St.	-76°F to -450°F
26RA11/S4	26RB11/S4	6 x 8	300#	150#	55						55	55			
26RA12/S4	26RB12/S4	6 x 10	300#	150#	150						100	100			
26RA13/S4	26RB13/S4	6 x 10	600#	150#	200						100	100			

Selection Chart

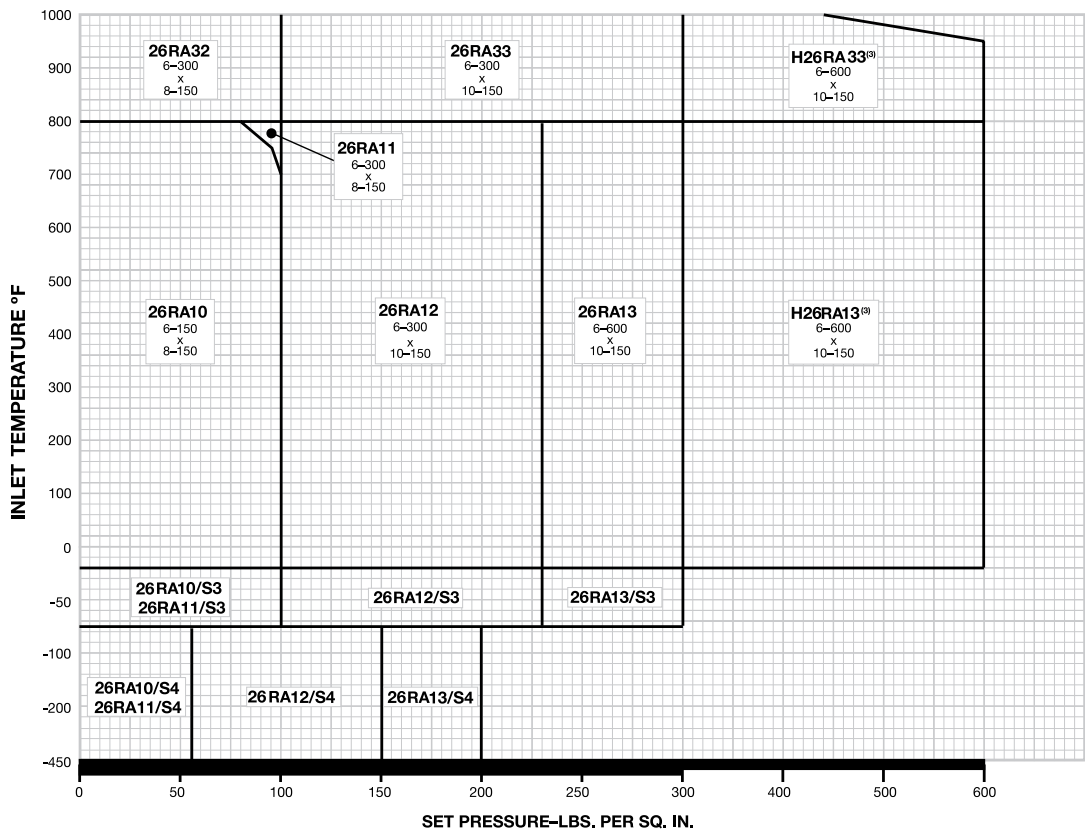

General Notes:

1. The type numbers shown on the Selection Chart indicate conventional valves. For BalanSeal, O-ring construction, balanced piston design and other valve options, see the type numbering system on pages 10 and 11.
2. Outlet pressure for temperatures above 100° F should not exceed the rating in ANSI B16.5.
3. For applications above 1000° F, consult the Farris Factory.

T Orifice

U.S. Customary Units, API Area: 26.00 sq. in., Actual Area: 28.94 sq. in.															
Type Number		Valve Size	ANSI Flange Class		Maximum Set Pressure, psig						Back Pressure Limit psig @ 100°F		Material		Inlet Temp. Range
Conventional	BalanSeal	Inlet Outlet	Inlet RF or RJ	Outlet RF	-450°F -76°F	-75°F -21°F	-20°F +100°F	450°F	800°F	1000°F	Conventional Type	BalanSeal Type	Body & Bonnet	Spring	
26TA10	26TB10	8 x 10	150#	150#			65	65	65		30	30	Carbon Steel	Chrome Alloy	-20°F to 800°F
26TA11	26TB11	8 x 10	300#	150#			65	65	65		30	30			
26TA12	26TB12	8 x 10	300#	150#			120	120	120		60	60			
H26TA12	H26TB12	8 x 10	300#	150#			300	300	300		100	100			
26TA32	26TB32	8 x 10	300#	150#					120	120	60	60	Chrome Moly St.	High Temp. Alloy	801°F to 1000°F
H26TA32	H26TB32	8 x 10	300#	150#					300	225	100	100			
26TA10/S3	26TB10/S3	8 x 10	150#	150#		65					30	30	316 St. St.	Chrome Alloy Nickel Pitted	-21°F to -75°F
26TA11/S3	26TB11/S3	8 x 10	300#	150#		65					30	30			
26TA12/S3	26TB12/S3	8 x 10	300#	150#		120					60	60			
26TA10/S4	26TB10/S4	8 x 10	150#	150#	50						30	30	316 St. St.	316 St. St.	-76°F to -450°F
26TA11/S4	26TB11/S4	8 x 10	300#	150#	50						30	30			
26TA12/S4	26TB12/S4	8 x 10	300#	150#	65						60	60			

Selection Chart

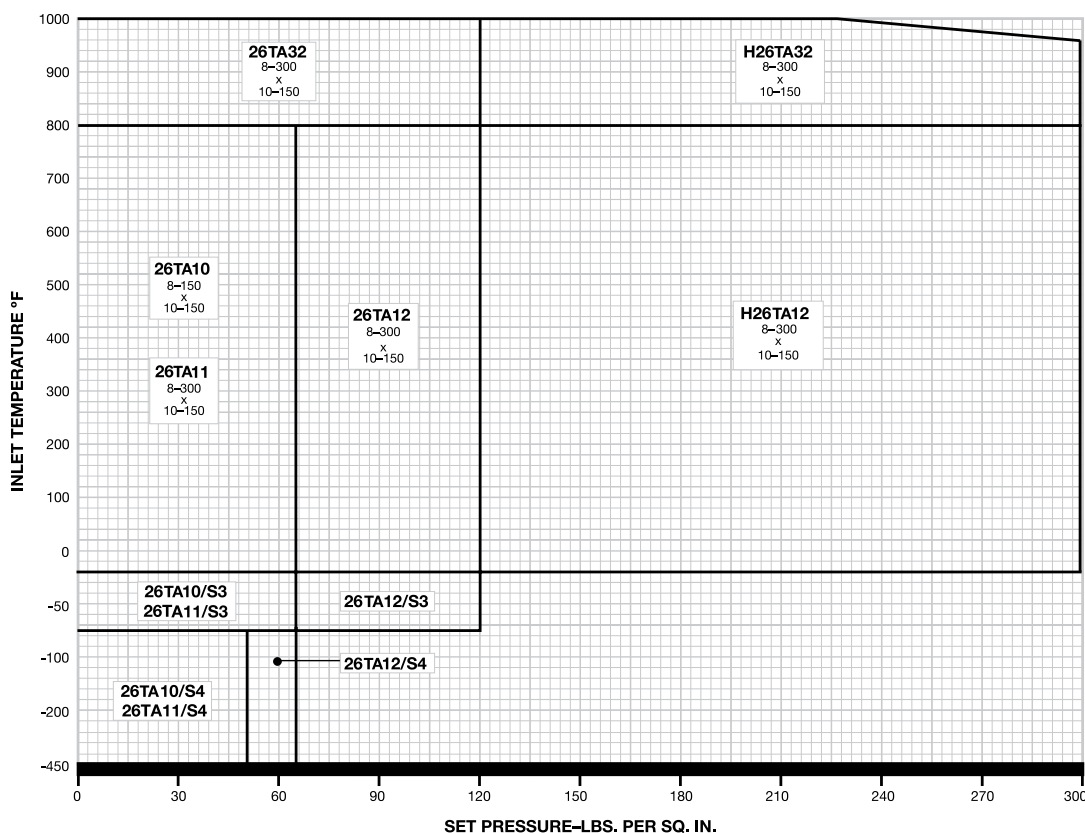

General Notes:

1. The type numbers shown on the Selection Chart indicate conventional valves. For BalanSeal, O-ring construction, balanced piston design and other valve options, see the type numbering system on pages 10 and 11.
2. Outlet pressure for temperatures above 100° F should not exceed the rating in ANSI B16.5.
3. For applications above 1000° F, consult the Farris Factory.

Former API Standard Sizes

API Standard 526, Flanged Steel Pressure Relief Valves, was revised to eliminate the use of 2-1/2" size connections and to use 3" connections instead. The following is a summary of the old type numbers previously offered. The original type numbers with 2-1/2" connections are still available for replacement of existing valves.

Orifice	Type Number		Valve Size Inlet x Outlet	ANSI Flange Class		Dimensions, Inches					Approx. Weight
	Air, Steam, & Vapor	Liquid		Inlet	Outlet	A	B	C	E	F	
D	26DA16	26DA16L	1 1/2 x 2 1/2	2500#	300#	22 3/4	6 1/2	5 1/2	11/16	2 7/16	80
E	26EA16	26EA16L	1 1/2 x 2 1/2	2500#	300#	22 3/4	6 1/2	5 1/2	11/16	2 7/16	80
F	26FA14	26FA14L	1 1/2 x 2 1/2	900#	300#	22 3/4	6	4 7/8	11/16	1 15/16	70
	26FA15	26FA15L	1 1/2 x 2 1/2	1500#	300#	22 3/4	6	4 7/8	11/16	1 15/16	70
	26FA16	26FA16L	1 1/2 x 2 1/2	2500#	300#	22 3/4	6 1/2	5 1/2	11/16	2 7/16	80
G	26GA10	26GA10L	1 1/2 x 2 1/2	150#	150#	18 5/8	4 3/4	4 7/8	11/16	1 1/4	50
	26GA11	26GA11L	1 1/2 x 2 1/2	300#	150#	18 5/8	4 3/4	4 7/8	11/16	1 9/16	50
	26GA12	26GA12L	1 1/2 x 2 1/2	300#	150#	22 1/4	6	4 7/8	11/16	1 9/16	60
	26GA13	26GA13L	1 1/2 x 2 1/2	600#	150#	22 1/4	6	4 7/8	11/16	1 9/16	60
	26GA14	26GA14L	1 1/2 x 2 1/2	900#	300#	23 3/4	6	4 7/8	11/16	1 15/16	70
J	26JA12	26JA12L	2 1/2 x 4	300#	150#	24 3/8	5 5/8	5 3/8	11/16	1 13/16	150
	26JA13	26JA13L	2 1/2 x 4	600#	150#	24 3/8	5 5/8	5 3/8	11/16	1 13/16	150
	26JA32	26JA32L	2 1/2 x 4	300#	150#	24 3/8	5 5/8	5 3/8	11/16	1 13/16	150
	26JA33	26JA33L	2 1/2 x 4	600#	150#	24 3/8	6 3/4	6 1/8	11/16	1 13/16	150
	26JA34	26JA34L	2 1/2 x 4	900#	150#	33 1/8	7 1/8	7 1/4	11/16	2 5/16	170
K	26KA34	26KA34L	3 x 4	900#	150#	32 3/8	7 1/8	7 1/4	11/16	2 3/16	175

Optional Construction	7th Digit Designation	
	Air, Steam & Vapor	Liquids
Heat Transfer Fluid Service	F	G
Exposed Spring	C	N/A*
*Not applicable		

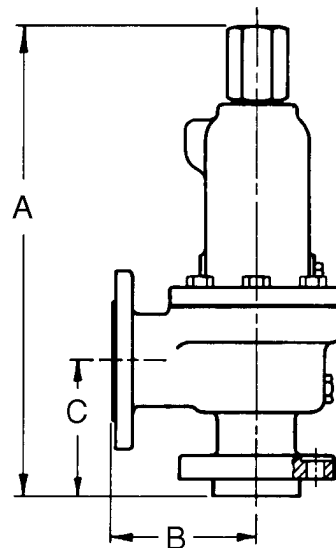

General Notes:

1. Pressure and temperature limitations are the same as the comparable orifice and flange classes shown in main Selection Tables.
2. The sizes and flange connections are also available in their respective high temperature type numbers. Example: 26DA36-120.
3. All standard constructions and accessories are available including balanced bellows, O-ring seats, test levers, etc.
4. Additional optional constructions may be specified by changing the seventh digit of the type number. See following table.

Air Capacities – 2600 Series: 10% Overpressure, API

ASME Pressure Vessel Code (UV), Capacities in Standard Cubic Feet Per Minute at 60°F														
Set Pressure (psig)	Orifice Letter Designation & Areas, Sq. Inches													
Areas	D	E	F	G	H	J	K	L	M	N	P	Q	R	T
API	0.110	0.196	0.307	0.503	0.785	1.287	1.838	2.853	3.60	4.34	6.38	11.05	16.0	26.0
Actual	0.150	0.225	0.371	0.559	0.873	1.43	2.042	3.170	4.000	4.822	7.087	12.27	17.78	28.94
15	77	115	190	287	448	735	1050	1630	2057	2479	3644	6310	9144	14884
20	88	133	219	331	517	847	1210	1879	2371	2859	4202	7275	10542	17159
30	112	168	278	419	654	1072	1531	2378	3000	3617	5316	9205	13339	21711
40	138	207	342	516	805	1320	1885	2926	3692	4451	6542	11328	16415	26718
50	164	246	406	612	957	1567	2238	3475	4384	5286	7769	13450	19491	31725
60	190	285	470	709	1108	1815	2591	4023	5076	6120	8995	15573	22567	36732
70	216	324	535	806	1259	2062	2945	4571	5769	6954	10221	17696	25643	41738
80	242	363	599	902	1410	2309	3298	5120	6461	7788	11447	19819	28719	46745
90	268	402	663	999	1561	2557	3651	5668	7153	8623	12673	21942	31795	51752
100	294	441	727	1096	1712	2804	4004	6217	7845	9457	13899	24064	34871	56759
150	423	635	1048	1579	2467	4041	5771	8959	11305	13628	20030	34678	50251	81793
200	553	830	1369	2063	3222	5278	7537	11701	14765	17799	26160	45293	65632	106827
250	683	1025	1690	2547	3977	6515	9304	14443	18225	21970	32291	55907	81012	131862
300	813	1219	2011	3030	4732	7752	11070	17185	21685	26142	38421	66521	96393	156896
350	942	1414	2332	3514	5488	8989	12836	19928	25145	30313	44552	77135	111773	
400	1072	1609	2653	3997	6243	10226	14603	22670	28606	34484	50682	87749	127154	
450	1202	1803	2974	4481	6998	11463	16369	25412	32066	38655	56813	98363	142534	
500	1332	1998	3295	4964	7753	12700	18136	28154	35526	42827	62943	108977	157914	
550	1461	2192	3616	5448	8508	13937	19902	30896	38986	46998	69074	119591	173295	
600	1591	2387	3936	5931	9263	15174	21669	33639	42446	51169	75204	130205	188675	
650	1721	2582	4257	6415	10019	16411	23435	36381	45906	55340	81335	140819		
700	1851	2776	4578	6899	10774	17648	25201	39123	49367	59511	87466	151433		
750	1981	2971	4899	7382	11529	18885	26968	41865	52827	63683	93596	162047		
800	2110	3166	5220	7866	12284	20122	28734	44607	56287	67854	99727	172661		
850	2240	3360	5541	8349	13039	21359	30501	47349	59747	72025	105857	183275		
900	2370	3555	5862	8833	13795	22596	32267	50092	63207	76196	111988	193889		
950	2500	3750	6183	9316	14550	23833	34033	52834	66667	80368	118118			
1000	2629	3944	6504	9800	15305	25070	35800	55576	70127	84539	124249			
1050	2759	4139	6825	10283	16060	26307	37566	58318	73588					
1100	2889	4333	7146	10767	16815	27544	39333	61060	77048					
1150	3019	4528	7467	11251	17570	28781	41099	63802						
1200	3148	4723	7788	11734	18326	30018	42865	66545						
1250	3278	4917	8109	12218	19081	31255	44632	69287						
1300	3408	5112	8429	12701	19836	32492	46398	72029						
1350	3538	5307	8750	13185	20591	33729	48165	74771						
1400	3667	5501	9071	13668	21346	34966	49931	77513						
1450	3797	5696	9392	14152	22102	36203	51698	80256						
1500	3927	5891	9713	14635	22857	37440	53464	82998						
1550	4057	6085	10034	15119	23612	38677	55230							
1600	4186	6280	10355	15603	24367	39914	56997							
1650	4316	6474	10676	16086	25122	41151	58763							
1700	4446	6669	10997	16570	25877	42388	60530							
1750	4576	6864	11318	17053	26633	43625	62296							
1800	4705	7058	11639	17537	27388	44862	64062							
1850	4835	7253	11960	18020	28143	46099	65829							
1900	4965	7448	12281	18504	28898	47336	67595							
2000	5224	7837	12922	19471	30409	49810	71128							
2100	5484	8226	13564	20438	31919	52284	74661							
2200	5743	8615	14206	21405	33429	54758	78194							
2300	6003	9005	14848	22372	34940	57232								
2400	6262	9394	15490	23339	36450	59706								
2500	6522	9783	16132	24307	37960	62180								
2600	6781	10172	16774	25274	39471	64654								
2700	7041	10562	17415	26241	40981	67128								
2800	7301	10951	18057	27208										
2900	7560	11340	18699	28175										
3000	7820	11730	19341	29142										
3500	9117	13676	22550	33978										
3700	9636	14454	23834	35912										
4000	10415	15622	25760											
4500	11712	17569	28969											
5000	13010	19515	32178											
5500	14307	21461												
6000	15605	23408												

General Notes:
 1. Above capacities should also be used for 2600L series when used in air service.
 2. Capacities at 30 psig and below are based on 3 PSI overpressure.
 3. For sizing purposes the effective coefficient of discharge K_d for air, gas, and steam is 0.953 when sizing using the API effective areas. When sizing using the ASME actual areas, the certified coefficient of discharge K for air, gas, and steam service is 0.858.



Steam Capacities – 2600 Series: 10% Overpressure, API

ASME Pressure Vessel Code (UV), Capacities in Pounds Per Hour at Saturation Temperature														
Set Pressure (psig)	Orifice Letter Designation & Areas, Sq. Inches													
Areas	D	E	F	G	H	J	K	L	M	N	P	Q	R	T
API	0.110	0.196	0.307	0.503	0.785	1.287	1.838	2.853	3.60	4.34	6.38	11.05	16.0	26.0
Actual	0.150	0.225	0.371	0.559	0.873	1.43	2.042	3.170	4.000	4.822	7.087	12.27	17.78	28.94
15	216	325	536	807	1261	2066	2950	4580	5779	6967	10240	17729	25690	41815
20	249	374	618	931	1454	2382	3401	5280	6663	8032	11805	20439	29618	48209
30	316	474	781	1178	1840	3014	4303	6681	8430	10163	14937	25861	37475	60997
40	389	583	962	1449	2264	3709	5296	8222	10375	12507	18382	31825	46117	75063
50	461	692	1142	1721	2688	4404	6289	9763	12319	14850	21826	37789	54759	89130
60	534	802	1322	1993	3113	5099	7281	11303	14263	17194	25271	43753	63401	103196
70	607	911	1503	2265	3537	5794	8274	12844	16207	19538	28716	49717	72043	117263
80	680	1021	1683	2536	3961	6489	9266	14385	18152	21882	32160	55681	80685	131329
90	753	1130	1863	2808	4386	7184	10259	15926	20096	24226	35605	61645	89327	145396
100	826	1239	2044	3080	4810	7879	11251	17467	22040	26569	39050	67609	97969	159462
150	1191	1786	2945	4438	6931	11354	16214	25171	31761	38288	56273	97428	141180	229795
200	1555	2333	3847	5797	9053	14830	21176	32875	41482	50007	73497	127248	184390	300127
250	1920	2880	4749	7155	11175	18305	26139	40579	51203	61726	90720	157067	227601	370460
300	2284	3427	5650	8514	13296	21780	31102	48283	60925	73445	107943	186887	270811	440792
350	2649	3973	6552	9872	15418	25256	36064	55987	70646	85163	125167	216707	314022	
400	3013	4520	7454	11231	17540	28731	41027	63691	80367	96882	142390	246526	357232	
450	3378	5067	8355	12589	19661	32206	45990	71395	90088	108601	159614	276346	400443	
500	3742	5614	9257	13948	21783	35681	50952	79099	99809	120320	176837	306165	443653	
550	4107	6161	10158	15306	23905	39157	55915	86803	109530	132039	194061	335985	486864	
600	4471	6707	11060	16665	26026	42632	60878	94507	119251	143758	211284	365805	530074	
650	4836	7254	11962	18023	28148	46107	65840	102211	128973	155476	228507	395624		
700	5201	7801	12863	19382	30269	49583	70803	109915	138694	167195	245731	425444		
750	5565	8348	13765	20741	32391	53058	75766	117619	148415	178914	262954	455263		
800	5930	8895	14667	22099	34513	56533	80728	125323	158136	190633	280178	485083		
850	6294	9441	15568	23458	36634	60009	85691	133027	167857	202352	297401	514903		
900	6659	9988	16470	24816	38756	63484	90653	140731	177578	214071	314625	544722		
950	7023	10535	17372	26175	40878	66959	95616	148435	187299	225789	331848			
1000	7388	11082	18273	27533	42999	70435	100579	156139	197020	237508	349071			
1050	7752	11629	19175	28892	45121	73910	105541	163843	206742					
1100	8117	12176	20076	30250	47243	77385	110504	171547	216463					
1150	8481	12722	20978	31609	49364	80860	115467	179251						
1200	8846	13269	21880	32967	51486	84336	120429	186955						
1250	9211	13816	22781	34326	53608	87811	125392	194659						
1300	9575	14363	23683	35684	55729	91286	130355	202363						
1350	9940	14910	24585	37043	57851	94762	135317	210067						
1400	10304	15456	25486	38401	59972	98237	140280	217771						
1450	10669	16003	26388	39760	62094	101712	145242	225475						
1500	11088	16633	27426	41324	64537	105714	150956	234345						
1550	11489	17234	28417	42817	66868	109532	156409							
1600	11891	17838	29413	44318	69212	113372	161891							
1650	12309	18464	30444	45872	71640	117348	167569							
1700	12728	19093	31483	47438	74083	121352	173287							
1750	13152	19728	32529	49013	76545	125383	179043							
1800	13564	20347	33549	50551	78947	129316	184661							
1850	14006	21010	34643	52197	81518	133530	190677							
1900	14438	21657	35711	53807	84031	137645	196553							
2000	15325	22987	37903	57111	89191	146098	208625							
2100	16240	24360	40167	60522	94517	154823	221084							
2200	17202	25803	42546	64107	100118	163996	234181							
2300	18182	27272	44970	67758	105819	173335								
2400	19214	28821	47523	71605	111826	183175								
2500	20285	30427	50171	75596	118059	193386								
2600	21416	32124	52970	79811	124643	204168								
2700	22631	33947	55975	84339	131714	215753								
2800	23916	35874	59154	89129										
2900	25318	37978	62622	94355										

General Notes:
 1. Above capacities should also be used for 2600L series when used in steam service.
 2. Capacities at 30 psig and below are based on 3 PSI overpressure.
 3. For sizing purposes the effective coefficient of discharge K_v for air, gas, and steam is 0.953 when sizing using the API effective areas. When sizing using the ASME actual areas, the certified coefficient of discharge K for air, gas, and steam service is 0.858.

Water Capacities – 2600 Series: 10% Overpressure, API

ASME Pressure Vessel Code (UV), Capacities in Gallons Per Minute at 70°F														
Set Pressure (psig)	Orifice Letter Designation & Areas, Sq. Inches													
Areas	D	E	F	G	H	J	K	L	M	N	P	Q	R	T
API	0.110	0.196	0.307	0.503	0.785	1.287	1.838	2.853	3.600	4.34	6.38	11.05	16.0	26.0
Actual	0.150	0.225	0.371	0.559	0.873	1.43	2.042	3.170	4.000	4.822	7.087	12.27	17.78	28.94
15	16	24	39	59	92	150	214	333	420	507	745	1289	1868	3041
20	18	27	44	66	104	170	242	376	475	573	842	1457	2112	3438
30	21	32	53	80	124	204	290	451	569	686	1008	1746	2530	4118
40	25	37	61	92	143	235	335	521	657	792	1164	2016	2921	4756
50	28	41	68	103	160	263	375	582	734	886	1302	2254	3266	5317
60	30	45	75	112	176	288	411	638	805	970	1426	2469	3578	5825
70	33	49	81	122	189	311	443	689	869	1048	1540	2667	3865	6292
80	35	52	86	130	203	332	474	736	929	1120	1647	2851	4132	6726
90	37	55	91	137	215	352	503	781	986	1188	1747	3024	4382	7134
100	39	58	96	145	227	372	530	823	1039	1252	1841	3188	4620	7520
150	48	72	118	177	278	455	649	1008	1272	1534	2255	3904	5658	9210
200	55	83	136	205	320	525	750	1164	1469	1771	2604	4508	6533	10635
250	62	92	152	229	358	587	838	1302	1643	1981	2911	5041	7304	11890
300	67	101	167	252	392	644	919	1426	1800	2170	3189	5522	8002	13025
350	73	109	180	271	424	695	992	1541	1944	2344	3445	5964	8643	
400	78	117	193	290	453	743	1061	1647	2078	2505	3683	6376	9240	
450	83	124	204	308	481	788	1125	1747	2204	2657	3906	6763	9800	
500	87	131	215	325	507	831	1186	1841	2324	2801	4117	7129	10330	
550	91	137	226	341	531	871	1244	1931	2437	2938	4318	7477	10834	
600	95	143	236	356	555	910	1299	2017	2545	3069	4510	7809	11316	
650	99	149	245	370	578	947	1352	2100	2649	3194	4694	8128		
700	103	154	255	384	600	983	1403	2179	2749	3315	4872	8435		
750	107	160	264	398	621	1018	1453	2255	2846	3431	5043	8731		
800	110	165	272	411	641	1051	1500	2329	2939	3543	5208	9017		
850	114	170	281	423	661	1083	1546	2401	3030	3653	5368	9295		
900	117	175	289	436	680	1115	1591	2471	3118	3758	5524	9564		
950	120	180	297	448	699	1145	1635	2538	3203	3861	5675			
1000	123	185	304	459	717	1175	1677	2604	3286	3962	5823			
1050	126	189	312	470	735	1204	1719	2669	3367					
1100	129	194	319	482	752	1232	1759	2731	3447					
1150	132	198	326	492	769	1260	1799	2793						
1200	135	202	333	503	785	1287	1838	2853						
1250	137	206	340	513	802	1313	1875	2912						
1300	140	210	347	524	817	1340	1913	2969						
1350	143	214	354	533	833	1365	1949	3026						
1400	146	218	360	543	848	1390	1985	3082						
1450	148	222	367	553	863	1414	2020	3136						
1500	151	226	373	562	878	1439	2055	3190						
1550	153	230	379	571	893	1462	2088							
1600	155	233	385	581	907	1486	2122							
1650	158	237	391	590	921	1509	2155							
1700	160	241	397	598	935	1532	2187							
1750	163	244	403	607	948	1554	2219							
1800	165	248	409	616	962	1576	2251							
1850	167	251	414	624	975	1598	2282							
1900	169	254	420	633	988	1619	2312							
2000	174	261	431	649	1014	1661	2372							
2100	178	267	441	665	1039	1702	2431							
2200	182	274	452	681	1063	1742	2488							
2300	186	280	462	696	1087	1782								
2400	190	286	472	711	1111	1820								
2500	194	292	482	726	1134	1857								
2600	198	298	491	740	1156	1894								
2700	202	303	500	754	1178	1930								
2800	206	309	510	768										
2900	209	314	519	782										
3000	213	320	528	795										
3500	230	345	570	859										
3700	237	355	586	883										
4000	246	369	609											
4500	261	392	646											
5000	275	413	681											
5500	289	433												
6000	301	452												

General Notes:
 1. Capacities at 30 psig and below are based on 3 PSI overpressure.
 2. For sizing purposes the effective coefficient of discharge K_d for liquids is 0.724 when sizing using the API effective areas. When sizing using the ASME actual areas, the certified coefficient of discharge K for water is 0.652.



Water Capacities – 2600 Series: 25% Overpressure

Non-Code, Capacities in Gallons Per Minute at 70 °F														
Set Pressure (psig)	Orifice Letter Designation & Areas, Sq. Inches													
Areas	D	E	F	G	H	J	K	L	M	N	P	Q	R	T
API	0.110	0.196	0.307	0.503	0.785	1.287	1.838	2.853	3.600	4.34	6.38	11.05	16.0	26.0
Actual	0.150	0.225	0.371	0.559	0.873	1.43	2.042	3.170	4.000	4.822	7.087	12.27	17.78	28.94
15	14	21	35	53	82	136	193	300	379	457	672	1163	1685	2743
20	16	24	40	61	95	156	223	347	438	528	776	1342	1946	3167
30	20	30	49	75	117	192	274	425	536	646	950	1644	2383	3879
40	23	35	57	86	135	221	316	491	619	746	1097	1899	2752	4479
50	26	39	64	97	151	247	353	548	692	834	1226	2123	3076	5007
60	28	42	70	106	165	271	387	601	758	914	1343	2325	3370	5485
70	30	46	76	114	179	293	418	649	819	987	1451	2512	3640	5925
80	33	49	81	122	191	313	447	694	875	1055	1551	2685	3892	6334
90	35	52	86	130	203	332	474	736	929	1119	1645	2848	4128	6718
100	37	55	91	137	214	350	499	776	979	1180	1734	3002	4351	7082
150	45	71	111	168	261	428	611	950	1198	1445	2124	3677	5328	8673
200	52	77	128	193	302	495	706	1097	1384	1669	2452	4246	6153	10015
250	58	92	143	216	337	553	790	1226	1547	1866	2742	4747	6879	11197
300	64	95	157	237	370	606	865	1344	1695	2044	3004	5200	7536	12266
350	69	103	169	256	399	655	934	1451	1831	2208	3244	5617	8139	
400	73	110	181	274	427	700	999	1551	1958	2360	3468	6005	8702	
450	78	116	192	290	453	742	1060	1645	2076	2503	3678	6369	9229	
500	82	123	203	306	477	782	1117	1734	2189	2638	3878	6713	9729	
550	86	129	213	321	501	821	1171	1819	2295	2767	4067	7041	10204	
600	90	135	222	335	523	857	1223	1900	2398	2890	4248	7354	10657	
650	94	140	231	349	544	892	1273	1978	2495	3008	4421	7655		
700	97	146	240	362	565	926	1322	2052	2590	3122	4588	7944		
750	100	151	248	375	585	958	1368	2124	2681	3232	4749	8222		
800	104	156	257	387	604	990	1413	2194	2768	3337	4905	8492		
850	107	160	264	399	623	1020	1456	2262	2854	3440	5056	8753		
900	110	165	272	410	641	1050	1499	2327	2936	3540	5203	9007		
950	113	170	280	422	658	1078	1540	2391	3016	3637	5345			
1000	116	174	287	432	675	1106	1580	2453	3095	3731	5484			
1050	118	178	294	443	692	1133	1619	2513	3171					
1100	122	182	301	454	708	1160	1657	2573	3246					
1150	124	186	307	463	724	1186	1694	2630						
1200	127	191	314	474	740	1212	1730	2687						
1250	129	194	320	483	755	1237	1766	2742						
1300	132	198	327	493	770	1262	1801	2797						
1350	134	202	333	502	784	1285	1835	2850						
1400	137	206	339	512	799	1309	1869	2902						
1450	139	209	345	520	813	1332	1902	2953						
1500	142	213	351	530	827	1355	1935	3004						
1550	144	216	357	538	841	1377	1967							
1600	147	220	363	547	854	1400	1998							
1650	149	223	368	555	867	1421	2029							
1700	151	227	374	564	880	1443	2060							
1750	153	230	379	572	893	1463	2090							
1800	156	233	385	580	906	1484	2120							
1850	157	236	390	588	918	1505	2149							
1900	160	239	395	596	931	1525	2178							
2000	164	246	406	612	955	1564	2234							
2100	168	252	416	627	978	1603	2289							
2200	172	258	425	642	1002	1641	2343							
2300	176	264	435	656	1024	1678								
2400	180	270	444	670	1046	1714								
2500	184	275	454	684	1068	1749								
2600	187	281	463	698	1089	1784								
2700	191	286	471	711	1110	1818								
2800	194	291	480	724										
2900	198	296	488	737										
3000	201	301	497	749										
3500	217	325	537	809										
3700	223	334	552	832										
4000	232	348	574											
4500	246	369	609											
5000	260	389	641											
5500	272	408												
6000	284	426												

General Notes:
 1. Capacities at 30 psig and below are based on 3 PSI overpressure.
 2. For sizing purposes the effective coefficient of discharge K_d for liquids is 0.64 when sizing using the API effective areas. When sizing using the actual areas, the coefficient of discharge K for water is 0.576.

D Orifice

Metric Units, API Area: 71 mm ² , Actual Area: 97 mm ²															
Type Number		Valve Size	ANSI Flange Class		Maximum Set Pressure, barg						Back Pressure Limit barg @ 38°C		Material		Inlet Temp. Range
Conventional	BalanSeal	Inlet Outlet	Inlet RF or RJ	Outlet RF	-268°C -60°C	-59°C -30°C	-29°C +38°C	+232°C	+427°C	+538°C	Conventional Type	Balan-Seal Type	Body & Bonnet	Spring	
26DA10	26DB10	1 x 2	150#	150#			19.6	12.7	5.5		19.6	15.8	Carbon Steel	Chrome Alloy	-29°C to 427°C
26DA11	26DB11	1 x 2	300#	150#			19.6	19.6	19.6		19.6	15.8			
26DA12	26DB12	1 x 2	300#	150#			51.0	42.4	28.2		19.6	15.8			
26DA13	26DB13	1 x 2	600#	150#			102	85.1	56.8		19.6	15.8			
26DA14		1 1/2 x 2	900#	300#			153	127	85.1		41.3	34.5			
26DA15		1 1/2 x 2	1500#	300#			255	212	142		41.3	34.5			
26DA16A		1 1/2 x 3	2500#	300#			413	354	236		51	34.5			
26DA32	26DB32	1 x 2	300#	150#					35.1	15.5	19.6	15.8	Chrome Moly Steel	High Temp. Alloy	428°C to 538°C
26DA33	26DB33	1 x 2	600#	150#					69.9	30.6	19.6	15.8			
26DA34		1 1/2 x 2	900#	300#					105	46.2	41.3	34.5			
26DA35		1 1/2 x 2	1500#	300#					175	76.8	41.3	34.5			
26DA36A		1 1/2 x 3	2500#	300#					291	128	51	34.5			
26DA10/S3	26DB10/S3	1 x 2	150#	150#		18.9					18.9	15.8	316 St. St.	Chrome Alloy Nickel Plated	-30°C to -59°C
26DA11/S3	26DB11/S3	1 x 2	300#	150#		18.9					18.9	15.8			
26DA12/S3	26DB12/S3	1 x 2	300#	150#		49.6					18.9	15.8			
26DA13/S3	26DB13/S3	1 x 2	600#	150#		99.2					18.9	15.8			
26DA14/S3		1 1/2 x 2	900#	300#		149					41.3	34.5			
26DA15/S3		1 1/2 x 2	1500#	300#		248					41.3	34.5			
26DA16A/S3		1 1/2 x 3	2500#	300#		413					49.6	34.5			
26DA10/S4	26DB10/S4	1 x 2	150#	150#	18.9						18.9	15.8	316 St. St.	316 St. St.	-60°C to -268°C
26DA11/S4	26DB11/S4	1 x 2	300#	150#	18.9						18.9	15.8			
26DA12/S4	26DB12/S4	1 x 2	300#	150#	49.6						18.9	15.8			
26DA13/S4	26DB13/S4	1 x 2	600#	150#	99.2						18.9	15.8			
26DA14/S4		1 1/2 x 2	900#	300#	149						41.3	34.5			
26DA15/S4		1 1/2 x 2	1500#	300#	248						41.3	34.5			
26DA16A/S4		1 1/2 x 3	2500#	300#	276						49.6	34.5			

Selection Chart

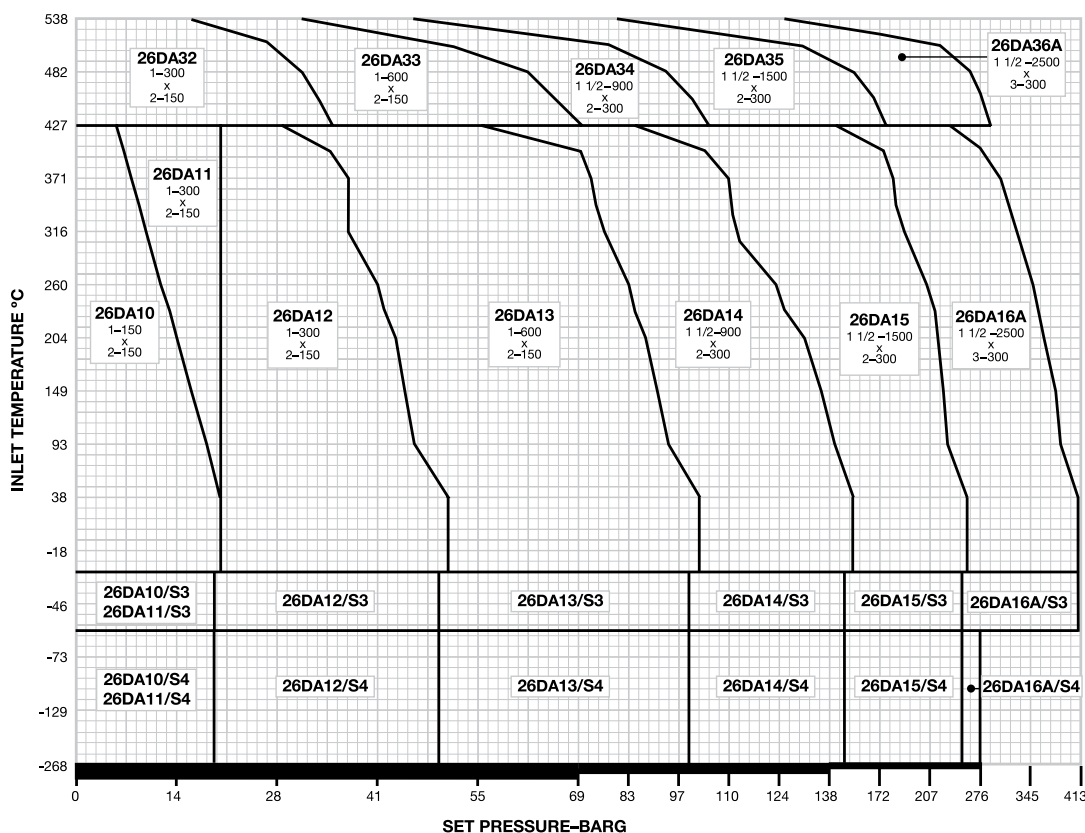

General Notes:

- The type numbers shown on the selection chart indicate conventional valves. For BalanSeal, O-ring construction, balanced piston design and other valve options, see the type numbering system on pages 10 and 11.
- Outlet pressure for temperatures above 38°C should not exceed the rating in ANSI B16.5.
- For applications above 538°C, consult the Farris Factory.



E Orifice

Metric Units, API Area: 126 mm ² , Actual Area: 145 mm ²															
Type Number		Valve Size	ANSI Flange Class		Maximum Set Pressure, barg					Back Pressure Limit barg @ 38°C		Material		Inlet Temp. Range	
Conventional	BalanSeal	Inlet Outlet	Inlet RF or RJ	Outlet RF	-268°C -60°C	-59°C -30°C	-29°C +38°C	+232°C	+427°C	+538°C	Conventional Type	Balan-Seal Type	Body & Bonnet		Spring
26EA10	26EB10	1 x 2	150#	150#			19.6	12.7	5.5		19.6	15.8	Carbon Steel	Chrome Alloy	-29°C to 427°C
26EA11	26EB11	1 x 2	300#	150#			19.6	19.6	19.6		19.6	15.8			
26EA12	26EB12	1 x 2	300#	150#			51.0	42.4	28.2		19.6	15.8			
26EA13	26EB13	1 x 2	600#	150#			102	85.1	56.8		19.6	15.8			
26EA14		1 1/2 x 2	900#	300#			153	127	85.1		41.3	34.5			
26EA15		1 1/2 x 2	1500#	300#			255	212	142		41.3	34.5			
26EA16A		1 1/2 x 3	2500#	300#			413	354	236		51	34.5			
26EA32	26EB32	1 x 2	300#	150#					35.1	15.5	19.6	15.8	Chrome Moly Steel	High Temp. Alloy	428°C to 538°C
26EA33	26EB33	1 x 2	600#	150#					69.9	30.6	19.6	15.8			
26EA34		1 1/2 x 2	900#	300#					105	46.2	41.3	34.5			
26EA35		1 1/2 x 2	1500#	300#					175	76.8	41.3	34.5			
26EA36A		1 1/2 x 3	2500#	300#					291	128	51	34.5			
26EA10/S3	26EB10/S3	1 x 2	150#	150#		18.9					18.9	15.8	316 St. St.	Chrome Alloy Nickel Plated	-30°C to -59°C
26EA11/S3	26EB11/S3	1 x 2	300#	150#		18.9					18.9	15.8			
26EA12/S3	26EB12/S3	1 x 2	300#	150#		49.6					18.9	15.8			
26EA13/S3	26EB13/S3	1 x 2	600#	150#		99.2					18.9	15.8			
26EA14/S3		1 1/2 x 2	900#	300#		149					41.3	34.5			
26EA15/S3		1 1/2 x 2	1500#	300#		248					41.3	34.5			
26EA16A/S3		1 1/2 x 3	2500#	300#		413					49.6	34.5			
26EA10/S4	26EB10/S4	1 x 2	150#	150#	18.9						18.9	15.8	316 St. St.	316 St. St.	-60°C to -268°C
26EA11/S4	26EB11/S4	1 x 2	300#	150#	18.9						18.9	15.8			
26EA12/S4	26EB12/S4	1 x 2	300#	150#	49.6						18.9	15.8			
26EA13/S4	26EB13/S4	1 x 2	600#	150#	99.2						18.9	15.8			
26EA14/S4		1 1/2 x 2	900#	300#	149						41.3	34.5			
26EA15/S4		1 1/2 x 2	1500#	300#	248						41.3	34.5			
26EA16A/S4		1 1/2 x 3	2500#	300#	276						49.6	34.5			

Selection Chart

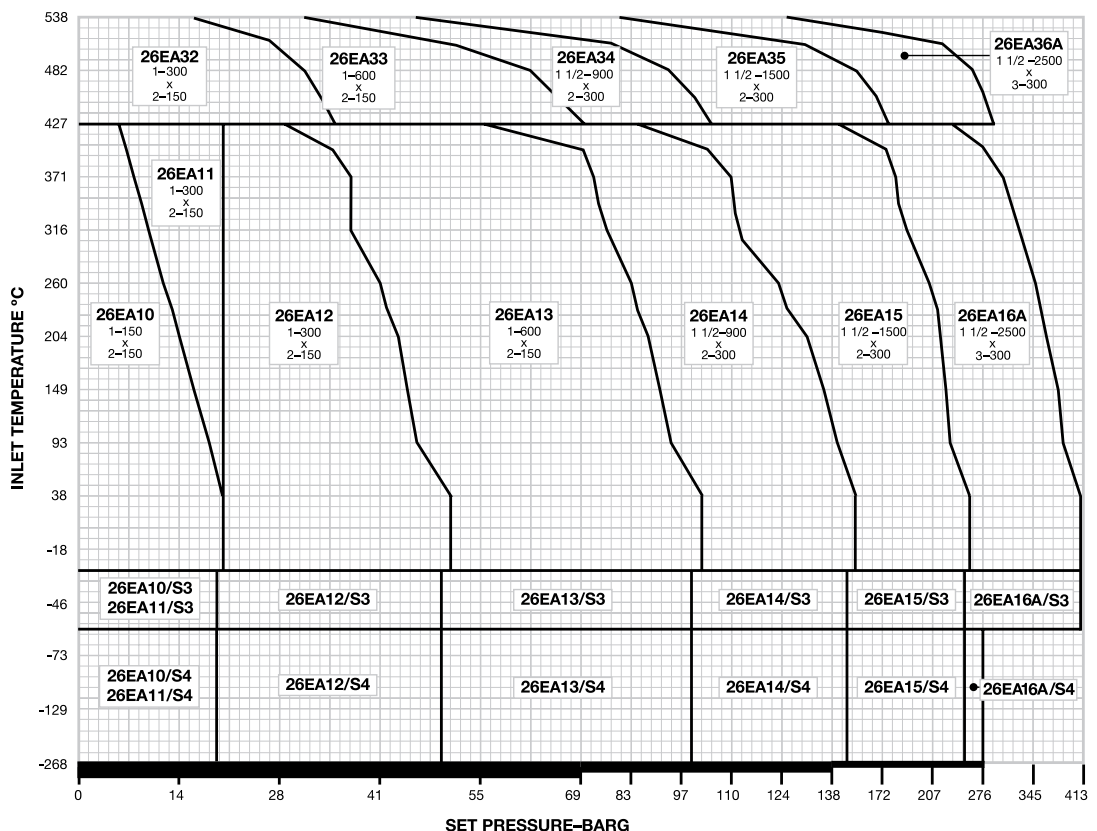

General Notes:

1. The type numbers shown on the selection chart indicate conventional valves. For BalanSeal, O-ring construction, balanced piston design and other valve options, see the type numbering system on pages 10 and 11.
2. Outlet pressure for temperatures above 38°C should not exceed the rating in ANSI B16.5.
3. For applications above 538°C, consult the Farris Factory.

F Orifice

Metric Units, API Area: 198 mm ² , Actual Area: 239 mm ²															
Type Number		Valve Size	ANSI Flange Class		Maximum Set Pressure, barg						Back Pressure Limit barg @ 38°C		Material		Inlet Temp. Range
Conventional	BalanSeal	Inlet Outlet	Inlet RF or RJ	Outlet RF	-268°C -60°C	-59°C -30°C	-29°C +38°C	+232°C	+427°C	+538°C	Conventional Type	Balan-Seal Type	Body & Bonnet	Spring	
26FA10	26FB10	1 1/2 x 2	150#	150#			19.6	12.7	5.5		19.6	15.8	Carbon Steel	Chrome Alloy	-29°C to 427°C
26FA11	26FB11	1 1/2 x 2	300#	150#			19.6	19.6	19.6		19.6	15.8			
26FA12	26FB12	1 1/2 x 2	300#	150#			51.0	42.4	28.2		19.6	15.8			
26FA13	26FB13	1 1/2 x 2	600#	150#			102	85.1	56.8		19.6	15.8			
26FA14A	26FB14A	1 1/2 x 3	900#	300#			153	127	85.1		51.0	34.5			
26FA15A	26FB15A	1 1/2 x 3	1500#	300#			255	212	142		51.0	34.5			
26FA16A	26FB16A	1 1/2 x 3	2500#	300#			345	345	236		51.0	34.5			
26FA32	26FB32	1 1/2 x 2	300#	150#					35.1	15.5	19.6	15.8	Chrome Moly Steel	High Temp. Alloy	428°C to 538°C
26FA33	26FB33	1 1/2 x 2	600#	150#					69.9	30.6	19.6	15.8			
26FA34A	26FB34A	1 1/2 x 3	900#	300#					105	46.2	51.0	34.5			
26FA35A	26FB35A	1 1/2 x 3	1500#	300#					175	76.8	51.0	34.5			
26FA36A	26FB36A	1 1/2 x 3	2500#	300#					291	128	51.0	34.5			
26FA10/S3	26FB10/S3	1 1/2 x 2	150#	150#		18.9					18.9	15.8	316 St. St.	Chrome Alloy Nickel Plated	-30°C to -59°C
26FA11/S3	26FB11/S3	1 1/2 x 2	300#	150#		18.9					18.9	15.8			
26FA12/S3	26FB12/S3	1 1/2 x 2	300#	150#		49.6					18.9	15.8			
26FA13/S3	26FB13/S3	1 1/2 x 2	600#	150#		99.2					18.9	15.8			
26FA14A/S3	26FB14A/S3	1 1/2 x 3	900#	300#		149					49.6	34.5			
26FA15A/S3	26FB15A/S3	1 1/2 x 3	1500#	300#		248					49.6	34.5			
26FA16A/S3	26FB16A/S3	1 1/2 x 3	2500#	300#		345					49.6	34.5			
26FA10/S4	26FB10/S4	1 1/2 x 2	150#	150#	18.9						18.9	15.8	316 St. St.	316 St. St.	-60°C to -268°C
26FA11/S4	26FB11/S4	1 1/2 x 2	300#	150#	18.9						18.9	15.8			
26FA12/S4	26FB12/S4	1 1/2 x 2	300#	150#	49.6						18.9	15.8			
26FA13/S4	26FB13/S4	1 1/2 x 2	600#	150#	99.2						18.9	15.8			
26FA14A/S4	26FB14A/S4	1 1/2 x 3	900#	300#	149						49.6	34.5			
26FA15A/S4	26FB15A/S4	1 1/2 x 3	1500#	300#	152						49.6	34.5			
26FA16A/S4	26FB16A/S4	1 1/2 x 3	2500#	300#	234						49.6	34.5			

Selection Chart

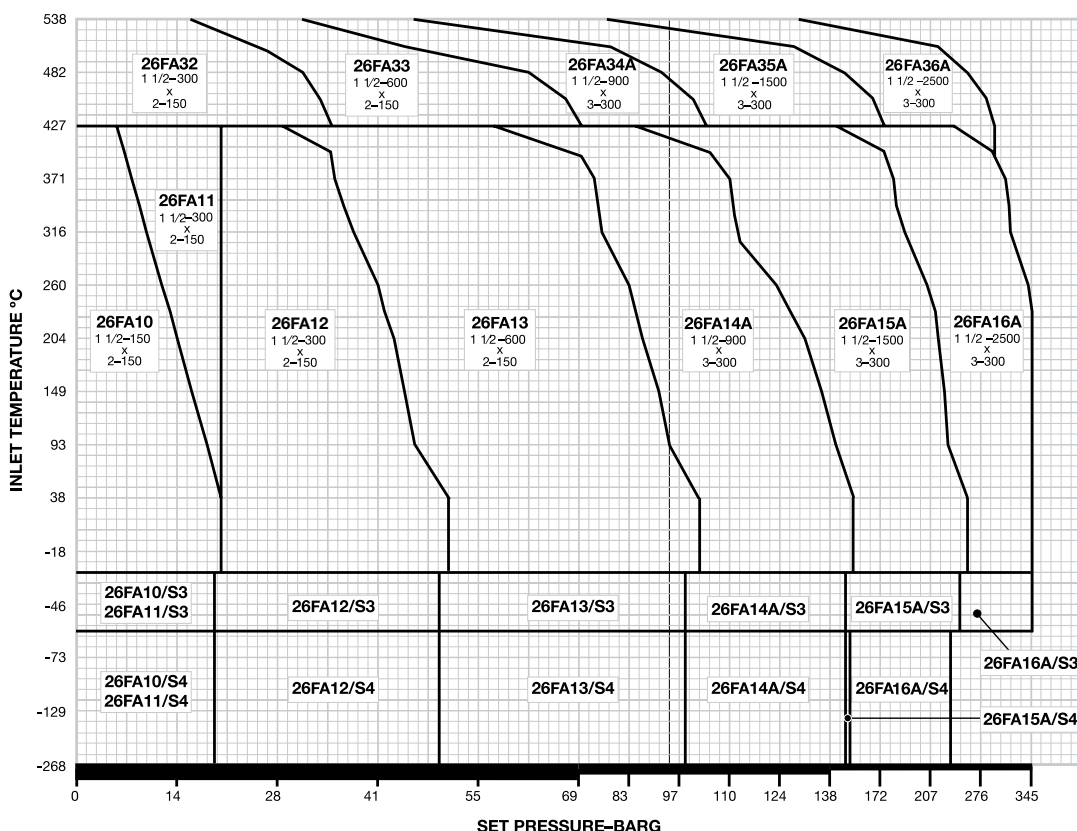

General Notes:

- The type numbers shown on the selection chart indicate conventional valves. For BalanSeal, O-ring construction, balanced piston design and other valve options, see the type numbering system on pages 10 and 11.
- Outlet pressure for temperatures above 38°C should not exceed the rating in ANSI B16.5.
- For applications above 538°C, consult the Farris Factory.



G Orifice

Metric Units, API Area: 325 mm ² , Actual Area: 361 mm ²															
Type Number		Valve Size	ANSI Flange Class		Maximum Set Pressure, barg						Back Pressure Limit barg @ 38°C		Material		Inlet Temp. Range
Conventional	BalanSeal	Inlet Outlet	Inlet RF or RJ	Outlet RF	-268°C -60°C	-59°C -30°C	-29°C +38°C	+232°C	+427°C	+538°C	Conventional Type	Balan-Seal Type	Body & Bonnet	Spring	
26GA10A	26GB10A	1 1/2 x 3	150#	150#			19.6	12.7	5.5		19.6	15.8	Carbon Steel	Chrome Alloy	-29°C to 427°C
26GA11A	26GB11A	1 1/2 x 3	300#	150#			19.6	19.6	19.6		19.6	15.8			
26GA12A	26GB12A	1 1/2 x 3	300#	150#			51.0	42.4	28.2		19.6	15.8			
26GA13A	26GB13A	1 1/2 x 3	600#	150#			102	85.1	56.8		19.6	15.8			
26GA14A	26GB14A	1 1/2 x 3	900#	300#			153	127	85.1		51.0	32.4			
26GA15	26GB15	2 x 3	1500#	300#			255	212	142		51.0	32.4			
26GA16	26GB16	2 x 3	2500#	300#			255	255	236		51.0	32.4			
26GA32A	26GB32A	1 1/2 x 3	300#	150#					35.1	15.5	19.6	15.8	Chrome Moly Steel	High Temp. Alloy	428°C to 538°C
26GA33A	26GB33A	1 1/2 x 3	600#	150#					69.9	30.6	19.6	15.8			
26GA34A	26GB34A	1 1/2 x 3	900#	300#					105	46.2	51.0	32.4			
26GA35	26GB35	2 x 3	1500#	300#					175	76.8	51.0	32.4			
26GA36	26GB36	2 x 3	2500#	300#					255	128	51.0	32.4			
26GA10A/S3	26GB10A/S3	1 1/2 x 3	150#	150#		18.9					18.9	15.8	316 St. St.	Chrome Alloy Nickel Plated	-30°C to -59°C
26GA11A/S3	26GB11A/S3	1 1/2 x 3	300#	150#		18.9					18.9	15.8			
26GA12A/S3	26GB12A/S3	1 1/2 x 3	300#	150#		49.6					18.9	15.8			
26GA13A/S3	26GB13A/S3	1 1/2 x 3	600#	150#		99.2					18.9	15.8			
26GA14A/S3	26GB14A/S3	1 1/2 x 3	900#	300#		149					49.6	32.4			
26GA15/S3	26GB15/S3	2 x 3	1500#	300#		248					49.6	32.4			
26GA16/S3	26GB16/S3	2 x 3	2500#	300#		248					49.6	32.4			
26GA10A/S4	26GB10A/S4	1 1/2 x 3	150#	150#	18.9						18.9	15.8	316 St. St.	316 St. St.	-60°C to -268°C
26GA11A/S4	26GB11A/S4	1 1/2 x 3	300#	150#	18.9						18.9	15.8			
26GA12A/S4	26GB12A/S4	1 1/2 x 3	300#	150#	49.6						18.9	15.8			
26GA13A/S4	26GB13A/S4	1 1/2 x 3	600#	150#	99.2						18.9	15.8			
26GA14A/S4	26GB14A/S4	1 1/2 x 3	900#	300#	110						49.6	32.4			
26GA15/S4	26GB15/S4	2 x 3	1500#	300#	169						49.6	32.4			
26GA16/S4	26GB16/S4	2 x 3	2500#	300#	179						49.6	32.4			

Selection Chart

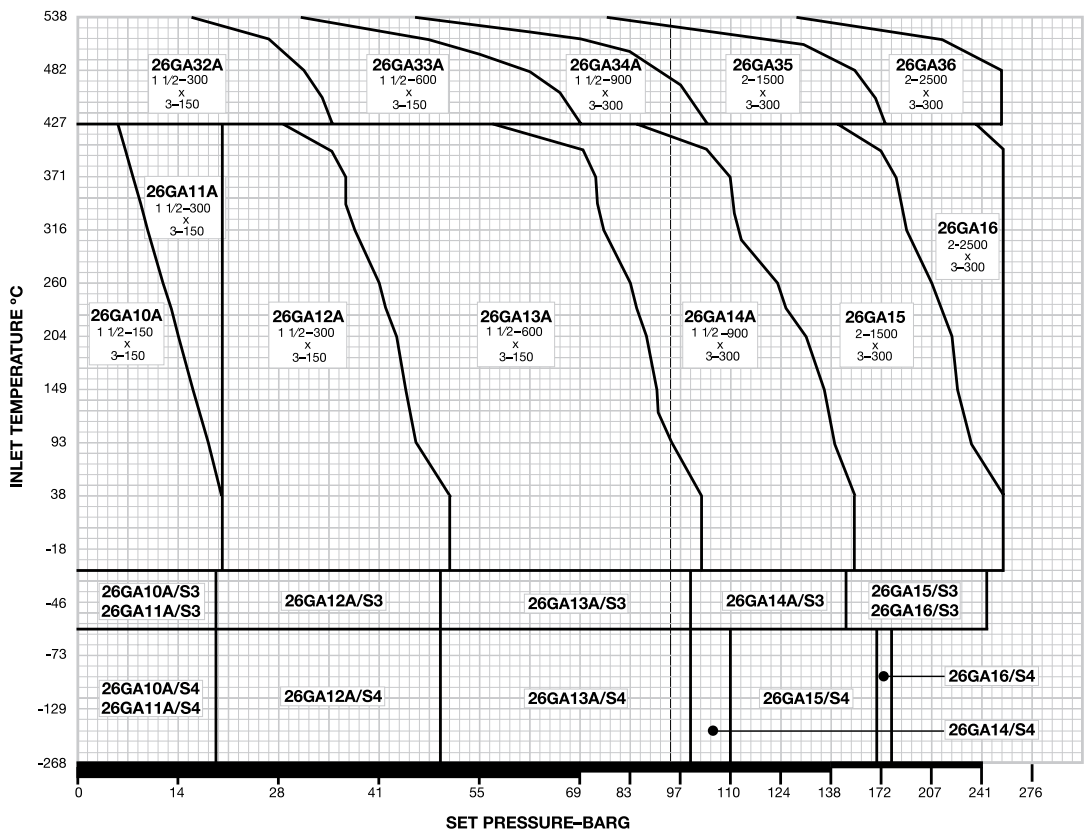

General Notes:

- The type numbers shown on the selection chart indicate conventional valves. For BalanSeal, O-ring construction, balanced piston design and other valve options, see the type numbering system on pages 10 and 11.
- Outlet pressure for temperatures above 38°C should not exceed the rating in ANSI B16.5.
- For applications above 538°C, consult the Farris Factory.

H Orifice

Metric Units, API Area: 506 mm ² , Actual Area: 563 mm ²															
Type Number		Valve Size	ANSI Flange Class		Maximum Set Pressure, barg						Back Pressure Limit barg @ 38°C		Material		Inlet Temp. Range
Conventional	BalanSeal	Inlet Outlet	Inlet RF or RJ	Outlet RF	-268°C -60°C	-59°C -30°C	-29°C +38°C	+232°C	+427°C	+538°C	Conventional Type	Balan-Seal Type	Body & Bonnet	Spring	
26HA10	26HB10	1 1/2 x 3	150#	150#			19.6	12.7	5.5		19.6	15.8	Carbon Steel	Chrome Alloy	-29°C to 427°C
26HA11	26HB11	1 1/2 x 3	300#	150#			19.6	19.6	19.6		19.6	15.8			
26HA12	26HB12	2 x 3	300#	150#			51.0	42.4	28.2		19.6	15.8			
26HA13	26HB13	2 x 3	600#	150#			102	85.1	56.8		19.6	15.8			
26HA14	26HB14	2 x 3	900#	150#			153	127	85.1		19.6	15.8			
26HA15	26HB15	2 x 3	1500#	300#			189	189	142		51.0	28.6			
26HA32	26HB32	2 x 3	300#	150#					35.1	15.5	19.6	15.8	Chrome Moly Steel	High Temp. Alloy	428°C to 538°C
26HA33	26HB33	2 x 3	600#	150#					56.2	30.6	19.6	15.8			
26HA34	26HB34	2 x 3	900#	150#					84.4	46.2	19.6	15.8			
26HA35	26HB35	2 x 3	1500#	300#					141	76.8	51.0	28.6			
26HA10/S3	26HB10/S3	1 1/2 x 3	150#	150#		18.9					18.9	15.8	316 St. St.	Chrome Alloy Nickel Plated	-30°C to -59°C
26HA11/S3	26HB11/S3	1 1/2 x 3	300#	150#		18.9					18.9	15.8			
26HA12/S3	26HB12/S3	2 x 3	300#	150#		49.6					18.9	15.8			
26HA13/S3	26HB13/S3	2 x 3	600#	150#		99.2					18.9	15.8			
26HA14/S3	26HB14/S3	2 x 3	900#	150#		149					18.9	15.8			
26HA15/S3	26HB15/S3	2 x 3	1500#	300#		189					49.6	28.6			
26HA10/S4	26HB10/S4	1 1/2 x 3	150#	150#	18.9						18.9	15.8	316 St. St.	316 St. St.	-60°C to -268°C
26HA11/S4	26HB11/S4	1 1/2 x 3	300#	150#	18.9						18.9	15.8			
26HA12/S4	26HB12/S4	2 x 3	300#	150#	49.6						18.9	15.8			
26HA13/S4	26HB13/S4	2 x 3	600#	150#	99.2						18.9	15.8			
26HA14/S4	26HB14/S4	2 x 3	900#	150#	102						18.9	15.8			
26HA15/S4	26HB15/S4	2 x 3	1500#	300#	110						49.6	28.6			

Selection Chart

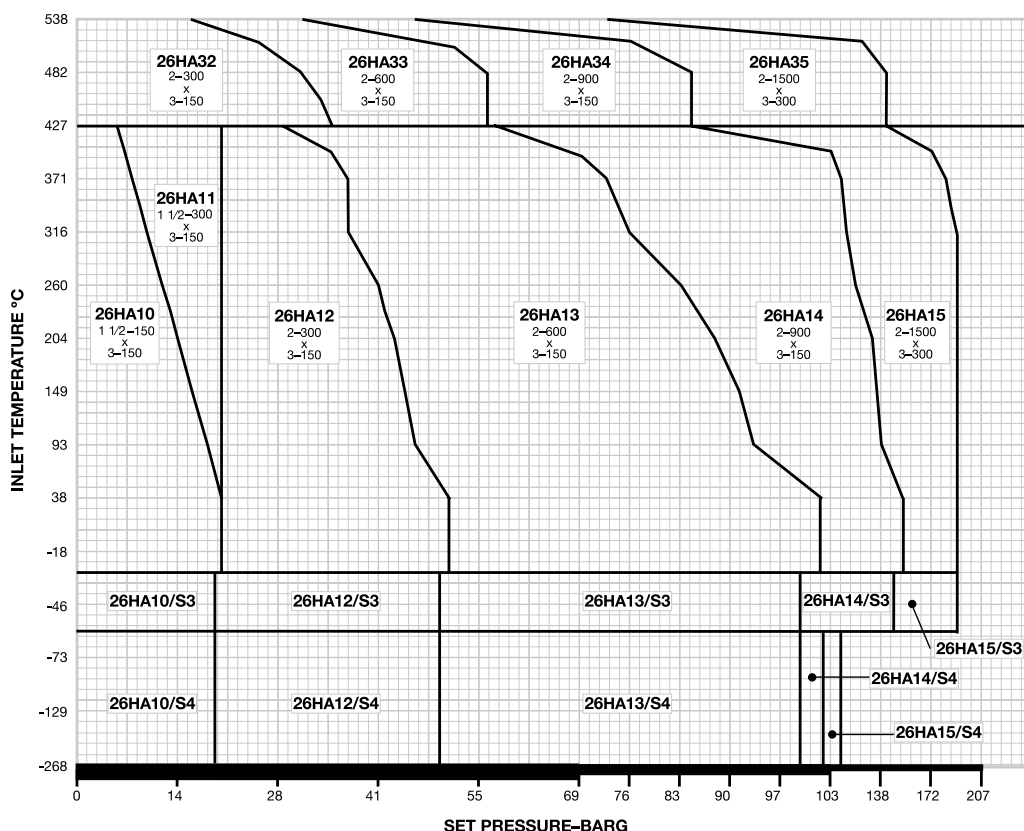

General Notes:

1. The type numbers shown on the selection chart indicate conventional valves. For BalanSeal, O-ring construction, balanced piston design and other valve options, see the type numbering system on pages 10 and 11.
2. Outlet pressure for temperatures above 38°C should not exceed the rating in ANSI B16.5.
3. For applications above 538°C, consult the Farris Factory.

J Orifice

Metric Units, API Area: 830 mm ² , Actual Area: 923 mm ²															
Type Number		Valve Size	ANSI Flange Class		Maximum Set Pressure, barg						Back Pressure Limit barg @ 38°C		Material		Inlet Temp. Range
Conventional	BalanSeal	Inlet Outlet	Inlet RF or RJ	Outlet RF	-268°C -60°C	-59°C -30°C	-29°C +38°C	+232°C	+427°C	+538°C	Conventional Type	Balan-Seal Type	Body & Bonnet	Spring	
26JA10	26JB10	2 x 3	150#	150#			19.6	12.7	5.5		19.6	15.8	Carbon Steel	Chrome Alloy	-29°C to 427°C
26JA11	26JB11	2 x 3	300#	150#			19.6	19.6	19.6		19.6	15.8			
26JA12A	26JB12A	3 x 4	300#	150#			51.0	42.4	28.2		19.6	15.8			
26JA13A	26JB13A	3 x 4	600#	150#			102	85.1	56.8		19.6	15.8			
26JA14	26JB14	3 x 4	900#	150#			153	127	85.1		19.6	15.8			
26JA15	26JB15	3 x 4	1500#	300#			186	186	142		41.3	15.8			
26JA32A	26JB32A	3 x 4	300#	150#					35.1	15.5	19.6	15.8	Chrome Moly Steel	High Temp. Alloy	428°C to 538°C
26JA33A	26JB33A	3 x 4	600#	150#					56.2	30.6	19.6	15.8			
26JA34A	26JB34A	3 x 4	900#	150#					84.4	46.2	19.6	15.8			
26JA35	26JB35	3 x 4	1500#	300#					141	76.8	41.3	15.8			
26JA10/S3	26JB10/S3	2 x 3	150#	150#		18.9					18.9	15.8	316 St. St.	Chrome Alloy Nickel Plated	-30°C to -59°C
26JA11/S3	26JB11/S3	2 x 3	300#	150#		18.9					18.9	15.8			
26JA12A/S3	26JB12A/S3	3 x 4	300#	150#		49.6					18.9	15.8			
26JA13A/S3	26JB13A/S3	3 x 4	600#	150#		99.2					18.9	15.8			
26JA14/S3	26JB14/S3	3 x 4	900#	150#		149					18.9	15.8			
26JA15/S3	26JB15/S3	3 x 4	1500#	300#		186					41.3	15.8			
26JA10/S4	26JB10/S4	2 x 3	150#	150#	18.9						18.9	15.8	316 St. St.	316 St. St.	-60°C to -268°C
26JA11/S4	26JB11/S4	2 x 3	300#	150#	18.9						18.9	15.8			
26JA12A/S4	26JB12A/S4	3 x 4	300#	150#	34.5						18.9	15.8			
26JA13A/S4	26JB13A/S4	3 x 4	600#	150#	43.1						18.9	15.8			
26JA14/S4	26JB14/S4	3 x 4	900#	150#	55						18.9	15.8			
26JA15/S4	26JB15/S4	3 x 4	1500#	300#	55						41.3	15.8			

Selection Chart

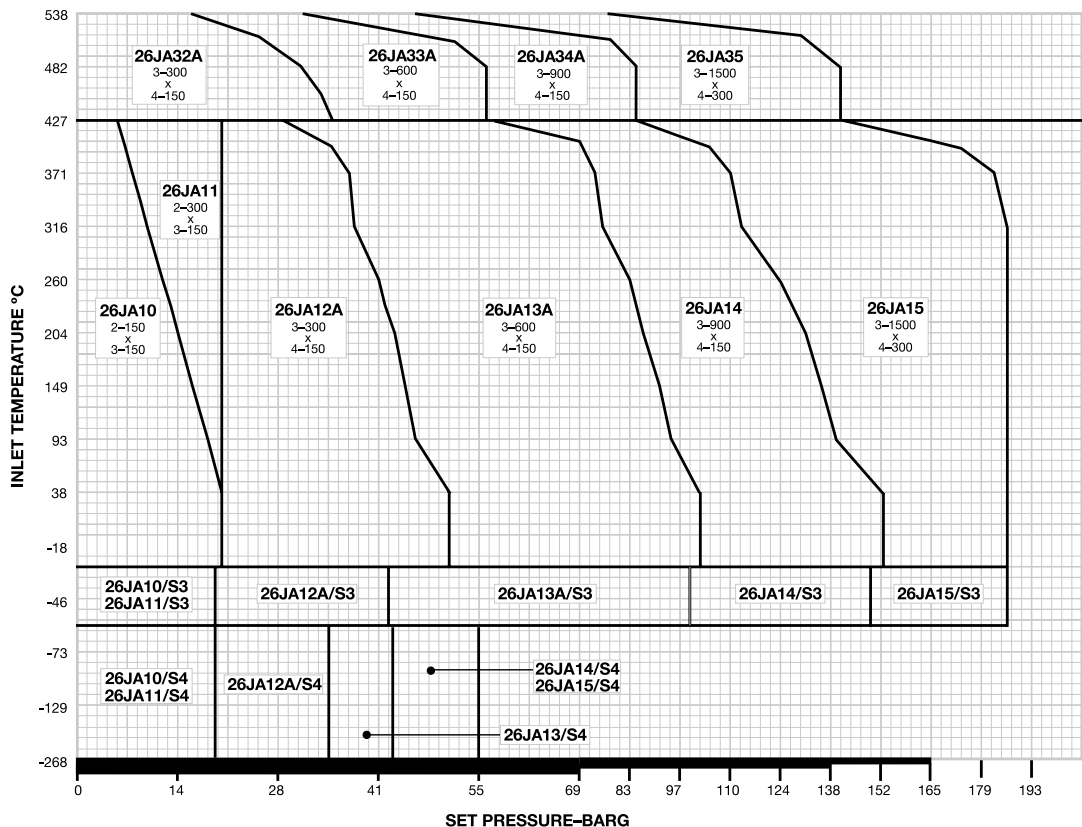

General Notes:

1. The type numbers shown on the selection chart indicate conventional valves. For BalanSeal, O-ring construction, balanced piston design and other valve options, see the type numbering system on pages 10 and 11.
2. Outlet pressure for temperatures above 38°C should not exceed the rating in ANSI B16.5.
3. For applications above 538°C, consult the Farris Factory.

K Orifice

Metric Units, API Area: 1186 mm ² , Actual Area: 1317 mm ²															
Type Number		Valve Size	ANSI Flange Class		Maximum Set Pressure, barg					Back Pressure Limit barg @ 38°C		Material		Inlet Temp. Range	
Conventional	BalanSeal	Inlet Outlet	Inlet RF or RJ	Outlet RF	-268°C -60°C	-59°C -30°C	-29°C +38°C	+232°C	+427°C	+538°C	Conventional Type	Balan-Seal Type	Body & Bonnet		Spring
26KA10	26KB10	3 x 4	150#	150#			19.6	12.7	5.5		19.6	10.3	Carbon Steel	Chrome Alloy	-29°C to 427°C
26KA11	26KB11	3 x 4	300#	150#			19.6	19.6	19.6		19.6	10.3			
26KA12	26KB12	3 x 4	300#	150#			51.0	42.4	28.2		19.6	10.3			
26KA13	26KB13	3 x 4	600#	150#			102	85.1	56.8		19.6	13.8			
26KA14	26KB14	3 x 6	900#	150#			153	127	85.1		19.6	13.8			
26KA15	26KB15	3 x 6	1500#	300#			153	153	142		41.3	13.8			
26KA32	26KB32	3 x 4	300#	150#					35.1	15.5	19.6	10.3	Chrome Moly Steel	High Temp. Alloy	428°C to 538°C
26KA33	26KB33	3 x 4	600#	150#					56.2	30.6	19.6	13.8			
26KA34A	26KB34A	3 x 6	900#	150#					84.4	46.2	19.6	13.8			
26KA35	26KB35	3 x 6	1500#	300#					141	76.8	41.3	13.8			
26KA10/S3	26KB10/S3	3 x 4	150#	150#		18.9					18.9	10.3	316 St. St.	Chrome Alloy Nickel Plated	-30°C to -59°C
26KA11/S3	26KB11/S3	3 x 4	300#	150#		18.9					18.9	10.3			
26KA12/S3	26KB12/S3	3 x 4	300#	150#		49.6					18.9	10.3			
26KA13/S3	26KB13/S3	3 x 4	600#	150#		99.2					18.9	13.8			
26KA14/S3	26KB14/S3	3 x 6	900#	150#		149					18.9	13.8			
26KA15/S3	26KB15/S3	3 x 6	1500#	300#		153					41.3	13.8			
26KA10/S4	26KB10/S4	3 x 4	150#	150#	18.9						18.9	10.3	316 St. St.	316 St. St.	-60°C to -268°C
26KA11/S4	26KB11/S4	3 x 4	300#	150#	18.9						18.9	10.3			
26KA12/S4	26KB12/S4	3 x 4	300#	150#	36.2						18.9	10.3			
26KA13/S4	26KB13/S4	3 x 4	600#	150#	41.3						18.9	13.8			
26KA14/S4	26KB14/S4	3 x 6	900#	150#	41.3						18.9	13.8			
26KA15/S4	26KB15/S4	3 x 6	1500#	300#	51.7						41.3	13.8			

Selection Chart

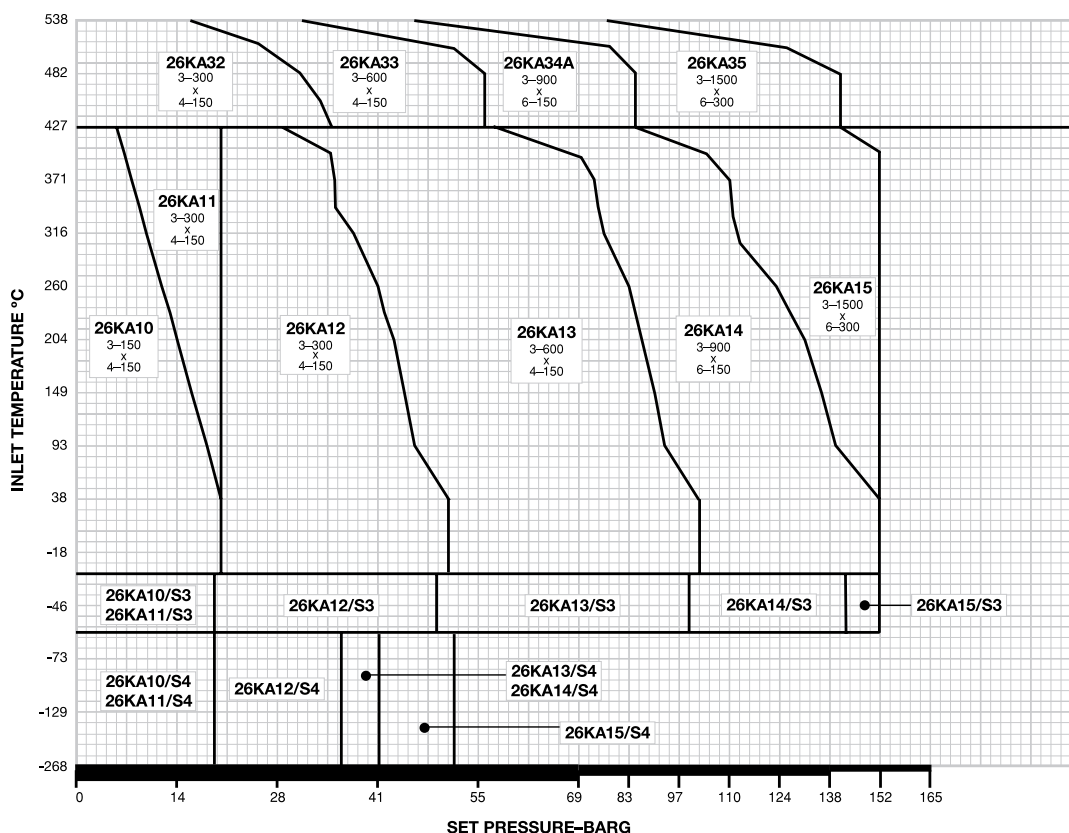

General Notes:

1. The type numbers shown on the selection chart indicate conventional valves. For BalanSeal, O-ring construction, balanced piston design and other valve options, see the type numbering system on pages 10 and 11.
2. Outlet pressure for temperatures above 38°C should not exceed the rating in ANSI B16.5.
3. For applications above 538°C, consult the Farris Factory.



L Orifice

Metric Units, API Area: 1841 mm ² , Actual Area: 2045 mm ²															
Type Number		Valve Size	ANSI Flange Class		Maximum Set Pressure, barg						Back Pressure Limit barg @ 38°C		Material		Inlet Temp. Range
Conventional	BalanSeal	Inlet Outlet	Inlet RF or RJ	Outlet RF	-268°C -60°C	-59°C -30°C	-29°C +38°C	+232°C	+427°C	+538°C	Conventional Type	Balan-Seal Type	Body & Bonnet	Spring	
26LA10	26LB10	3 x 4	150#	150#			19.6	12.7	5.5		19.6	6.9	Carbon Steel	Chrome Alloy	-29°C to 427°C
26LA11	26LB11	3 x 4	300#	150#			19.6	19.6	19.6		19.6	6.9			
26LA12	26LB12	4 x 6	300#	150#			51.0	42.4	28.2		19.6	11.7			
26LA13	26LB13	4 x 6	600#	150#			68.9	68.9	56.8		19.6	11.7			
26LA14	26LB14	4 x 6	900#	150#			103	103	85.1		19.6	11.7			
26LA15	26LB15	4 x 6	1500#	150#			103	103	103		19.6	11.7			
26LA32	26LB32	4 x 6	300#	150#					35.1	15.5	19.6	11.7	Chrome Moly Steel	High Temp. Alloy	428°C to 538°C
26LA33	26LB33	4 x 6	600#	150#					68.9	30.6	19.6	11.7			
26LA34	26LB34	4 x 6	900#	150#					103	46.2	19.6	11.7			
26LA35	26LB35	4 x 6	1500#	150#					103	76.8	19.6	11.7			
26LA10/S3	26LB10/S3	3 x 4	150#	150#		18.9					18.9	6.9	316 St. St.	Chrome Alloy Nickel Plated	-30°C to -59°C
26LA11/S3	26LB11/S3	3 x 4	300#	150#		18.9					18.9	6.9			
26LA12/S3	26LB12/S3	4 x 6	300#	150#		49.6					18.9	11.7			
26LA13/S3	26LB13/S3	4 x 6	600#	150#		68.9					18.9	11.7			
26LA14/S3	26LB14/S3	4 x 6	900#	150#		103					18.9	11.7			
26LA10/S4	26LB10/S4	3 x 4	150#	150#	18.9						18.9	6.9	316 St. St.	316 St. St.	-60°C to -268°C
26LA11/S4	26LB11/S4	3 x 4	300#	150#	18.9						18.9	6.9			
26LA12/S4	26LB12/S4	4 x 6	300#	150#	36.9						18.9	11.7			
26LA13/S4	26LB13/S4	4 x 6	600#	150#	36.9						18.9	11.7			
26LA14/S4	26LB14/S4	4 x 6	900#	150#	48.2						18.9	11.7			

Selection Chart

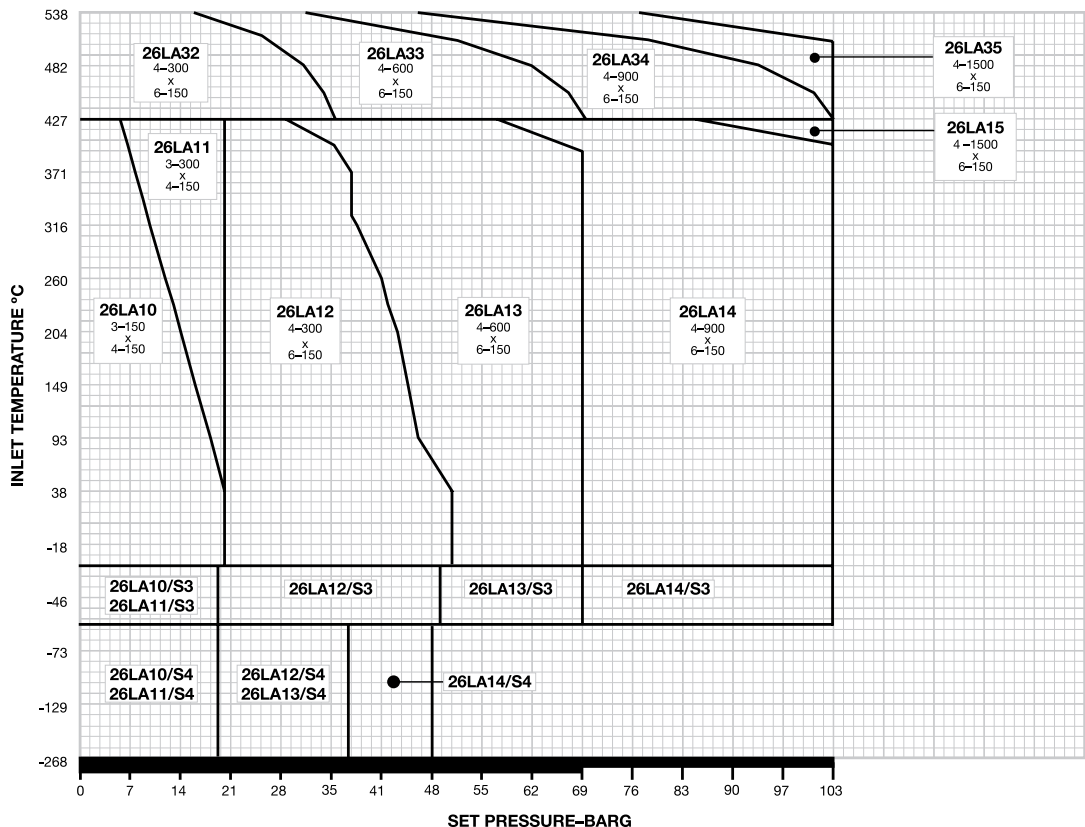

General Notes:

1. The type numbers shown on the selection chart indicate conventional valves. For BalanSeal, O-ring construction, balanced piston design and other valve options, see the type numbering system on pages 10 and 11.
2. Outlet pressure for temperatures above 38°C should not exceed the rating in ANSI B16.5.
3. For applications above 538°C, consult the Farris Factory.

M Orifice

Metric Units, API Area: 2323 mm ² , Actual Area: 2581 mm ²															
Type Number		Valve Size	ANSI Flange Class		Maximum Set Pressure, barg					Back Pressure Limit barg @ 38°C		Material		Inlet Temp. Range	
Conventional	BalanSeal	Inlet Outlet	Inlet RF or RJ	Outlet RF	-268°C -60°C	-59°C -30°C	-29°C +38°C	+232°C	+427°C	+538°C	Conventional Type	BalanSeal Type	Body & Bonnet		Spring
26MA10	26MB10	4 x 6	150#	150#			19.6	12.7	5.5		19.6	5.5	Carbon Steel	Chrome Alloy	-29°C to 427°C
26MA11	26MB11	4 x 6	300#	150#			19.6	19.6	19.6		19.6	5.5			
26MA12	26MB12	4 x 6	300#	150#			51.0	42.4	28.2		19.6	11.0			
26MA13	26MB13	4 x 6	600#	150#			75.8	75.8	56.8		19.6	11.0			
26MA14	26MB14	4 x 6	900#	150#			75.8	75.8	75.8		19.6	11.0			
26MA32	26MB32	4 x 6	300#	150#				35.1	15.5		19.6	11.0	Chrome Moly Steel	High Temp. Alloy	428°C to 538°C
26MA33	26MB33	4 x 6	600#	150#				69.9	30.6		19.6	11.0			
26MA34	26MB34	4 x 6	900#	150#				75.8	46.2		19.6	11.0			
26MA10/S3	26MB10/S3	4 x 6	150#	150#		18.9					18.9	5.5	316 St. St.	Chrome Alloy Nickel Plated	-30°C to -59°C
26MA11/S3	26MB11/S3	4 x 6	300#	150#		18.9					18.9	5.5			
26MA12/S3	26MB12/S3	4 x 6	300#	150#		49.6					18.9	11.0			
26MA13/S3	26MB13/S3	4 x 6	600#	150#		68.9					18.9	11.0			
26MA10/S4	26MB10/S4	4 x 6	150#	150#	18.9						18.9	5.5	316 St. St.	316 St. St.	-60°C to -268°C
26MA11/S4	26MB11/S4	4 x 6	300#	150#	18.9						18.9	5.5			
26MA12/S4	26MB12/S4	4 x 6	300#	150#	36.2						18.9	11.0			
26MA13/S4	26MB13/S4	4 x 6	600#	150#	41.3						18.9	11.0			

Selection Chart

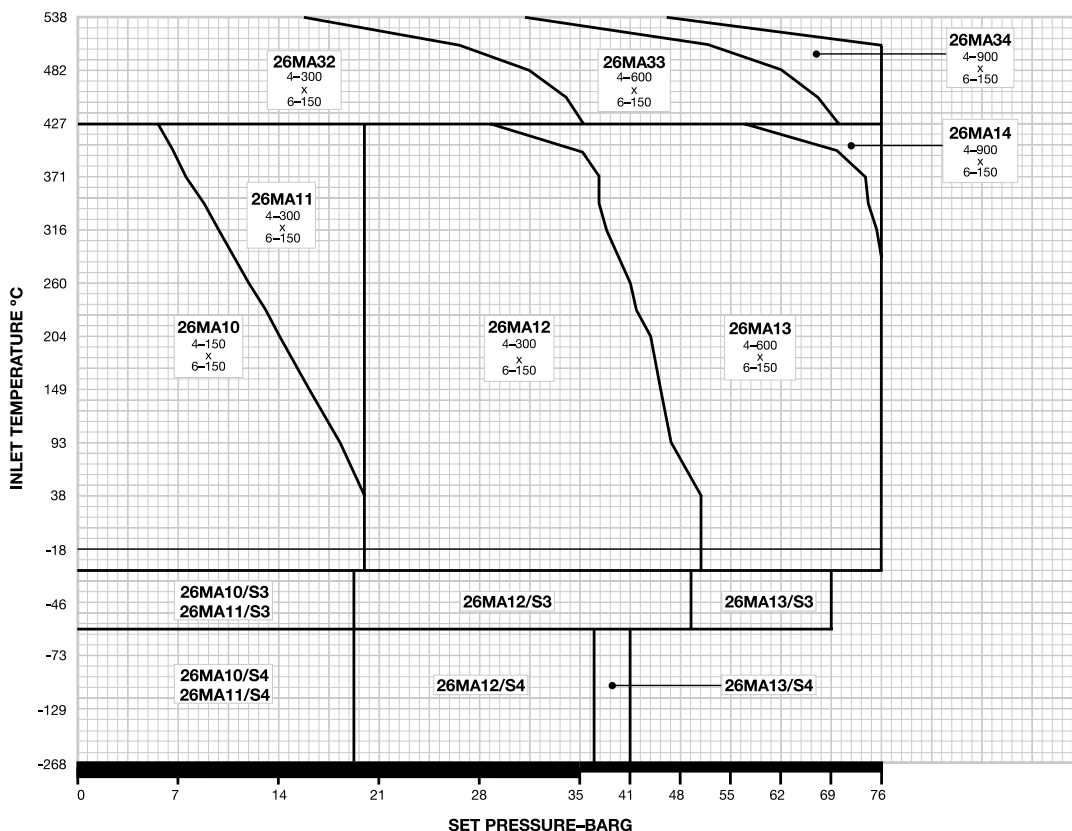

General Notes:

1. The type numbers shown on the selection chart indicate conventional valves. For BalanSeal, O-ring construction, balanced piston design and other valve options, see the type numbering system on pages 10 and 11.
2. Outlet pressure for temperatures above 38°C should not exceed the rating in ANSI B16.5.
3. For applications above 538°C, consult the Farris Factory.



N Orifice

Metric Units, API Area: 2800 mm ² , Actual Area: 3111 mm ²															
Type Number		Valve Size	ANSI Flange Class		Maximum Set Pressure, barg					Back Pressure Limit barg @ 38°C		Material		Inlet Temp. Range	
Conventional	BalanSeal	Inlet Outlet	Inlet RF or RJ	Outlet RF	-268°C -60°C	-59°C -30°C	-29°C +38°C	+232°C	+427°C	+538°C	Conventional Type	BalanSeal Type	Body & Bonnet		Spring
26NA10	26NB10	4 x 6	150#	150#			19.6	12.7	5.5		19.6	5.5	Carbon Steel	Chrome Alloy	-29°C to 427°C
26NA11	26NB11	4 x 6	300#	150#			19.6	19.6	19.6		19.6	5.5			
26NA12	26NB12	4 x 6	300#	150#			51.0	42.4	28.2		19.6	11.0			
26NA13	26NB13	4 x 6	600#	150#			68.9	68.9	56.8		19.6	11.0			
26NA14	26NB14	4 x 6	900#	150#			68.9	68.9	68.9		19.6	11.0			
26NA32	26NB32	4 x 6	300#	150#					35.1	15.5	19.6	11.0	Chrome Moly Steel	High Temp. Alloy	428°C to 538°C
26NA33	26NB33	4 x 6	600#	150#					68.9	30.6	19.6	11.0			
26NA34	26NB34	4 x 6	900#	150#					68.9	46.2	19.6	11.0			
26NA10/S3	26NB10/S3	4 x 6	150#	150#		18.9					18.9	5.5	316 St. St.	Chrome Alloy Nickel Plated	-30°C to -59°C
26NA11/S3	26NB11/S3	4 x 6	300#	150#		18.9					18.9	5.5			
26NA12/S3	26NB12/S3	4 x 6	300#	150#		49.6					18.9	11.0			
26NA13/S3	26NB13/S3	4 x 6	600#	150#		68.9					18.9	11.0			
26NA10/S4	26NB10/S4	4 x 6	150#	150#	18.9						18.9	5.5	316 St. St.	316 St. St.	-60°C to -268°C
26NA11/S4	26NB11/S4	4 x 6	300#	150#	18.9						18.9	5.5			
26NA12/S4	26NB12/S4	4 x 6	300#	150#	31.0						18.9	11.0			
26NA13/S4	26NB13/S4	4 x 6	600#	150#	34.5						18.9	11.0			

Selection Chart

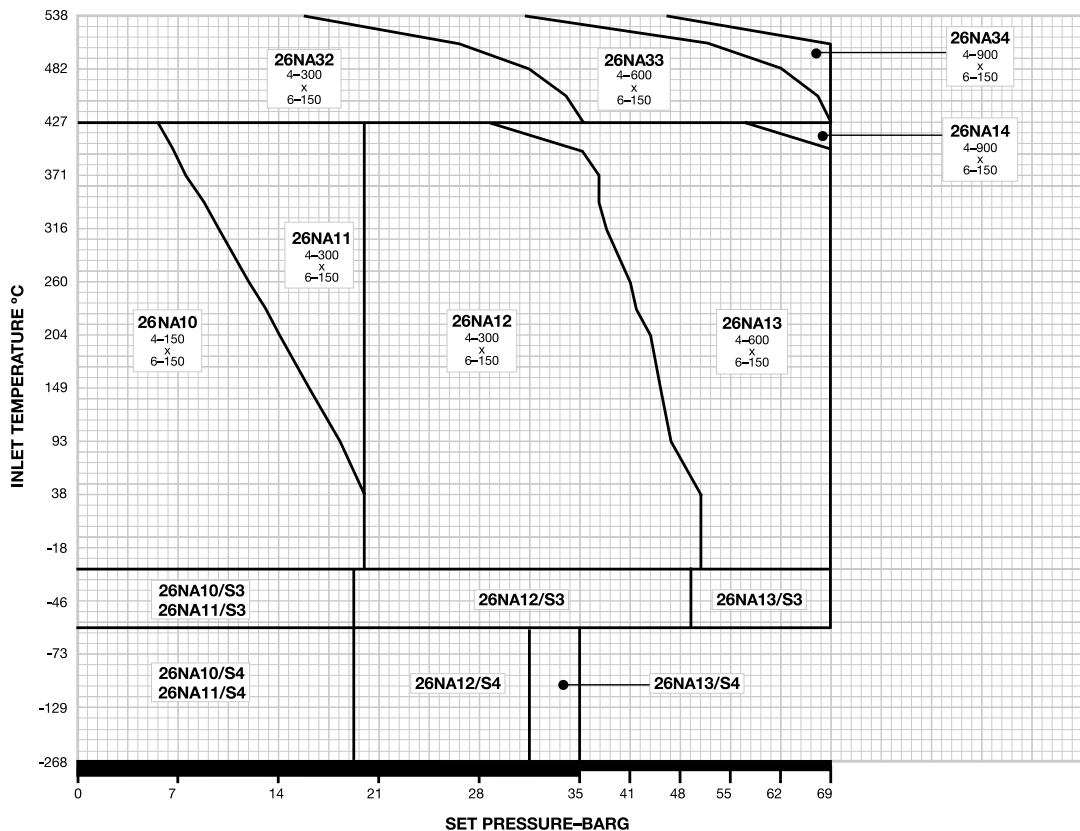

General Notes:

1. The type numbers shown on the selection chart indicate conventional valves. For BalanSeal, O-ring construction, balanced piston design and other valve options, see the type numbering system on pages 10 and 11.
2. Outlet pressure for temperatures above 38°C should not exceed the rating in ANSI B16.5.
3. For applications above 538°C, consult the Farris Factory.

P Orifice

Metric Units, API Area: 4116 mm ² , Actual Area: 4572 mm ²															
Type Number		Valve Size	ANSI Flange Class		Maximum Set Pressure, barg					Back Pressure Limit barg @ 38°C		Material		Inlet Temp. Range	
Conventional	BalanSeal	Inlet Outlet	Inlet RF or RJ	Outlet RF	-268°C -60°C	-59°C -30°C	-29°C +38°C	+232°C	+427°C	+538°C	Conventional Type	Balan-Seal Type	Body & Bonnet		Spring
26PA10	26PB10	4 x 6	150#	150#			19.6	12.7	5.5		19.6	5.5	Carbon Steel	Chrome Alloy	-29°C to 427°C
26PA11	26PB11	4 x 6	300#	150#			19.6	19.6	19.6		19.6	5.5			
26PA12	26PB12	4 x 6	300#	150#			36.2	36.2	28.2		19.6	10.3			
26PA13	26PB13	4 x 6	600#	150#			68.9	68.9	56.8		19.6	10.3			
26PA14	26PB14	4 x 6	900#	150#			68.9	68.9	68.9		19.6	10.3			
26PA32	26PB32	4 x 6	300#	150#					35.1	15.5	19.6	10.3	Chrome Moly Steel	High Temp. Alloy	428°C to 538°C
26PA33	26PB33	4 x 6	600#	150#					68.9	30.6	19.6	10.3			
26PA34	26PB34	4 x 6	900#	150#					68.9	46.2	19.6	10.3			
26PA10/S3	26PB10/S3	4 x 6	150#	150#		18.9					18.9	5.5	316 St. St.	Chrome Alloy Nickel Plated	-30°C to -59°C
26PA11/S3	26PB11/S3	4 x 6	300#	150#		18.9					18.9	5.5			
26PA12/S3	26PB12/S3	4 x 6	300#	150#		49.6					18.9	10.3			
26PA13/S3	26PB13/S3	4 x 6	600#	150#		68.9					18.9	10.3			
26PA10/S4	26PB10/S4	4 x 6	150#	150#	12.1						12.1	5.5	316 St. St.	316 St. St.	-60°C to -268°C
26PA11/S4	26PB11/S4	4 x 6	300#	150#	12.1						12.1	5.5			
26PA12/S4	26PB12/S4	4 x 6	300#	150#	20.7						18.9	10.3			
26PA13/S4	26PB13/S4	4 x 6	600#	150#	33.1						18.9	10.3			

Selection Chart

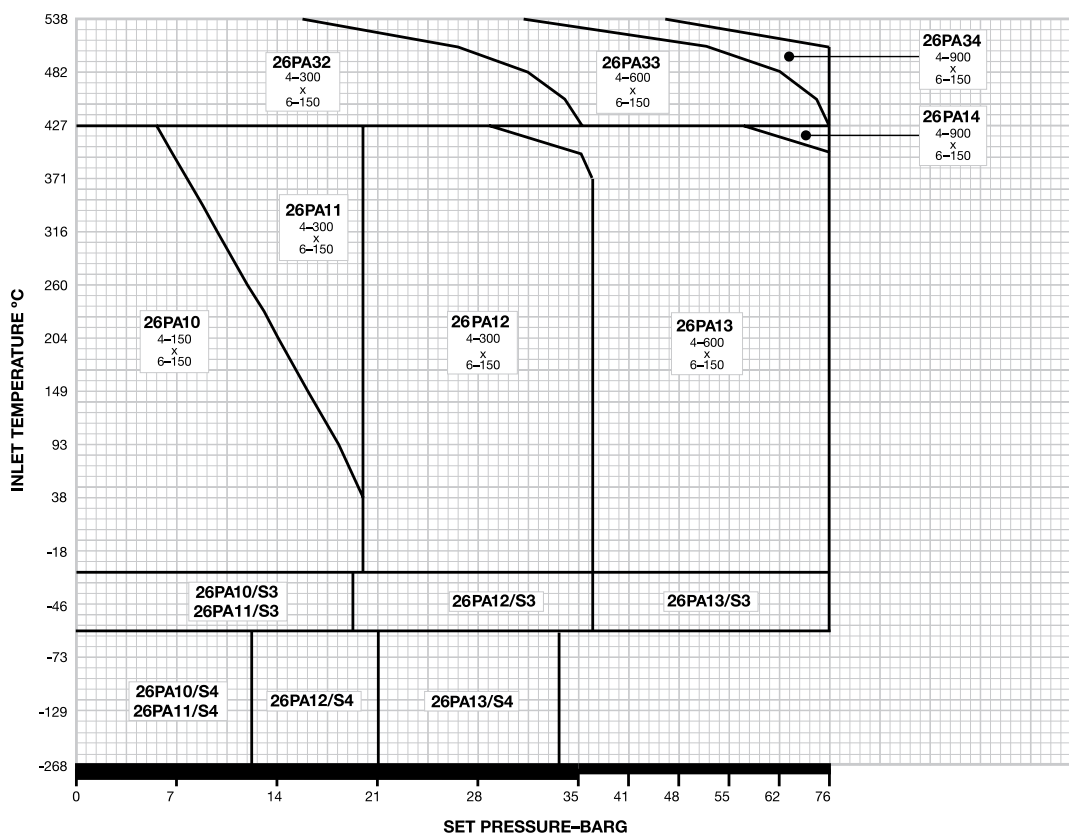

General Notes:

1. The type numbers shown on the selection chart indicate conventional valves. For BalanSeal, O-ring construction, balanced piston design and other valve options, see the type numbering system on pages 10 and 11.
2. Outlet pressure for temperatures above 38°C should not exceed the rating in ANSI B16.5.
3. For applications above 538°C, consult the Farris Factory.

Q Orifice

Metric Units, API Area: 7129 mm ² , Actual Area: 7916 mm ²															
Type Number		Valve Size	ANSI Flange Class		Maximum Set Pressure, barg						Back Pressure Limit barg @ 38°C		Material		Inlet Temp. Range
Conventional	BalanSeal	Inlet Outlet	Inlet RF or RJ	Outlet RF	-268°C -60°C	-59°C -30°C	-29°C +38°C	+232°C	+427°C	+538°C	Conventional Type	Balan-Seal Type	Body & Bonnet	Spring	
26QA10	26QB10	6 x 8	150#	150#			11.4	11.4	5.5		7.9	4.8	Carbon Steel	Chrome Alloy	-29°C to 427°C
26QA11	26QB11	6 x 8	300#	150#			11.4	11.4	11.4		7.9	4.8			
26QA12	26QB12	6 x 8	300#	150#			20.7	20.7	20.7		7.9	7.9			
26QA13	26QB13	6 x 8	600#	150#			41.3	41.3	41.3		7.9	7.9			
H26QA13	H26QB13	6 x 8	600#	150#			62.0	62.0	56.8		19.6	13.8			
26QA32	26QB32	6 x 8	300#	150#				11.4	11.4		7.9	4.8	Chrome Moly Steel	High Temp. Alloy	428°C to 538°C
26QA33	26QB33	6 x 8	600#	150#				41.3	30.6		7.9	4.8			
H26QA33	H26QB33	6 x 8	600#	150#				62.0	30.7		19.6	13.8			
26QA10/S3	26QB10/S3	6 x 8	150#	150#		11.4					7.9	4.8	316 St. St.	Chrome Alloy Nickel Plated	-30°C to -59°C
26QA11/S3	26QB11/S3	6 x 8	300#	150#		11.4					7.9	4.8			
26QA12/S3	26QB12/S3	6 x 8	300#	150#		20.7					7.9	7.9			
26QA13/S3	26QB13/S3	6 x 8	600#	150#		41.3					7.9	7.9			
26QA10/S4	26QB10/S4	6 x 8	150#	150#	11.4						7.9	4.8	316 St. St.	316 St. St.	-60°C to -268°C
26QA11/S4	26QB11/S4	6 x 8	300#	150#	11.4						7.9	4.8			
26QA12/S4	26QB12/S4	6 x 8	300#	150#	17.2						7.9	7.9			
26QA13/S4	26QB13/S4	6 x 8	600#	150#	20.7						7.9	7.9			

Selection Chart

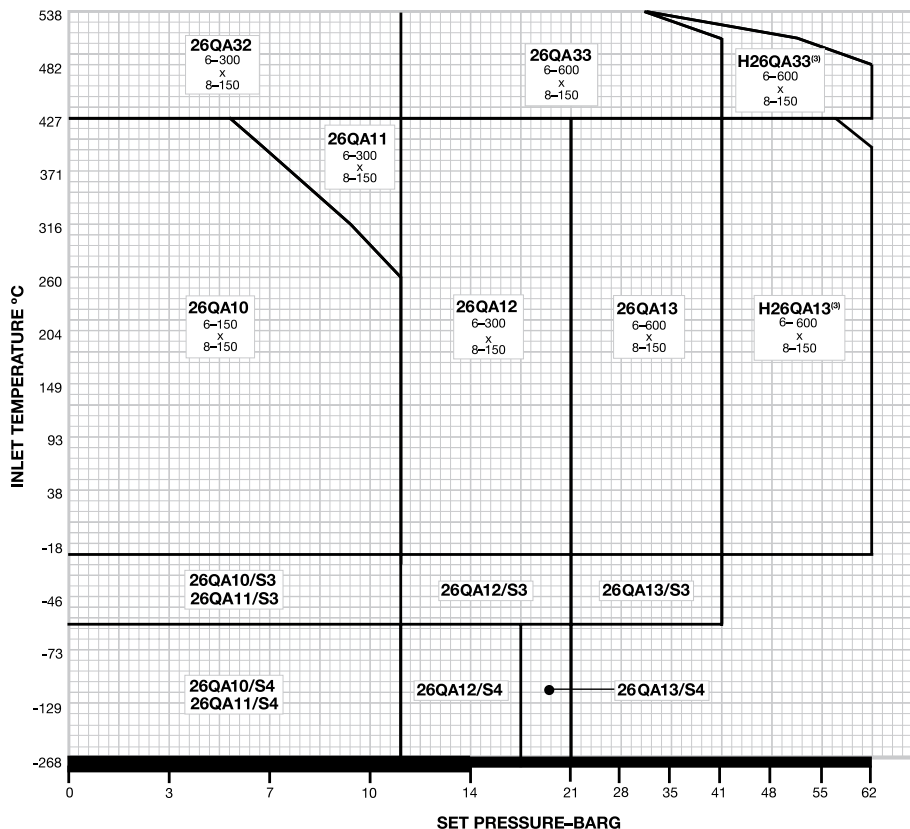

General Notes:

1. The type numbers shown on the selection chart indicate conventional valves. For BalanSeal, O-ring construction, balanced piston design and other valve options, see the type numbering system on pages 10 and 11.
2. Outlet pressure for temperatures above 38°C should not exceed the rating in ANSI B16.5.
3. For applications above 538°C, consult the Farris Factory.

R Orifice

Metric Units, API Area: 10323 mm ² , Actual Area: 11471 mm ²															
Type Number		Valve Size	ANSI Flange Class		Maximum Set Pressure, barg						Back Pressure Limit barg @ 38°C		Material		Inlet Temp. Range
Conventional	BalanSeal	Inlet Outlet	Inlet RF or RJ	Outlet RF	-268°C -60°C	-59°C -30°C	-29°C +38°C	+232°C	+427°C	+538°C	Conventional Type	Balan-Seal Type	Body & Bonnet	Spring	
26RA10	26RB10	6 x 8	150#	150#			6.9	6.9	5.5		4.1	4.1	Carbon Steel	Chrome Alloy	-29°C to 427°C
26RA11	26RB11	6 x 8	300#	150#			6.9	6.9	6.9		4.1	4.1			
26RA12	26RB12	6 x 10	300#	150#			15.8	15.8	15.8		6.9	6.9			
26RA13	26RB13	6 x 10	600#	150#			20.7	20.7	20.7		6.9	6.9			
H26RA13	H26RB13	6 x 10	600#	150#			41.3	41.3	41.3		19.6	13.8			
26RA32	26RB32	6 x 8	300#	150#					6.9	6.8	4.1	4.1	Chrome Moly Steel	High Temp. Alloy	428°C to 538°C
26RA33	26RB33	6 x 10	600#	150#					20.7	20.7	6.9	6.9			
H26RA33	H26RB33	6 x 10	600#	150#					41.3	30.7	19.6	13.8			
26RA10/S3	26RB10/S3	6 x 8	150#	150#		6.9					4.1	3.8	316 St. St.	Chrome Alloy Nickel Plated	-30°C to -59°C
26RA11/S3	26RB11/S3	6 x 8	300#	150#		6.9					4.1	3.8			
26RA12/S3	26RB12/S3	6 x 10	300#	150#		15.8					6.9	6.9			
26RA13/S3	26RB13/S3	6 x 10	600#	150#		20.7					6.9	6.9			
26RA10/S4	26RB10/S4	6 x 8	150#	150#	3.8						4.1	3.8	316 St. St.	316 St. St.	-60°C to -268°C
26RA11/S4	26RB11/S4	6 x 8	300#	150#	3.8						4.1	3.8			
26RA12/S4	26RB12/S4	6 x 10	300#	150#	10.3						6.9	6.9			
26RA13/S4	26RB13/S4	6 x 10	600#	150#	13.8						6.9	6.9			

Selection Chart

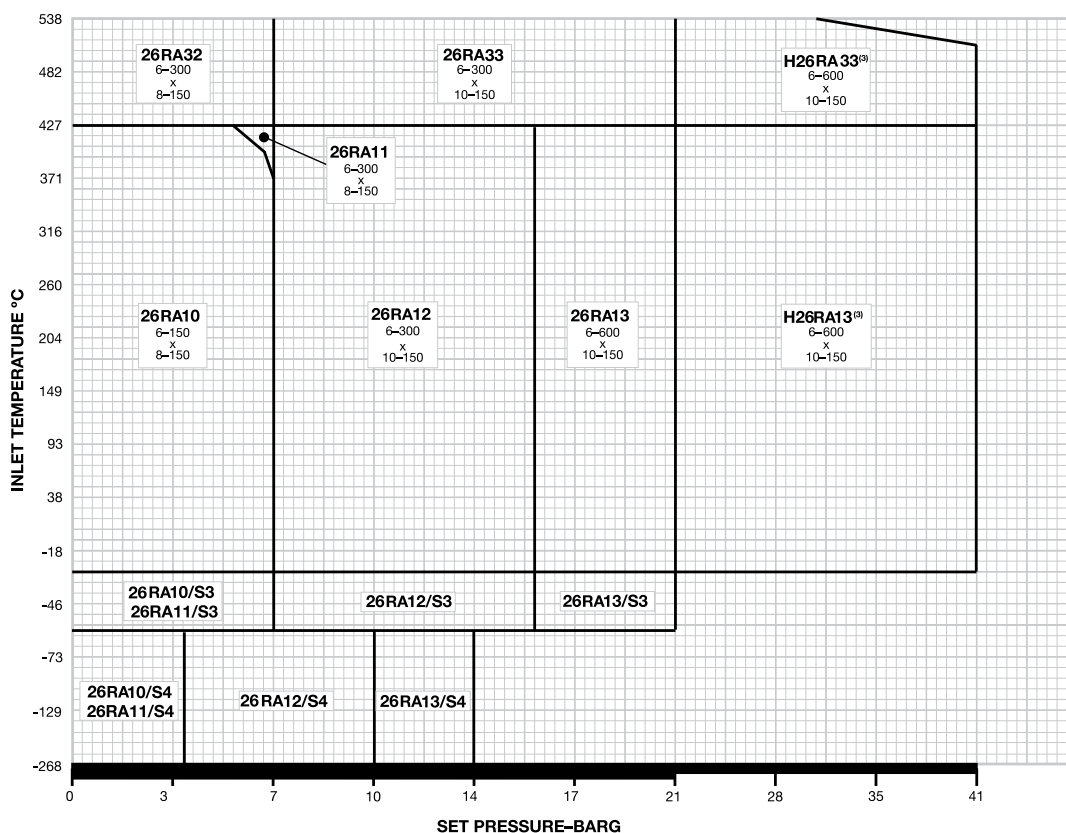

General Notes:

1. The type numbers shown on the selection chart indicate conventional valves. For BalanSeal, O-ring construction, balanced piston design and other valve options, see the type numbering system on pages 10 and 11.
2. Outlet pressure for temperatures above 38°C should not exceed the rating in ANSI B16.5.
3. For applications above 538°C, consult the Farris Factory.

T Orifice

Metric Units, API Area: 16774 mm ² , Actual Area: 18671 mm ²															
Type Number		Valve Size	ANSI Flange Class		Maximum Set Pressure, barg						Back Pressure Limit barg @ 38°C		Material		Inlet Temp. Range
Conventional	BalanSeal	Inlet Outlet	Inlet RF or RJ	Outlet RF	-268°C -60°C	-59°C -30°C	-29°C +38°C	+232°C	+427°C	+538°C	Conventional Type	Balan-Seal Type	Body & Bonnet	Spring	
26TA10	26TB10	8 x 10	150#	150#			4.5	4.5	4.5		2.1	2.1	Carbon Steel	Chrome Alloy	-29°C to 232°C
26TA11	26TB11	8 x 10	300#	150#			4.5	4.5	4.5		2.1	2.1			
26TA12	26TB12	8 x 10	300#	150#			8.3	8.3	8.3		4.1	4.1			
H26TA12	H26TB12	8 x 10	300#	150#			20.7	20.7	20.7		6.9	6.9			
26TA32	26TB32	8 x 10	300#	150#					8.3	8.2	4.1	4.1	Chrome Moly Steel	High Temp. Alloy	428°C to 538°C
H26TA32	H26TB32	8 x 10	300#	150#					20.7	15.5	6.9	6.9			
26TA10/S3	26TB10/S3	8 x 10	150#	150#		4.5					2.1	2.1	316 St. St.	Chrome Alloy Nickel Pltd.	-30°C to -59°C
26TA11/S3	26TB11/S3	8 x 10	300#	150#		4.5					2.1	2.1			
26TA12/S3	26TB12/S3	8 x 10	300#	150#		8.3					4.1	4.1			
26TA10/S4	26TB10/S4	8 x 10	150#	150#	3.4						2.1	2.1	316 St. St.	316 St. St.	-60°C to -268°C
26TA11/S4	26TB11/S4	8 x 10	300#	150#	3.4						2.1	2.1			
26TA12/S4	26TB12/S4	8 x 10	300#	150#	4.5						4.1	4.1			

Selection Chart

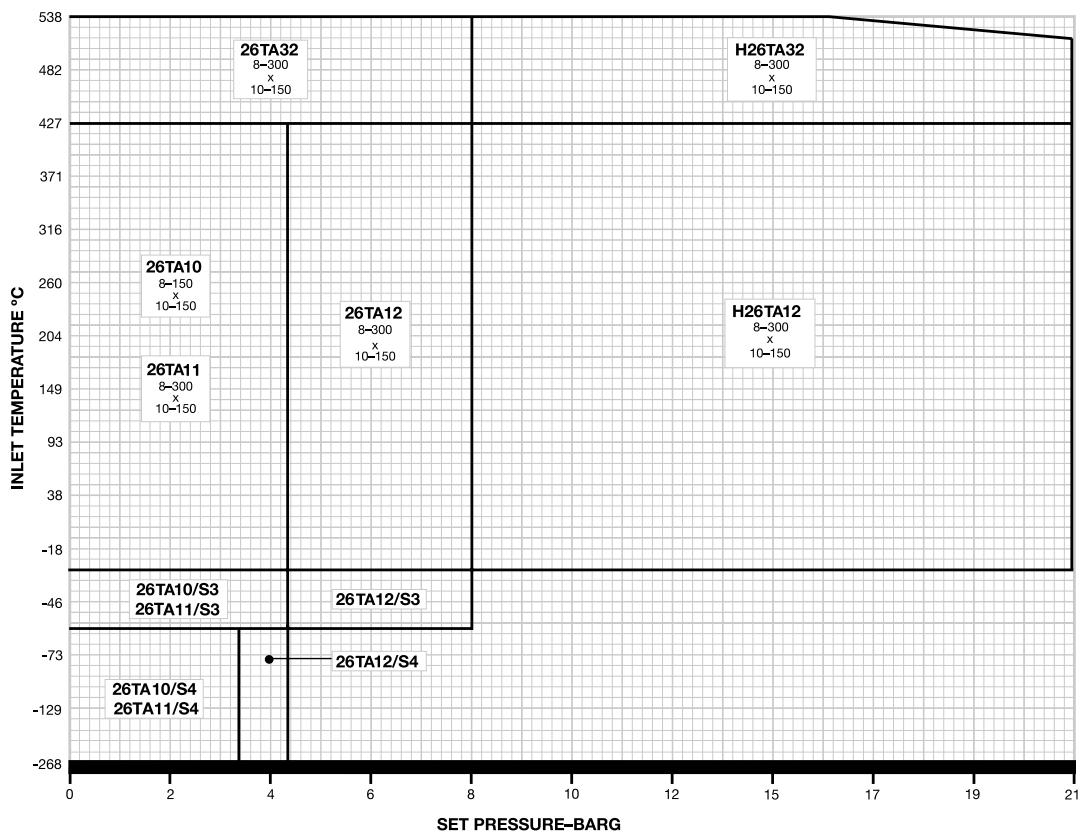

General Notes:

1. The type numbers shown on the selection chart indicate conventional valves. For BalanSeal, O-ring construction, balanced piston design and other valve options, see the type numbering system on pages 10 and 11.
2. Outlet pressure for temperatures above 38°C should not exceed the rating in ANSI B16.5.
3. For applications above 538°C, consult the Farris Factory.

Air Capacities – 2600 Series: 10% Overpressure, API

ASME Pressure Vessel Code (UV), Capacities in Standard Cubic Meters Per Minute at 15.6°C														
Set Pressure (barg)	Orifice Letter Designation & Areas, mm ²													
Areas	D	E	F	G	H	J	K	L	M	N	P	Q	R	T
API	71	126	198	325	506	830	1186	1841	2323	2800	4116	7129	10323	16774
Actual	97	145	239	361	563	923	1317	2045	2581	3111	4572	7916	11471	18671
1	2.1	3.2	5.3	8.0	12.5	20.5	29.2	45.4	57.3	69.1	101	176	255	415
2	3.1	4.6	7.7	11.6	18.1	29.7	42.5	65.9	83.2	100	147	255	370	602
3	4.1	6.2	10.3	15.5	24.3	39.8	56.9	88.3	111	134	197	342	495	806
4	5.2	7.8	12.9	19.5	30.5	50.0	71.4	110	139	168	247	429	622	1012
5	6.3	9.4	15.6	23.5	36.7	60.2	85.9	133	168	203	298	516	748	1218
6	7.3	11.0	18.2	27.5	42.9	70.3	100	156	196	237	348	603	875	1424
7	8.4	12.6	20.8	31.4	49.1	80.5	115	178	225	271	399	691	1001	1630
8	9.0	14.2	23.5	35.4	55.3	90.7	129	201	253	305	449	778	1127	1835
9	10.5	15.8	26.1	39.4	61.5	100	144	223	282	340	499	865	1254	2041
10	11.6	17.4	28.8	43.4	67.7	111	158	246	310	374	550	952	1380	2247
12	13.7	20.6	34.0	51.3	80.2	131	187	291	367	443	651	1127	1633	2659
14	15.9	23.8	39.3	59.3	92.6	151	216	336	424	511	751	1301	1886	3070
16	18.0	27.0	44.6	67.2	105	172	245	381	481	580	852	1476	2139	3482
18	20.1	30.2	49.9	75.2	117	192	274	426	538	648	953	1650	2392	3893
20	22.3	33.4	55.1	83.1	129	212	303	471	595	717	1054	1825	2645	4305
22	24.4	36.6	60.4	91.1	142	233	332	516	651	785	1155	1999	2898	
24	26.5	39.8	65.7	99.0	154	253	361	561	708	854	1255	2174	3150	
26	28.7	43.0	71.0	107	167	273	390	606	765	923	1356	2348	3403	
28	30.8	46.2	76.2	114	179	294	419	651	822	991	1457	2523	3656	
30	32.9	49.4	81.5	122	191	314	448	697	879	1060	1558	2697	3909	
32	35.1	52.6	86.8	130	204	334	478	742	936	1128	1659	2872	4162	
34	37.2	55.8	92.1	138	216	355	507	787	993	1197	1759	3046	4415	
36	39.3	59.0	97.4	146	229	375	536	832	1050	1266	1860	3221	4668	
38	41.5	62.2	102	154	241	395	565	877	1107	1334	1961	3395	4920	
40	43.6	65.4	107	162	254	416	594	922	1163	1403	2062	3570	5173	
42	45.7	68.6	113	170	266	436	623	967	1220	1471	2163	3745		
44	47.9	71.8	118	178	278	456	652	1012	1277	1540	2263	3919		
46	50.0	75.0	123	186	291	477	681	1057	1334	1608	2364	4094		
48	52.1	78.2	129	194	303	497	710	1102	1391	1677	2465	4268		
50	54.3	81.4	134	202	316	517	739	1147	1448	1746	2566	4443		
60	64.9	97.4	160	242	378	619	884	1373	1732	2088	3070	5315		
70	75.6	113	187	281	440	721	1029	1598	2017					
80	86.3	129	213	321	502	822	1175	1824						
90	96.9	145	239	361	564	924	1320	2049						
100	107	161	266	401	626	1026	1465	2274						
110	118	177	292	440	688	1127	1610							
120	128	193	319	480	750	1229	1755							
130	139	209	345	520	812	1331	1901							
140	150	225	371	560	874	1433	2046							
150	160	241	398	599	936	1534	2191							
160	171	257	424	639	999	1636								
170	182	273	450	679	1061	1738								
180	192	289	477	719	1123	1839								
190	203	305	503	758										
200	214	321	530	798										
210	224	337	556	838										
220	235	353	582	878										
230	246	369	609	917										
240	256	385	635	957										
250	267	401	661	997										
260	278	417	688											
270	288	433	714											
280	299	449	741											
290	310	465	767											
300	320	481	793											
310	331	497	820											
320	342	513	846											
330	352	529	873											
340	363	545	899											
350	374	561												
360	384	577												
370	395	593												
380	406	609												
390	416	625												
400	427	641												
410	438	657												

General Notes:
 1. Above capacities should also be used for 2600L series when used in air service.
 2. Capacities at 2.0 barg set pressure and below are based on 0.2 Bar overpressure.
 3. For sizing purposes the effective coefficient of discharge K_e for air, gas, and steam is 0.953 when sizing using the API effective areas. When sizing using the ASME actual areas, the certified coefficient of discharge K for air, gas, and steam service is 0.858.



Steam Capacities, 10% Overpressure

ASME Pressure Vessel Code (UV), Capacities in Kilograms Per Hour at Saturation Temperature														
Set Pressure (barg)	Orifice Letter Designation & Areas, mm ²													
AREAS	D	E	F	G	H	J	K	L	M	N	P	Q	R	T
API	71	126	198	325	506	830	1186	1841	2323	2800	4116	7129	10323	16774
Actual	97	145	239	361	563	923	1317	2045	2581	3111	4572	7916	11471	18761
1	96	145	239	360	563	923	1318	2046	2582	3113	4575	7922	11479	18685
2	140	210	347	523	817	1339	1912	2968	3746	4516	6637	11491	16652	27104
3	188	282	465	701	1095	1794	2561	3977	5018	6049	8891	15394	22307	36308
4	236	354	584	880	1374	2251	3215	4991	6298	7592	11159	19320	27996	45569
5	284	426	702	1059	1653	2709	3868	6005	7578	9135	13427	23246	33686	54829
6	332	498	821	1237	1933	3166	4522	7020	8858	10678	15694	27173	39375	64090
7	380	570	940	1416	2212	3624	5175	8034	10138	12221	17962	31099	45064	73351
8	428	642	1059	1595	2492	4082	5829	9049	11418	13764	20230	35025	50754	82611
9	476	714	1177	1774	2771	4539	6482	10063	12698	15307	22498	38952	56443	91872
10	524	786	1296	1953	3050	4997	7135	11077	13978	16850	24766	42878	62133	101132
11	572	858	1415	2132	3330	5454	7789	12092	15258	18393	27033	46804	67822	110393
12	620	930	1533	2311	3609	5912	8442	13106	16538	19936	29301	50731	73512	119654
13	668	1002	1652	2490	3888	6370	9096	14120	17818	21479	31569	54657	79201	128914
14	716	1074	1771	2668	4168	6827	9749	15135	19098	23022	33837	58583	84891	138175
15	764	1146	1890	2847	4447	7285	10403	16149	20378	24565	36104	62509	90580	147435
16	812	1218	2008	3026	4726	7742	11056	17164	21658	26108	38372	66436	96270	156696
17	860	1290	2127	3205	5006	8200	11709	18178	22938	27651	40640	70362	101959	165957
18	908	1362	2246	3384	5285	8657	12363	19192	24218	29194	42908	74288	107649	175217
19	956	1434	2364	3563	5564	9115	13016	20207	25498	30737	45176	78215	113338	184478
20	1004	1506	2483	3742	5844	9573	13670	21221	26778	32280	47443	82141	119028	193738
22	1100	1650	2721	4099	6403	10488	14977	23250	29337	35366	51979	89994	130407	
24	1196	1794	2958	4457	6961	11403	16283	25279	31897	38452	56515	97846	141786	
26	1292	1938	3195	4815	7520	12318	17590	27307	34457	41538	61050	105699	153165	
28	1388	2082	3433	5173	8079	13233	18897	29336	37017	44624	65586	113552	164544	
30	1484	2226	3670	5530	8637	14149	20204	31365	39577	47710	70121	121404	175923	
32	1580	2370	3908	5888	9196	15064	21511	33394	42137	50796	74657	129257	187302	
34	1676	2514	4145	6246	9755	15979	22818	35422	44697	53883	79193	137110	198681	
36	1772	2658	4383	6604	10313	16894	24125	37451	47257	56969	83728	144962	210059	
38	1868	2802	4620	6962	10872	17809	25431	39480	49817	60055	88264	152815	221438	
40	1964	2946	4858	7319	11431	18724	26738	41509	52377	63141	92799	160667	232817	
42	2060	3090	5095	7677	11990	19640	28045	43537	54937	66227	97335	168520		
44	2156	3234	5332	8035	12548	20555	29352	45566	57497	69313	101870	176373		
46	2252	3378	5570	8393	13107	21470	30659	47595	60057	72399	106406	184225		
48	2348	3522	5807	8750	13666	22385	31966	49624	62617	75485	110942	192078		
50	2444	3666	6045	9108	14224	23300	33272	51652	65177	78571	115477	199931		
52	2540	3810	6282	9466	14783	24216	34579	53681	67737	81657	120013	207783		
54	2636	3954	6520	9824	15342	25131	35886	55710	70297	84743	124548	215636		
56	2732	4098	6757	10181	15901	26046	37193	57739	72857	87829	129084	223489		
58	2828	4242	6994	10539	16459	26961	38500	59767	75417	90915	133620	231341		
60	2924	4386	7232	10897	17018	27876	39807	61796	77976	94001	138155	239194		
62	3020	4530	7469	11255	17577	28791	41114	63825	80536	97087	142691	247046		
64	3116	4674	7707	11612	18135	29707	42420	65854	83096	100173	147226			
66	3212	4818	7944	11970	18694	30622	43727	67883	85656	103259	151762			
68	3308	4962	8182	12328	19253	31537	45034	69911	88216	106345	156298			
70	3404	5106	8419	12686	19812	32452	46341	71940	90776					
72	3500	5250	8656	13043	20370	33367	47648	73969	93336					
74	3596	5394	8894	13401	20929	34283	48955	75998	95896					
76	3692	5538	9131	13759	21488	35198	50262	78026						
78	3788	5682	9369	14117	22046	36113	51568	80055						
80	3884	5826	9606	14474	22605	37028	52875	82084						
82	3980	5970	9844	14832	23164	37943	54182	84113						
84	4076	6114	10081	15190	23722	38858	55489	86141						
86	4172	6258	10319	15548	24281	39774	56796	88170						
88	4268	6402	10556	15905	24840	40689	58103	90199						
90	4364	6546	10793	16263	25399	41604	59410	92228						
92	4460	6690	11031	16621	25957	42519	60716	94256						
94	4556	6834	11268	16979	26516	43434	62023	96285						
96	4652	6978	11506	17336	27075	44350	63330	98314						
98	4748	7122	11743	17694	27633	45265	64637	100343						
100	4844	7266	11981	18052	28192	46180	65944	102371						
110	5324	7986	13168	19841	30986	50756	72478							
120	5804	8706	14355	21629	33779	55332	79012							
130	6284	9426	15542	23418	36573	59908	85547							
140	6764	10146	16729	25207	39366	64484	92081							
150	7244	10866	17916	26996	42160	69059	98615							
160	7724	11586	19104	28784	44953	73635								
170	8204	12306	20291	30573	47747	78211								
180	8684	13026	21478	32362	50540	82787								
190	9164	13746	22665	34151										
200	9643	14465	23852	35939										

General Notes:
 1. Above capacities should also be used for 2600L series when used in steam service.
 2. Capacities at 2.0 barg set pressure and below are based on 0.2 Bar overpressure.
 3. For sizing purposes the effective coefficient of discharge K_d for air, gas, and steam is 0.953 when sizing using the API effective areas. When sizing using the ASME actual areas, the certified coefficient of discharge K for air, gas, and steam service is 0.858.

Water Capacities – 2600L, 10% Overpressure

ASME Pressure Vessel Code (UV), Capacities in Liters Per Minute at 21°C														
Set Pressure (barg)	Orifice Letter Designation & Areas, mm ²													
Areas	D	E	F	G	H	J	K	L	M	N	P	Q	R	T
API	71	126	198	325	506	830	1186	1841	2323	2800	4116	7129	10323	16774
Actual	97	145	239	361	563	923	1317	2045	2581	3111	4572	7916	11471	18761
1	58.8	88.2	145	219	342	561	801	1244	1569	1892	2781	4815	6977	11357
2	79.6	119	196	296	463	758	1083	1682	2122	2559	3761	6511	9435	15358
3	97.3	146	240	362	566	928	1325	2057	2595	3129	4599	7962	11538	18781
4	112	168	278	418	654	1071	1530	2375	2997	3613	5310	9194	13323	21686
5	125	188	310	468	731	1198	1710	2655	3351	4040	5937	10280	14896	24246
6	137	206	340	513	801	1312	1874	2909	3671	4425	6504	11261	16318	26561
7	148	223	367	554	865	1417	2024	3142	3965	4780	7025	12163	17625	28689
8	158	238	393	592	925	1515	2164	3359	4239	5110	7510	13003	18842	30670
9	168	252	417	628	981	1607	2295	3563	4496	5420	7966	13792	19985	32530
10	177	266	439	662	1034	1694	2419	3756	4739	5713	8397	14538	21066	34290
12	194	292	481	725	1133	1856	2650	4114	5191	6258	9198	15925	23077	37562
14	210	315	520	783	1223	2004	2862	4444	5607	6760	9935	17202	24926	40572
16	224	337	556	837	1308	2143	3060	4751	5995	7226	10621	18389	26647	43373
18	238	357	589	888	1387	2273	3246	5039	6358	7665	11265	19505	28264	46005
20	251	377	621	936	1462	2396	3421	5311	6702	8080	11875	20560	29793	
22	263	395	652	982	1534	2513	3588	5571	7029	8474	12455	21563	31247	
24	275	413	681	1026	1602	2624	3748	5818	7342	8851	13008	22522	32636	
26	286	429	708	1067	1667	2732	3901	6056	7642	9212	13540	23442	33969	
28	297	446	735	1108	1730	2835	4048	6285	7930	9560	14051	24327	35251	
30	307	461	761	1147	1791	2934	4190	6505	8209	9895	14544	25181	36489	
32	317	476	786	1184	1850	3030	4328	6719	8478	10220	15021	26006		
34	327	491	810	1221	1907	3124	4461	6925	8739	10535	15483	26807		
36	337	505	834	1256	1962	3214	4590	7126	8992	10840	15932	27584		
38	346	519	856	1291	2016	3302	4716	7321	9238	11137	16369	28340		
40	355	533	879	1324	2068	3388	4839	7512	9478	11426	16794	29076		
42	364	546	900	1357	2119	3472	4958	7697	9713	11709	17209	29794		
44	372	559	922	1389	2169	3554	5075	7878	9941	11984	17614			
46	381	571	942	1420	2218	3634	5189	8055	10165	12253	18009			
48	389	584	963	1451	2266	3712	5300	8229	10383					
50	397	596	982	1481	2312	3788	5410	8398	10597					
60	435	653	1076	1622	2533	4150	5926	9200						
70	470	705	1163	1752	2736	4482	6401	9937						
80	502	754	1243	1873	2925	4792	6843	10623						
90	533	799	1318	1987	3103	5083	7258	11268						
100	562	843	1390	2094	3271	5358	7651	11877						
110	589	884	1457	2196	3430	5619	8024	12457						
120	615	923	1522	2294	3583	5869	8381	13011						
130	640	961	1584	2388	3729	6109	8723	13542						
140	665	997	1644	2478	3870	6339	9052							
150	688	1032	1702	2565	4006	6562	9370							
160	710	1066	1758	2649	4137	6777	9678							
170	732	1099	1812	2730	4264	6986	9975							
180	754	1131	1865	2810	4388	7188	10265							
190	774	1162	1916	2887	4508	7385	10546							
200	794	1192	1965	2962	4625	7577	10820							
210	814	1221	2014	3035	4740	7764	11087							
220	833	1250	2061	3106	4851	7947	11348							
230	852	1278	2108	3176	4960	8125	11603							
240	870	1306	2153	3244	5067	8300	11853							
250	888	1332	2197	3311	5171	8471								
260	906	1359	2241	3377	5274	8639								
270	923	1385	2284	3441	5374	8804								
280	940	1410	2326	3504	5473	8965								
290	957	1435	2367	3566	5570	9124								
300	973	1460	2407	3627										
310	989	1484	2447	3687										
320	1005	1508	2486	3746										
330	1020	1531	2525	3804										
340	1036	1554	2563	3862										
350	1051	1577	2600											
360	1066	1599	2637											
370	1081	1621	2673											
380	1095	1643												
390	1109	1664												
400	1124	1686												
410	1138	1707												

General Notes:
 1. Capacities at 2.0 barg set pressure and below are based on 0.2 Bar overpressure.
 2. For sizing purposes the effective coefficient of discharge K_d for liquids is 0.724 when sizing using the API effective areas. When sizing using the ASME actual areas, the certified coefficient of discharge K for water is 0.652.



Water Capacities – 2600: 25% Overpressure

Non-Code, Capacities in Liters Per Minute at 21°C														
Set Pressure (barg)	Orifice Letter Designation & Areas, mm ²													
AREAS	D	E	F	G	H	J	K	L	M	N	P	Q	R	T
API	71	126	198	325	506	830	1186	1841	2323	2800	4116	7129	10323	16774
Actual	97	145	239	361	563	923	1317	2045	2581	3111	4572	7916	11471	18761
1	52.9	79.3	130	197	308	504	720	1118	1411	1701	2500	4329	6273	10211
2	74.8	112	185	278	435	713	1019	1581	1996	2406	3536	6122	8872	14441
3	91.6	137	226	341	533	873	1248	1937	2444	2947	4331	7499	10866	17687
4	105	158	261	394	616	1009	1441	2237	2822	3402	5001	8659	12547	20423
5	118	177	292	441	688	1128	1611	2501	3156	3804	5591	9681	14028	22834
6	129	194	320	483	754	1235	1764	2739	3457	4167	6125	10605	15367	25013
7	140	210	346	521	815	1335	1906	2959	3734	4501	6616	11455	16599	27017
8	149	224	370	557	871	1427	2038	3163	3992	4812	7073	12245	17745	28883
9	158	238	392	591	924	1513	2161	3355	4234	5104	7502	12988	18821	30635
10	167	251	413	623	974	1595	2278	3537	4463	5380	7907	13691	19839	32292
12	183	275	453	683	1067	1747	2496	3874	4889	5894	8662	14998	21733	35374
14	198	297	489	738	1152	1888	2696	4185	5281	6366	9356	16199	23474	38209
16	211	317	523	788	1232	2018	2882	4474	5645	6805	10002	17318	25095	40847
18	224	336	555	836	1306	2140	3057	4745	5988	7218	10609	18368	26617	43325
20	236	355	585	882	1377	2256	3222	5002	6312	7609	11183	19362	28057	
22	248	372	614	925	1444	2366	3379	5246	6620	7980	11729	20307	29427	
24	259	388	641	966	1509	2471	3529	5479	6914	8335	12251	21210	30735	
26	269	404	667	1005	1570	2572	3674	5703	7196	8675	12751	22076	31990	
28	280	420	692	1043	1630	2670	3812	5918	7468	9003	13232	22910	33198	
30	289	434	717	1080	1687	2763	3946	6126	7730	9319	13697	23714	34363	
32	299	449	740	1115	1742	2854	4076	6327	7984	9625	14146	24491		
34	308	462	763	1150	1796	2942	4201	6522	8230	9921	14581	25245		
36	317	476	785	1183	1848	3027	4323	6711	8468	10208	15004	25977		
38	326	489	806	1215	1898	3110	4441	6895	8700	10488	15415	26689		
40	334	502	827	1247	1948	3191	4557	7074	8926	10761	15815	27382		
42	343	514	848	1278	1996	3270	4669	7249	9147	11026	16206	28059		
44	351	526	868	1308	2043	3347	4779	7419	9362	11286	16587			
46	358	538	887	1337	2089	3422	4886	7586	9572	11540	16960			
48	366	550	906	1366	2134	3495	4992	7749	9778					
50	374	561	925	1394	2178	3568	5095	7909	9980					
60	409	614	1014	1527	2386	3908	5581	8664						
70	442	664	1095	1650	2577	4221	6028	9358						
80	473	710	1170	1764	2755	4513	6444	10004						
90	502	753	1241	1871	2922	4786	6835	10611						
100	529	793	1309	1972	3080	5045	7205	11185						
110	555	832	1373	2068	3230	5292	7557	11731						
120	579	869	1434	2160	3374	5527	7893	12253						
130	603	905	1492	2248	3512	5753	8215	12753						
140	626	939	1548	2333	3644	5970	8525							
150	648	972	1603	2415	3772	6179	8824							
160	669	1004	1655	2495	3896	6382	9114							
170	690	1035	1706	2571	4016	6579	9394							
180	710	1065	1756	2646	4132	6769	9667							
190	729	1094	1804	2718	4246	6955	9931							
200	748	1122	1851	2789	4356	7136	10190							
210	767	1150	1897	2858	4464	7312	10441							
220	785	1177	1941	2925	4569	7484	10687							
230	802	1204	1985	2991	4671	7652	10927							
240	819	1229	2028	3055	4772	7817	11162							
250	836	1255	2069	3118	4870	7978								
260	853	1280	2110	3180	4967	8136								
270	869	1304	2151	3241	5061	8291								
280	885	1328	2190	3300	5154	8443								
290	901	1352	2229	3359	5245	8592								
300	916	1375	2267	3416										
310	931	1397	2304	3472										
320	946	1420	2341	3528										
330	961	1442	2378	3583										
340	975	1463	2413	3637										
350	990	1485	2449											
360	1004	1506	2483											
370	1018	1527	2518											
380	1031	1547												
390	1045	1567												
400	1058	1587												
410	1071	1607												

General Notes:
 1. Capacities at 2.0 barg set pressure and below are based on 0.2 Bar overpressure.
 2. For sizing purposes the effective coefficient of discharge K_d for liquids is 0.64 when sizing using the API effective areas. When sizing using the ASME actual areas, the certified coefficient of discharge K for water is 0.576.

2600 Series Super Capacity Pressure Relief Valves

Farris Engineering offers a complete line of large orifice, spring-loaded safety relief valves for applications requiring flows larger than the standard API "T" orifice. These large orifice valves offer the same superior design, construction, metallurgy, and options as the standard 2600 Series. Features include full nozzle, balanced bellows, isolation of bonnet spring chamber, integral one-piece sleeve guide, temperature equalizing disc, and positive connection of internal parts. Six sizes with inlets ranging from 8" to 20" and effective orifice areas from 31.5 to 176.7 square inches are available.

The 2600 Series large orifice valves are offered in both conventional and BalanSeal construction with ANSI Class 300 RF flanged inlet by ANSI Class 150 RF flanged outlet, and temperature range from -20° to 800° F. They are designed and built in accordance with the ASME Boiler and Pressure Vessel Code, Section VIII. Capacity ratings are certified by the National Board of Boiler and Pressure Vessel Inspectors.

Orifice	Actual Orifice Area		Type Number		Valve Size Inlet X Outlet (inches)	Maximum Set Pressure, psig		Maximum Set Pressure, barg		Maximum Back Pressure All Designs	
	Square Inches	Square Centimeters	Conventional	BalanSeal		-20°F to +450°F	+451°F to +800°F	-29°C to +232°C	+233°C to +427°C	psig @ 100°F	barg @ 38°C
U	31.5	203.2	26UA10	26UB10	8 x 10	65	65	4.5	4.5	30	2.1
			26UA11	26UB11		65	65	4.5	4.5	30	2.1
			26UA12	26UB12		120	120	8.3	8.3	60	4.1
			H26UA12	H26UB12		300	300	20.7	20.7	100	6.9
W	63.6	410.2	26WA12	26WB12	12 x 16	300	300	20.7	20.7	100	6.9
W2	104.0	670.8	26W2A12	26W2B12	16 x 18	300	300	20.7	20.7	100	6.9
X	113.1	729.5	26XA12	26XB12	16 x 20	300	300	20.7	20.7	100	6.9
Y	143.1	923.0	26YA12	26YB12	18 x 24	300	300	20.7	20.7	100	6.9
Z	176.7	1139.7	26ZA12	26ZB12	20 x 24	300	200	20.7	13.8	100	6.9

Materials of Construction: Carbon steel body and bonnet, stainless steel trim and chrome alloy spring. Other materials available on application. Consult the factory.

Connections: ANSI Class 300#RF inlet x 150#RF. Other connection types available on application. Consult the factory.

General Notes:

1. All valves supplied with plain caps unless otherwise specified. Standard suffix for type number is "-120". For other cap construction, refer to page 69.
2. For set pressures under 20 psig (1.4 barg) consult the factory.
3. ASME Boiler and Pressure Vessel Code Section VIII requires all valves have a lifting lever when used for air, steam and hot water (over 140°F).
4. For corrosive, low and high temperature materials, ANSI Class 150 inlet flange and open bonnet designs, consult the Factory.
5. Standard flange finish is serrated unless otherwise specified.
6. Optional equipment includes: air set device for set pressure testing, extra large lapping glass for valve seat maintenance, spring compression device for set pressure adjustment, and special disassembly and reassembly equipment.
7. The "U" orifice with 300# inlet flange is available up to 1000°F. Set pressures are the same as the comparable "T" orifice.

2600 Series Super Capacity Conventional

Bill of Materials—Conventional		
Item	Part Name	Material
1	Body 26()A12	ASTM A216 Gr. WCB. Carb. St.
2	Bonnet 26()A12	ASTM A216 Gr. WCB. Carb. St.
3	Cap, Plain Screwed	ASTM A216 Gr. WCB. Carb. St.
4	Disc	Stainless Steel
5	Nozzle	316 St. St.
6	Disc Holder	Stainless Steel
7	Blowdown Ring	Stainless Steel
8	Sleeve Guide 26()A12	Stainless Steel
9	Stem	Stainless Steel
10	Spring Adjusting Screw	Stainless Steel
11	Jam Nut (Spr. Adj. Screw)	Stainless Steel
12	Lock Screw (B.D.R.)	Stainless Steel
13	Lock Screw Stud	Stainless Steel
14	Stem Retainer	Stainless Steel
15	Spring Button, Lower	Carbon St. Rust Proofed
16	Spring Button, Upper	Carbon St. Rust Proofed
17*	Insert, Spring Button Upper	Stainless Steel
18	Stem Insert	Stainless Steel
19*	Retaining Ring	Stainless Steel
20*	Back-Up Ring	Teflon
21*	Cylinder Plug	Stainless Steel
22*	O-Ring, Cylinder Plug	Ethylene Propylene
23	Body Stud	ASTM A193 Gr. B7, Alloy St.
24	Hex Nut (Body)	ASTM A194 Gr. 2H, Alloy St.
25	Spring 26()A12	Chrome Alloy, Rust Proofed
26*	Roller Thrust Bearing	Hardened Alloy Steel
27	Cap Gasket	Soft Iron or Steel
28	Body Gasket	Soft Iron or Steel
29	Bonnet Gasket	Soft Iron or Steel
30	Lock Screw Gasket	Soft Iron or Steel
31	Hex Nut (B.D.R.L.S.)	Stainless Steel
32	Lock Screw (D.H.)	Stainless Steel
33	Pipe Plug (Bonnet)	Steel
34	Pipe Plug (Body)	Steel
35*	Forged Eye Bolt	Steel, Galvanized

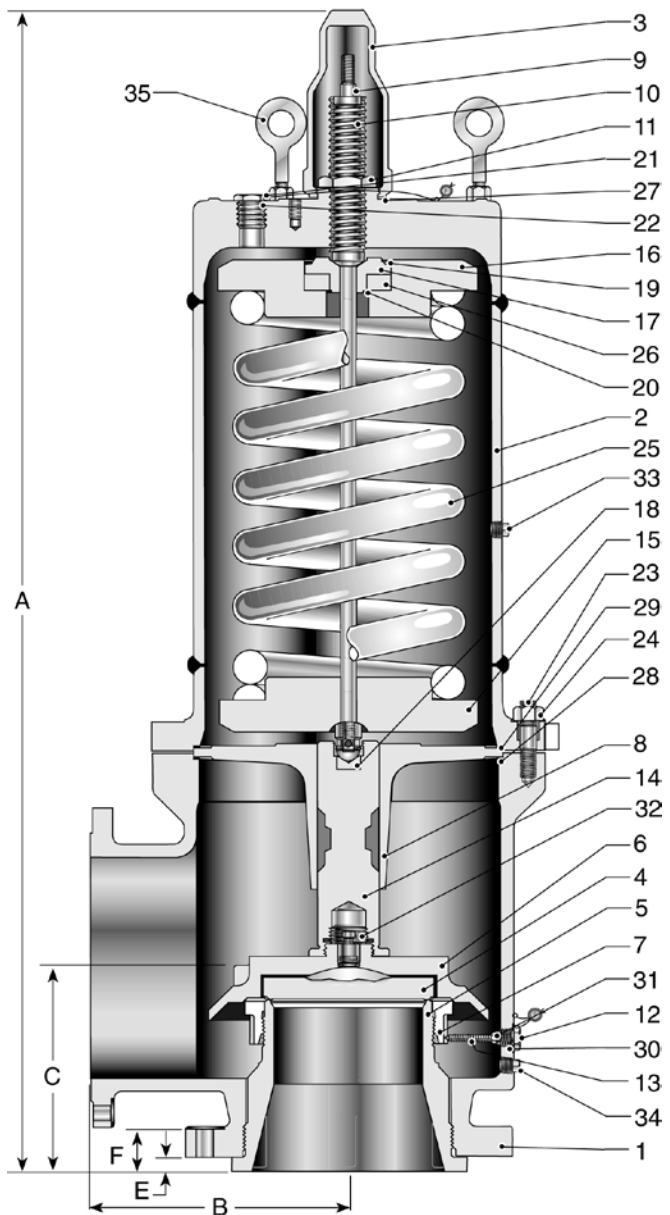

*Not supplied on U & W orifice

Valve Size Inlet X Outlet	ANSI Flange Class		Type Number Conv.	Dimensions, in/mm					Approx. Weight Lbs/Kg
	Inlet RF	Outlet RF		A (max.)	B	C	E	F	
8 U 10	300	150	26UA12	54-1/2 1385	11 279	10-7/8 276	13/16 21	2-7/16 62	650 295
12 W 16	300	150	26WA12	70-1/2 1791	16 406	14-1/8 359	13/16 21	2-13/16 71	2800 1270
16 W2 18	300	150	26W2A12	90-3/4 2305	20 508	16 406	1-1/4 32	3-1/2 89	4200 1905
16 X 20	300	150	26XA12	93-1/2 2375	21 533	17 432	1-1/4 32	3-1/2 89	5500 2495
18 Y 24	300	150	26YA12	97-1/2 2477	25 635	20 508	1-1/4 32	3-5/8 92	7000 3175
20 Z 24	300	150	26ZA12	109 2769	25 635	20 508	1-1/4 32	3-3/4 95	7500 3402

Note: The "U" orifice weights and dimensions are identical to the "T" orifice on page 75.

2600 Series Super Capacity BalanSeal

Bill of Materials—BalanSeal		
Item	Part Name	Material
1	Body 26()B12	ASTM A216 Gr. WCB. Carb. St.
2	Bonnet 26()B12	ASTM A216 Gr. WCB. Carb. St.
3	Cap, Plain Screwed	ASTM A216 Gr. WCB. Carb. St.
4	Disc	Stainless Steel
5	Nozzle	316 St. St.
6	Disc Holder	Stainless Steel
7	Blowdown Ring	Stainless Steel
8	Sleeve Guide 26()B12	Stainless Steel
9	Stem	Stainless Steel
10	Spring Adjusting Screw	Stainless Steel
11	Jam Nut (Spr. Adj. Screw)	Stainless Steel
12	Lock Screw (B.D.R.)	Stainless Steel
13	Lock Screw Stud	Stainless Steel
14	Stem Retainer	Stainless Steel
15	Spring Button, Lower	Carbon St. Rust Proofed
16	Spring Button, Upper	Carbon St. Rust Proofed
17*	Insert, Spring Button Upper	Stainless Steel
18	Stem Insert	Stainless Steel
19*	Retaining Ring	Stainless Steel
20*	Back-Up Ring	Teflon
21*	Cylinder Plug	Stainless Steel
22*	O-Ring, Cylinder Plug	Ethylene Propylene
23	Body Stud	ASTM A193 Gr. B7, Alloy St.
24	Hex Nut (Body)	ASTM A194 Gr. 2H, Alloy St.
25	Spring 26()B12	Chrome Alloy, Rust Proofed
26*	Roller Thrust Bearing	Hardened Alloy Steel
27	Cap Gasket	Soft Iron or Steel
28	Body Gasket	Soft Iron or Steel
29	Bonnet Gasket	Soft Iron or Steel
30	Lock Screw Gasket	Soft Iron or Steel
31	Hex Nut (B.D.R.L.S.)	Stainless Steel
32	Lock Screw (D.H.)	Stainless Steel
33	Pipe Plug (Body)	Steel
34	Bellows	Inconel Composite
35*	Bellows Gasket	Flexible Graphite
36*	Forged Eye Bolt	Steel, Galvanized

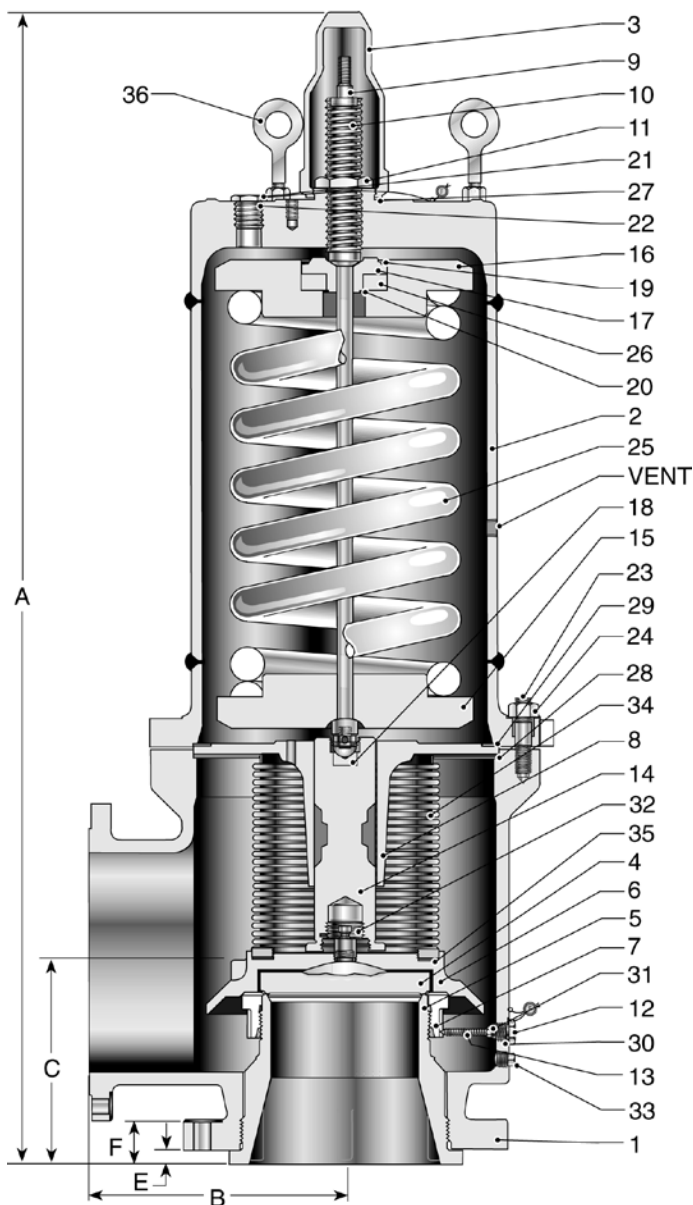

*Not supplied on U & W orifice

Valve Size Inlet X Outlet	ANSI Flange Class		Type Number Conv.	Dimensions, in/mm					Approx. Weight Lbs/Kg
	Inlet RF	Outlet RF		A (max.)	B	C	E	F	
8 U 10	300	150	26UB12	54-1/2	11	10-7/8	13/16	2-7/16	700
				1385	279	276	21	62	317
12 W 16	300	150	26WB12	70-1/2	16	14-1/8	13/16	2-13/16	2850
				1791	406	359	21	71	1293
16 W2 18	300	150	26W2B12	90-3/4	20	16	1-1/4	3-1/2	4250
				2305	508	406	32	89	1927
16 X 20	300	150	26XB12	93-1/2	21	17	1-1/4	3-1/2	5550
				2375	533	432	32	89	2517
18 Y 24	300	150	26YB12	97-1/2	25	20	1-1/4	3-5/8	7050
				2477	635	508	32	92	3197
20 Z 24	300	150	26ZB12	109	25	20	1-1/4	3-3/4	7550
				2769	635	508	32	95	3424

Note: The "U" orifice weights and dimensions are identical to the "T" orifice on page 75.



Air Capacities – 2600 Series Super Capacity: 10% Overpressure, API

ASME Pressure Vessel Code (UV), Capacities In Standard Cubic Feet Per Minute At 60 °F						
Set Pressure (psig)	Orifice Letter Designation & Areas, Sq. Inches					
	U 31.5	W 63.62	W2 104.0	X 113.1	Y 143.1	Z 176.7
20	18677	37723	61666	67062	84850	104773
30	23632	47729	78023	84850	107357	132564
40	29081	58736	96016	104417	132114	163135
50	34531	69742	114009	123984	156872	193705
60	39981	80749	132001	143552	181629	224276
70	45431	91756	149994	163119	206387	254846
80	50880	102763	167987	182686	231144	285417
90	56330	113769	185980	202253	255901	315987
100	61780	124776	203973	221820	280659	346558
125	75404	152293	248955	270738	342552	422984
150	89029	179810	293937	319656	404446	499410
175	102653	207327	338919	368574	466340	575837
200	116277	234844	383901	417492	528233	652263
250	143526	289878	473865	515328	652020	805116
300	170775	344912	563829	613164	775808	957968

Steam Capacities – 2600 Series Super Capacity: 10% Overpressure, API

ASME Pressure Vessel Code (UV), Capacities In Pounds Per Hour At Saturation Temperature						
Set Pressure (psig)	Orifice Letter Designation & Areas, Sq. Inches					
	U 31.5	W 63.62	W2 104.0	X 113.1	Y 143.1	Z 176.7
20	52474	105981	173248	188407	238383	294355
30	66393	134093	219202	238383	238383	372434
40	81703	165016	269752	293356	371169	458320
50	97014	195939	320302	348329	440724	544206
60	112325	226861	370852	403302	510278	630092
70	127636	257784	421402	458275	579833	715979
80	142947	288707	471952	513248	649388	801865
90	158257	319630	522502	568221	718943	887751
100	173568	350553	573052	623194	788498	973638
125	211845	427861	699427	760627	962384	1188353
150	250122	505168	825802	898059	1136271	1403069
175	288399	582475	952176	1035492	1310158	1617785
200	326676	659783	1078551	1172924	1484045	1832500
250	403230	814397	1331301	1447790	1831819	2261932
300	479784	969012	1584050	1722655	2179593	2691363

Water Capacities – 2600 Series Super Capacity: 25% Overpressure, API⁴

Capacities In Gallons Per Minute At 70 °F, Non Code						
Set Pressure (psig)	Orifice Letter Designation & Areas, Sq. Inches					
	U 31.5	W 63.62	W2 104.0	X 113.1	Y 143.1	Z 176.7
20	3742	6962	11381	12377	15660	19337
30	4483	8527	13939	15159	19179	23683
40	5176	9846	16095	17504	22147	27347
50	5787	11008	17995	19570	24761	30575
60	6340	12059	19713	21438	27124	33493
70	6848	13025	21292	23155	29297	36177
80	7320	13924	22762	24754	31320	38674
90	7765	14769	24143	26256	33220	41020
100	8185	15568	25449	27676	35017	43239
125	9151	17405	28453	30943	39150	48343
150	10024	19067	31169	33896	42887	52957
175	10827	20594	33666	36612	46324	57200
200	11575	22016	35991	39140	49522	61150
250	12941	24615	40239	43760	55367	68368
300	14177	26965	44080	47937	60652	74893

General Notes:

1. Capacities at 30 psig and below are based on 3 PSI overpressure.
2. For sizing purposes using the ASME actual areas, the certified coefficient of discharge K for air, gas, and steam service is 0.858.
3. For sizing purposes using the actual areas, the coefficient of discharge K for water is 0.576.
4. The "U" orifice meets the requirements of ASME Code Section VIII. Capacities listed in the table for the "U" orifice are based on 10% overpressure.



Air Capacities – 2600 Series Super Capacity: 10% Overpressure, API – Metric Units

ASME Pressure Vessel Code (UV), Capacities In Standard Cubic Meters Per Minute At 15.6°C						
Set Pressure (barg)	Orifice Letter Designation & Areas, cm ²					
	U 203.2	W 410.2	W2 670.8	X 729.5	Y 923.0	Z 1139.7
1.4	533	1077	1761	1915	2423	2992
2	655	1324	2164	2353	2978	3677
3	878	1773	2899	3153	3989	4926
4	1102	2226	3639	3957	5007	6183
5	1326	2678	4378	4761	6024	7439
6	1550	3131	5118	5566	7042	8696
7	1774	3583	5857	6370	8060	9952
8	1998	4035	6597	7174	9077	11209
9	2222	4488	7336	7978	10095	12465
10	2446	4940	8076	8783	11113	13722
12	2894	5845	9555	10391	13148	16235
14	3342	6750	11034	12000	15183	18748
16	3790	7655	12513	13608	17218	21261
18	4238	8559	13993	15217	19253	23774
20.7	4843	9781	15989	17388	22001	27167

Steam Capacities – 2600 Series Super Capacity: 10% Overpressure, API – Metric Units

ASME Pressure Vessel Code (UV), Capacities In Kilograms Per Hour At Saturation Temperature						
Set Pressure (barg)	Orifice Letter Designation & Areas, cm ²					
	U 203.2	W 410.2	W2 670.8	X 729.5	Y 923.0	Z 1139.7
1.4	24003	48480	79251	86185	109046	134650
2	29501	59584	97403	105926	134023	165492
3	39520	79818	130480	141897	179535	221690
4	49600	100176	163759	178088	225326	278233
5	59679	120534	197038	214279	271117	334776
6	69759	140892	230317	250470	316908	391319
7	79839	161250	263597	286662	362699	447861
8	89919	181608	296876	322853	408490	504404
9	99999	201966	330155	359044	454281	560947
10	110078	222324	363435	395235	500072	617490
12	130238	263040	429993	467618	591654	730576
14	150398	303756	496552	540000	683237	843661
16	170557	344472	563111	612383	774819	956747
18	190717	385188	629669	684765	866401	1069833
20.7	217932	440154	719523	782482	990037	1222498

Water Capacities – 2600 Series Super Capacity: 25% Overpressure, API⁴ – Metric Units

Capacities In Liters Per Minute At 21 °C, Non Code						
Set Pressure (barg)	Orifice Letter Designation & Areas, cm ²					
	U 203.2	W 410.2	W2 670.8	X 729.5	Y 923.0	Z 1139.7
1.4	14264	26562	43421	47220	59745	73774
2	16716	31747	51898	56439	71409	88177
3	20442	38882	63562	69123	87458	107994
4	23605	44898	73395	79817	100988	124701
5	26391	50197	82058	89238	112909	139420
6	28910	54988	89890	97755	123685	152727
7	31226	59394	97092	105588	133595	164964
8	33383	63495	103796	112878	142819	176354
9	35408	67347	110092	119725	151483	187051
10	37323	70990	116047	126202	159677	197169
12	40885	77765	127124	138247	174917	215988
14	44161	83996	137309	149324	188932	233294
16	47210	89796	146790	159634	201977	249402
18	50074	95243	155694	169317	214229	264531
20.7	53699	102136	166963	181573	229735	283678

General Notes:

1. Capacities at 30 psig and below are based on 3 psig overpressure.
2. For sizing purposes using the ASME actual areas, the certified coefficient of discharge K for air, gas, and steam service is 0.858.
3. For sizing purposes using the actual areas, the coefficient of discharge K for water is 0.576.
4. The "U" orifice meets the requirements of ASME Code Section VIII. Capacities listed in the table for the "U" orifice are based on 10% overpressure.



Accessories

Cap Constructions				
Standard Material & Material for Corrosive/Low Temperature Service - Stainless Steel				
Cap Description	Part Name	Std. Materials S1, N1 -20°F to 800°F	S3 -75°F to 800°F	S4 -450 °F to 450°F
Packed Lever	Cap	Carbon Steel	316 St.	316 St.
	Test Lever	Carbon Steel		
	Cam	316 St. St.		
	Cam Shaft	316 St. St.		
	Gland	316 St. St.		
	Stem Jam Nut	316 St. St.		
	Stem Test Nut	316 St. St.		
	Packing Ring	Graphite		
	Plain Washer	Steel		
	Lever Hex. Jam Nut	Steel		
	Cap Stud	Alloy Steel	Stainless Steel	Stainless Steel
	Cap Hex. Nut	Alloy Steel	Stainless Steel	Stainless Steel
Open Lever (Single or Double Acting)	Cap	Iron		
	Test Lever	Iron		
	Test Lever Fork	Iron		
	Stem Jam Nut	316 St. St.		
	Stem Test Nut	316 St. St.		
	Cap Screw	Steel, Plated		
	Fork Rd. Hd. Rivet	Steel		
	Lever Rd. Hd. Rivet	Steel		
	Cotter Pin	Steel, Plated		

Cap Constructions							
Standard Material for Corrosive Service - Monel & Hastelloy C							
Cap Description	Part Name	Monel			Hastelloy C		
		M2 -20°F to 800°F		M3 & M4 -20°F to 800°F	H2 -20°F to 800°F		H3 & H4 -20°F to 800°F
		Conventional	BalanSeal	Conventional & BalanSeal	Conventional	BalanSeal	Conventional & BalanSeal
Packed Lever	Cap			Monel			Hastelloy C
	Test Lever						
	Cam	Monel		Monel	Monel		Hastelloy C
	Cam Shaft	Monel		Monel	Monel		Hastelloy C
	Gland	Monel		Monel	Monel		Hastelloy C
	Stem Jam Nut	Monel		Monel	Monel		Hastelloy C
	Stem Test Nut	Monel		Monel	Monel		Graphite
	Packing Ring	Graphite		Graphite	Graphite		Not Used
	Plain Washer						
	Lever Hex. Jam Nut						
	Cap Stud			Hastelloy C			Hastelloy C
	Cap Hex. Nut			Hastelloy C			Hastelloy C
Open Lever (Single or Double Acting)	Cap						
	Test Lever						
	Test Lever Fork						
	Stem Jam Nut	Monel		Monel	Monel		Hastelloy C
	Stem Test Nut	Monel		Monel	Monel		Hastelloy C
	Cap Screw						
	Fork Rd. Hd. Rivet						
	Lever Rd. Hd. Rivet						
Cotter Pin							

Notes:

1. Any part denoted with a dash is standard. Cap assembly materials are standard in M1 & H1 trim.

2. Cap assembly materials N1 & N4 are the same as standard BalanSeal design, except the cap studs and hex nuts are B7M & 2HM (N1 trim) and B8MA & 8MA (N4 trim) respectively.

Accessories

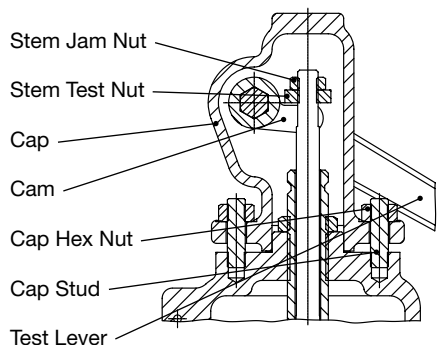
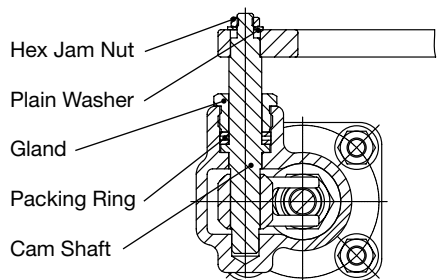

Packed Lever
2600 Series, All Sizes

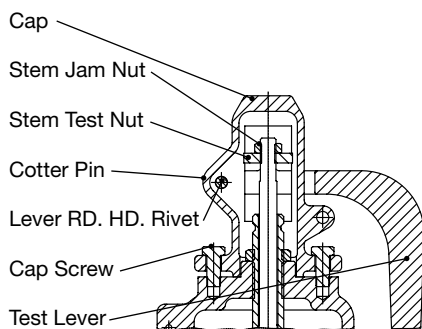

**Open Lever
(Single Acting Lever)**
2600 Series,
Types 26()A10, A11, A20, A21,
All Sizes Except 8x10

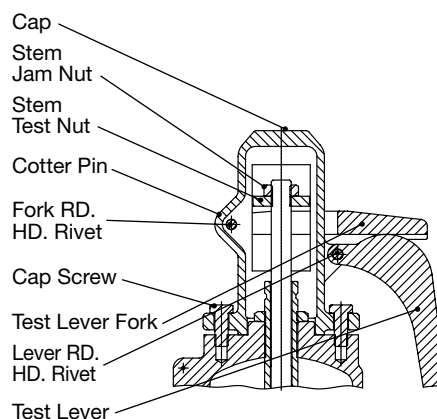

**Open Lever
(Double Acting Lever)**
2600 Series,
Sizes 1x2 Thru 6x10 Except
Types 26()A10, A11, A20, A21,
Sizes 8x10, All Types

Test Gag Installations

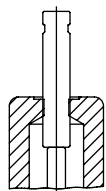

Plain Screwed Cap
2600 Series, All Sizes

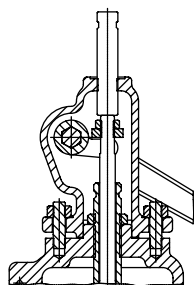

Packed Lever
2600 Series, All Sizes



Removable Plug for
Use of Test Gag

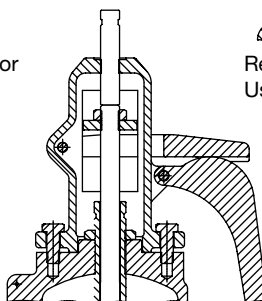

**Open Lever
(Double Acting Lever)**
2600 Series, Sizes 1x2
Thru 6x10 Except
Types 26()A10, A11
Sizes 8x10, All Types



Removable Plug for
Use of Test Gag

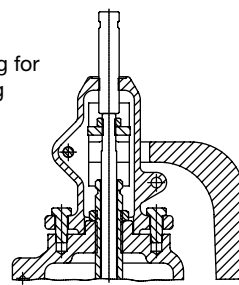

**Open Lever
(Single Acting Lever)**
2600 Series,
Types 26()A10, A11, A20, A21,
All Sizes Except 8x10

Accessories

Remotor

The Farris Remotor air operated depressuring unit is an economical way to rapidly depressurize vessels in the event of an emergency, combining pressure relief and drop out service in one installation.

- Operates by air pressure from remote point.
- Rapidly depressurizes vessels in service to predetermined limit or to zero psig.
- Extra power motor affords one regulated power supply for series of valve installations.
- Rolling diaphragm withstands greater pressures at constant effective area.
- Weatherproof and maintenance free.
- Compact design for easy installation.
- Allows normal use of test lever.

Valve Position Indicators (not shown)

Limit or proximity switch accessories are available. These devices mount on any cap construction and provide a signal locally or to remote locations to indicate the valve has operated. Consult Factory for details.

Bugproof Vent

This option is available for use on all BalanSeal bellows designs.

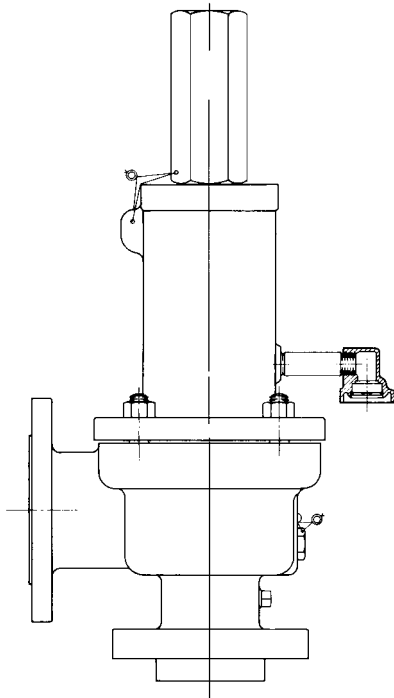
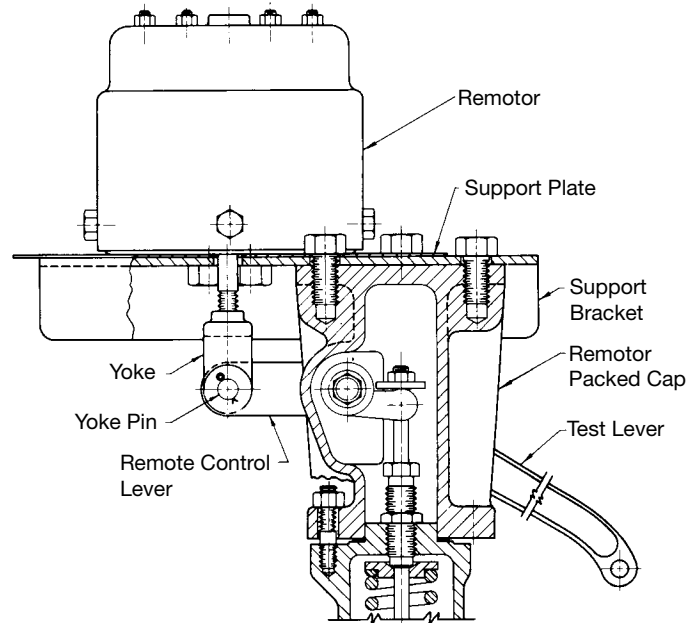

Accessories

Steam Jacketing

Viscous or heavy residual processes that tend to freeze in relief valve nozzles can create hazardous operating conditions. Jacketing or tracing of adjacent inlet piping and the pipe-away may not be enough to prevent product solidification under the valve seat or even in the valve inlet nozzle. If a pressure surge causes the valve to relieve, some of the solidified material can stick to the seat, preventing the valve from completely re-seating. This usually results in continuous process weepage around the valve seating surface.

The solution is to keep the valve warm enough to prevent build-ups of these high-melting processes.

ControHeat Bolt-On Jacket

This valve jacket is easy to install and maintain. It covers the valve flange to flange, providing uniform heat to all process wetted surfaces. The jacket consists of two aluminum castings with steel pressure chambers cast into the aluminum. The steel pressure chambers receive the heating fluid (steam, hot water or hot oil) and rapidly transfer the heat through the aluminum to the valve body. The pressure chambers are designed and tested in accordance with ASME BPV Code, Section XIII.

Standard service ratings for the jacket are 150 psig (10 barg) and 500°F (260°C). Higher ratings are available for service to 600 psig (40 barg) and 750°F (400°C). The jacket may be ordered with adjacent flange coverage.

Installation

1. Install the Farris safety relief valve in the line.
2. Verify the fit of the jacket on the valve.
3. Spread heat transfer mastic (HTM) on valve body and surfaces of jacket.
4. Bolt jacket halves onto valve. Clean excess HTM from jacket.
5. Make heating medium connections to jacket.

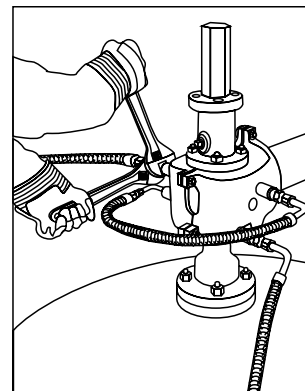
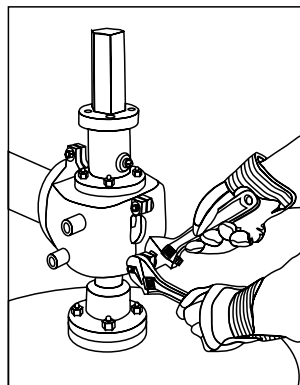
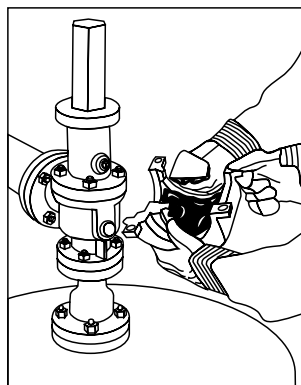
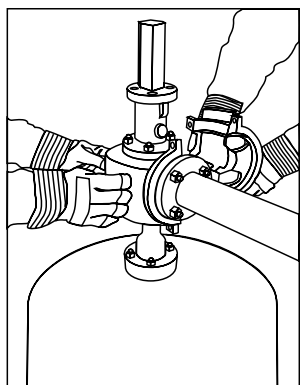
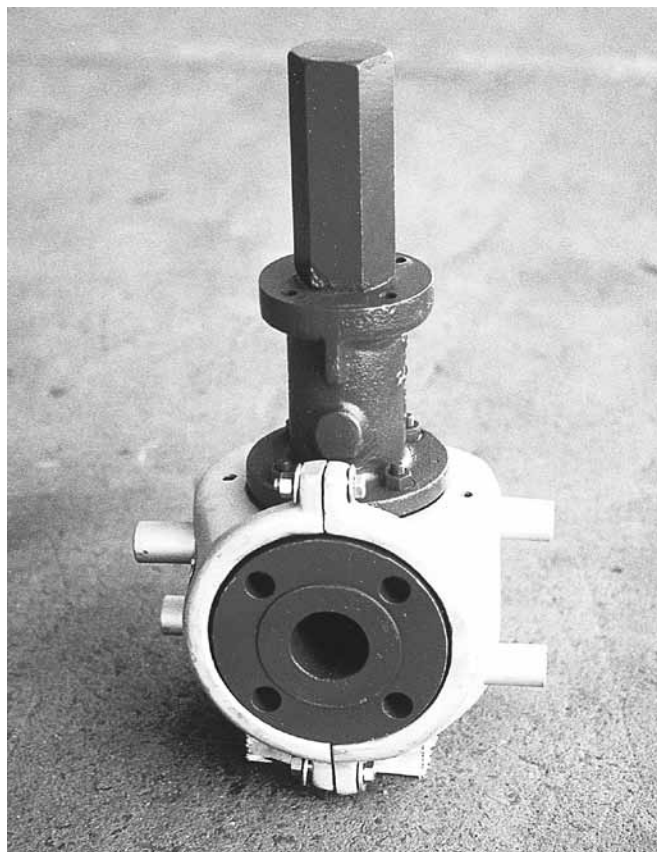

Dimensions & Weights

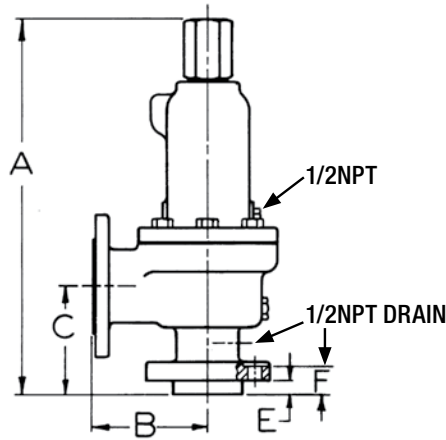

Inlet x Outlet	Type	U.S. Standard Dimensions (inches)						Approx. Weight Lbs.	Metric Dimensions (millimeters)						Approx. Weight kg
		A		B	C	E	F		A		B	C	E	F	
		Vapor	Liquid						Vapor	Liquid					
1 x 2	26DA10	19	19	4 1/2	4 1/8	1/2	1 3/16	42	483	483	115	105	13	31	20
1 x 2	26DA11	19	19	4 1/2	4 1/8	1/2	1 3/16	42	483	483	115	105	13	31	20
1 x 2	26DA12	19	19	4 1/2	4 1/8	1/2	1 3/16	42	483	483	115	105	13	31	20
1 x 2	26DA13	19	19	4 1/2	4 1/8	1/2	1 3/16	42	483	483	115	105	13	31	20
1 1/2 x 2	26DA14	23 1/2	23 1/2	5 1/2	4 1/8	11/16	1 15/16	50	597	597	140	105	18	50	23
1 1/2 x 2	26DA15	23 1/2	23 1/2	5 1/2	4 1/8	11/16	1 15/16	50	597	597	140	105	18	50	23
1 1/2 x 2 1/2	26DA16	23 1/2	23 1/2	6 1/2	5 1/2	11/16	2 7/16	80	597	597	166	140	18	62	37
1 1/2 x 3	26DA16A	23 1/2	23 1/2	7	5 1/2	11/16	2 5/8	80	597	597	178	140	18	67	37
1 x 2	26DA20	19	19	4 1/2	4 1/8	1/2	1 3/16	42	483	483	115	105	13	31	20
1 x 2	26DA21	19	19	4 1/2	4 1/8	1/2	1 3/16	42	483	483	115	105	13	31	20
1 x 2	26DA22	19	19	4 1/2	4 1/8	1/2	1 3/16	42	483	483	115	105	13	31	20
1 x 2	26DA23	19	19	4 1/2	4 1/8	1/2	1 3/16	42	483	483	115	105	13	31	20
1 1/2 x 2	26DA24	23 1/2	23 1/2	5 1/2	4 1/8	11/16	1 15/16	50	597	597	140	105	18	50	23
1 1/2 x 2	26DA25	23 1/2	23 1/2	5 1/2	4 1/8	11/16	1 15/16	50	597	597	140	105	18	50	23
1 1/2 x 2 1/2	26DA26	23 1/2	23 1/2	6 1/2	5 1/2	11/16	2 7/16	80	597	597	166	140	18	62	37
1 1/2 x 3	26DA26A	23 1/2	23 1/2	7	5 1/2	11/16	2 5/8	80	597	597	178	140	18	67	37
1 x 2	26DA32	19	19	4 1/2	4 1/8	1/2	1 3/16	42	483	483	115	105	13	31	20
1 x 2	26DA33	19	19	4 1/2	4 1/8	1/2	1 3/16	42	483	483	115	105	13	31	20
1 1/2 x 2	26DA34	23 1/2	23 1/2	5 1/2	4 1/8	11/16	1 15/16	50	597	597	140	105	18	50	23
1 1/2 x 2	26DA35	23 1/2	23 1/2	5 1/2	4 1/8	11/16	1 15/16	50	597	597	140	105	18	50	23
1 1/2 x 2 1/2	26DA36	23 1/2	23 1/2	6 1/2	5 1/2	11/16	2 7/16	80	597	597	166	140	18	62	37
1 1/2 x 3	26DA36A	23 1/2	23 1/2	7	5 1/2	11/16	2 5/8	80	597	597	178	140	18	67	37
1 x 2	26EA10	19	19	4 1/2	4 1/8	1/2	1 3/16	42	483	483	115	105	13	31	20
1 x 2	26EA11	19	19	4 1/2	4 1/8	1/2	1 3/16	42	483	483	115	105	13	31	20
1 x 2	26EA12	19	19	4 1/2	4 1/8	1/2	1 3/16	42	483	483	115	105	13	31	20
1 x 2	26EA13	19	19	4 1/2	4 1/8	1/2	1 3/16	42	483	483	115	105	13	31	20
1 1/2 x 2	26EA14	23 1/2	23 1/2	5 1/2	4 1/8	11/16	1 15/16	50	597	597	140	105	18	50	23
1 1/2 x 2	26EA15	23 1/2	23 1/2	5 1/2	4 1/8	11/16	1 15/16	50	597	597	140	105	18	50	23
1 1/2 x 2 1/2	26EA16	23 1/2	23 1/2	6 1/2	5 1/2	11/16	2 7/16	80	597	597	166	140	18	62	37
1 1/2 x 3	26EA16A	23 1/2	23 1/2	7	5 1/2	11/16	2 5/8	80	597	597	178	140	18	67	37
1 x 2	26EA20	19	19	4 1/2	4 1/8	1/2	1 3/16	42	483	483	115	105	13	31	20
1 x 2	26EA21	19	19	4 1/2	4 1/8	1/2	1 3/16	42	483	483	115	105	13	31	20
1 x 2	26EA22	19	19	4 1/2	4 1/8	1/2	1 3/16	42	483	483	115	105	13	31	20
1 x 2	26EA23	19	19	4 1/2	4 1/8	1/2	1 3/16	42	483	483	115	105	13	31	20
1 1/2 x 2	26EA24	23 1/2	23 1/2	5 1/2	4 1/8	11/16	1 15/16	50	597	597	140	105	18	50	23
1 1/2 x 2	26EA25	23 1/2	23 1/2	5 1/2	4 1/8	11/16	1 15/16	50	597	597	140	105	18	50	23
1 1/2 x 2 1/2	26EA26	23 1/2	23 1/2	6 1/2	5 1/2	11/16	2 7/16	80	597	597	166	140	18	62	37
1 1/2 x 3	26EA26A	23 1/2	23 1/2	7	5 1/2	11/16	2 5/8	80	597	597	178	140	18	67	37
1 x 2	26EA32	19	19	4 1/2	4 1/8	1/2	1 3/16	42	483	483	115	105	13	31	20
1 x 2	26EA33	19	19	4 1/2	4 1/8	1/2	1 3/16	42	483	483	115	105	13	31	20
1 1/2 x 2	26EA34	23 1/2	23 1/2	5 1/2	4 1/8	11/16	1 15/16	50	597	597	140	105	18	50	23
1 1/2 x 2	26EA35	23 1/2	23 1/2	5 1/2	4 1/8	11/16	1 15/16	50	597	597	140	105	18	50	23
1 1/2 x 2 1/2	26EA36	23 1/2	23 1/2	6 1/2	5 1/2	11/16	2 7/16	80	597	597	166	140	18	62	37
1 1/2 x 3	26EA36A	23 1/2	23 1/2	7	5 1/2	11/16	2 5/8	80	597	597	178	140	18	67	37

Dimensions & Weights

Size	Type	U.S. Standard Dimensions (inches)						Approx. Weight Lbs.	Metric Dimensions (millimeters)						Approx. Weight kg
		A		B	C	E	F		A		B	C	E	F	
		Vapor	Liquid						Vapor	Liquid					
1 1/2 x 2	26FA10	19 1/2	19 1/2	4 3/4	4 7/8	11/16	1 1/4	44	496	496	121	124	18	32	20
1 1/2 x 2	26FA11	19 1/2	19 1/2	4 3/4	4 7/8	11/16	1 9/16	44	496	496	121	124	18	40	20
1 1/2 x 2	26FA12	23	23	6	4 7/8	11/16	1 9/16	50	585	585	153	124	18	40	23
1 1/2 x 2	26FA13	23	23	6	4 7/8	11/16	1 9/16	50	585	585	153	124	18	40	23
1 1/2 x 2 1/2	26FA14	23 1/2	23 1/2	6	4 7/8	11/16	1 15/16	70	597	597	153	124	18	50	32
1 1/2 x 3	26FA14A	23 1/2	23 1/2	6 1/2	4 7/8	11/16	1 15/16	70	597	597	166	124	18	50	32
1 1/2 x 2 1/2	26FA15	23 1/2	23 1/2	6	4 7/8	11/16	1 15/16	70	597	597	153	124	18	50	32
1 1/2 x 3	26FA15A	23 1/2	23 1/2	6 1/2	4 7/8	11/16	1 15/16	70	597	597	166	124	18	50	32
1 1/2 x 2 1/2	26FA16	23 1/2	23 1/2	6 1/2	5 1/2	11/16	2 7/16	80	597	597	166	140	18	62	37
1 1/2 x 3	26FA16A	23 1/2	23 1/2	7	5 1/2	11/16	2 7/16	80	597	597	178	140	18	62	37
1 1/2 x 2	26FA20	19 1/2	19 1/2	4 3/4	4 7/8	11/16	1 1/4	44	496	496	121	124	18	32	20
1 1/2 x 2	26FA21	19 1/2	19 1/2	4 3/4	4 7/8	11/16	1 9/16	44	496	496	121	124	18	40	20
1 1/2 x 2	26FA22	23	23	6	4 7/8	11/16	1 9/16	50	585	585	153	124	18	40	23
1 1/2 x 2	26FA23	23	23	6	4 7/8	11/16	1 9/16	50	585	585	153	124	18	40	23
1 1/2 x 2 1/2	26FA24	23 1/2	23 1/2	6	4 7/8	11/16	1 15/16	70	597	597	153	124	18	50	32
1 1/2 x 3	26FA24A	23 1/2	23 1/2	6 1/2	4 7/8	11/16	1 15/16	70	597	597	166	124	18	50	32
1 1/2 x 2 1/2	26FA25	23 1/2	23 1/2	6	4 7/8	11/16	1 15/16	70	597	597	153	124	18	50	32
1 1/2 x 3	26FA25A	23 1/2	23 1/2	6 1/2	4 7/8	11/16	1 15/16	70	597	597	166	124	18	50	32
1 1/2 x 2 1/2	26FA26	23 1/2	23 1/2	6 1/2	5 1/2	11/16	2 7/16	80	597	597	166	140	18	62	37
1 1/2 x 3	26FA26A	23 1/2	23 1/2	7	5 1/2	11/16	2 7/16	80	597	597	178	140	18	62	37
1 1/2 x 2	26FA32	23	23	6	4 7/8	11/16	1 9/16	50	585	585	153	124	18	40	23
1 1/2 x 2	26FA33	23	23	6	4 7/8	11/16	1 9/16	50	585	585	153	124	18	40	23
1 1/2 x 2 1/2	26FA34	23 1/2	23 1/2	6	4 7/8	11/16	1 15/16	70	597	597	153	124	18	50	32
1 1/2 x 3	26FA34A	23 1/2	23 1/2	6 1/2	4 7/8	11/16	1 15/16	70	597	597	166	124	18	50	32
1 1/2 x 2 1/2	26FA35	23 1/2	23 1/2	6	4 7/8	11/16	1 15/16	70	597	597	153	124	18	50	32
1 1/2 x 3	26FA35A	23 1/2	23 1/2	6 1/2	4 7/8	11/16	1 15/16	70	597	597	166	124	18	50	32
1 1/2 x 2 1/2	26FA36	23 1/2	23 1/2	6 1/2	5 1/2	11/16	2 7/16	80	597	597	166	140	18	62	37
1 1/2 x 3	26FA36A	23 1/2	23 1/2	7	5 1/2	11/16	2 7/16	80	597	597	178	140	18	62	37
1 1/2 x 2 1/2	26GA10	19 1/2	19 1/2	4 3/4	4 7/8	11/16	1 1/4	50	496	496	121	124	18	32	23
1 1/2 x 3	26GA10A	19 1/2	19 1/2	4 3/4	4 7/8	11/16	1 1/4	50	496	496	121	124	18	32	23
1 1/2 x 2 1/2	26GA11	19 1/2	19 1/2	4 3/4	4 7/8	11/16	1 9/16	50	496	496	121	124	18	40	23
1 1/2 x 3	26GA11A	19 1/2	19 1/2	4 3/4	4 7/8	11/16	1 9/16	50	496	496	121	124	18	40	23
1 1/2 x 2 1/2	26GA12	23	23	6	4 7/8	11/16	1 9/16	50	585	585	153	124	18	40	23
1 1/2 x 3	26GA12A	23	23	6	4 7/8	11/16	1 9/16	50	585	585	153	124	18	40	23
1 1/2 x 2 1/2	26GA13	23 1/2	23 1/2	6	4 7/8	11/16	1 9/16	50	597	597	153	124	18	40	23
1 1/2 x 3	26GA13A	23 1/2	23 1/2	6	4 7/8	11/16	1 9/16	50	597	597	153	124	18	40	23
1 1/2 x 2 1/2	26GA14	23 1/2	23 1/2	6	4 7/8	11/16	1 15/16	70	597	597	153	124	18	50	32
1 1/2 x 3	26GA14A	23 1/2	23 1/2	6 1/2	4 7/8	11/16	1 15/16	70	597	597	166	124	18	50	32
2 x 3	26GA15	24	24	6 3/4	6 1/8	11/16	2 3/16	85	610	610	172	156	18	56	39
2 x 3	26GA16	24	24	6 3/4	6 1/8	11/16	2 11/16	95	610	610	172	156	18	69	44
1 1/2 x 2 1/2	26GA20	19 1/2	19 1/2	4 3/4	4 7/8	11/16	1 1/4	50	496	496	121	124	18	32	23
1 1/2 x 3	26GA20A	19 1/2	19 1/2	4 3/4	4 7/8	11/16	1 1/4	50	496	496	121	124	18	32	23
1 1/2 x 2 1/2	26GA21	19 1/2	19 1/2	4 3/4	4 7/8	11/16	1 9/16	50	496	496	121	124	18	40	23
1 1/2 x 3	26GA21A	19 1/2	19 1/2	4 3/4	4 7/8	11/16	1 9/16	50	496	496	121	124	18	40	23
1 1/2 x 2 1/2	26GA22	23	23	6	4 7/8	11/16	1 9/16	50	585	585	153	124	18	40	23
1 1/2 x 3	26GA22A	23	23	6	4 7/8	11/16	1 9/16	50	585	585	153	124	18	40	23
1 1/2 x 2 1/2	26GA23	23 1/2	23 1/2	6	4 7/8	11/16	1 9/16	50	597	597	153	124	18	40	23
1 1/2 x 3	26GA23A	23 1/2	23 1/2	6	4 7/8	11/16	1 9/16	50	597	597	153	124	18	40	23
1 1/2 x 2 1/2	26GA24	23 1/2	23 1/2	6	4 7/8	11/16	1 15/16	70	597	597	153	124	18	50	32
1 1/2 x 3	26GA24A	23 1/2	23 1/2	6 1/2	4 7/8	11/16	1 15/16	70	597	597	166	124	18	50	32
2 x 3	26GA25	24	24	6 3/4	6 1/8	11/16	2 3/16	85	610	610	172	156	18	56	39
2 x 3	26GA26	24	24	6 3/4	6 1/8	11/16	2 11/16	95	610	610	172	156	18	69	44
1 1/2 x 2 1/2	26GA32	23	23	6	4 7/8	11/16	1 9/16	50	585	585	153	124	18	40	23
1 1/2 x 3	26GA32A	23	23	6	4 7/8	11/16	1 9/16	50	585	585	153	124	18	40	23
1 1/2 x 2 1/2	26GA33	23 1/2	23 1/2	6	4 7/8	11/16	1 9/16	50	597	597	153	124	18	40	23
1 1/2 x 3	26GA33A	23 1/2	23 1/2	6	4 7/8	11/16	1 9/16	50	597	597	153	124	18	40	23
1 1/2 x 2 1/2	26GA34	23 1/2	23 1/2	6	4 7/8	11/16	1 15/16	70	597	597	153	124	18	50	32
1 1/2 x 3	26GA34A	23 1/2	23 1/2	6 1/2	4 7/8	11/16	1 15/16	70	597	597	166	124	18	50	32
2 x 3	26GA35	24	24	6 3/4	6 1/8	11/16	2 3/16	85	610	610	172	156	18	56	39
2 x 3	26GA36	24	24	6 3/4	6 1/8	11/16	2 11/16	95	610	610	172	156	18	69	44
1 1/2 x 3	26HA10	20	20	4 7/8	5 1/8	11/16	1 1/4	54	508	508	124	131	18	32	25
1 1/2 x 3	26HA11	20	20	4 7/8	5 1/8	11/16	1 1/2	54	508	508	124	131	18	39	25
2 x 3	26HA12	23	23	4 7/8	5 1/8	11/16	1 11/16	70	585	585	124	131	18	43	32
2 x 3	26HA13	24	24	6 3/8	6 1/16	11/16	1 11/16	70	610	610	162	154	18	43	32
2 x 3	26HA14	24	24	6 3/8	6 1/16	11/16	2 3/16	85	610	610	162	154	18	56	39
2 x 3	26HA15	24	24	6 3/8	6 1/16	11/16	2 3/16	85	610	610	162	154	18	56	39



Dimensions & Weights

Size	Type	U.S. Standard Dimensions (inches)						Approx. Weight Lbs.	Metric Dimensions (millimeters)						Approx. Weight kg
		A		B	C	E	F		A		B	C	E	F	
		Vapor	Liquid						Vapor	Liquid					
1 1/2 x 3	26HA20	20	20	4 7/8	5 1/8	11/16	1 1/4	54	508	508	124	131	18	32	25
1 1/2 x 3	26HA21	20	20	4 7/8	5 1/8	11/16	1 1/2	54	508	508	124	131	18	39	25
2 x 3	26HA22	23	23	4 7/8	5 1/8	11/16	1 11/16	70	585	585	124	131	18	43	32
2 x 3	26HA23	24	24	6 3/8	6 1/16	11/16	1 11/16	70	610	610	162	154	18	43	32
2 x 3	26HA24	24	24	6 3/8	6 1/16	11/16	2 3/16	85	610	610	162	154	18	56	39
2 x 3	26HA25	24	24	6 3/8	6 1/16	11/16	2 3/16	85	610	610	162	154	18	56	39
2 x 3	26HA32	23	23	4 7/8	5 1/8	11/16	1 11/16	70	585	585	124	131	18	43	32
2 x 3	26HA33	23	23	6 3/8	6 1/16	11/16	1 11/16	70	585	585	162	154	18	43	32
2 x 3	26HA34	24	24	6 3/8	6 1/16	11/16	2 3/16	85	610	610	162	154	18	56	39
2 x 3	26HA35	24	24	6 3/8	6 1/16	11/16	2 3/16	85	610	610	162	154	18	56	39
2 x 3	26JA10	23	23	4 7/8	5 3/8	11/16	1 5/16	58	585	585	124	137	18	34	27
2 x 3	26JA11	23	23	4 7/8	5 3/8	11/16	1 11/16	58	585	585	124	137	18	43	27
2 1/2 x 4	26JA12	25	27	5 5/8	5 3/8	11/16	1 13/16	150	635	686	143	137	18	47	69
3 x 4	26JA12A	26	28 1/2	7 1/8	7 1/4	11/16	2 1/8	150	661	724	181	185	18	54	69
2 1/2 x 4	26JA13	27 1/2	34 1/2	6 3/4	6 1/8	11/16	1 13/16	150	699	877	172	156	18	47	69
3 x 4	26JA13A	28 1/2	35 1/2	7 1/8	7 1/4	11/16	2 1/8	150	724	902	181	185	18	54	69
3 x 4	26JA14	36	36	7 1/8	7 1/4	11/16	2 3/16	175	915	915	181	185	18	56	80
3 x 4	26JA15	36	36	7 1/8	7 1/4	11/16	2 9/16	175	915	915	181	185	18	66	80
2 x 3	26JA20	23	23	4 7/8	5 3/8	11/16	1 5/16	58	585	585	124	137	18	34	27
2 x 3	26JA21	23	23	4 7/8	5 3/8	11/16	1 11/16	58	585	585	124	137	18	43	27
2 1/2 x 4	26JA22	25	27	5 5/8	5 3/8	11/16	1 13/16	150	635	686	143	137	18	47	69
3 x 4	26JA22A	26	28 1/2	7 1/8	7 1/4	11/16	2 1/8	150	661	724	181	185	18	54	69
2 1/2 x 4	26JA23	27 1/2	34 1/2	6 3/4	6 1/8	11/16	1 13/16	150	699	877	172	156	18	47	69
3 x 4	26JA23A	28 1/2	35 1/2	7 1/8	7 1/4	11/16	2 1/8	150	724	902	181	185	18	54	69
3 x 4	26JA24	36	36	7 1/8	7 1/4	11/16	2 3/16	175	915	915	181	185	18	56	80
3 x 4	26JA25	36	36	7 1/8	7 1/4	11/16	2 3/16	175	915	915	181	185	18	56	80
2 1/2 x 4	26JA32	25	27	5 5/8	5 3/8	11/16	1 13/16	150	635	686	143	137	18	47	69
3 x 4	26JA32A	26	28 1/2	7 1/8	7 1/4	11/16	2 1/8	150	661	724	181	185	18	54	69
2 1/2 x 4	26JA33	27 1/2	34 1/2	5 5/8	5 3/8	11/16	1 13/16	150	699	877	143	137	18	47	69
3 x 4	26JA33A	28 1/2	35 1/2	7 1/8	7 1/4	11/16	2 1/8	150	724	902	181	185	18	54	69
2 1/2 x 4	26JA34	25	25	6 3/4	6 1/8	11/16	2 5/16	175	635	635	172	156	18	59	80
3 x 4	26JA34A	26	26	7 1/8	7 1/4	11/16	2 3/8	175	661	661	181	185	18	61	80
3 x 4	26JA35	36	36	7 1/4	7 1/8	11/16	2 9/16	175	915	915	185	181	18	66	80
3 x 4	26KA10	26 1/2	28 1/2	6 3/8	6 1/8	11/16	1 1/2	145	674	724	162	156	18	39	66
3 x 4	26KA11	26 1/2	28 1/2	6 3/8	6 1/8	11/16	1 15/16	145	674	724	162	156	18	50	66
3 x 4	26KA12	28 1/2	32	6 3/8	6 1/8	11/16	1 15/16	160	724	813	162	156	18	50	73
3 x 4	26KA13	35 1/2	35 1/2	7 1/8	7 1/4	11/16	1 15/16	160	902	902	181	185	18	50	73
3 x 6	26KA14	37 1/2	37 1/2	8 1/2	7 13/16	11/16	2 3/16	230	953	953	216	199	18	56	105
3 x 6	26KA15	37 1/2	37 1/2	8 1/2	7 3/4	11/16	2 9/16	230	953	953	216	197	18	66	105
3 x 4	26KA20	26 1/2	28 1/2	6 3/8	6 1/8	11/16	1 1/2	145	674	724	162	156	18	39	66
3 x 4	26KA21	26 1/2	28 1/2	6 3/8	6 1/8	11/16	1 15/16	145	674	724	162	156	18	50	66
3 x 4	26KA22	28 1/2	32	6 3/8	6 1/8	11/16	1 15/16	160	724	813	162	156	18	50	73
3 x 4	26KA23	35 1/2	35 1/2	7 1/8	7 1/4	11/16	1 15/16	160	902	902	181	185	18	50	73
3 x 6	26KA24	37 1/2	37 1/2	8 1/2	7 13/16	11/16	2 3/16	230	953	953	216	199	18	56	105
3 x 6	26KA25	37 1/2	37 1/2	8 1/2	7 3/4	11/16	2 9/16	230	953	953	216	197	18	66	105
3 x 4	26KA32	28 1/2	32	6 3/8	6 1/8	11/16	1 15/16	160	724	813	162	156	18	50	73
3 x 4	26KA33	28 1/2	28 1/2	6 3/8	6 1/8	11/16	1 15/16	160	724	724	162	156	18	50	73
3 x 4	26KA34	34	34	7 1/8	7 1/4	11/16	2 3/16	230	864	864	181	185	18	56	105
3 x 6	26KA34A	35 1/2	35 1/2	8 1/2	7 13/16	11/16	2 3/8	175	902	902	216	199	18	61	80
3 x 6	26KA35	37 1/2	37 1/2	8 1/2	7 3/4	11/16	2 9/16	230	953	953	216	197	18	66	105
3 x 4	26LA10	26 1/2	28 1/2	6 1/2	6 1/8	11/16	1 1/2	145	674	724	166	156	18	39	66
3 x 4	26LA11	26 1/2	28 1/2	6 1/2	6 1/8	11/16	1 15/16	145	674	724	166	156	18	50	66
4 x 6	26LA12	38 1/2	38 1/2	7 1/8	7 1/16	11/16	1 15/16	230	978	978	181	180	18	50	105
4 x 6	26LA13	38 1/2	38 1/2	8	7 1/16	11/16	2 3/16	230	978	978	204	180	18	56	105
4 x 6	26LA14	43	43	8 3/4	7 3/4	11/16	2 7/16	250	1093	1093	223	197	18	62	114
3 x 4	26LA20	26 1/2	28 1/2	6 1/2	6 1/8	11/16	1 1/2	145	674	724	166	156	18	39	66
3 x 4	26LA21	26 1/2	28 1/2	6 1/2	6 1/8	11/16	1 15/16	145	674	724	166	156	18	50	66
4 x 6	26LA22	38 1/2	38 1/2	7 1/8	7 1/16	11/16	1 15/16	230	978	978	181	180	18	50	105
4 x 6	26LA23	38 1/2	38 1/2	8	7 1/16	11/16	2 3/16	230	978	978	204	180	18	56	105
4 x 6	26LA24	43	43	8 3/4	7 3/4	11/16	2 7/16	250	1093	1093	223	197	18	62	114
4 x 6	26LA25	43	43	8 3/4	7 3/4	11/16	2 13/16	250	1093	1093	223	197	18	72	114
4 x 6	26LA32	38 1/2	38 1/2	7 1/8	7 1/16	11/16	1 15/16	230	978	978	181	180	18	50	105
4 x 6	26LA33	38 1/2	38 1/2	8	7 1/16	11/16	2 3/16	230	978	978	204	180	18	56	105
4 x 6	26LA34	43	43	8 3/4	7 3/4	11/16	2 7/16	250	1093	1093	223	197	18	62	114
4 x 6	26LA35	43	43	8 3/4	7 3/4	11/16	2 13/16	250	1093	1093	223	197	18	72	114

Dimensions & Weights

Size Inlet x Outlet	Type	U.S. Standard Dimensions (inches)						Approx. Weight Lbs.	Metric Dimensions (millimeters)						Approx. Weight kg	
		Conventional	A		B	C	E		F	A		B	C	E		F
			Vapor	Liquid						Vapor	Liquid					
4 x 6	26MA10	31 1/2	38 1/2	7 1/4	7	11/16	1 15/16	190	801	978	185	178	18	50	87	
4 x 6	26MA11	31 1/2	38 1/2	7 1/4	7	11/16	1 15/16	190	801	978	185	178	18	50	87	
4 x 6	26MA12	38 1/2	38 1/2	7 1/4	7	11/16	1 15/16	230	978	978	185	178	18	50	105	
4 x 6	26MA13	43	43	8	7	11/16	2 3/16	250	1093	1093	204	178	18	56	114	
4 x 6	26MA20	31 1/2	38 1/2	7 1/4	7	11/16	1 15/16	190	801	978	185	178	18	50	87	
4 x 6	26MA21	31 1/2	38 1/2	7 1/4	7	11/16	1 15/16	190	801	978	185	178	18	50	87	
4 x 6	26MA22	38 1/2	38 1/2	7 1/4	7	11/16	1 15/16	230	978	978	185	178	18	50	105	
4 x 6	26MA23	43	43	8	7	11/16	2 3/16	250	1093	1093	204	178	18	56	114	
4 x 6	26MA24	43	43	8 3/4	7 3/4	11/16	2 7/16	250	1093	1093	223	197	18	62	114	
4 x 6	26MA32	37 1/2	37 1/2	7 1/4	7	11/16	1 15/16	230	953	953	185	178	18	50	105	
4 x 6	26MA33	37 1/2	37 1/2	8	7	11/16	2 3/16	250	953	953	204	178	18	56	114	
4 x 6	26MA34	43	43	8 3/4	7 3/4	11/16	2 7/16	250	1093	1093	223	197	18	62	114	
4 x 6	26NA10	31 1/2	38 1/2	8 1/4	7 3/4	11/16	1 15/16	190	801	978	210	197	18	50	87	
4 x 6	26NA11	31 1/2	38 1/2	8 1/4	7 3/4	11/16	1 15/16	190	801	978	210	197	18	50	87	
4 x 6	26NA12	38 1/2	38 1/2	8 1/4	7 3/4	11/16	1 15/16	230	978	978	210	197	18	50	105	
4 x 6	26NA13	43	43	8 3/4	7 3/4	11/16	2 3/16	250	1093	1093	223	197	18	56	114	
4 x 6	26NA14	43	43	8 3/4	7 3/4	11/16	2 7/16	250	1093	1093	223	197	18	62	114	
4 x 6	26NA20	31 1/2	38 1/2	8 1/4	7 3/4	11/16	1 15/16	190	801	978	210	197	18	50	87	
4 x 6	26NA21	31 1/2	38 1/2	8 1/4	7 3/4	11/16	1 15/16	190	801	978	210	197	18	50	87	
4 x 6	26NA22	38 1/2	38 1/2	8 1/4	7 3/4	11/16	1 15/16	230	978	978	210	197	18	50	105	
4 x 6	26NA23	43	43	8 3/4	7 3/4	11/16	2 15/16	250	1093	1093	223	197	18	75	114	
4 x 6	26NA24	43	43	8 3/4	7 3/4	11/16	2 7/16	250	1093	1093	223	197	18	62	114	
4 x 6	26NA32	38 1/2	38 1/2	8 1/4	7 3/4	11/16	1 15/16	230	978	978	210	197	18	50	105	
4 x 6	26NA33	38 1/2	43	8 3/4	7 3/4	11/16	2 3/16	250	978	1093	223	197	18	56	114	
4 x 6	26NA34	43	43	8 3/4	7 3/4	11/16	2 7/16	250	1093	1093	223	197	18	62	114	
4 x 6	26PA10	31 1/2	38 1/2	9	7 1/8	11/16	1 5/8	190	801	978	229	181	18	42	87	
4 x 6	26PA11	31 1/2	38 1/2	9	7 1/8	11/16	1 15/16	190	801	978	229	181	18	50	87	
4 x 6	26PA12	38 1/2	38 1/2	10	8 7/8	11/16	2 3/16	230	978	978	254	226	18	56	105	
4 x 6	26PA13	43	43	10	8 7/8	11/16	2 3/16	250	1093	1093	254	226	18	56	114	
4 x 6	26PA14	43	43	10	8 7/8	11/16	2 7/16	250	1093	1093	254	226	18	62	114	
4 x 6	26PA20	31 1/2	38 1/2	9	7 1/8	11/16	1 5/8	190	801	978	229	181	18	42	87	
4 x 6	26PA21	31 1/2	38 1/2	9	7 1/8	11/16	1 15/16	190	801	978	229	181	18	50	87	
4 x 6	26PA22	38 1/2	38 1/2	10	8 7/8	11/16	2 3/16	230	978	978	254	226	18	56	105	
4 x 6	26PA23	43	43	10	8 7/8	11/16	2 3/16	250	1093	1093	254	226	18	56	114	
4 x 6	26PA24	43	43	10	8 7/8	11/16	2 7/16	250	1093	1093	254	226	18	62	114	
4 x 6	26PA32	38 1/2	38 1/2	10	8 7/8	11/16	2 3/16	230	978	978	254	226	18	56	105	
4 x 6	26PA33	43	43	10	8 7/8	11/16	2 3/16	250	1093	1093	254	226	18	56	114	
4 x 6	26PA34	43	43	10	8 7/8	11/16	2 7/16	250	1093	1093	254	226	18	62	114	
6 x 8	26QA10	40 1/2	51	9 1/2	9 7/16	13/16	1 7/8	345	1029	1296	242	240	21	48	157	
6 x 8	26QA11	40 1/2	51	9 1/2	9 7/16	13/16	2 1/4	345	1029	1296	242	240	21	58	157	
6 x 8	26QA12	45	51	9 1/2	9 7/16	13/16	2 1/4	430	1143	1296	242	240	21	58	196	
6 x 8	26QA13	51	51	9 1/2	9 7/16	13/16	2 11/16	430	1296	1296	242	240	21	69	196	
6 x 8	26QA20	40 1/2	51	9 1/2	9 7/16	13/16	1 7/8	345	1029	1296	242	240	21	48	157	
6 x 8	26QA21	40 1/2	51	9 1/2	9 7/16	13/16	2 1/4	345	1029	1296	242	240	21	58	157	
6 x 8	26QA22	45	51	9 1/2	9 7/16	13/16	2 1/4	430	1143	1296	242	240	21	58	196	
6 x 8	26QA23	51	51	9 1/2	9 7/16	13/16	2 11/16	430	1296	1296	242	240	21	69	196	
6 x 8	26QA32	45	51	9 1/2	9 7/16	13/16	2 1/4	430	1143	1296	242	240	21	58	196	
6 x 8	26QA33	51	51	9 1/2	9 7/16	13/16	2 11/16	430	1296	1296	242	240	21	69	196	
6 x 8	H26QA13, 23, 33	51	51	9 1/2	9 7/16	13/16	2 11/16	530	1296	1296	242	240	21	69	241	
6 x 8	26RA10	40 1/2	51	9 1/2	9 7/16	13/16	1 7/8	345	1029	1296	242	240	21	48	157	
6 x 8	26RA11	40 1/2	51	9 1/2	9 7/16	13/16	2 1/4	345	1029	1296	242	240	21	58	157	
6 x 10	26RA12	45	51	10 1/2	9 7/16	13/16	2 1/4	500	1143	1296	267	240	21	58	227	
6 x 10	26RA13	51	51	10 1/2	9 7/16	13/16	2 11/16	500	1296	1296	267	240	21	69	227	
6 x 8	26RA20	40 1/2	51	9 1/2	9 7/16	13/16	1 7/8	345	1029	1296	242	240	21	48	157	
6 x 8	26RA21	40 1/2	51	9 1/2	9 7/16	13/16	2 1/4	345	1029	1296	242	240	21	58	157	
6 x 10	26RA22	45	51	10 1/2	9 7/16	13/16	2 1/4	500	1143	1296	267	240	21	58	227	
6 x 10	26RA23	51	51	10 1/2	9 7/16	13/16	2 11/16	500	1296	1296	267	240	21	69	227	
6 x 8	26RA32	45	51	9 1/2	9 7/16	13/16	2 1/4	430	1143	1296	242	240	21	58	196	
6 x 10	26RA33	51	51	10 1/2	9 7/16	13/16	2 11/16	500	1296	1296	267	240	21	69	227	
6 x 10	H26RA13, 23, 33	51	51	10 1/2	9 7/16	13/16	2 11/16	600	1296	1296	267	240	21	69	273	
8 x 10	26TA10	49	54 1/2	11	10 7/8	13/16	2 7/16	600	1245	1385	280	277	21	62	273	
8 x 10	26TA11	49	54 1/2	11	10 7/8	13/16	2 7/16	650	1245	1385	280	277	21	62	295	
8 x 10	26TA12	49	54 1/2	11	10 7/8	13/16	2 7/16	650	1245	1385	280	277	21	62	295	
8 x 10	26TA20	49	54 1/2	11	10 7/8	13/16	2 7/16	600	1245	1385	280	277	21	62	273	
8 x 10	26TA21	49	54 1/2	11	10 7/8	13/16	2 7/16	650	1245	1385	280	277	21	62	295	
8 x 10	26TA22	49	54 1/2	11	10 7/8	13/16	2 7/16	650	1245	1385	280	277	21	62	295	
8 x 10	26TA32	49	54 1/2	11	10 7/8	13/16	2 7/16	650	1245	1385	280	277	21	62	295	
8 x 10	H26TA12, 22, 32	54 1/2	54 1/2	11	10 7/8	13/16	2 7/16	750	1385	1385	280	277	21	62	341	

ANSI Flange Connection Types

Detail of Flanges on Farris Nozzle Valves

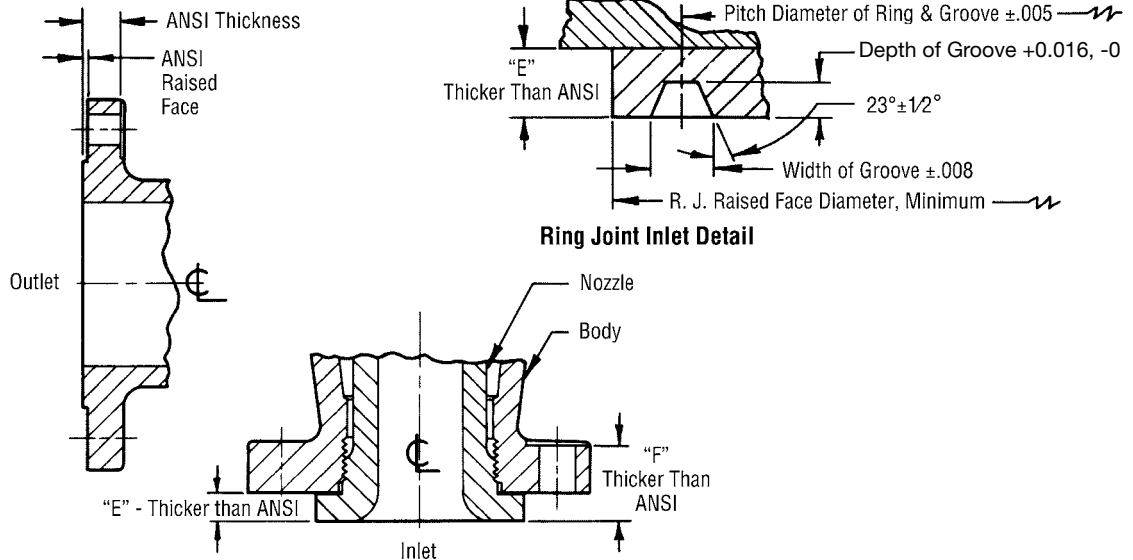

Full Nozzle Inlet Facings (Reference ANSI B16.5)

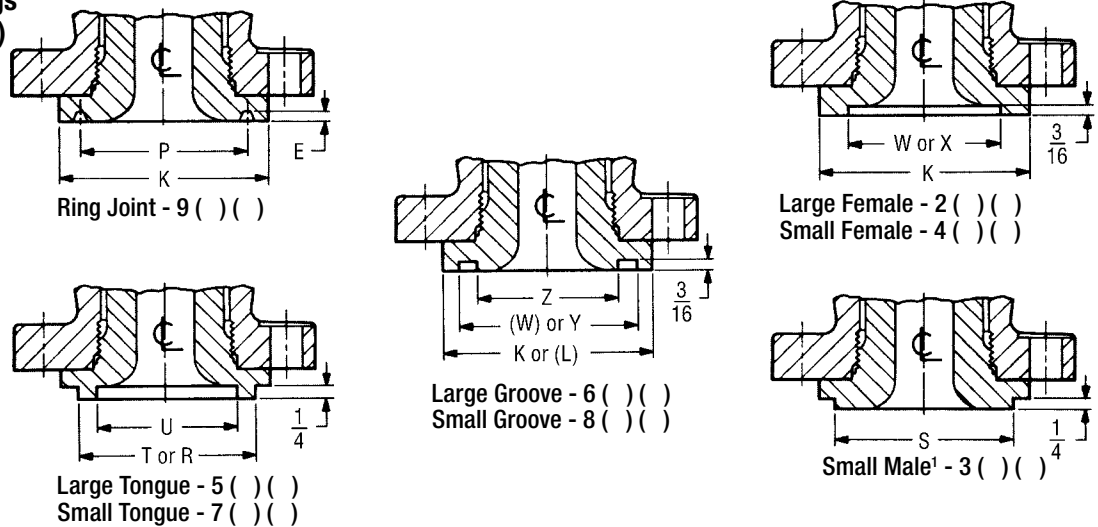

Full Nozzle Valve Flange Changes Altering Center-to-Face Dimensions

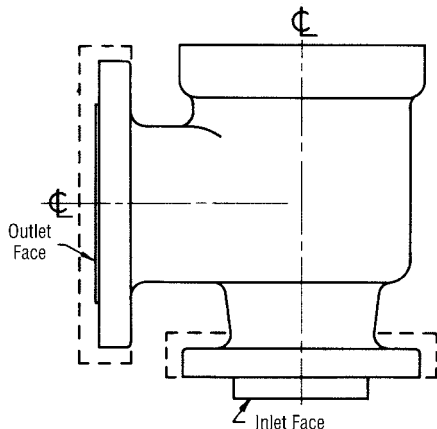

1. **Ring Joint Inlet** face and other facings have the same dimension from center line of outlet to face of inlet flange as the raised face inlet flange.
2. **Ring Joint Outlet** face and other facings increase the dimensions from center line of inlet to face of outlet flange by the difference in ANSI total flange thickness.
3. **Heavier Than Standard Outlet** flanges increase the dimension from center line of inlet to face of outlet flange by the difference in ANSI total flange thickness.
4. **Heavier Than Standard Inlet** flanges have the same dimension from center line of outlet to face of inlet flange as the standard inlet flanges.

Steel flanges conform to ANSI Standard B16.5-2003.

General Notes:

1. Standard raised face value is identical to large male dimension when nozzle without wrenching flats is supplied.
2. Optional connections shown may not be available in all sizes. Consult the factory.

ANSI Flange Dimensions

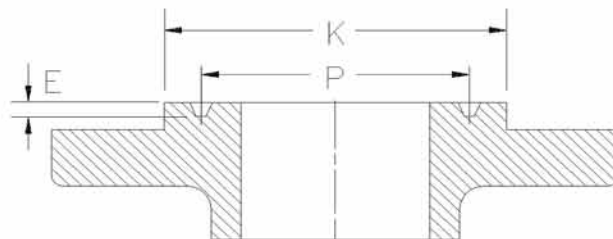
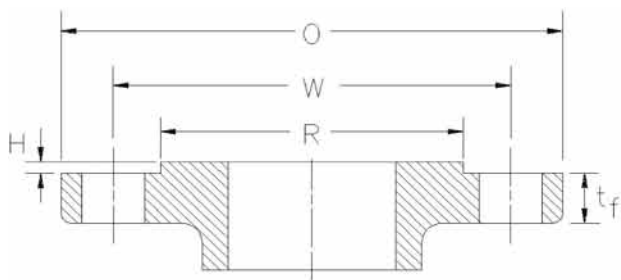

Class	Dimensions of ANSI Raised Face Flange Facings (inches)							Dimensions of Ring Joint Facings (inches)							
	Size	OD of Flange O	Min. Thickness of Flange t _f	Diam. of Bolt Circle W	Diam. of Bolt Holes	Number of Bolts	Diam. of Bolts	Diam. of Raised Face R	Diam. of Raised Face K	Pitch Diam. P	Depth of Groove E	Width of Groove	Ring Number		
Class 150 Flanges	1	4.25	0.56	3.12	0.62	4	1/2	2.00	2.50	1.875	0.250	0.344	R15		
	1½	5.00	0.69	3.88				2.88	3.25	2.562			R19		
	2	6.00	0.75	4.75				3.62	4.00	3.250			R22		
	2½	7.00	0.88	5.50				4.12	4.75	4.000			R25		
	3	7.50	0.94	6.00	0.75	8	5/8	5.00	5.25	4.500			R29		
	4	9.00		7.50				6.19	6.75	5.875			R36		
	6	11.00	1.00	9.50	0.88	8	3/4	8.50	8.62	7.625			R43		
	8	13.50	1.12	11.75				10.62	10.75	9.750			R48		
	10	16.00	1.19	14.25	1.00	12	7/8	12.75	13.00	12.000			R52		
	Class 300 Flanges	1	4.88	0.69	3.50	0.75	4	5/8	2.00	Use Class 600 dimensions in these sizes.					
1½		6.12	0.81	4.50	0.88	3/4		2.88							
2		6.50	0.88	5.00	0.75	8	5/8	3.62							
2½		7.50	1.00	5.88	3/4		4.12								
3		8.25	1.12	6.62			5.00								
4		10.00	1.25	7.88	6.19										
6		12.50	1.44	10.62	12	7/8	10.62	8.50							
8		15.00	1.62	13.00		1.00	1	12.75							
10		17.50	1.88	15.25	1.12	16	1	12.75							
Class 600 Flanges		1	4.88	0.69	3.50	0.75	4	5/8	2.00						2.75
	1½	6.12	0.88	4.50	0.88	3/4		2.88	3.56	2.688	R20				
	2	6.50	1.00	5.00	0.75	8	5/8	3.62	4.25	3.250	0.312	0.469	R23		
	2½	7.50	1.12	5.88	3/4		4.12	5.00	4.000						
	3	8.25	1.25	6.62			5.00	5.75	4.875						
	4	10.75	1.50	8.50	1.00		7/8	6.19	6.88	5.875			R37		
	6	14.00	1.88	11.50	1.12	12	1	8.50	9.50	8.312	R45				
	8	16.50	2.19	13.75	1.25		1-1/8	10.62	11.88	10.625	R49				
	10	20.00	2.50	17.00	1.38	16	1-1/4	12.75	14.00	12.750	R53				
	Class 900 Flanges	1	Use Class 1500 dimensions in these sizes.												
1½															
2															
2½															
3		9.50	1.50	7.50	1.00	8	7/8	5.00	6.12	4.875	0.312	0.469	R31		
4		11.50	1.75	9.25	1.25		1-1/8	6.19	7.12	5.875			R37		
6	15.00	2.19	12.50	12	8.50	9.50	8.312	R45							
1	5.88	1.12	4.00		1.00	4	7/8	2.00	2.81	2.000	0.250	0.344	R16		
1-1/2	7.00	1.25	4.88	1.12	1		2.88	3.62	2.688	R20					
2	8.50	1.50	6.50	1.00	8	7/8	3.62	4.88	3.750	0.312	0.469	R24			
2-1/2	9.62	1.62	7.50	1.12		1	4.12	5.38	4.250			R27			
3	10.50	1.88	8.00	1.25		1-1/8	5.00	6.62	5.375			R35			
4	12.25	2.12	9.50	1.38		1-1/4	6.19	7.62	6.375			R39			
6	15.50	3.25	12.50	1.50	12	1-3/8	8.50	9.75	8.312	0.375	0.531	R46			
Class 1500 Flanges	1	6.25	1.38	4.25	1.00	4	7/8	2.00	3.25	2.375	0.250	0.344	R18		
	1½	8.00	1.75	5.75	1.25		1-1/8	2.88	4.50	3.250			R23		
	2	9.25	2.00	6.75	1.12	8	1	3.62	5.25	4.000	0.312	0.469	R26		
	2½	10.50	2.25	7.75	1.25		1-1/8	4.12	5.88	4.375			R28		
	3	12.00	2.62	9.00	1.38		1-1/4	5.00	6.62	5.000			0.375	0.531	R32
	1	6.25	1.38	4.25	1.00		4	7/8	2.00	3.25			2.375	0.250	0.344
1½	8.00	1.75	5.75	1.25	1-1/8	2.88		4.50	3.250	R23					
Class 2500 Flanges	2	9.25	2.00	6.75	1.12	8	1	3.62	5.25	4.000	0.312	0.469	R26		
	2½	10.50	2.25	7.75	1.25		1-1/8	4.12	5.88	4.375			R28		
	3	12.00	2.62	9.00	1.38		1-1/4	5.00	6.62	5.000			0.375	0.531	R32

General Notes:

1. Feature C' applies to flange class 600 and above, class 150 and 300 use C.
2. Feature H equals 0.06 inches for class 150 and 300 flanges; 0.25 inches for class 600 and above.
3. Dimensions taken from ASME/ANSI B16.5 for flanged fittings.

DIN Flange Dimensions

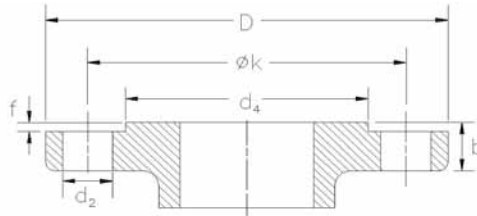

Class	Size (DN)	Dimensions of DIN Flange Facings (millimeters)										
		Flange			Raised Face		Bolts					
		OD of Flange D	Min. Thickness of Flange b	Dia. of Bolt Circle k	Dia. of Raised Face d ₄	Raised Face Height f	Number of Bolts	Thread	Dia. of Bolt Holes d ₂			
Nominal Pressure 10	25	Use nominal pressure 16 dimensions for these sizes.										
	40											
	50											
	65											
	80											
	100											
	150	340	24	295	268	3	8	M 20	22			
	200	395	26	350	320		12					
Nominal Pressure 16	25	Use nominal pressure 40 dimensions for these sizes.										
	40											
	50											
	65	185	18	145	122	3	4	M 16	18			
	80	200	20	160	138		8					
	100	220	20	180	158		12			M 20	22	
	150	285	22	240	212							
	200	340	24	295	268		M 24	26				
250	405	26	355	320								
Nominal Pressure 25	25	Use nominal pressure 40 dimensions for these sizes.										
	40											
	50											
	65											
	80											
	100											
	150	350	30	310	278	3	12	M 24	26			
	200	425	32	370	335			M 27	30			
250	450	38	385	345								
Nominal Pressure 40	25	115	18	85	68	2	4	M 12	14			
	40	150	18	110	88							
	50	165	20	125	102	3	8	M 16	18			
	65	185	22	145	122							
	80	200	24	160	138							
	100	235	24	190	162							
	150	300	28	250	218							
	200	375	34	320	285	12	M 27	30				
250	450	38	385	345	M 30				33			
Nominal Pressure 64	25	Use nominal pressure 160 dimensions for these sizes.										
	40											
	50	180	26	135	102	3	4	M 20	22			
	65	205	26	160	122		8					
	80	215	28	170	138		12			M 24	26	
	100	250	30	200	162							
150	345	36	280	218	M 30		33					
Nominal Pressure 100	25	Use nominal pressure 160 dimensions for these sizes.										
	40											
	50											
	65											
	80											
	100											
150	355	44	290	218	3	12	M 30	33				
Nominal Pressure 160	25	140	24	100	68	2	4	M 16	18			
	40	170	28	125	88							
	50	195	30	145	102	3	8	M 24	26			
	65	220	34	170	122							
	80	230	36	180	138							
	100	265	40	210	162					12	M 27	30
	150	355	50	290	218							

Valve Pressure Limits

Austenitic Stainless Steel: ASME SA-351 Grade CF8M ¹ -316 St. St										
Orifice Letter	Valve Size	ANSI Flange Class		Maximum Pressure (psig)					Back Pressure Limit ⁶	
				Temperature Range					Conventional Type	BalnSeal Type
				-450°F to -76°F	-75°F to 100°F	450°F	800°F	1000°F		
D	1D2	150	150	275	275	180	80	20	275	230
	1D2 ²	300	150	275	275	275	275	275	275	230
	1D2	300	150	720	720	495	420	350	275	230
	1D2	600	150	1440	1440	990	845	700	275	230
	1-1/2 D2	900	300	2160	2160	1485	1265	1050	600	500
	1-1/2 D2	1500	300	3600	3600	2480	2110	1750	600	500
	1-1/2 D3	2500	300	4000	6000	4130	3520	2915	720	500
E	1E2	150	150	275	275	180	80	20	275	230
	1E2 ²	300	150	275	275	275	275	275	275	230
	1E2	300	150	720	720	495	420	350	275	230
	1E2	600	150	1440	1440	975	845	700	275	230
	1-1/2 E2	900	300	2160	2160	1485	1265	1050	600	500
	1-1/2 E2	1500	300	3600	3600	2480	2110	1750	600	500
	1-1/2 E3	2500	300	4000	6000	4130	3520	2915	720	500
F	1-1/2 F2	150	150	275	275	180	80	20	275	230
	1-1/2 F2 ²	300	150	275	275	275	275	275	275	230
	1-1/2 F2	300	150	720	720	495	420	350	275	230
	1-1/2 F2	600	150	1440	1440	975	845	700	275	230
	1-1/2 F3	900	300	2160	2160	1485	1265	1050	600	500
	1-1/2 F3	1500	300	2200	3600	2480	2110	1750	600	500
	1-1/2 F3	2500	300	3400	5000	4130	3520	2915	720	500
G	1-1/2 G3	150	150	275	275	180	80	20	275	230
	1-1/2 G3 ²	300	150	275	275	275	275	275	275	230
	1-1/2 G3	300	150	720	720	495	420	350	275	230
	1-1/2 G3	600	150	1440	1440	975	845	700	275	230
	1-1/2 G3	900	300	2160	2160	1485	1265	1050	600	470
	2G3	1500	300	2450	3600	2480	2110	1750	600	470
	2G3	2500	300	2600	3600	3600	3520	2915	720	470
H	1-1/2 H3	150	150	275	275	180	80	20	275	230
	1-1/2 H3 ²	300	150	275	275	275	275	275	275	230
	2H3	300	150	720	720	495	420	350	275	230
	2H3	600	150	1440	1440	975	845	700	275	230
	2H3	900	150	1485	2160	1485	1265	1050	275	230
	2H3	1500	300	1600	2750	2480	2110	1750	600	415
J	2J3	150	150	275	275	180	80	20	275	230
	2J3 ²	300	150	275	275	275	275	275	275	230
	3J4	300	150	500	720	495	420	350	275	230
	3J4	600	150	625	1440	975	845	700	275	230
	3J4	900	150	800	2160	1485	1265	1050	275	230
	3J4	1500	300	800	2700	2480	2110	1750	600	230

General Notes:

1. Material limited to 1500°F.
2. Pressure less than rating for 300# class flange to designate maximum pressure limit when used on Farris 300# lightweight design valves.
3. High pressure version
4. Material commonly designated as 316 Stainless Steel.
5. Pressures shown represent values shown in API Standard 526 and/or ASME B16.34.
6. Back pressure limits based on temperature of 100°F.



Valve Pressure Limits

Austenitic Stainless Steel: ASME SA-351 Grade CF8M ¹ -316 St. St										
Orifice Letter	Valve Size	ANSI Flange Class		Maximum Pressure (psig)					Back Pressure Limit ⁶	
				Temperature Range						
				Inlet by Orifice	Outlet	-450°F to -76°F	-75°F to 100°F	450°F	800°F	1000°F
K	3K4	150	150	275	275	180	80	20	275	150
	3K4 ²	300	150	275	275	275	275	275	275	150
	3K4	300	150	525	720	495	420	350	275	150
	3K4	600	150	600	1440	975	845	700	275	200
	3K6	900	150	600	2160	1485	1265	1050	275	200
	3K6	1500	300	750	2220	2220	2110	1750	600	200
L	3L4	150	150	275	275	180	80	20	275	100
	3L4 ²	300	150	275	275	275	275	275	275	100
	4L6	300	150	535	720	495	420	350	275	170
	4L6	600	150	535	1000	975	845	700	275	170
	4L6	900	150	700	1500	1485	1265	1050	275	170
	4L6	1500	150	700	1500	1500	1500	1500	275	170
M	4M6	150	150	275	275	180	80	20	275	80
	4M6 ²	300	150	275	275	275	275	275	275	80
	4M6	300	150	525	720	495	420	350	275	160
	4M6	600	150	600	1000	975	845	700	275	160
	4M6	900	150	600	1100	1100	1100	1050	275	160
	N	4N6	150	150	275	275	180	80	20	275
4N6 ²		300	150	275	275	275	275	275	275	80
4N6		300	150	450	720	495	420	350	275	160
4N6		600	150	500	1000	975	845	700	275	160
4N6		900	150	500	1000	1000	1000	1000	275	160
P		4P6	150	150	175	275	180	80	20	275
	4P6 ²	300	150	175	275	275	275	275	275	80
	4P6	300	150	300	525	495	420	350	275	150
	4P6	600	150	480	1000	975	845	700	275	150
	4P6	900	150	480	1000	1000	1000	1000	275	150
	Q	6Q8	150	150	165	165	165	80	20	115
6Q8 ²		300	150	165	165	165	165	165	115	70
6Q8		300	150	250	300	300	300	300	115	115
6Q8		600	150	300	600	600	600	600	115	115
6Q8 ³		600	150	300	900	900	845	700	275	200
R		6R8	150	150	55	100	100	80	20	60
	6R8 ²	300	150	55	100	100	100	100	60	60
	6R10	300	150	150	230	230	230	230	100	100
	6R10	600	150	200	300	300	300	300	100	100
	6R10 ³	600	150	200	600	600	600	600	275	200
	T	8T10	150	150	50	65	65	65	20	30
8T10 ²		300	150	50	65	65	65	65	30	30
8T10		300	150	65	120	120	120	120	60	60
8T10 ³		300	150	65	300	300	300	300	100	100

General Notes:

1. Material limited to 1500°F.
2. Pressure less than rating for 300# class flange to designate maximum pressure limit when used on Farris 300# lightweight design valves.
3. High pressure version
4. Material commonly designated as 316 Stainless Steel.
5. Pressures shown represent values shown in API Standard 526 and/or ASME B16.34.
6. Back pressure limits based on temperature of 100°F.

Valve Pressure Limits

Nickel Alloy: ASME SA-494 Grade CW-12MW ¹ – Hastelloy C								
Orifice Letter	Valve Size	ANSI Flange Class		Maximum Pressure (psig)				
				Temperature Range			Back Pressure Limit ⁶	
				-20°F to 100°F	450°F	800°F	Conventional Type	BalanSeal Type
D	1D2	150	150	230	180	80	230	230
	1D2 ²	300	150	230	230	230	230	230
	1D2	300	150	600	477	400	230	230
	1D2	600	150	1200	952	800	230	230
	1-1/2 D2	900	300	1800	1430	1200	600	500
	1-1/2 D2	1500	300	3000	2382	2005	600	500
	1-1/2 D3	2500	300	5000	3970	3340	600	500
E	1E2	150	150	230	180	80	230	230
	1E2 ²	300	150	230	230	230	230	230
	1E2	300	150	600	477	400	230	230
	1E2	600	150	1200	952	800	230	230
	1-1/2 E2	900	300	1800	1430	1200	600	500
	1-1/2 E2	1500	300	3000	2382	2005	600	500
	1-1/2 E3	2500	300	5000	3970	3340	600	500
F	1-1/2 F2	150	150	230	180	80	230	230
	1-1/2 F2 ²	300	150	230	230	230	230	230
	1-1/2 F2	300	150	600	477	400	230	230
	1-1/2 F2	600	150	1200	952	800	230	230
	1-1/2 F3	900	300	1800	1430	1200	600	500
	1-1/2 F3	1500	300	3000	2382	2005	600	500
	1-1/2 F3	2500	300	5000	3970	3340	600	500
G	1-1/2 G3	150	150	180	180	80	230	230
	1-1/2 G3 ²	300	150	230	230	230	230	230
	1-1/2 G3	300	150	477	477	400	230	230
	1-1/2 G3	600	150	952	952	800	230	230
	1-1/2 G3	900	300	1430	1430	1200	600	470
	2G3	1500	300	2382	2382	2005	600	470
	2G3	2500	300	3970	3705	3340	600	470
H	1-1/2 H3	150	150	180	180	80	230	230
	1-1/2 H3 ²	300	150	230	230	230	230	230
	2H3	300	150	477	477	400	230	230
	2H3	600	150	952	952	800	230	230
	2H3	900	150	1430	1430	1200	230	230
	2H3	1500	300	2382	2382	2005	600	415
J	2J3	150	150	180	180	80	230	230
	2J3 ²	300	150	230	230	230	230	230
	3J4	300	150	477	477	400	230	230
	3J4	600	150	952	952	800	230	230
	3J4	900	150	1430	1430	1200	230	230
	3J4	1500	300	2382	2382	2005	600	230

General Notes:

1. Valve limited to 800°F.
2. Pressure less than rating for 300# class flange to designate maximum pressure limit when used on Farris 300# lightweight design valves.
3. High pressure version.
4. Material commonly sold under the trade name of Hastelloy C™
5. Pressure shown represent the carbon steel valve limits or Hastelloy C flange limit (per ASME B16.34), whichever is lower.
6. Back pressure limits based on temperature of 100°F.



Valve Pressure Limits

Nickel Alloy: ASME SA-494 Grade CW-12MW ¹ – Hastelloy C								
Orifice Letter	Valve Size	ANSI Flange Class		Maximum Pressure (psig)				
				Temperature Range			Back Pressure Limit ⁶	
				-20°F to 100°F	450°F	800°F	Conventional Type	BalanSeal Type
K	3K4	150	150	230	180	80	230	150
	3K4 ²	300	150	230	230	230	230	150
	3K4	300	150	600	477	400	230	150
	3K4	600	150	1200	952	800	230	200
	3K6	900	150	1800	1430	1200	230	200
	3K6	1500	300	2220	2382	2005	600	200
L	3L4	150	150	230	180	80	230	100
	3L4 ²	300	150	230	230	230	230	100
	4L6	300	150	600	477	400	230	170
	4L6	600	150	1000	952	800	230	170
	4L6	900	150	1500	1430	1200	230	170
	4L6	1500	150	1500	1500	1500	230	170
M	4M6	150	150	230	180	80	230	80
	4M6 ²	300	150	230	230	230	230	80
	4M6	300	150	600	477	400	230	160
	4M6	600	150	1100	952	800	230	160
	4M6	900	150	1100	1100	1100	230	160
N	4N6	150	150	230	180	80	230	80
	4N6 ²	300	150	230	230	230	230	80
	4N6	300	150	600	477	400	230	160
	4N6	600	150	1000	952	800	230	160
	4N6	900	150	1000	1000	1000	230	160
P	4P6	150	150	230	180	80	230	80
	4P6 ²	300	150	230	230	230	230	80
	4P6	300	150	525	477	400	230	150
	4P6	600	150	1000	952	800	230	150
	4P6	900	150	1000	1000	1000	230	150
Q	6Q8	150	150	165	165	80	140	70
	6Q8 ²	300	150	165	165	165	115	70
	6Q8	300	150	300	300	300	115	115
	6Q8	600	150	600	600	600	115	115
	6Q8 ³	600	150	900	900	825	230	200
R	6R8	150	150	100	100	80	100	60
	6R8 ²	300	150	100	100	100	60	60
	6R10	300	150	230	230	230	100	100
	6R10	600	150	300	300	300	100	100
	6R10 ³	600	150	600	600	600	230	200
T	8T10	150	150	65	65	65	65	30
	8T10 ²	300	150	65	65	65	30	30
	8T10	300	150	120	120	120	60	60
	8T10 ³	300	150	300	300	300	100	100

General Notes:

1. Valve limited to 800°F.
2. Pressure less than rating for 300# class flange to designate maximum pressure limit when used on Farris 300# lightweight design valves.
3. High pressure version.
4. Material commonly sold under the trade name of Hastelloy C™
5. Pressures shown represent the carbon steel valve limits or Hastelloy C flange limit (per ASME B16.34), whichever is lower.
6. Back pressure limits based on temperature of 100°F.

Valve Pressure Limits

Nickel / Copper Alloy: ASME SA-494 Grade M-35-1 ¹ – Monel									
Orifice Letter	Valve Size	ANSI Flange Class		Maximum Pressure (psig)					
				Temperature Range				Back Pressure Limit ⁵	
				Inlet by Orifice by Outlet	Inlet	Outlet	-20°F to 100°F	450°F	800°F
D	1D2	150	150	230	175	80	50	230	230
	1D2 ²	300	150	230	230	230	230	230	230
	1D2	300	150	600	475	460	275	230	230
	1D2	600	150	1200	945	915	550	230	230
	1-1/2 D2	900	300	1800	1420	1375	825	600	500
E	1E2	150	150	230	175	80	50	230	230
	1E2 ²	300	150	230	230	230	230	230	230
	1E2	300	150	600	475	460	275	230	230
	1E2	600	150	1200	945	915	550	230	230
	1-1/2 E2	900	300	1800	1420	1375	825	600	500
F	1-1/2 F2	150	150	230	175	80	50	230	230
	1-1/2 F2 ²	300	150	230	230	230	230	230	230
	1-1/2 F2	300	150	600	475	460	275	230	230
	1-1/2 F2	600	150	1200	945	915	550	230	230
	1-1/2 F3	900	300	1800	1420	1375	825	600	500
G	1-1/2 G3	150	150	230	175	80	50	230	230
	1-1/2 G3 ²	300	150	230	230	230	230	230	230
	1-1/2 G3	300	150	600	475	460	275	230	230
	1-1/2 G3	600	150	1200	945	915	550	230	230
	1-1/2 G3	900	300	1800	1420	1375	825	600	470
H	1-1/2 H3	150	150	230	175	80	50	230	230
	1-1/2 H3 ²	300	150	230	230	230	230	230	230
	2H3	300	150	600	475	460	275	230	230
	2H3	600	150	1200	945	915	550	230	230
	2H3	900	150	1800	1420	1375	825	230	230
J	2J3	150	150	230	175	80	50	230	230
	2J3 ²	300	150	230	230	230	230	230	230
	3J4	300	150	600	475	460	275	230	230
	3J4	600	150	1200	945	915	550	230	230
	3J4	900	150	1800	1420	1375	825	230	230
K	3K4	150	150	230	175	80	50	230	150
	3K4 ²	300	150	230	230	230	230	230	150
	3K4	300	150	600	475	460	275	230	150
	3K4	600	150	1200	945	915	550	230	200
	3K6	900	150	1800	1420	1375	825	230	200
L	3L4	150	150	230	175	80	50	230	100
	3L4 ²	300	150	230	230	230	230	230	100
	4L6	300	150	600	475	460	275	230	170
	4L6	600	150	1200	945	915	550	230	170
	4L6	900	150	1800	1420	1375	825	230	170
M	4M6	150	150	230	175	80	50	230	80
	4M6 ²	300	150	230	230	230	230	230	80
	4M6	300	150	600	475	460	275	230	160
	4M6	600	150	1100	945	915	550	230	160
	4M6	900	150	1100	1100	1100	825	230	160
N	4N6	150	150	230	175	80	50	230	80
	4N6 ²	300	150	230	230	230	230	230	80
	4N6	300	150	600	475	460	275	230	160
	4N6	600	150	1000	945	915	550	230	160
	4N6	900	150	1100	1100	1100	825	230	160
P	4P6	150	150	230	175	80	50	230	80
	4P6 ²	300	150	230	230	230	230	230	80
	4P6	300	150	600	475	460	275	230	160
	4P6	600	150	1000	945	915	550	230	160
	4P6	900	150	1000	1000	1000	825	230	150
Q	6Q8	150	150	140	165	80	50	115	70
	6Q8 ²	300	150	140	165	165	165	115	70
	6Q8	300	150	300	300	300	275	115	115
	6Q8	600	150	600	600	600	550	115	115
R	6R8	150	150	100	100	80	50	60	60
	6R8 ²	300	150	100	100	100	100	60	60
	6R10	300	150	230	230	230	230	100	100
	6R10	600	150	300	300	300	300	100	100
T	8T10	150	150	65	65	65	65	30	30
	8T10 ²	300	150	65	65	65	65	30	30
	8T10	300	150	120	120	120	120	60	60

General Notes:

1. Valve material limited to 900°F.
2. Pressure less than rating for 300# class flange to designate maximum pressure limit when used on Farris 300# lightweight design valves.
3. Material commonly sold under the trade name of Monel™.
4. Pressure and temperature limits per API Standard 526.
5. Back pressure limits based on temperature of 100°F.



Sizing

General Equations

Before beginning any calculations, it is necessary to establish the general category of the pressure relief valve to be used. This section covers conventional spring-loaded types and BalanSeal spring-loaded types. Pilot-operated valves are covered in a separate catalog.

Given the rate of fluid flow to be relieved, the usual procedure is to first calculate the minimum area required in the valve orifice for the conditions contained in one of the following equations. In the case of steam, air or water, the selection of an orifice may be made directly from the capacity tables.

The second step is to select the specific type of valve that meets the pressure and temperature requirements.

General equations are given first, to identify the basic terms that correlate with ASME Pressure Vessel Code, Section VIII.

Since these equations are conservative, it is recommended that computations of relieving loads avoid cascading of safety factors or multiple contingencies beyond the reasonable flow needed to protect the pressure vessel.

Conventional Valves – Constant Back Pressure Only

The conventional valve may be used when the variation in back pressure does not exceed 10% of the set pressure, provided the corresponding variation in set pressure is acceptable.

Orifice Area Calculations	Constant Back Pressure
VAPORS or GASES – Lbs./hr.: $A = \frac{W \sqrt{T} \sqrt{Z}}{C K_d P \sqrt{M} K_b}$	$K_b = 1$ when back pressure is below 55% of abs. relieving pressure.
VAPORS or GASES – S.C.F.M.: $A = \frac{V \sqrt{G} \sqrt{T} \sqrt{Z}}{1.175 C K_d P K_b}$	$K_b = 1$ when back pressure is below 55% of abs. relieving pressure.
STEAM – Lbs./hr.: $A = \frac{W_s}{51.5 K_d P K_b K_{sh} K_n}$	$K_b = 1$ when back pressure is below 55% of abs. relieving pressure. $K_{sh} = 1$ for Sat. Steam
AIR – S.C.F.M.: $A = \frac{V_a \sqrt{T}}{418 K_d P K_b}$	$K_b = 1$ when back pressure is below 55% of abs. relieving pressure.
LIQUIDS – 2600L Series, G.P.M, ASME Code: $A = \frac{V_l \sqrt{G}}{38.0 K_d \sqrt{\Delta P} K_u}$	$K_b = 1$ at 25% overpressure $K_u = 1$ at normal viscosities
LIQUIDS – 2600 Series, G.P.M, Non-ASME Code: $A = \frac{V_l \sqrt{G}}{38.0 K_d \sqrt{1.25 (P_1 - P_2)} K_p K_u}$	

Nomenclature

- A = Required orifice area in square inches. This value may be compared with the API effective areas included in this catalog and defined in ANSI/API Standard 526 or the ASME actual area.
- W = Required vapor capacity in pounds per hour.
- W_s = Required steam capacity in pounds per hour.
- V = Required gas capacity in S.C.F.M.
- V_a = Required air capacity in S.C.F.M.
- V_L = Required liquid capacity in U.S. gallons per minute.
- G = Specific gravity of gas (air=1) or specific gravity of liquid (water=1) at actual discharge temperature will obtain a safe valve size.
- M = Average molecular weight of vapor.
- P = Relieving pressure in pounds per square inch absolute=set pressure+overpressure+14.7. Minimum overpressure is 3 psi.
- P₁ = Set pressure at inlet, psig.
- P₂ = Back pressure at outlet, psig.
- ΔP = Set pressure + overpressure, psig – back pressure, psig. At 10% overpressure ΔP=1.1P₁ -P₂. Below 30 psig set, ΔP=P₁ +3-P₂.
- T = Inlet temperature absolute (°F+460).
- Z = Compressibility factor corresponding to T and P (if this factor is not available, compressibility correction can be safely ignored by using a value of Z=1.0).
- C = Gas or vapor flow constant. Select from table on page 86 or use the curve and table on page 85.
- k = Ratio of specific heats, C_p/C_v. This value is constant for an ideal gas. If this ratio is unknown, the value k=1.001, C=315 will result in a safe valve size. Isentropic coefficient n may be used instead of k. See curve and table on page 85.
- K_p = Liquid capacity correction factor for overpressures lower than 25%. See curve on page 89. Non-Code equations only.
- K_b = Vapor or gas flow correction factor for constant back pressures above critical pressure. See curve on page 87.
- K_v = Vapor or gas flow factor for variable back pressures. See curve on page 87. BalanSeal valves only.
- K_w = Liquid flow factor for variable and constant back pressures. See curve on page 89. BalanSeal valves only.
- K_u = Liquid viscosity correction factor. See chart on page 90 or curve on page 91.
- K_{sh} = Steam superheat correction factor. See table on page 88.
- K_n = Napier steam correction factor for set pressures between 1500 and 2900 psig. See table on page 88.
- K_d = Coefficient of Discharge, where:

Service Fluid	Coefficient of Discharge When Sizing Using	
	API Effective Areas	ASME Actual Areas
Air, Steam, Vapor & Gas	0.953	0.858
Liquid (2600L, ASME Code)	0.724	0.652
Liquid (2600 Non Code)	0.640	0.576

Sizing

BalanSeal Valves – Variable or Constant Back Pressure

The BalanSeal (balanced bellows) valve is used to prevent corrosion of the guiding surfaces of a pressure relief valve, to confine the lading fluid and prevent contamination, or to make the valve suitable for variable back pressure service. When the BalanSeal valve is under constant or variable back pressure conditions, the valve capacity is affected. Depending on the percentage of maximum back pressure to the flowing pressure of the valve, a factor for the correction of valve capacity is necessary. The effect on valve capacity is different in liquid service than in vapor and gas service, so correction factors vary. In the calculations that follow, use K_v for vapors and gases as shown on page 87 and K_w for liquids as shown on page 89.

When sizing and selecting a BalanSeal valve, follow the same procedures as for conventional valves, but use the following equations that incorporate the correction factors K_v and K_w .

The BalanSeal valve must be used when the variation in back pressure exceeds 10% of set pressure.

Orifice Area Calculations

VAPORS or GASES – Lbs./hr.:

$$A = \frac{W \sqrt{T} \sqrt{Z}}{C K_d P \sqrt{M} K_v}$$

VAPORS or GASES – S.C.F.M.:

$$A = \frac{V \sqrt{G} \sqrt{T} \sqrt{Z}}{1.175 C K_d P K_v}$$

STEAM – Lbs./hr.:

$$A = \frac{W_s}{51.5 K_d P K_v K_{sh} K_n}$$

AIR – S.C.F.M.:

$$A = \frac{V_a \sqrt{T}}{418 K_d P K_v}$$

LIQUIDS – 2600L Series, G.P.M., ASME Code:

$$A = \frac{V_l \sqrt{G}}{38.0 K_d \sqrt{\Delta P} K_w K_u}$$

LIQUIDS – 2600 Series, G.P.M., Non-ASME Code²:

$$A = \frac{V_l \sqrt{G}}{38.0 K_d \sqrt{1.25 (P_1 - P_2)} K_p K_w K_u}$$

2. When back pressure P_2 is variable, use the maximum value.

Gas or Vapor Flow Constant C for Gas or Vapor Related to Ratio of Specific Heats ($k = C_p/C_v$)

k	Constant C	k	Constant C	k	Constant C
1.00	315	1.26	343	1.52	366
1.02	318	1.28	345	1.54	368
1.04	320	1.30	347	1.56	369
1.06	322	1.32	349	1.58	371
1.08	324	1.34	351	1.60	372
1.10	327	1.36	352	1.62	374
1.12	329	1.38	354	1.64	376
1.14	331	1.40	356	1.66	377
1.16	333	1.42	358	1.68	379
1.18	335	1.44	359	1.70	380
1.20	337	1.46	361	2.00	400
1.22	339	1.48	363	2.20	412
1.24	341	1.50	364	—	—

Constant C for Gas or Vapor Related to Ratio of Specific Heats ($k = C_p/C_v$)

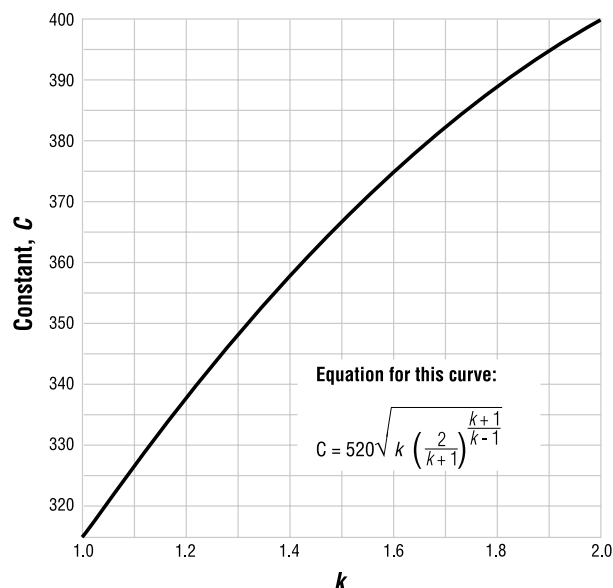

Fluid Data

Fluid	Formula	Molecular Weight	Specific Gravity		k (C _p /C _v)	C (Constant)
			Liquid	Gas		
Acetic Acid	HC ₂ H ₃ O ₂	60.05	1.049	2.073	1.15	332
Acetone	C ₃ H ₆ O	58.08	0.791	–	–	–
Acetylene	C ₂ H ₂	26.04	0.62	0.899	1.26	343
Air	–	28.97	0.86	1	1.4	356
Ammonia	NH ₃	17.03	0.817	0.588	1.33	350
Argon	A	39.94	1.65	1.388	1.67	378
Benzene	C ₆ H ₆	78.11	0.879	2.696	1.12	329
Butane/n-Butane	C ₄ H ₁₀	58.12	0.579	2.006	1.094	326
Carbon Dioxide	CO ₂	44.01	1.101	1.519	1.3	347
Carbon Disulfide	CS ₂	76.13	1.263	2.628	1.21	338
Carbon Monoxide	CO	28	0.814	0.966	1.4	356
Chlorine	Cl ₂	70.9	1.58	2.45	1.36	353
Cyclohexane	C ₆ H ₁₂	84.16	0.779	2.905	1.09	326
Dowtherm A	–	165	1.064	–	–	–
Dowtherm J	–	134	0.931	–	–	–
Ethane	C ₂ H ₆	30.07	0.546	1.04	1.22	339
Ethyl Alcohol (Ethanol)	C ₂ H ₆ O	46.07	0.789	1.59	1.13	330
Ethyl Chloride	C ₂ H ₅ Cl	64.52	0.903	2.227	1.19	336
Ethylene (Ethene)	C ₂ H ₄	28.05	0.566	0.968	1.26	343
Freon 12	CCl ₂ F ₂	120.9	1.35	4.17	1.14	331
Helium	He	4	–	0.138	1.66	377
Hexane	C ₆ H ₁₄	86.17	0.659	2.974	1.06	322
Hydrochloric Acid	HCl	36.5	1.64	–	–	–
Hydrofluoric Acid	HF	20.01	0.92	–	–	–
Hydrogen	H ₂	2.016	0.0709	0.069	1.14	357
Hydrogen Sulfide	H ₂ S	34.07	0.79	1.176	1.32	349
Kerosene	C ₉ H ₂ O	128.3	0.815	–	–	–
Methane	CH ₄	16.04	0.415	0.554	1.31	348
Methyl Alcohol	CH ₃ O	32.04	0.792	1.111	1.2	337
Methyl Chloride	CH ₃ Cl	50.49	0.952	1.743	1.2	337
Natural Gas (typical)	–	19	0.45	0.656	1.27	344
Nitric Acid	HNO ₃	63.02	1.502	–	–	–
Nitrogen	N ₂	28	1.026	0.967	1.4	356
Nitrous Oxide	N ₂ O	44	1.226	1.519	1.3	347
Oxygen	O ₂	32	1.426	1.104	1.4	356
Pentane	C ₅ H ₁₂	72.15	0.631	2.49	1.07	323
Propane	C ₃ H ₈	44.09	0.585	1.522	1.13	330
Styrene	C ₈ H ₈	104.14	0.906	3.6	1.07	323
Sulfur Dioxide	SO ₂	64.06	1.434	2.21	1.29	346
Sulfuric Acid	H ₂ SO ₄	98.08	1.83	–	–	–
Therminol D-12	–	162	0.76	–	–	–
Therminol VP-1	–	166	1.061	–	–	–
Toluene	C ₇ H ₈	92.1	0.87	3.18	1.1	327
Water	H ₂ O	18.02	1	0.622	1.31	348

Sizing Factors for Vapors and Gases

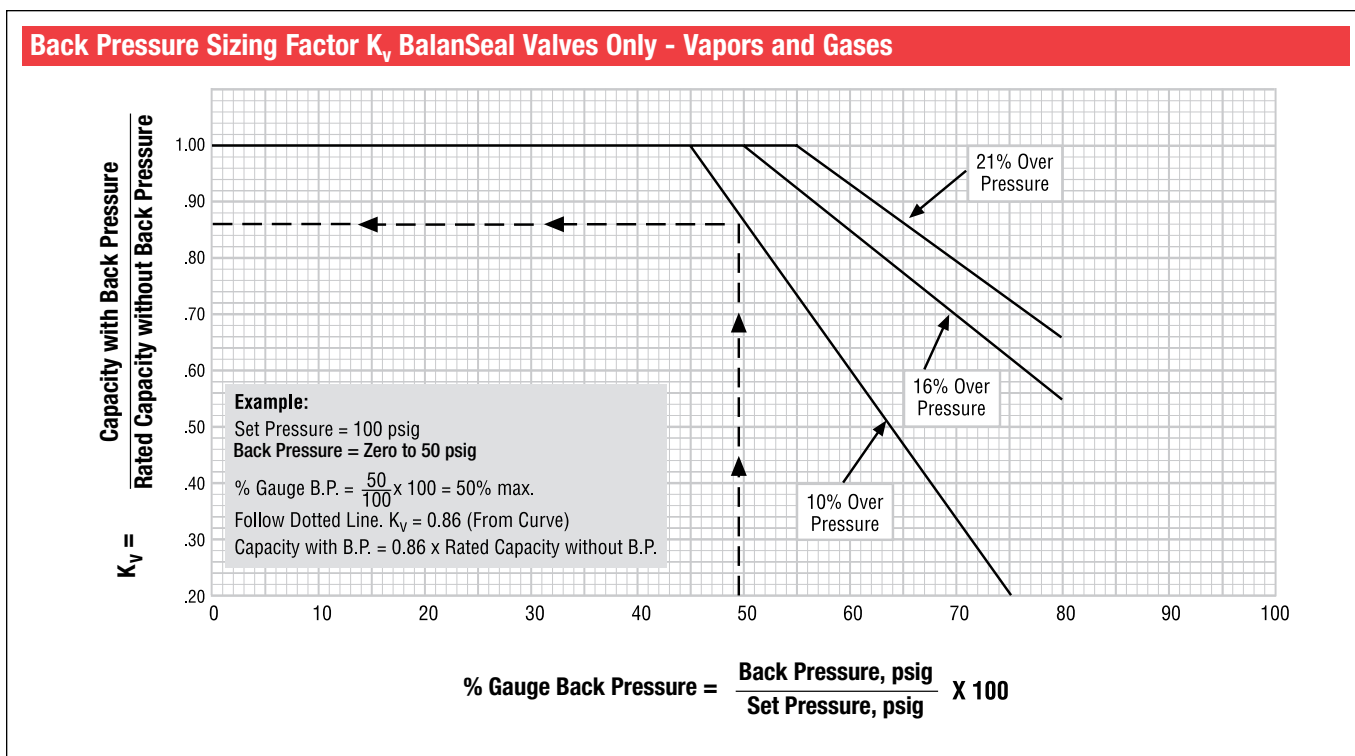
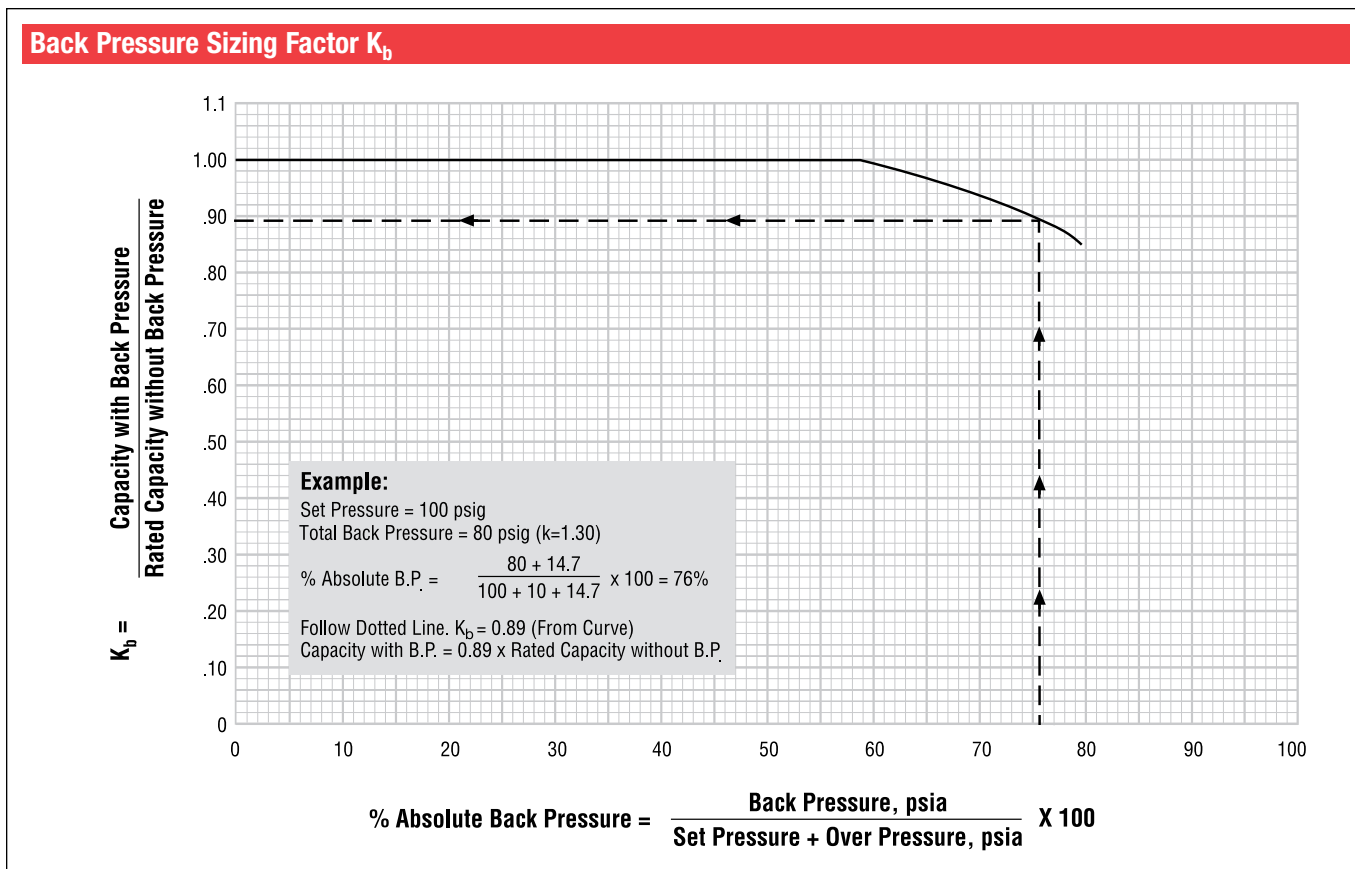



Sizing Factors for Steam

Equation:

$$K_n = \frac{0.1906P-1000}{0.2292P-1061}$$

Where:
 P = relieving pressure, psig

K_n Napier Correction Factor for Set Pressures Between 1500 and 2900 psig at 10% Overpressure

Set Press. psig	K _n	Set Press. psig	K _n	Set Press. psig	K _n	Set Press. psig	K _n	Set Press. psig	K _n	Set Press. psig	K _n	Set Press. psig	K _n	Set Press. psig	K _n	Set Press. psig	K _n	Set Press. psig	K _n	Set Press. psig	K _n	
1500	1.005	1640	1.014	1780	1.025	1920	1.037	2060	1.050	2200	1.066	2340	1.083	2480	1.104	2620	1.128	2760	1.157			
1510	1.005	1650	1.015	1790	1.026	1930	1.038	2070	1.051	2210	1.067	2350	1.085	2490	1.105	2630	1.130	2770	1.159			
1520	1.006	1660	1.016	1800	1.026	1940	1.039	2080	1.052	2220	1.068	2360	1.086	2500	1.107	2640	1.132	2780	1.161			
1530	1.007	1670	1.016	1810	1.027	1950	1.040	2090	1.053	2230	1.069	2370	1.087	2510	1.109	2650	1.134	2790	1.164			
1540	1.007	1680	1.017	1820	1.028	1960	1.040	2100	1.054	2240	1.070	2380	1.089	2520	1.110	2660	1.136	2800	1.166			
1550	1.008	1690	1.018	1830	1.029	1970	1.041	2110	1.055	2250	1.072	2390	1.090	2530	1.112	2670	1.138	2810	1.169			
1560	1.009	1700	1.019	1840	1.030	1980	1.042	2120	1.057	2260	1.073	2400	1.092	2540	1.114	2680	1.140	2820	1.171			
1570	1.009	1710	1.019	1850	1.031	1990	1.043	2130	1.058	2270	1.074	2410	1.093	2550	1.115	2690	1.142	2830	1.174			
1580	1.010	1720	1.020	1860	1.031	2000	1.044	2140	1.059	2280	1.075	2420	1.095	2560	1.117	2700	1.144	2840	1.176			
1590	1.011	1730	1.021	1870	1.032	2010	1.045	2150	1.060	2290	1.077	2430	1.096	2570	1.119	2710	1.146	2850	1.179			
1600	1.011	1740	1.022	1880	1.033	2020	1.046	2160	1.061	2300	1.078	2440	1.098	2580	1.121	2720	1.148	2860	1.181			
1610	1.012	1750	1.023	1890	1.034	2030	1.047	2170	1.062	2310	1.079	2450	1.099	2590	1.122	2730	1.150	2870	1.184			
1620	1.013	1760	1.023	1900	1.035	2040	1.048	2180	1.063	2320	1.081	2460	1.101	2600	1.124	2740	1.152	2880	1.187			
1630	1.014	1770	1.024	1910	1.036	2050	1.049	2190	1.064	2330	1.082	2470	1.102	2610	1.126	2750	1.155	2890	1.189			
																			2900	1.192		

K_{sh} Superheat Correction Factor

Set. Press. psig	Saturated Steam Temp. °F	Total Temperature in Degrees Fahrenheit																																																							
		280	300	320	340	360	380	400	420	440	460	480	500	520	540	560	580	600	620	640	660	680	700	720	740	760	780	800	820	840	860	880	900	920	940	960	980	1000																			
15	250	1.00	1.00	1.00	.99	.99	.98	.98	.97	.96	.95	.94	.93	.92	.91	.90	.89	.88	.87	.86	.86	.85	.84	.83	.83	.82	.81	.81	.80	.79	.79	.78	.78	.77	.76	.76	.75	.75	.75																		
20	259	1.00	1.00	1.00	.99	.99	.98	.98	.97	.96	.95	.94	.93	.92	.91	.90	.89	.88	.87	.86	.86	.85	.84	.83	.83	.82	.81	.81	.80	.79	.79	.78	.78	.77	.76	.76	.75	.75	.75																		
40	287	-	1.00	1.00	1.00	.99	.99	.98	.97	.96	.95	.94	.93	.92	.91	.90	.89	.88	.87	.86	.86	.85	.84	.83	.83	.82	.81	.81	.80	.79	.79	.78	.78	.77	.76	.76	.75	.75	.75																		
60	308	-	-	1.00	1.00	.99	.99	.98	.97	.96	.95	.94	.93	.92	.91	.90	.89	.88	.87	.86	.86	.85	.84	.83	.83	.82	.81	.81	.80	.79	.79	.78	.78	.77	.76	.76	.75	.75	.75																		
80	324	-	-	-	1.00	1.00	.99	.99	.98	.97	.96	.94	.93	.92	.91	.90	.89	.89	.88	.87	.86	.85	.84	.83	.83	.82	.81	.81	.80	.79	.79	.78	.78	.77	.76	.76	.75	.75	.75																		
100	338	-	-	-	-	1.00	1.00	.99	.98	.97	.96	.95	.94	.93	.92	.91	.90	.89	.88	.87	.86	.85	.84	.83	.83	.82	.81	.81	.80	.79	.79	.78	.78	.77	.76	.76	.75	.75	.75																		
120	350	-	-	-	-	-	1.00	1.00	.99	.98	.97	.96	.95	.94	.93	.92	.91	.90	.89	.88	.87	.86	.85	.84	.83	.83	.82	.81	.81	.80	.79	.79	.78	.78	.77	.76	.76	.75	.75																		
140	361	-	-	-	-	-	-	1.00	.99	.98	.96	.95	.94	.93	.92	.91	.90	.89	.88	.87	.86	.85	.84	.83	.83	.82	.81	.81	.80	.79	.79	.78	.78	.77	.76	.76	.75	.75	.75																		
160	371	-	-	-	-	-	-	-	1.00	.99	.98	.97	.95	.94	.93	.92	.91	.90	.89	.88	.87	.86	.85	.84	.83	.83	.82	.81	.81	.80	.79	.79	.78	.78	.77	.76	.76	.75	.75	.75																	
180	380	-	-	-	-	-	-	-	-	1.00	.99	.98	.97	.96	.95	.93	.92	.91	.90	.89	.88	.87	.86	.85	.84	.83	.83	.82	.81	.81	.80	.79	.79	.78	.78	.77	.76	.76	.75	.75																	
200	388	-	-	-	-	-	-	-	-	-	1.00	.99	.99	.97	.96	.95	.93	.92	.91	.90	.89	.88	.87	.86	.86	.85	.84	.83	.83	.82	.81	.81	.80	.79	.79	.78	.78	.77	.76	.76	.75																
220	395	-	-	-	-	-	-	-	-	-	-	1.00	.99	.99	.98	.96	.95	.93	.92	.91	.90	.89	.88	.87	.86	.85	.84	.83	.83	.82	.81	.81	.80	.79	.79	.78	.78	.77	.76	.76	.75																
240	403	-	-	-	-	-	-	-	-	-	-	-	1.00	.99	.98	.97	.95	.94	.93	.92	.91	.90	.89	.88	.87	.86	.85	.84	.83	.83	.82	.81	.81	.80	.79	.79	.78	.78	.77	.76	.76	.75															
260	409	-	-	-	-	-	-	-	-	-	-	-	-	1.00	.99	.98	.97	.96	.94	.93	.92	.91	.90	.89	.88	.87	.86	.85	.84	.83	.83	.82	.81	.81	.80	.79	.79	.78	.78	.77	.76	.76	.75														
280	416	-	-	-	-	-	-	-	-	-	-	-	-	-	1.00	1.00	.99	.97	.96	.95	.93	.92	.91	.90	.89	.88	.87	.86	.85	.84	.83	.83	.82	.81	.81	.80	.79	.79	.78	.78	.77	.76	.76	.75													
300	422	-	-	-	-	-	-	-	-	-	-	-	-	-	-	1.00	.99	.98	.96	.95	.93	.92	.91	.90	.89	.88	.87	.86	.85	.84	.83	.83	.82	.81	.81	.80	.79	.79	.78	.78	.77	.76	.76	.75													
350	436	-	-	-	-	-	-	-	-	-	-	-	-	-	-	-	1.00	.99	.97	.96	.94	.93	.92	.91	.90	.89	.88	.87	.86	.85	.84	.83	.83	.82	.81	.81	.80	.79	.79	.78	.78	.77	.76	.76	.75												
400	448	-	-	-	-	-	-	-	-	-	-	-	-	-	-	-	-	1.00	.99	.98	.96	.95	.93	.92	.91	.90	.89	.88	.87	.86	.85	.84	.83	.83	.82	.81	.81	.80	.79	.79	.78	.78	.77	.76	.76	.75											
450	460	-	-	-	-	-	-	-	-	-	-	-	-	-	-	-	-	-	1.00	.99	.98	.97	.96	.94	.93	.92	.91	.90	.89	.88	.87	.86	.85	.84	.83	.83	.82	.81	.81	.80	.79	.79	.78	.78	.77	.76	.76	.75									
500	470	-	-	-	-	-	-	-	-	-	-	-	-	-	-	-	-	-	-	1.00	.99	.98	.96	.94	.93	.92	.91	.90	.89	.88	.87	.86	.85	.84	.83	.83	.82	.81	.81	.80	.79	.79	.78	.78	.77	.76	.76	.75									
550	480	-	-	-	-	-	-	-	-	-	-	-	-	-	-	-	-	-	-	-	1.00	.99	.97	.95	.94	.92	.91	.90	.89	.88	.87	.86	.85	.84	.83	.83	.82	.81	.81	.80	.79	.79	.78	.78	.77	.76	.76	.75									
600	489	-	-	-	-	-	-	-	-	-	-	-	-	-	-	-	-	-	-	-	-	1.00	.99	.98	.96	.94	.93	.92	.91	.90	.89	.88	.87	.86	.85	.84	.83	.83	.82	.81	.81	.80	.79	.79	.78	.78	.77	.76	.76	.75							
650	497	-	-	-	-	-	-	-	-	-	-	-	-	-	-	-	-	-	-	-	-	-	1.00	.99	.97	.95	.94	.92	.91	.90	.89	.88	.87	.86	.85	.84	.83	.83	.82	.81	.81	.80	.79	.79	.78	.78	.77	.76	.76	.75							
700	506	-	-	-	-	-	-	-	-	-	-	-	-	-	-	-	-	-	-	-	-	-	-	1.00	.99	.97	.95	.94	.92	.91	.90	.89	.88	.87	.86	.85	.84	.83	.83	.82	.81	.81	.80	.79	.79	.78	.78	.77	.76	.76	.75						
750	513	-	-	-	-	-	-	-	-	-	-	-	-	-	-	-	-	-	-	-	-	-	-	-	1.00	1.00	.98	.96	.94	.93	.92	.91	.90	.89	.88	.87	.86	.85	.84	.83	.83	.82	.81	.81	.80	.79	.79	.78	.78	.77	.76	.76	.75				
800	520	-	-	-	-	-	-	-	-	-	-	-	-	-	-	-	-	-	-	-	-	-	-	-	-	-	1.00	.99	.97	.95	.94	.92	.91	.90	.89	.88	.87	.86	.85	.84	.83	.83	.82	.81	.81	.80	.79	.79	.78	.78	.77	.76	.76	.75			
850	527	-	-	-	-	-	-	-	-	-	-	-	-	-	-	-	-	-	-	-	-	-	-	-	-	-	-	-	1.00	.99	.98	.96	.94	.93	.92	.91	.90	.89	.88	.87	.86	.85	.84	.83	.83	.82	.81	.81	.80	.79	.79	.78	.78	.77	.76	.76	.75
900	533	-	-	-	-	-	-	-	-	-	-	-	-	-	-	-	-	-	-	-	-	-	-	-	-	-	-	-	-	-	1.00	.99	.97	.95	.94	.92	.91	.90	.89	.88	.87																

Sizing Factors for Liquids

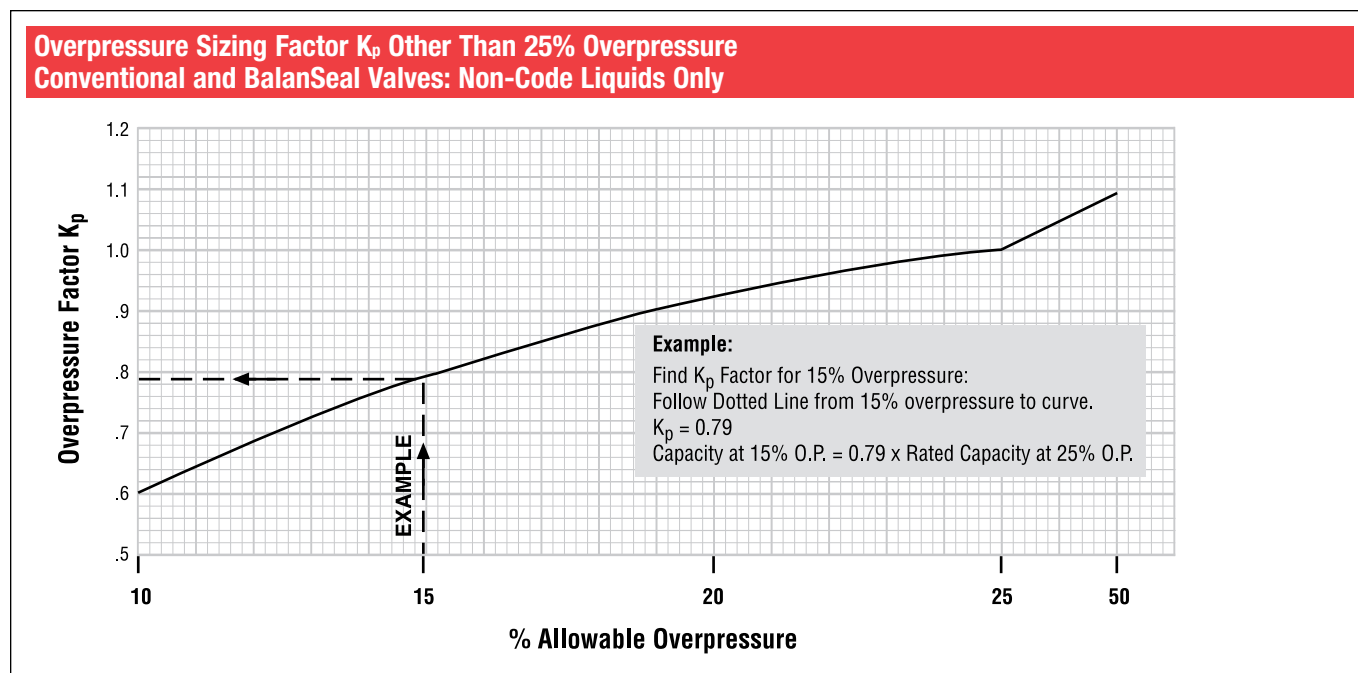
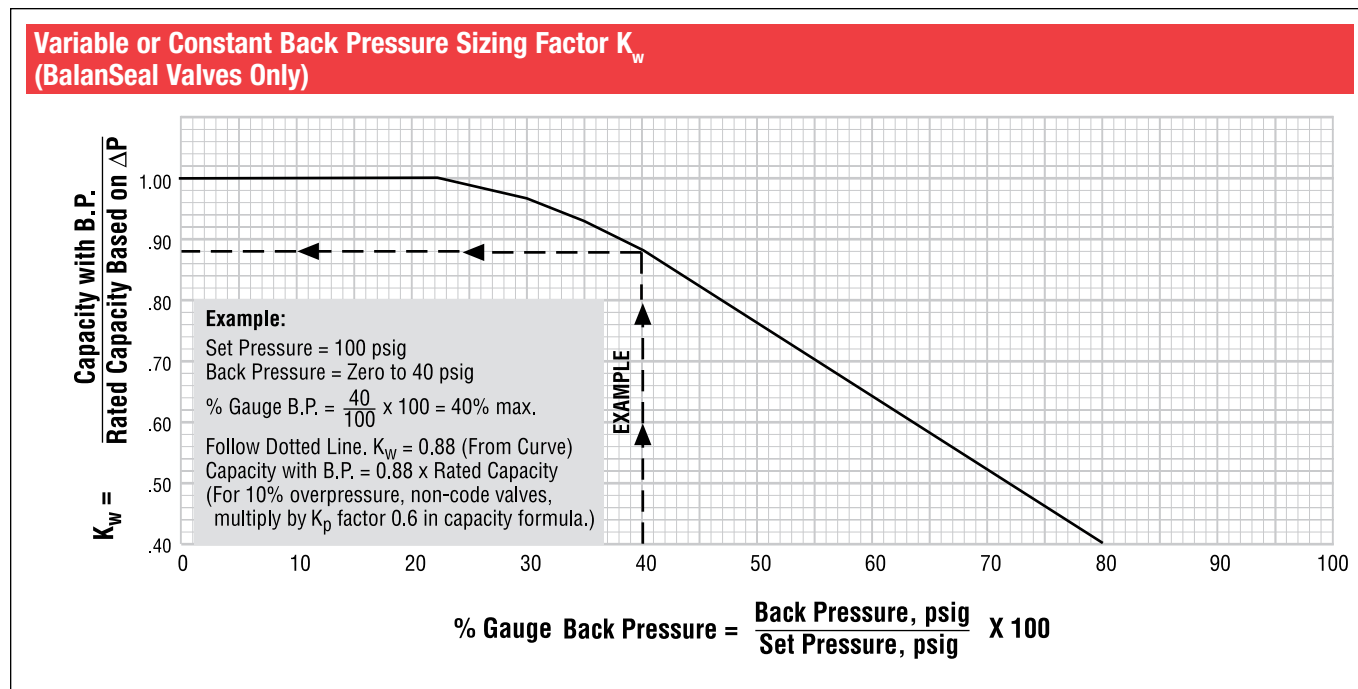

Note: Pressure relief valve liquid capacities cannot be predicted by a general curve for overpressures below 10%.

Sizing Factors for Liquids

Viscosity Correction, Chart Sizing Method

Sizing Method

Since the viscosity correction factor depends on the actual orifice area, direct solution is not possible and a trial orifice size must be found before the K_u can be determined accurately.

Example: ASME Code liquid application. If non-ASME Code is required, substitute appropriate equation

Viscosity-Saybolt Universal Secs.....	1250 SSU@100°F
Capacity Required	800 gpm
Set Pressure	100 psig
Constant Back pressure.....	10 psig
Differential Pressure (1.25 P ₁ -P ₂)	115 psig
Allowable Overpressure25%
Specific Gravity	0.98@100°F
Relieving Temperature	100°F

Step 1 Calculate Trial Orifice: Calculate the trial orifice area from the liquid equation on page 84:

$$A = \frac{V_L \sqrt{G}}{38.0 K_d \sqrt{\Delta P} K_u} = \frac{800 (0.99)}{38.0 (0.652) \sqrt{124.7-10(1)}} = 2.98 \text{ sq. in. Actual Area}$$

The viscosity of the liquid may reduce the velocity and capacity enough to require a larger orifice size than the usual liquid service capacity equation would indicate. Use this simplified viscosity chart and the K_u viscosity correction factors obtainable from it to properly size relief valves intended for viscous liquid service. Equations and graphs used in preparing this chart reflect conservative engineering data on this subject.

For viscous liquid service, it is advisable to allow 25% over-pressure where permissible, to size conservatively, and to consider the use of the bellows and/or steam jacketed bodies for the purpose of isolating the moving parts and to prevent freezing of the lading fluid.

If BalanSeal valve construction is used and variable back pressure conditions exist, use the maximum back pressure to determine P_2 in the equation, and correct K_w factor. See curve on page 89. Use the following equation:

$$A = \frac{V_L \sqrt{G}}{38.0 K_d \sqrt{\Delta P} K_w K_u}$$

Select the next larger orifice size or an M orifice with 4.0 sq. in. orifice area. This should be about 20% greater than the calculated area to allow for reduction of capacity due to viscosity correction factor K_u .

Step 2 Use Chart to Find K_u : Enter the Viscosity Correction Chart from the left, reading 1250 SSU. Follow the example line horizontally to the required 800 gpm. Drop vertically to the selected trial orifice M, and proceed horizontally right to the K_u scale, reading $K_u = 0.955$.

Step 3 Verify Orifice Selection: This chart is designed to minimize the trial and error required for solution. Note that the exit from the chart is from the orifice line to the K_u scale. By looking vertically, the next larger or smaller orifice show alternate values of the A term and the corresponding K_u term without repeating all the steps.

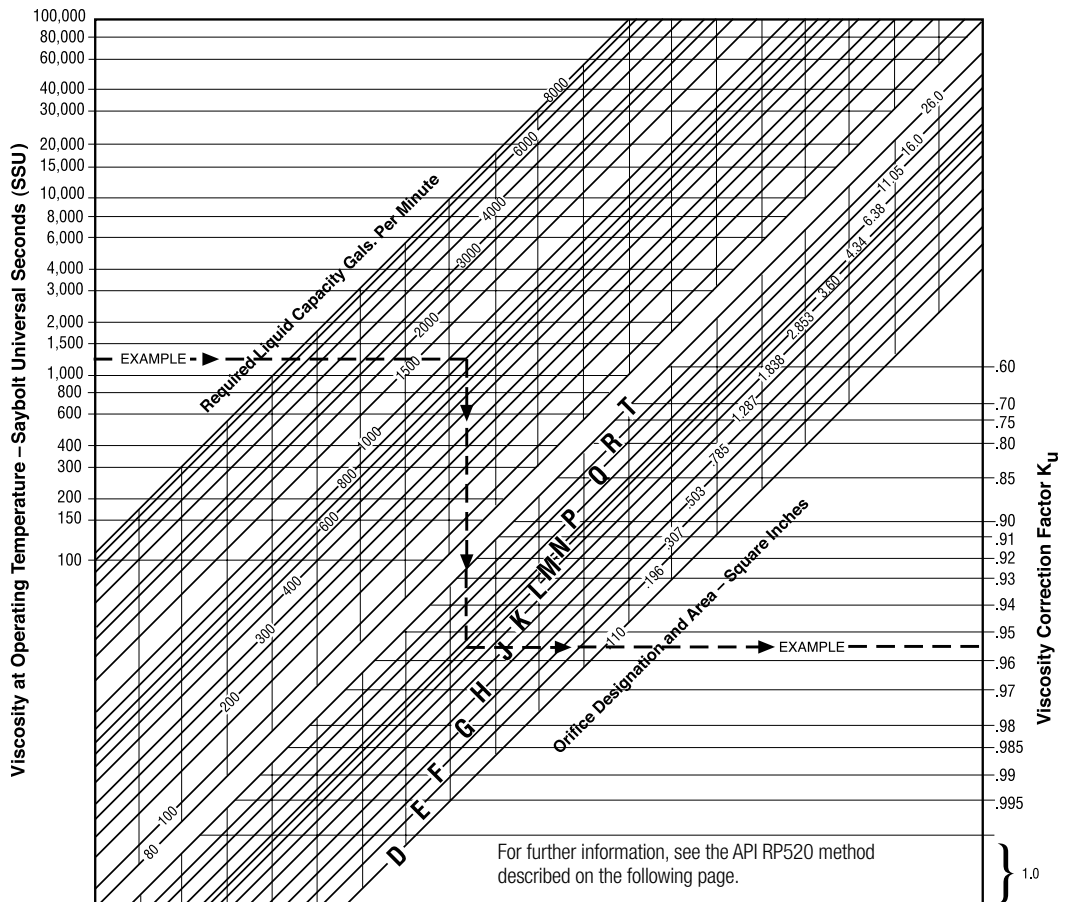

For further information, see the API RP520 method described on the following page.

Sizing Factors for Liquids

Viscosity Correction, Reynold's Number Method of API RP520

As an alternative to the sizing method discussed on the previous page, you may use the method given in API RP520 for sizing viscous liquids.

When a relief valve is sized for viscous liquid services, it is suggested that it be sized first as a nonviscous type application in order to obtain a preliminary required discharge area, A. From manufacturer's standard orifice sizes, the next larger orifice size should be used to determine the Reynold's number R from either one of the following:

$$R = \frac{V_L (2800G)}{\mu \sqrt{A}} \quad \text{or} \quad R^* = \frac{12700 V_L}{U \sqrt{A}}$$

*Use of this equation is not recommended for viscosities less than 100 SSU.

After the value of R is determined, the factor K_v^{**} is obtained from the graph. Factor K_v is applied to correct the preliminary required discharge area. If the corrected area exceeds the chosen standard orifice area, the calculations should be repeated using the next larger standard orifice size.

** K_v of API = K_d of Farris Engineering

Nomenclature

V_L = Flow rate at the flowing temperature in the U.S. gallon per minute.

G = Specific gravity of the liquid at the flowing temperature referred to water = 1.00 at 70°F.

μ = Absolute viscosity at the flowing temperature in centipoises.

A = Discharge area in square inches from manufacturer's standard orifice areas¹.

U = Viscosity at the flowing temperature in Saybolt Universal Seconds.

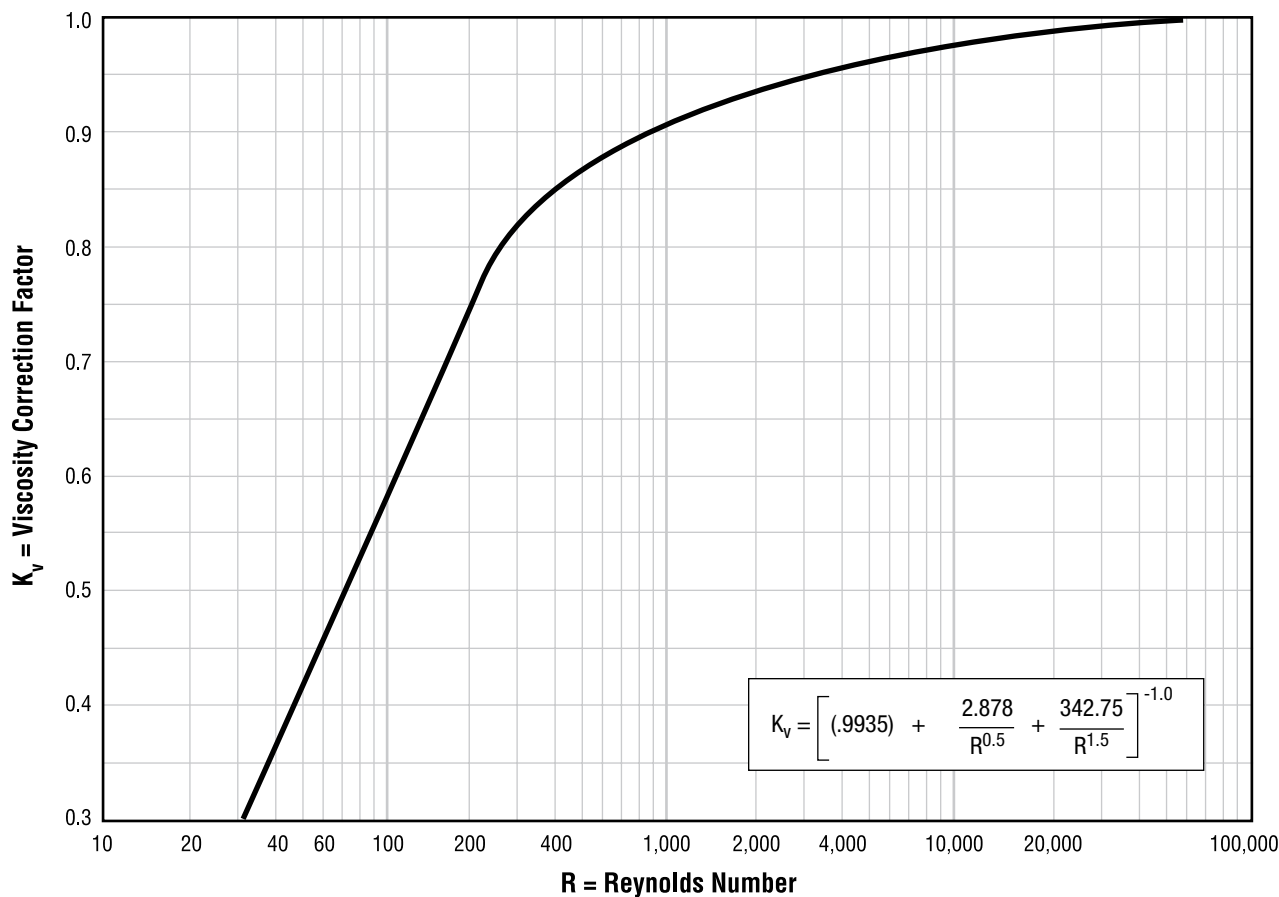

General Notes:

1. Select using either API effective area or ASME actual area depending on the sizing method being used.

Conversion Factors

To find desired value, multiply "Given" value by factor below

Pressure Conversion				
Given	psi	kPa	Bar	kg/cm ²
psi	1	6.8948	0.0689	0.0703
kPa	0.145	1	0.01	0.0102
Bar	14.504	100	1	1.0197
kg/cm ²	14.223	97.905	0.9	1

Liquid Flow Rate Conversion				
Given	gpm	bbl/day	l/min	m ³ /hr
gpm	1	34.29	3.785	0.2271
bbl/day	0.02917	1	0.1104	0.006624
l/min	0.2642	9.057	1	0.06
m ³ /hr	4.403	151	16.667	1

Mass Conversion				
Given	lb	tons	kg	tonnes
lb	1	0.0005	0.4536	0.00045
tons	2000	1	907.18	0.90718
kg	2.2046	0.0011	1	0.001
tonnes	2204.6	1.102	1000	1

Viscosity Conversion				
Given	cP	g/cm-s	centistoke	SSU
cP	1	0.01	1/G	4.63/G
g/cm-s	100	1	100/G	463/G
centistoke	G	(0.01)G	1	4.63
SSU	(0.216)G	(21.6)G	0.216	1

where G is liquid specific gravity

Volume Conversion				
Given	ft ³	m ³	gal	liter
ft ³	1	0.02832	7.481	28.32
m ³	35.31	1	264.2	1000
gal	0.1337	0.00379	1	3.785
liter	0.03532	0.001	0.2642	1

Density Conversion				
Given	lb/ft ³	kg/m ³	g/cm ³	lb/gal
lb/ft ³	1	16.018	0.016	0.1337
kg/m ³	0.0624	1	0.001	0.0083
g/cm ³	62.428	1000	1	8.345
lb/gal	7.481	119.83	0.1198	1

Area Conversion				
Given	in ²	ft ²	mm ²	cm ²
in ²	1	0.00694	645.16	6.4516
ft ²	144	1	92903	929.03
mm ²	0.00155	1.08E-05	1	0.01
cm ²	0.155	0.0011	100	1

Temperature Conversion	
Fahrenheit (F) =	(1.8 x C) + 32
Celsius (C) =	0.555 x (F - 32)
Rankin (R) =	F + 459.67
Kelvin (K) =	C + 273.15

Length Conversion				
Given	ft	in	mm	m
ft	1	12	304.8	0.3048
in	0.0833	1	25.4	0.0254
mm	0.0033	0.0394	1	0.001
m	3.281	39.37	1000	1

Miscellaneous Conversions		
From	To	Multiply By
Specific Gravity-Gas	Molecular Wt-Gas	28.97
Density-Liq	Specific Gravity-Liq	1/(p Water)

Farris Engineering Products

Process Pressure Relief Valves

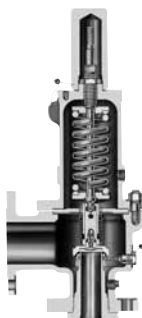

SERIES 2600/2600L

- ASME NB Certified: Air, Steam & Water
- Sizes: 1" x 2" to 20" x 24"
- Pressure Range: 15 psig to 6000 psig
- Temperature Range: -450°F to +1500°F
- Materials: Carbon Steel, Stainless Steel, Monel & Hastelloy C
- Options: Balanced Bellows, O-Ring Seat, Open Bonnet
- CE Approved

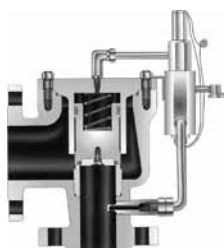

SERIES 3800 Pilot Operated

- ASME NB Certified: Air, Steam & Water
- Sizes: 1" x 2" to 12" x 16"
- Pressure Range: 15 psig to 6170 psig
- Temperature Range: -450°F to +500°F
- Materials: Carbon Steel, Stainless Steel, Monel & Hastelloy C
- Actuation: Snap and Modulating Controls
- Options: Field Test Connections, Reverse Flow Preventer, Remote Depressurizing & Auxiliary Filters
- CE Approved

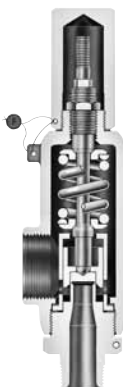

SERIES 2700

- ASME NB Certified: Air, Steam & Water
- Sizes: ½" x 1" to 1½" x 2½"
- Pressure Range: 15 psig to 6500 psig
- Temperature Range: -450°F to +750°F
- Materials: Carbon Steel, Stainless Steel, Monel & Hastelloy C
- Options: Balanced Design, O-Ring Seats, Flanged, Socket Weld, Welding Nipple, & Sanitary Connections
- CE Approved

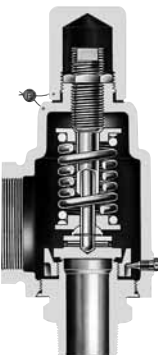

SERIES 2850/2856

- ASME NB Certified: Air & Steam
- Sizes: ¾" x 1" to 1½" x 2" (2850)
¾" x 1¼" to 2" x 3" (2856)
- Pressure Range: 15 psig to 300 psig
- Temperature Range: -20° F to +750°F (2850)
-450° F to +400°F (2856)
- Materials: Stainless Steel Body & Trim
Steel Bonnet (2850) Brass Body & Trim,
Bronze Bonnet (2856)

Steam Safety Valves

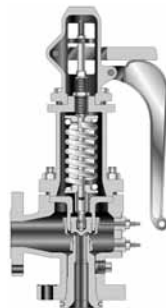

SERIES 4200

- ASME NB Section I & VIII Certified: Steam & Air
- Sizes 1¼" x 1½" to 6" x 8"
- Pressure Range: 15 psig to 1000 psig
- Temperature Range: -20°F to +1000°F
- Materials: Carbon Steel, Stainless Steel, Chrome-Moly
- Options: Test Gag
- CE Approved

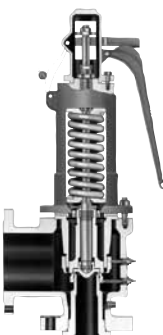

SERIES 6400/6600

- ASME NB Section I & VIII Certified: Steam & Air
- Sizes: 1" x 2" to 4" x 6"
- Pressure Range: 15 psig to 1500 psig
- Temperature Range: -20°F to +1000°F
- Materials: Carbon Steel, Stainless Steel, Chrome-Moly
- Options: Closed Bonnet (6600) & Test Gag

Special Purpose Pressure Relief Valves

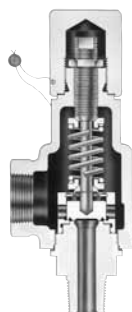

SERIES 1890/1896M

- ASME NB Certified: Air, Steam & Water
- Sizes: ½" x 1" & ¾" x 1" (1890)
½" x ¾" & ¾" x ¾" (1896M)
- Pressure Range: 15 psig to 800 psig (1890) 15 psig to 300 psig (1896M)
- Temperature Range: -20°F to +750°F (1890) -450°F to +400°F (1896M)
- Materials: Stainless Steel Body & Trim (1890) Brass Body & Trim, Bronze Bonnet (1896M)

*Other materials available upon request. Please consult the factory.

Farris Engineering Products and Services



The following is a list of Farris approvals currently on record:

- ASME "V", "UV" and "NV"
- National Board "NB" approval
- ISO 9001-2008
- US Coast Guard
- PED 97/23/EC (European Pressure Equipment Directive)
- ATEX 94/9/EC (European Potentially Explosive Atmospheres)
- B51 CRN (Canadian Registration)
- China Safety Quality License
- Russian GOSH-R and GGNT (Russian Certification and Permits)
- First Point Assessment Limited
- Nuclear – 10 CFR 50 Appendix B, NCA-4000, NQA-1, N285.0

Process Pressure Relief Valves

Series 2600	ASME NB Certified for Air, Steam and Water
Series 3800	ASME NB Certified for Air, Steam and Water
Series 2700	ASME NB Certified for Air, Steam and Water
Series 1890/1896M	ASME NB Certified for Air, Steam and Water
Series 2850/2856	ASME NB Certified for Air and Steam
Series 88/89	ASME NB Certified for Air and Steam
Series 570	ASME NB Certified for Air and Steam
Series 69	Liquid Service
Series 140	Air Service

Steam Safety Valves

Series 4200	ASME NB Certified for Steam – Section I & VIII
Series 6400/6600	ASME NB Certified for Steam – Section I & VIII
Series 560	ASME NB Certified for Steam – Section I & VIII

Nuclear Pressure Relief Valves

Series 4700/4700L	ASME NB Section III, Division 1 Class I, II & III
Series 2700/3700	ASME NB Section III, Division 1 Class I, II & III
Series 2600/2600L	ASME NB Section III, Division 1 Class I, II & III
Series 3800	ASME NB Section III, Division 1 Class I, II & III

SizeMaster™ Mark IV

Pressure Relief Valve Engineering Software for Sizing and Selection

FAST Centers (Farris Authorized Service Team)

- Worldwide Network of Service Centers with Factory Trained Technicians
- Local Inventory with 24 hour a day / 7 day a week support
- Access to Worldwide Farris Inventory through the Web
- ASME/National Board approved Assembly & Test Facilities
- Application, Sizing & Selection Support



10195 Brecksville Road, Brecksville, OH 44141 USA • Telephone: 440-838-7690 • Fax: 440-838-7699 • <http://farris.cwfc.com>

Facilities: Brecksville, Ohio, USA; Brantford, Ontario; Edmonton, Alberta, Canada; Bridport, Dorset, UK; Delhi, India; Tianjin, China

Offices Worldwide: For a listing of our global sales network, visit our website at <http://farris.cwfc.com>.

While this information is presented in good faith and believed to be accurate, Farris Engineering, division of Curtiss-Wright Flow Control Corporation, does not guarantee satisfactory results from reliance on such information. Nothing contained herein is to be construed as a warranty or guarantee, expressed or implied, regarding the performance, merchantability, fitness or any other matter with respect to the products, nor as a recommendation to use any product or process in conflict with any patent. Farris Engineering, division of Curtiss-Wright Flow Control Corporation, reserves the right, without notice, to alter or improve the designs or specifications of the products described herein.