

Technical Datasheet

DIN Ball Valves

316
340

JC
VALVES

The quality option

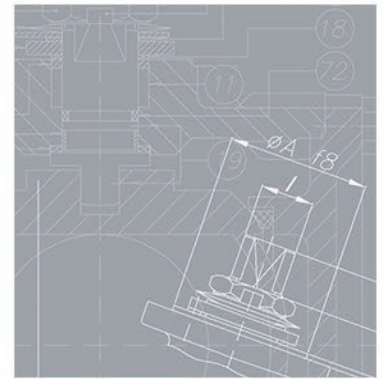

DIN Ball Valves Floating



2014/68/EV



TA-LUFT



FUGITIVE
EMISSIONS
EN-ISO 15848-1
TALUFT / VDI 2440



- Valve design: Full Bore EN 1983
- Body design: EN 12516
- Shell thickness: EN ISO 17292
- Flanges: DIN 2501 / EN 1092-1
- Face to face dimensions: EN 558 Series 1
- Marking: EN 19 / CE - PED / MSS SP25
- Pressure testing: EN 12266
- Shell finishing quality: MSS SP 55
- ISO 5211

Certifications

Company Certifications

- ISO9001 Quality Management System
- ISO14001 Environmental Management System
- AD2000-Merkblatt W0/A4

Product Certificates

- Fire Safe API 607, ISO 10497, API 6FA
- Fugitive Emissions ISO 15848 TA LUFT (VDI 2440)
- PED 2014/68/EU - CE marking
- ATEX 2014/34/EU- (II2GD)
- Russian Federation Certificate TRCU 10, TRCU 12, TRCU 32
- Food processing and pharmaceutical industry FDA, USP CLASS VI COMPLIANCE (CE 1935/2004)
- Safety Integrity Level (SIL) LEVEL 3 IEC 61508
- Valves for gas distribution with maximum operating pressure 16 bar EN 13774 type approval.
- Tanks for the transport of dangerous goods-Tank equipment for the transport of liquid chemicals and liquefied gases - Product discharge and air inlet valves EN 14432
- German type test certificate A216-16

DIN Ball Valves Fl o a t i n g

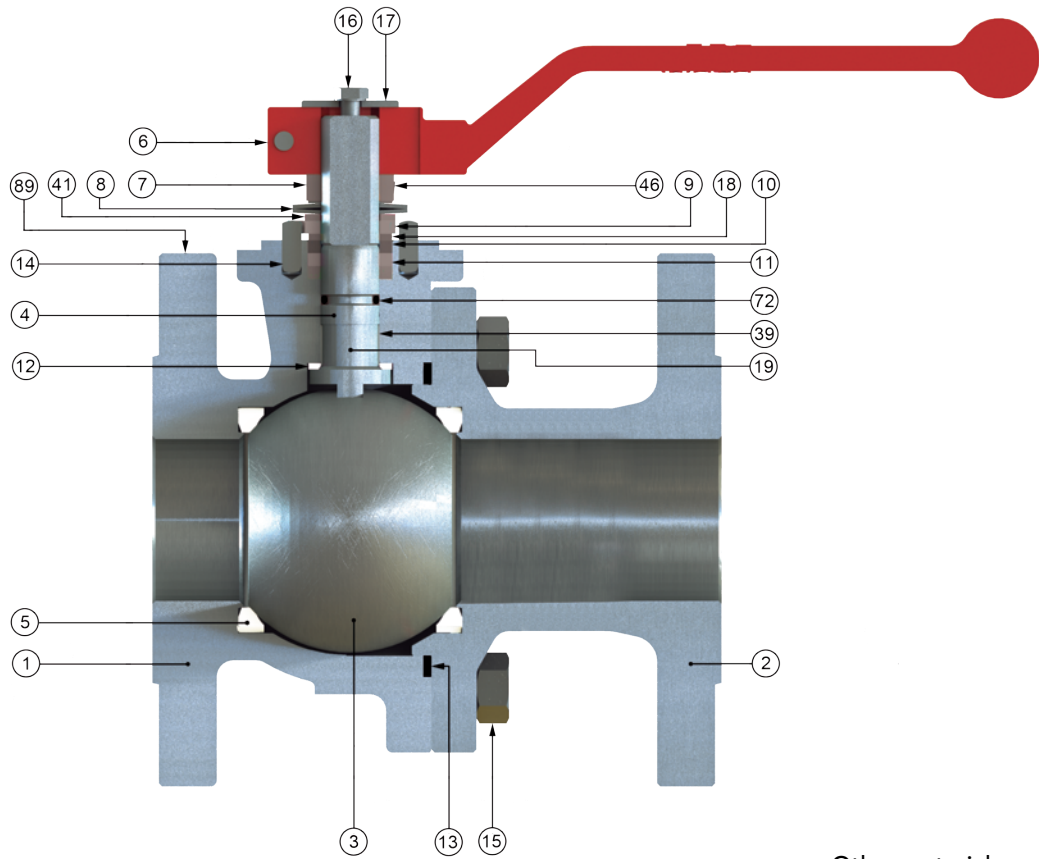

Other materials upon request

Item	Description	Material	
		A.I.T	I.I.T
1 / 2	Body / Body Connector	1.0619	1.4408
3	Ball	ASTM A351 Gr. CF8M (DN 15 : 25 ASTM A 479 Tp.316)	
4	Stem	ASTM A 479 Tp.316	
5	Seat ring	PTFE	
6	Wrench	A 216 Gr. WCB	
7	Gland nut	Zinc plated Carbon St.	AISI 303
8	Disk spring	Carbon St.	A 666 Tp.301
9	Stop plate	Carbon St.	AISI 304
10	Gland	AISI 303	AISI 316
11	Gland packing	Graphite	
12	Stem thrust seal	25% G.F. PTFE	
13	Body connector seal	SPW AISI 316L + PTFE + Graphite	
14	Stop pin	Carbon St.	Stainless St.
15	Bolt	8.8 Zinc Bichromated	A4-70
16	Bolt	DIN 933 A4-70	
17	Washer	AISI 304	
18	Thrust washer	25% G.F. PTFE	
19	Antistatic device	Stainless St.	
39	Stem bushing (DN 25 to DN 200)	25% G.F. PTFE	
41	Spacer (DN 32 to 200)	Carbon St.	AISI 304
46	Washer	AISI 304	
72	O-Ring	FKM	
89	Identification Plate	Stainless St.	

DIN Ball Valves

F l o a t i n g

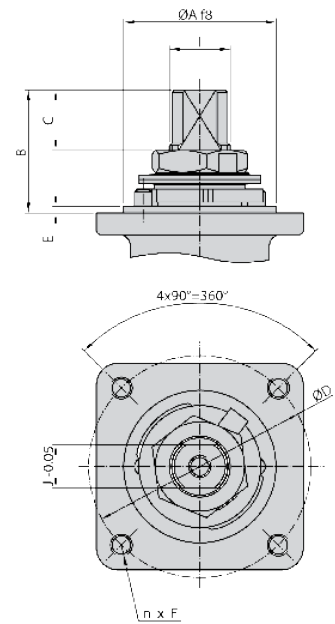
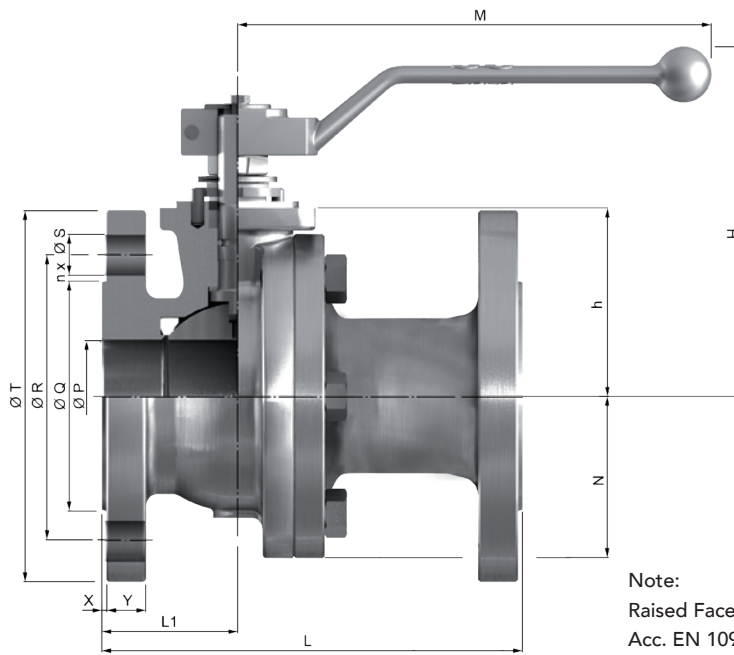

Note:
 Raised Face.- Rz: 12.5 - 50
 Acc. EN 1092-1:2001

* Weight in Kg * Dimensions in mm

Series 316 (PN 16)

DN	ØP	L	L1	ØQ	ØR	n x ØS	ØT	X	Y	h	H	M	N	WEIGHT	Kv
65	65	290	75,5	122	145	4x18	185	3	18	97	169	348	---	18,3	550
80	80	310	82	138	160	8x18	200	3	20	111	207	445	---	24	1000
100	100	350	90,5	158	180	8x18	220	3	20	133	232	495	118	36	1650
125	125	400	120	188	210	8x18	250	3	22	156	265	698	138	58	3000
150	151	480	135	212	240	8x22	285	3	22	183	298	698	160	81	4200
200	203	600	200	268	295	12x22	340	3	24	233	353	868	208	---	---

Series 340 (PN 40)

DN	ØP	L	L1	ØQ	ØR	n x ØS	ØT	X	Y	h	H	M	N	WEIGHT	Kv
15	15	130	53	45	65	4x14	95	2	16	46	111	164	---	3	20
20	20	150	52	58	75	4x14	105	2	18	53	118	164	---	3,8	40
25	25	160	48,5	68	85	4x14	115	2	18	58	130	164	---	5,2	75
32	32	180	54	78	100	4x18	140	2	18	66,5	131	210	---	7,6	130
40	40	200	55	88	110	4x18	150	3	18	76	148	213	---	9,6	170
50	50	230	61	102	125	4x18	165	3	20	83,5	155	213	---	12,9	270
65	65	290	75,5	122	145	8x18	185	3	22	97	169	348	---	18,5	550
80	80	310	74,5	138	160	8x18	200	3	24	111	207	445	---	25	1000
100	100	350	91	162	190	8x22	235	3	24	133	232	495	118	39	1650
125	125	400	120	188	220	8x26	270	3	26	156	265	698	138	63	3000
150	151	480	135	218	250	8x26	300	3	28	183	298	698	160	87	4200

Actuator Connection

DN	ISO 5211	ØA	B	C	ØD	n x F	E	I	J
15	F05	35	11,2	5	50	4x M6	1,5	M12x1,5	9
20	F05	35	14,7	8,5	50	4x M6	1,5	M12x1,5	9
25	F05	35	22,7	9,5	50	4x M6	1,5	M12x1,5	9
32	F05	35	32	13	50	4x M6	1,5	M16x1,5	12
40	F07	55	41,5	18,3	70	4x M8	3	M18x1,5	13
50	F07	55	41,5	18,3	70	4x M8	3	M18x1,5	13
65	F07	55	44	18,6	70	4x M8	3	M22x1,5	16
80	F10	70	44,5	18,6	102	4x M10	3	M25x1,5	18
100	F10	70	56,5	27,8	102	4x M10	3	M28x1,5	20
125	F12	85	56	24,8	125	4x M12	3	M35x2	25
150	F12	85	68	37,1	125	4x M12	3	M40x2	29
200	F14	100	72	36,5	140	4x M16	4	M45x2	32

Differential Pressure 16 bar

DN	BTO	RTO	ETO	BTC	RTC	ETC	MAST
15	-	-	-	-	-	-	-
20	-	-	-	-	-	-	-
25	-	-	-	-	-	-	-
32	-	-	-	-	-	-	-
40	-	-	-	-	-	-	-
50	-	-	-	-	-	-	-
65	61	31	37	46	31	49	176
80	97	49	58	73	49	78	246
100	133	67	80	100	67	106	305
125	226	113	136	170	113	181	607
150	320	160	192	240	160	256	974
200	694	347	416	521	347	555	1387

Differential Pressure 40 bar

DN	BTO	RTO	ETO	BTC	RTC	ETC	MAST
15	11	6	7	8	6	9	26
20	14	7	8	11	7	11	26
25	20	10	12	15	10	16	26
32	25	13	15	19	13	20	69
40	33	17	20	25	17	26	85
50	46	23	28	35	23	37	85
65	66	33	40	50	33	53	176
80	116	58	70	87	58	93	246
100	171	86	103	128	86	137	305
125	283	142	170	212	142	226	607
150	463	232	278	347	232	370	974
-	-	-	-	-	-	-	-

Pressure – Temperature Charts

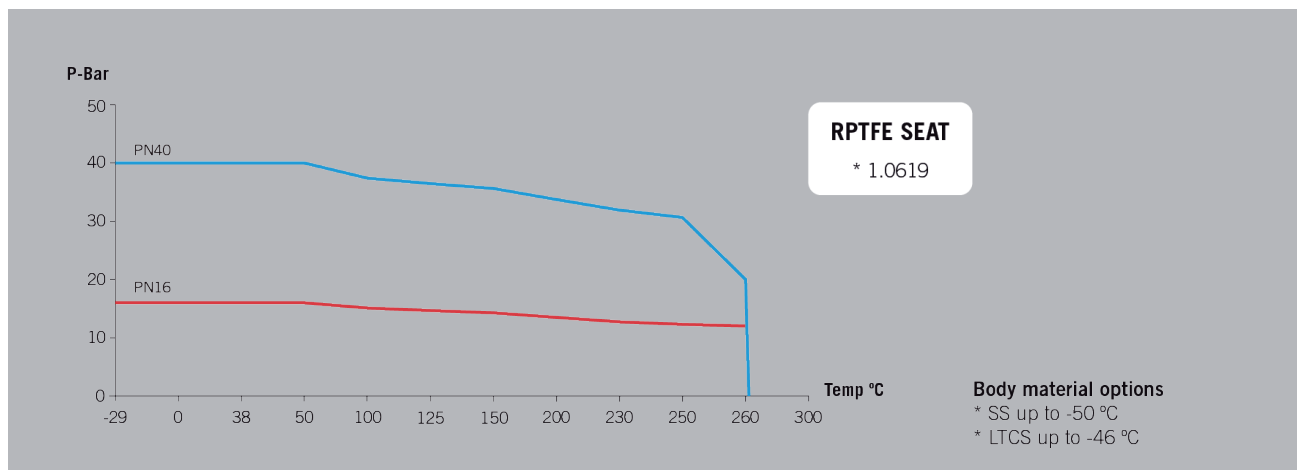
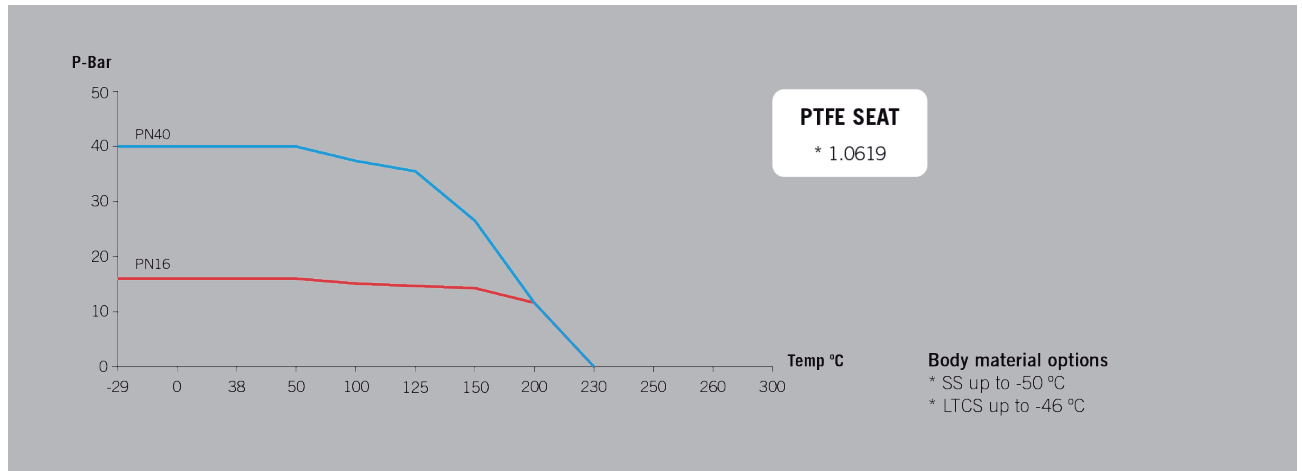

DIN Ball Valves Flowing



Simple Stem Extension



Stem Extension

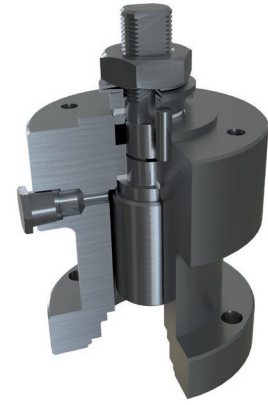

Double Packing Stem Extension



Cavity Relief Seat

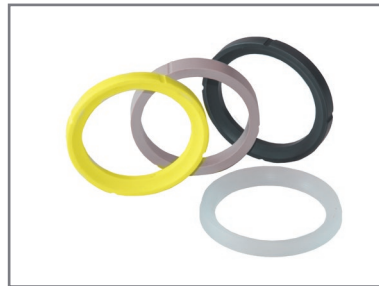

Other Seat materials



Cavity Filler Seat



Stainless Steel Lever

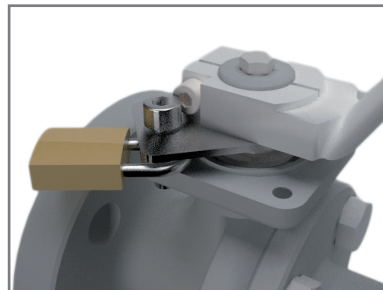

Locking Device



Oval Handwheel
Available from 1/2" to 2"



Manual and Declutchable
Gears



Pneumatic or Hydraulic
Scotch Yoke Actuators



Valve Automation option
available on Request