

ALFA 10N/10NF

PN 10-40/ANSI 150-300

ALFA 10H.P.

PN 63-100/ANSI 600

ALFA 11N/11NF

PN 10-40/ANSI 150-300





CERTIFICATIONS / CERTIFICAZIONI



UNI EN ISO 9001:2015
Cert. Nr. 50 100 6417



Cert. Nr. ADR/RID/ADN-T-AFV
002/004-17-ITA



M.O.C.A. (EC) 1935/2004
(CE) No. 2023/2006



- TA-Luft Certificate
- Fugitive emission ISO 15848-1 & 2



FIRE SAFE API 6FA/API
607 & ISO 10497



TR-CU-10, TR-CU-12 and TR-CU-32
(New GOST) certified for Russian market



ATEX certified by TÜV



CE Marking (Module H1, Category IV)
in accordance with PED 2014/68/EU
certified by TÜV



SIL (Safety integrity level)
certified by TÜV



Canadian Registration Number (CRN)
for Canadian market

LEGAL NOTES / NOTE LEGALI



Supplied temperature and pressure data and other performance information mentioned in this catalogue have been developed from our design calculation and internal test. The data are useful only to cover the standard application as per guidelines for Alfa Valvole products users inside this catalogue.

I dati forniti di pressione-temperatura e altri dati di prestazione pubblicati in questo catalogo sono stati sviluppati da nostri calcoli di progettazione e da test interni. Sono utili solo per coprire le applicazioni tipiche come linee guida generali per gli utenti dei prodotti Alfa Valvole introdotti in questo catalogo.

For every specific application, the users must contact Alfa Valvole for a technical assistance and/or conduct their own study and evaluation to verify the suitability of this products to defined application. Missed observance of this request should involve damages to the ownership and/or personal injury, for which the company cannot be held liable.

Even if this catalogue has been developed with the maximum attention, the company decline all responsibility for errors, impropriety or inadequacy.

Per qualsiasi applicazione specifica, gli utenti sono pregati di contattare Alfa Valvole per un consiglio tecnico e/o di condurre il proprio studio e valutazione per dimostrare l'idoneità di questi prodotti a tale applicazione. La mancata osservanza di questa richiesta potrebbe comportare danni alla proprietà e/o lesioni personali, per i quali l'azienda non potrà essere ritenuta responsabile. Sebbene questo catalogo sia stato redatto con la massima cura e attenzione, l'azienda declina ogni responsabilità per errori, improprietà o inadeguatezza.

All information mentioned in this catalogue about valves characteristics, except for that regulated from international law, may be subject to periodic change without notice.

This edition cancels and replaces all previous documents.

Please carefully read and pay attention to all guidelines for use.

For all information and/or request for further in-depth analysis please contact directly Alfa Valvole.

Private property - in observance of copyright laws in force and related rights, not authorized copying, reproduction and/or advertising, even partially, of this information to third parties without the express written and signed permission of Alfa Valvole is forbidden. All rights reserved.

Qualsiasi informazione fornita in questo catalogo relativamente alle caratteristiche delle valvole, con esclusione di quelle regolamentate da norme internazionali, può essere soggetta a modifiche periodiche senza preavviso.

Questa edizione annulla e sostituisce tutti i numeri precedenti.

Leggere attentamente e prestare attenzione alle indicazioni fornite prima dell'uso.

Per ogni informazione e/o richiesta di approfondimento ulteriori si prega di contattare direttamente Alfa Valvole.

Proprietà riservata - nel rispetto delle norme vigenti in materia di copyright e sul diritto d'autore, la copia, la riproduzione e/o la diffusione, anche parziale di informazioni e/o la comunicazione non autorizzata di dati attraverso qualsiasi mezzo a soggetti terzi, senza l'espressa autorizzazione scritta e firmata da parte di Alfa Valvole del presente documento, è proibita. Tutti i diritti riservati.

STANDARD FEATURES

Caratteristiche standard

- Face to face / Scartamento: **EN 558-1 SERIE 100**
- Design according to / Progettazione secondo: **ASME B16.34, EN 12516-1, PED 2014/68/UE**
- Tightness class / Classe di tenuta: **Grade A (Zero Leakage) acc. EN 12266-1**
- Flange Facing, RF according / Finitura Flange, RF secondo: **EN 1092-1, PN 06-100 / ASME B16.5, ANSI 150-600**
- Flange drilling, metric holes according / Foratura flange, fori metrici secondo: **EN 1092-1, PN 10-100 / ASME B16.5, ANSI 150-600**

STANDARD EXECUTIONS

Esecuzioni standard



CONTAINED BALL INTO THE BODY LENGTH / SFERA CONTENUTA NELLO SCARTAMENTO VALVOLA

No protrusion of the ball over the valve length also in closed position / La sfera anche in posizione di chiusura rimane all'interno dello scartamento valvola

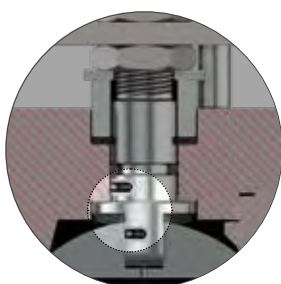

ANTISTATIC DEVICE ACCORDING / DISPOSITIVO ANTISTATICO IN ACCORDO A: API6D - ATEX 2014/34/UE

2 spring loaded balls guarantees electrical continuity between all metallic components of the valve / Garantisce continuità elettrica tra i componenti metallici della valvola grazie a due sfere posizionate sullo stelo



ISO 5211 TOP MOUNTING

Valve top flange is machined for actuator assembly according to ISO 5211 / Foratura premistoppa per montaggio comando secondo normativa ISO 5211

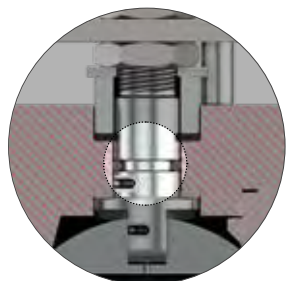

STEM O'RING / O'RING STELO

Maximum tightness from stem packing minimizing Fugitive Emissions (valve certified TA-LUFT e Fugitive Emissions EN 15848-1/-2) / Garantisce la tenuta ottimale dallo stelo minimizzando le emissioni in atmosfera, rendendo le valvole certificate TA-LUFT e Fugitive Emissions EN 15848-1/-2



Before fire



After fire

FIRE SAFE GASKET CONFIGURATION / CONFIGURAZIONE FIRE SAFE

Materials, gaskets and sealing tested and certified according to EN10497, API6FA, API607 standards / Materiali, guarnizioni e tenute testate e certificate secondo norme EN ISO 10497, API 6FA, API 607

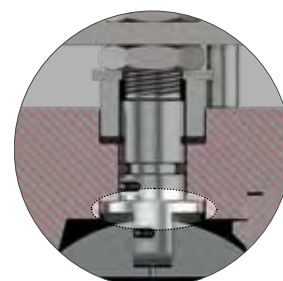

ANTI BLOW-OUT STEM DESIGN / STELO ANTIESPULSIONE

In case of overpressure inside the valve it avoids the stem expulsion and the breakage of the operating element / Evita l'espulsione dello stelo in caso di sovrappressione all'interno della valvola e la rottura dell'elemento di manovra

PRODUCT LINE

Linea prodotti

PRODUCT	CODE	TYPE						SIZE RANGES				RATING								MATERIALS							
		WAFER	3 PIECES	2 PIECES SCREWED BODY	FLANGED	3 WAY WAFER	TRUNNION	NPS 1/4 - 2 (DN 8 -50)	NPS 2 1/4 - 2 (DN 65-100)	NPS 5-8 (DN 125-200)	NPS 10-24 (DN 250-600)	PN 06	ANSI 150 (PN 10-16)	ANSI 300 (PN 25-40)	ANSI 600 (PN 63-100)	ANSI 900	ANSI 1500	ANSI 2500	800/1500 LBS	PN 63 (1000 PSI)	CARBON STEEL	STAINLESS STEEL	OTHER MATERIALS				
A10N - NF	A1N																										
A10 HP	A1H																										
A11N - NF	A1J																										
A10 CALL	A1C/D																										
A10 VAG	A1V																										
A20R / T	A2T/R																										
A22 EV	A2D																										
K20 T	K2T																										
A24K	A24																										
A60P/A64P	A6P																										
A50	A50																										
A54	A54																										
A506	A5S																										
A60	A60																										
A64	A64																										
A68	A68																										
A606	A6S																										
A609/615	A6Q																										
A625	A6V																										
A30	A30																										
A32	A32																										
M34	M34																										
A103	AC3																										
A104	AC4																										
A103/4	ACT																										
T2 FB	AT2																										
T2 RB	AT4																										
T3 FB	AT3																										
T3 RB	AT6																										

MAIN FEATURES

Caratteristiche principali

- **Compact design** / Dimensioni compatte
- **Simple and strong design** / Design semplice ed affidabile
- **Wide range of application, industries and medium** / Versatilità d'uso su differenti fluidi, industrie e applicazioni
- **Size Range** / Range di dimensioni: $\frac{1}{2}'' \leq \varnothing \leq 8''$ / $15 \leq DN \leq 200$
- **Pressure range** / Range di pressioni: **PN 06-100** / **ANSI 150-600**
- **Temperature range** / Temperatura: **-40°C ≤ T ≤ +200°C** (standard execution)
- **Available in different materials (bar stock or casting)** / Disponibilità in diversi materiali, sia da fusione che da barra

CERTIFICATIONS							
PED (DN > 25)	T PED	TA LUFT (fugitive emission)	MOCA	API 6D	FIRE TESTED	SIL	ATEX

INDUSTRY											CODE	PRODUCT
POWER	OIL AND GAS UPSTREAM	REFINING AND PETROCHEMICAL	CHEMICAL	LNG AND CRYOGENIC	MARINE AND NAVY	HVAC	WATER AND WASTEWATER	PHARMACEUTICAL	RAIL AND ROAD TRANSPORTATION	FOOD INDUSTRY		
											A1N	A10N - NF
											A1H	A10 HP
											A1J	A11N - NF
											A1C/D	A10 CALL
											A1V	A10 VAG
											A2T/R	A20R/T
											A2D	A22 EV
											K2T	K20 T
											A24	A24K
											A6P	A60P/A64P
											A50	A50
											A54	A54
											A5S	A506
											A60	A60
											A64	A64
											A68	A68
											A6S	A606
											A6Q	A609/615
											A6V	A625
											A30	A30
											A32	A32
											M34	M34
											AC3	A103
											AC4	A104
											ACT	A103/4
											AT2	T2 FB
											AT4	T2 RB
											AT3	T3 FB
											AT6	T3 RB

ALFA 10N
PN 10-40 | ANSI 150
wafer type ball valve

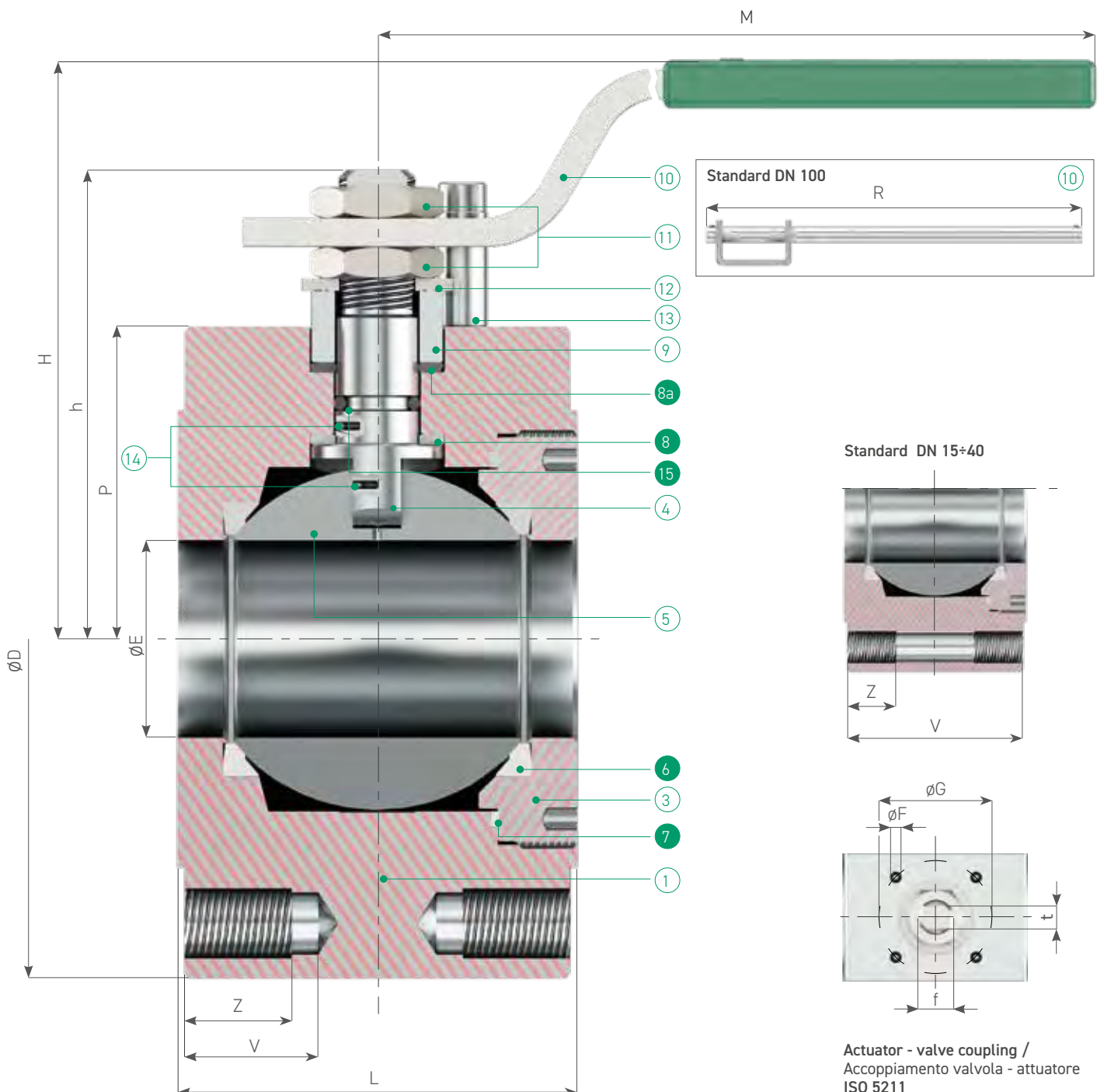

ALFA 10N PN 10-40 | ANSI 150

Standard valve materials / Materiali costruzione valvola standard

Q.TY	PART NAME PARTICOLARE	MATERIALS	
		Q.TA'	MATERIALI
1	body corpo	1	ASTM A105 ASTM A479 316/316L
3	closure chiusura	1	ASTM A105 ASTM A479 316/316L
4	stem stelo	1	ASTM A479 F6a (AISI 410) ASTM A182 316/316L
5	ball sfera	1	ASTM A351 CF8 ASTM A351 CF8M
6	seats sedi	2	TFM
7	body gasket guarnizione corpo	1	P.T.F.E.
8	washer bussola	1	P.T.F.E.
8a	stem gasket guarnizione stelo	2	GRAPHOIL
9	gland premi-guarnizione	1	Carbon steel zinc coated Stainless Steel 316
10	lever leva	1	Carbon steel zinc coated
11	stem nut dado stelo	2	Cl.8 A4-40 (AISI 316)
12	spring washer molla a tazza	2	51 CrV4 Zinc coated AISI 316
13	stop device dispositivo di arresto	1	Cl. 8.8 Zinc Coated AISI 316
14	antistatic device dispositivo antistatico	2	AISI 316
15	stem o-ring o-ring stelo	1	VITON 75 Sh. A

 Spares parts / Parti di ricambio

DIMENSIONS / DIMENSIONI

	DN	15	20	25	32	40	50	50	65	80	100	100	125	150	200
	ø"	½"	¾"	1"	1¼"	1½"	2"	2"	2½"	3"	4"	4"	5"	6"	8"
	ø E	14	19	24	29	38	48	48	64	76	95	95			
	L	36	39	43	51	63	70	83	107	120	140	152			
	M/R	150/-	150/-	185/-	185/-	275/-	275/-	275/-	380/-	380/-	440/500	440/500			
	H	84	87	95	99	118	126	126	143	149	185	185			
	h	52	54	69	72	95	101	101	122	127	151	151			
	P	33	36	43	48	63	68,5	68,5	82	88,5	101,5	101,5			
	f/t	10/6	10/6	12/8	12/8	16/10	16/10	16/10	22/14	22/14	30/18	30/18			
	Kg.	1,6	2	2,6	4,2	6,5	7,8	9,2	17,8	20,5	31	34			
	ISO 5211	F03	F03	F03	F03	F05	F05	F05	F07	F07	F10	F10			
	ø F	M5	M5	M5	M5	M6	M6	M6	M8	M8	M10	M10			
	ø G	36	36	36	36	50	50	50	70	70	102	102			
	V	34*	37*	40*	48*	60*	32	32	33	35	31	31			
	Z	34*	37*	40*	48*	24*	24	24	24	26	21	21			
	ø D	88	98	108	128	138	148	148	178	188	218	218			
VALVOLA PN	N° FORI	4	4	4	4	4	4	4	8	8	8				
	ø FORI	M12	M12	M12	M16	M16	M16	M16	M16	M16	M16				
VALVOLA ANSI	N° FORI	4	4	4	4	4	4	4	4	8	8				
	ø FORO METR.	M14	M14	M14	M14	M14	M16	M16	M16	M16	M16				
	ø FORO UNC	½"	½"	½"	½"	½"	¾"	¾"	¾"	¾"	¾"				

SEE / VEDERE
ALFA 10NF

● On request / A richiesta

* Full threaded holes / Fori passanti filettati



ALFA 10NF
PN 10-40 | ANSI 150
wafer type ball valve

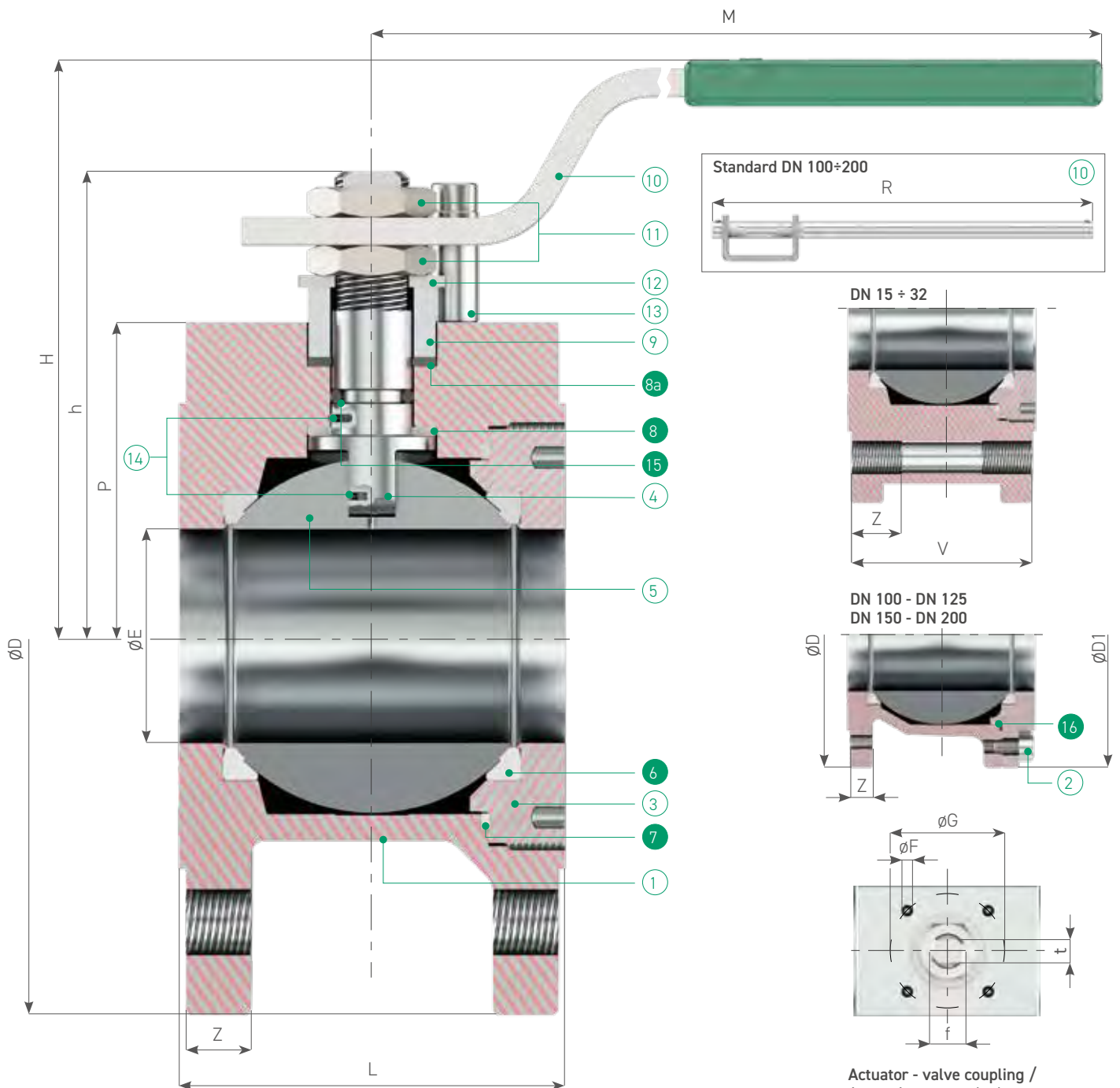
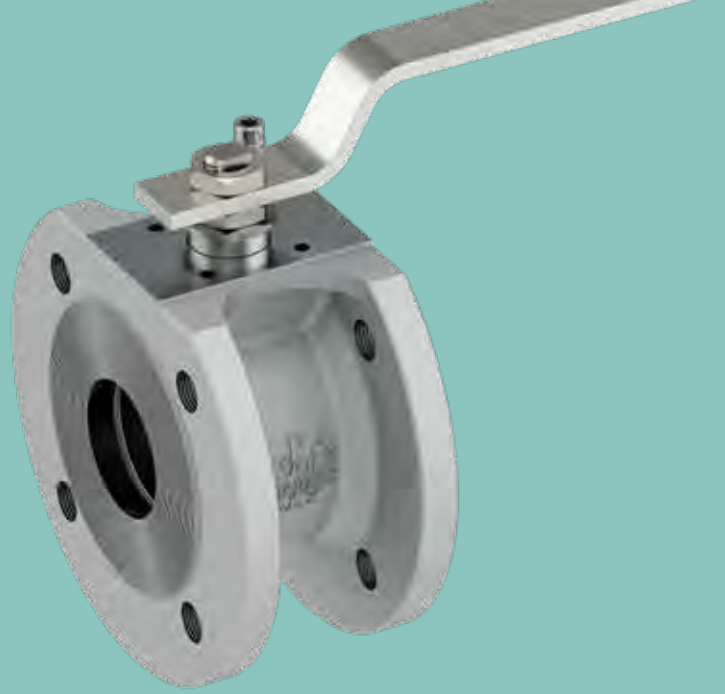

ALFA 10NF PN 10-40 | ANSI 150

Standard valve materials / Materiali costruzione valvola standard

	 PART NAME PARTICOLARE	Q.TY Q.TA'	MATERIALS MATERIALI		
1	body corpo	1	ASTM A216 WCB	ASTM A351 CF8M	ASTM A351 CF8
2	screw vite	8/12	C.I.8.8	A4-40 (AISI 316)	
3	closure chiusura	1	ASTM A216 WCB	ASTM A351 CF8M	ASTM A351 CF8
4	stem stelo	1	ASTM A479 F6a (AISI 410)	ASTM A182 316/316L	
5	ball sfera	1	ASTM A351 CF8	ASTM A351 CF8M	ASTM A351 CF8
6	 seats sedi	2	TFM		
7	 body gasket guarnizione corpo	1	P.T.F.E./GRAPHOIL (DN≥100)	P.T.F.E./GRAPHOIL (DN≥100)	
8	 washer bussola	1	P.T.F.E.		
8a	 stem gasket guarnizione stelo	2	GRAPHOIL		
9	gland premi-guarnizione	1	Carbon Steel Zinc Coated	Stainless Steel 316	
10	lever leva	1	Carbon Steel Zinc Coated		
11	stem nut dado stelo	2	Cl. 8	A4-40 (AISI 316)	
12	spring washer molla a tazza	2	51CrV4 Zinc Coated	AISI 316	
13	stop device dispositivo di arresto	1	Cl. 8.8 Zinc Coated	AISI 316	
14	antistatic device dispositivo antistatico	2	AISI 316		
15	 stem o-ring o-ring stelo	1	VITON 75 Sh. A		
16	 body o-ring (DN ≥100) o-ring corpo	1	P.T.F.E.		

 Spares parts / Parti di ricambio

DIMENSIONS / DIMENSIONI

	DN	15	20	25	32	40	50	65	80	100	125	150	200
	ø"	½"	¾"	1"	1¼"	1½"	2"	2½"	3"	4"	5"	6"	8"
ø E		14	19	24	29	38	48	64	76	95	118	152	203
L PN10/16											180	243	314
L ANSI 150		36	39	43	51	63	83	107	120	152			
L PN 25/40											210	255	314
M/R		150/-	150/-	185/-	185/-	275/-	275/-	380/-	380/-	440/500	440/500	-/800	-/800
H		84	87	95	99	118	126	143	149	185	200	273	322
h		52	54	69	72	95	101	122	127	151	167	220	270
P		33	36	43	48	63	68,5	82	88,5	101,5	122	153	200
f/t		10/6	10/6	12/8	12/8	16/10	16/10	22/14	22/14	30/18	30/18	45/30	52/30
Kg.		1.2	1,6	2,2	3	4,8	6,6	11	13,6	24,2	35,6	74	132
ISO 5211		F03	F03	F03	F03	F05	F05	F07	F07	F10	F10	F14	F14
ø F		M5	M5	M5	M5	M6	M6	M8	M8	M10	M10	M16	M16
ø G		36	36	36	36	50	50	70	70	102	102	140	140
V		34*	37*	40*	48*	-	-	-	-	-	-	-	-
Z		34*	37*	40*	48*	13	14	15,5	15	18	22	23,5	26
ø D/ø D1		90	100	105	125	148	165	185	200	218/218	252/252	284/305	340/380
VALVOLA PN	N° FORI	4	4	4	4	4	4	4	8	8	8	8	12
	ø FORI	M12	M12	M12	M16	M16	M16	M16	M16	M16	M16	M20	M20
VALVOLA ANSI	N° FORI	4	4	4	4	4	4	4	4	8	8	8	8
	ø FORO METR.	M14	M14	M14	M14	M14	M16	M16	M16	M16	M20	M20	M20
	ø FORO UNC	½"	½"	½"	½"	½"	¾"	¾"	¾"	¾"	¾"	¾"	¾"

* Full threaded holes / Fori passanti filettati

Alnab Armatur AB
Ögårdesvägen 4B
SE-433 30 Partille

www.alnab.se
alnab@alnab.se
Tel +46 31 449450



ASSEMBLY CONFIGURATIONS

Varianti di montaggio

SCREW MOUNTING / MONTAGGIO VITI

Removing one of 2 pipes, valve remains installed and in operation.

Smontando una delle tubazioni, la valvola rimane installata e funzionante.

APPLICABLE TO / APPLICABILE A:
 ALFA 10N PN 10-40 | ANSI 150 / 300
 ALFA 10NF PN 10-40 | ANSI 150
 ALFA 10H.P. PN 63-100 | ANSI 600

STANDARD FOR ALL VALVES / STANDARD PER TUTTE LE VALVOLE

HEX BOLTS / VITI TE

FLANGES / FLANGE

THREADED HOLES /
FORI FILETTATI

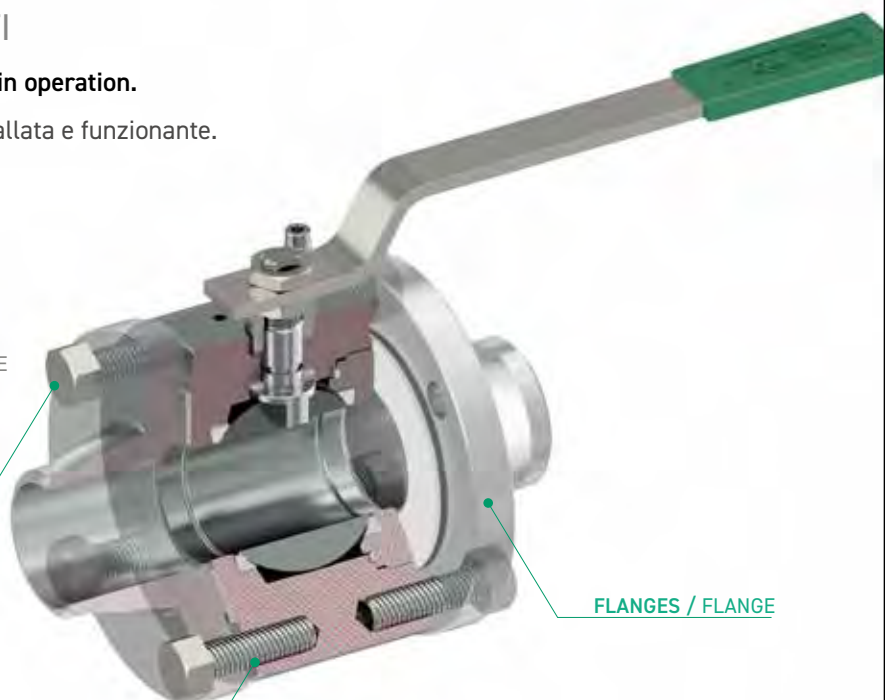

BOTTOM TANK ASSEMBLY / MONTAGGIO FONDO SERBATOIO

Stay bolt machining / Lavorazione per montaggio prigionieri

Removing the pipe on downstream side, valve remains installed and in operation.

Smontando la tubazione a valle, la valvola rimane installata e funzionante.

APPLICABLE TO / APPLICABILE A:
 ALFA 10N PN 10-40 | ANSI 150
 ALFA 10NF PN 10-40 | ANSI 150

APPLICABLE VALVES / VALVOLE APPLICABILI

DN	PN 16 / ANSI 150		ANSI 300	
	A1NF	A1N	A1NF	A1N
15				
20				
25				
32				
40				
50				
65				
80				*
100		*		

SPECIAL MACHINED HOLES /
FORI PER MONTAGGIO PRIGIONIERI

STAY BOLTS / PRIGIONIERI

NUTS / DADI

VESSEL / SERBATOIO

VALVE / VALVOLA

FLANGE / FLANGIA

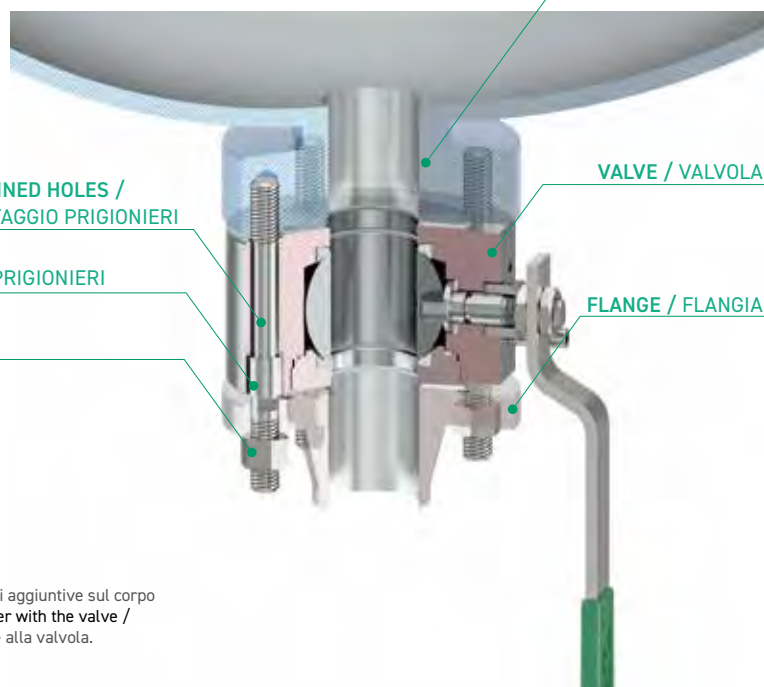

* Drilling needs additional machining on the body / La foratura comporta lavorazioni aggiuntive sul corpo
 Valve machining for long bolt mounting requires supply of special long bolts together with the valve /
 La lavorazione per prigionieri richiede l'utilizzo di prigionieri speciali, forniti insieme alla valvola.

STUD BOLT MOUNTING / MONTAGGIO TIRANTI

Removing one of 2 pipes, valve DOESN'T remains installed.

Smontando una delle tubazioni, la valvola NON rimane installata.

APPLICABLE TO / APPLICABILE A:
ALFA 10N PN 10-40 | ANSI 150

APPLICABLE VALVES / VALVOLE APPLICABILI

DN	PN 16		ANSI 150	
	A1NF	A1N	A1NF	A1N
15				
20				
25				
32				
40				
50				
65				
80	**			
100		*		*

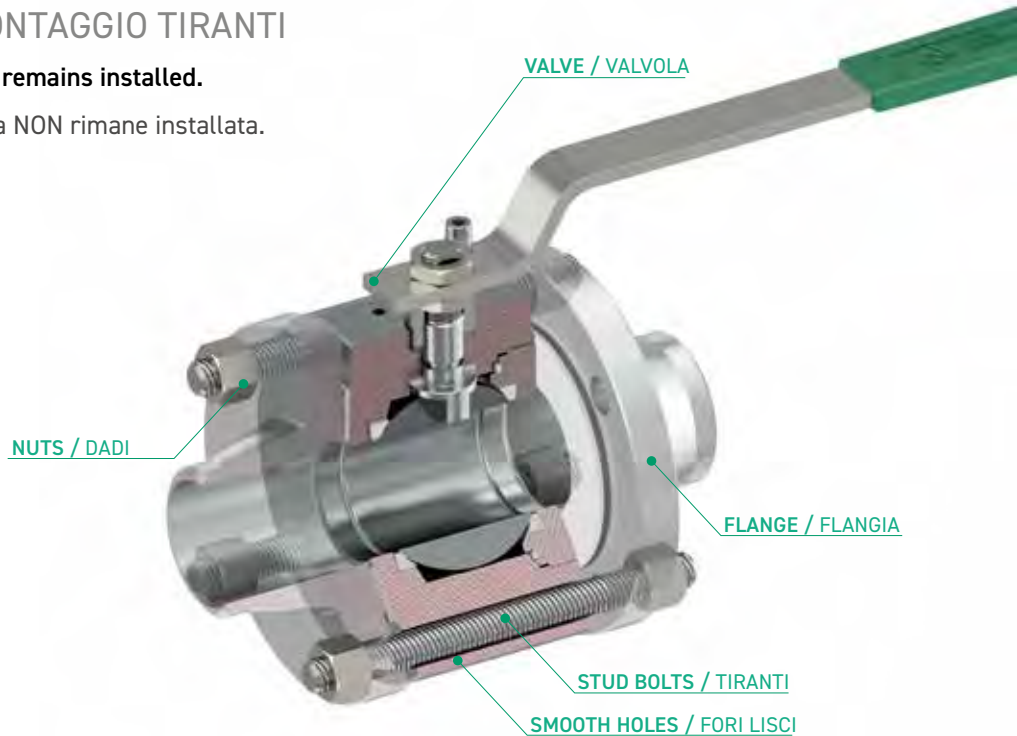

* Drilling needs the welding of one flange on ISO plan / La foratura comporta la saldatura di una flangia sul piano ISO
 ** Drilling cause the removal of 2 holes from ISO plan (the valve cannot be motorized anymore but is only supplied with lever) /
 La foratura comporta l'eliminazione di 2 fori dal piano ISO (la valvola non è più motorizzabile ma solo fornibile a leva)

BOTTOM TANK ASSEMBLY / MONTAGGIO FONDO SERBATOIO

Body smooth holes machining / Lavorazione fori lisci lato corpo

Removing the pipe on downstream side, valve remains installed and in operation.

Smontando una delle tubazioni, la valvola rimane installata e funzionante.

APPLICABLE TO / APPLICABILE A:
ALFA 10NF PN 10-40 | ANSI 150

APPLICABLE VALVES / VALVOLE APPLICABILI

DN	PN 16		ANSI 150	
	A1NF	A1N	A1NF	A1N
15				
20				
25				
32				
40	*		*	
50				
65				
80	**			
100	**		**	
125				
150				
200	*		*	

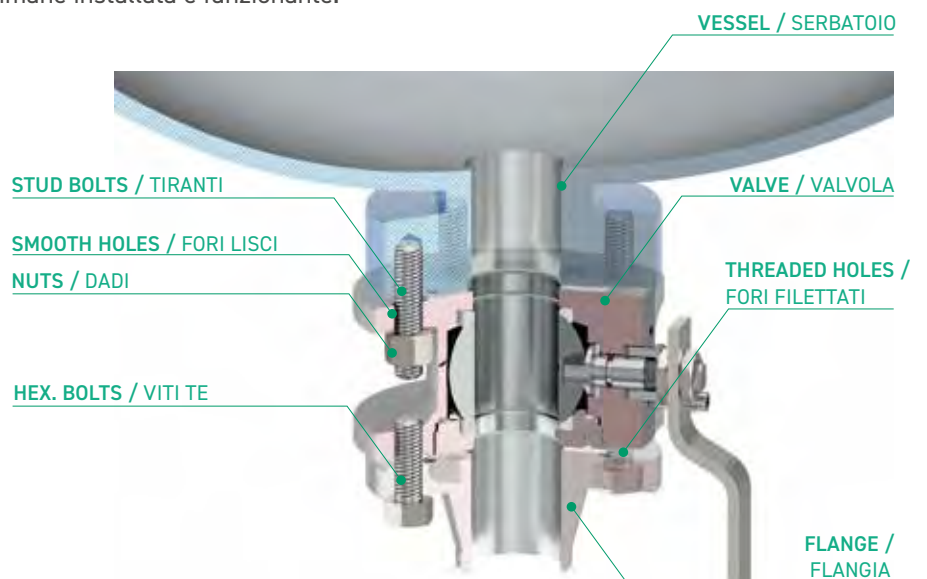





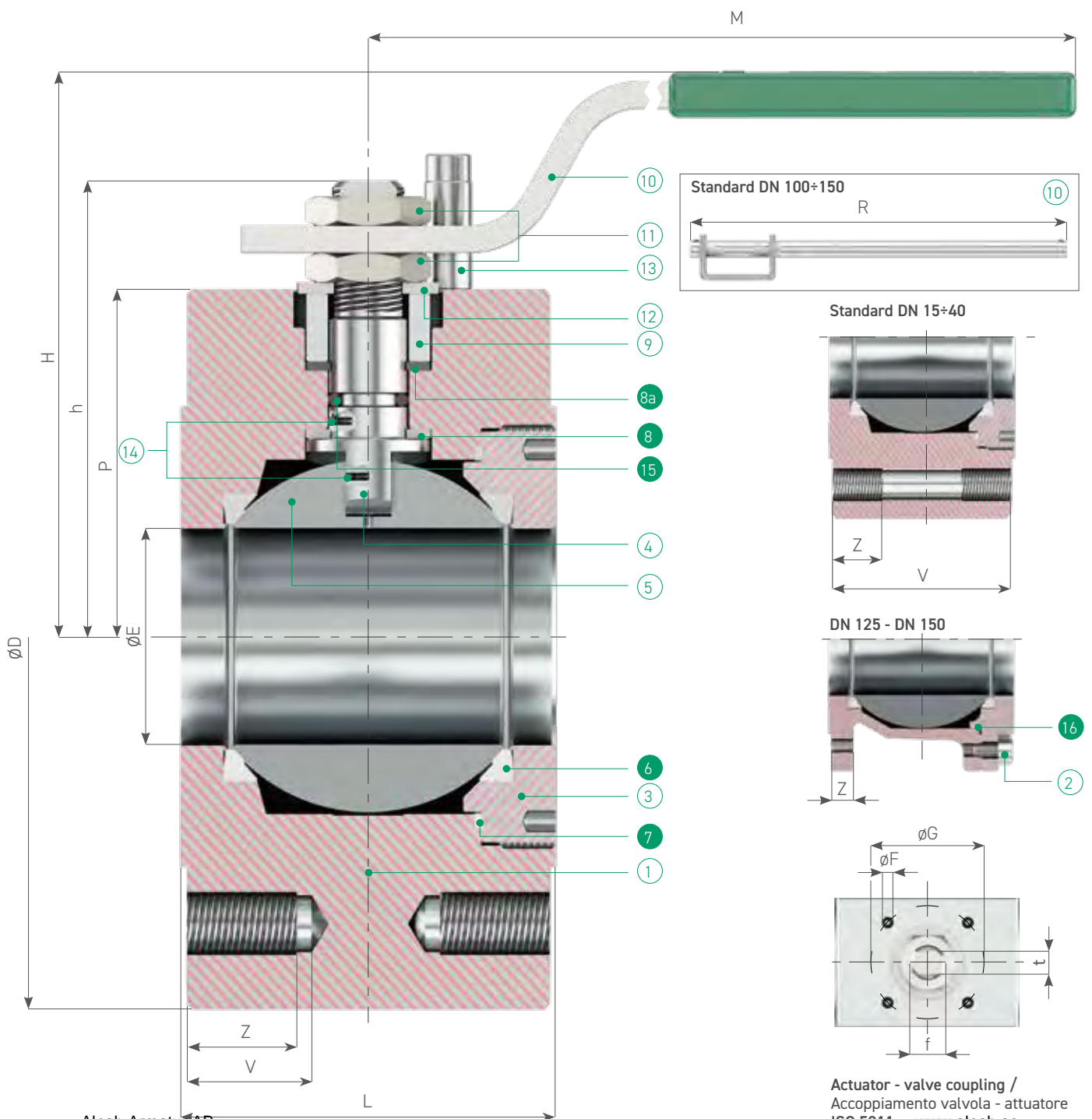

* Drilling needs additional machining on the body / La foratura comporta lavorazioni aggiuntive sul corpo
 ** Drilling cause the removal of 2 holes from ISO plan (the valve cannot be motorized anymore but is only supplied with lever) /
 La foratura comporta l'eliminazione di 2 fori dal piano ISO (la valvola non è più motorizzabile ma solo fornibile a leva)

**ALFA 10N/10NF
ANSI 300**
wafer type ball valve



ALFA 10N/10NF ANSI 300

Standard valve materials / Materiali costruzione valvola standard

	 PART NAME PARTICOLARE	Q.TY Q.TA'	MATERIALS MATERIALI	
1	body corpo	1	ASTM A105 *	ASTM A479 316/316L **
2	screw vite	8	Cl. 8.8 Zinc.	A4-70 (AISI 316)
3	closure chiusura	1	ASTM A105 *	ASTM A479 316/316L **
4	stem stelo	1	ASTM A479 F6a (AISI 410)	ASTM A182 316/316L
5	ball sfera	1	ASTM A351 CF8	ASTM A351 CF8M
6	 seats sedi	2	TFM	
7	 body gasket guarnizione corpo	1	P.T.F.E./GRAPHOIL (DN ≥ 100)	
8	 washer bussola	1	P.T.F.E.	
8a	 stem gasket guarnizione stelo	2	GRAPHOIL	
9	gland premi-guarnizione	1	Carbon steel Zinc Coated	Stainless Steel 316
10	lever leva	1	Carbon steel Zinc Coated	
11	stem nut dado stelo	2	Cl.8	A4-40 (AISI 316)
12	spring washer molla a tazza	2	51CrV4 Zinc Coated	AISI 316
13	stop device dispositivo di arresto	1	Cl. 8.8 Zinc Coated	AISI 316
14	antistatic device dispositivo antistatico	2	AISI 316	
15	 stem o-ring o-ring stelo	1	VITON 75 Sh. A	
16	 body o-ring (DN ≥ 100) o-ring corpo	1	P.T.F.E.	

* DN ≥ 125: ASTM A216 WCB

** DN ≥ 125: ASTM A351 CF8M

 Spares parts / Parti di ricambio

DIMENSIONS / DIMENSIONI

ALFA 10N

DN	15	20	25	32	40	50	65	80	100
ø"	½"	¾"	1"	1¼"	1½"	2"	2½"	3"	4"
ø E	14	19	24	29	38	48	64	76	95
L	36	39	43	51	63	83	107	120	152
M/R	150/-	150/-	185/-	185/-	275/-	275/-	380/-	380/-	440/500
H	84	87	95	99	118	126	143	149	185
h	52	54	69	72	95	101	122	127	151
P	33	36	43	48	63	77	86	90	113
f/t	10/6	10/6	12/8	12/8	16/10	16/10	22/14	22/14	30/18
Kg.	1.7	2.3	3	4	7	11.8	17	26	46
ISO 5211	F03	F03	F03	F03	F05	F05	F07	F07	F10
ø F	M5	M5	M5	M5	M6	M6	M8	M8	M10
ø G	36	36	36	36	50	50	70	70	102
V	34*	37*	40*	60*	48*	32	38	35	40
Z	34*	37*	40*	60*	48*	24	28	26	30
ø D	96	118	124	133	156	165	189	209	254
N° FORI	4	4	4	4	4	8	8	8	8
ø FORO METR.	M14	M16	M16	M16	M20	M16	M20	M20	M20
ø FORO UNC	½"	⅝"	⅝"	⅝"	¾"	⅝"	¾"	¾"	¾"

ALFA 10NF

125	150
5"	6"
118	152
210	255
440/500	-/800
200	273
167	220
122	153
30/18	45/30
40	69
F10	F14
M10	M16
102	140
-	-
33	35
280	317,5
8	12
M20	M20
¾"	¾"

* Full threaded holes / Fori passanti filettati



ALFA 10HP
PN 63-100 | ANSI 600
wafer type ball valve

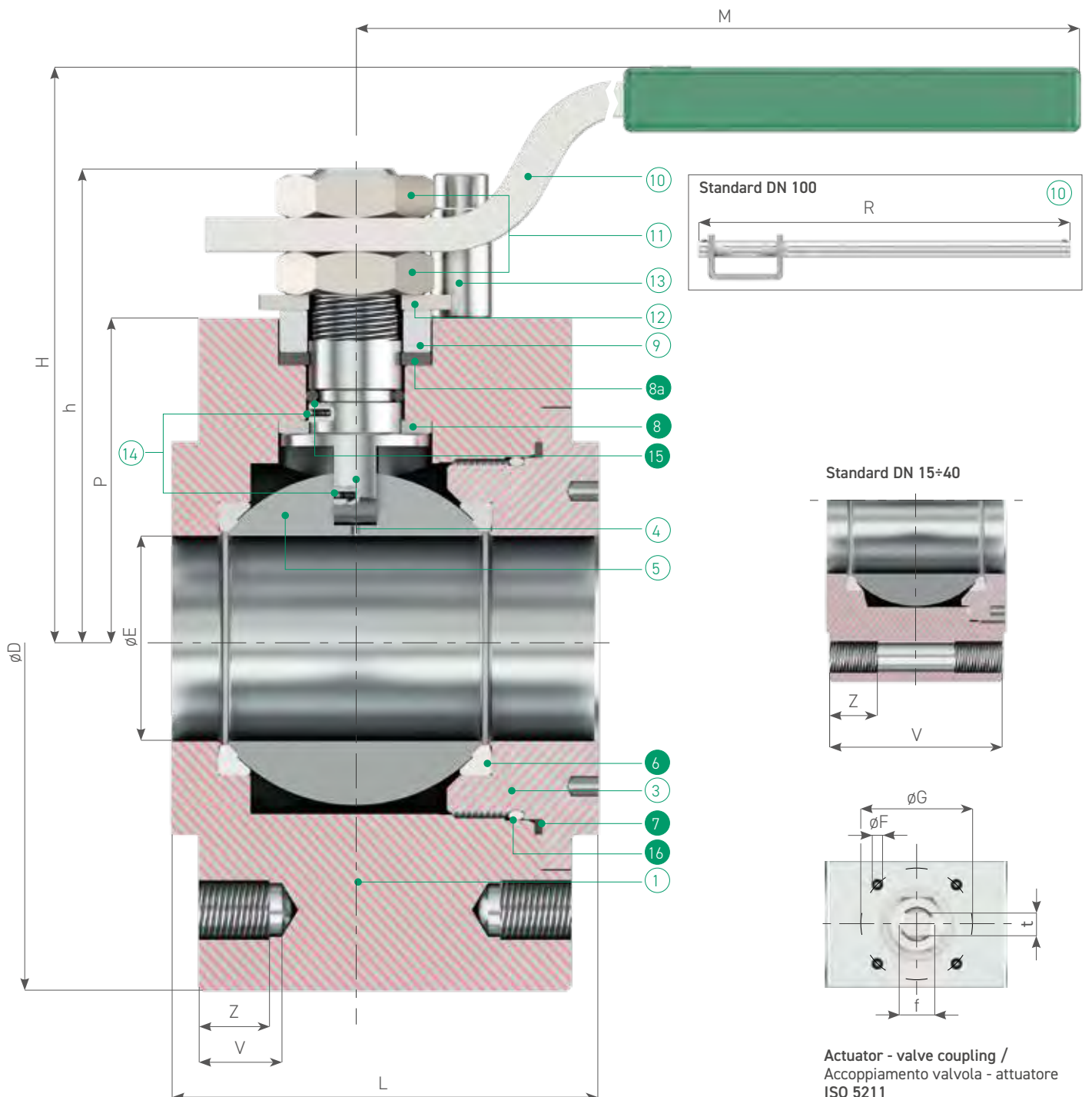
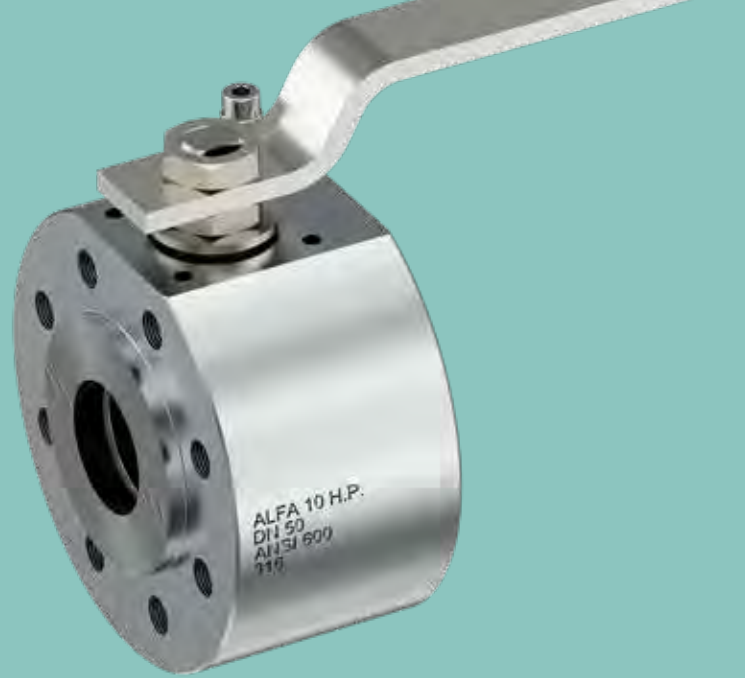

ALFA 10HP PN 63-100 | ANSI 600

Standard valve materials / Materiali costruzione valvola standard

	PART NAME PARTICOLARE	Q.TY Q.TA'	MATERIALS MATERIALI	
1	body corpo	1	ASTM A105	ASTM A479 316/316L
3	closure chiusura	1	ASTM A105	ASTM A479 316/316L
4	stem stelo	1	ASTM A182 F51	
5	ball sfera	1	ASTM A351 CF8	ASTM A351 CF8M
6	seats sedi	2	TFM / P.T.F.E. + A.M. (DN > 40)	
7	body gasket guarnizione corpo	1	P.T.F.E. / GRAPHOIL (DN > 50)	
8	washer bussola	1	P.T.F.E.	
8a	stem gasket guarnizione stelo	2	GRAPHOIL	
9	gland premi-guarnizione	1	Carbon Steel Zinc Coated	Stainless Steel 316
10	lever leva	1	Carbon Steel Zinc Coated	
11	stem nut dado stelo	2	Cl. 8	A4-40 (AISI 316)
12	spring washer molla a tazza	2	51CrV4 Zinc Coated	AISI 316
13	stop device dispositivo di arresto	1	Cl. 8.8 Zinc Coated	AISI 316
14	antistatic device dispositivo antistatico	2	AISI 316	
15	stem o-ring o-ring stelo	1	VITON 90 Sh. A AED	
16	body o-ring (DN>50) o-ring corpo	1	VITON 90 Sh. A AED	

 Spares parts / Parti di ricambio

DIMENSIONS / DIMENSIONI

	DN	15	20	25	32	40	50	65	80	100
	ø"	½"	¾"	1"	1¼"	1½"	2"	2½"	3"	4"
ø E	14	19	24	29	38	48	64	76	95	
L	55	60	65	75	85	100	125	150	185	
M/R	150/-	150/-	275/-	275/-	380/-	380/-	440/500	440/500	-/800	
H	84	87	102	105	125	134	169	174	231	
h	52	54	75	78	104	110	136	141	175	
P PN63							93	97.5	107	
P PN100	33	36	51	53	65	75	95.5	105	115	
P ANSI600							85.5	95	121.5	
f/t	10/6	10/6	16/10	16/10	22/14	22/14	30/18	30/18	45/30	
Kg.	2.5	5	6	9	10	14	31	40	67	
ISO 5211	F03	F03	F05	F05	F07	F07	F10	F10	F14	
ø F	M5	M5	M6	M6	M8	M8	M10	M10	M16	
ø G	36	36	50	50	70	70	102	102	140	
V	43*	47*	52*	62*	72*	30	36	40	45	
Z	43*	47*	52*	62*	72*	24	28	30	35	
ø D (ANSI)	96	118	124	133	156	165	191	209	273	
ø D (PN63)	105	129	139	155	169	179	205	215	249	
ø D (PN100)	105	129	139	155	169	195	219	229	265	
VALVOLA PN	N° FORI	4	4	4	4	4	8	8	8	
	ø FORI	M14	M16	M26	M20	M20	M24	M24	M24	M27
VALVOLA ANSI	N° FORI	4	4	4	4	4	8	8	8	
	ø FORO METR.	M14	M16	M16	M16	M20	M16	M20	M20	M24
	ø FORO UNC	½"	¾"	¾"	¾"	¾"	¾"	¾"	¾"	¾"

* Full threaded holes / Fori passanti filettati
Alnab Armatur AB
Ögärdesvägen 4B
SE-433 30 Partille

www.alnab.se
alnab@alnab.se
Tel +46 31 449450



ALFA 11N/11NF

PN 10-40 | ANSI 150-300

wafer type ball valve

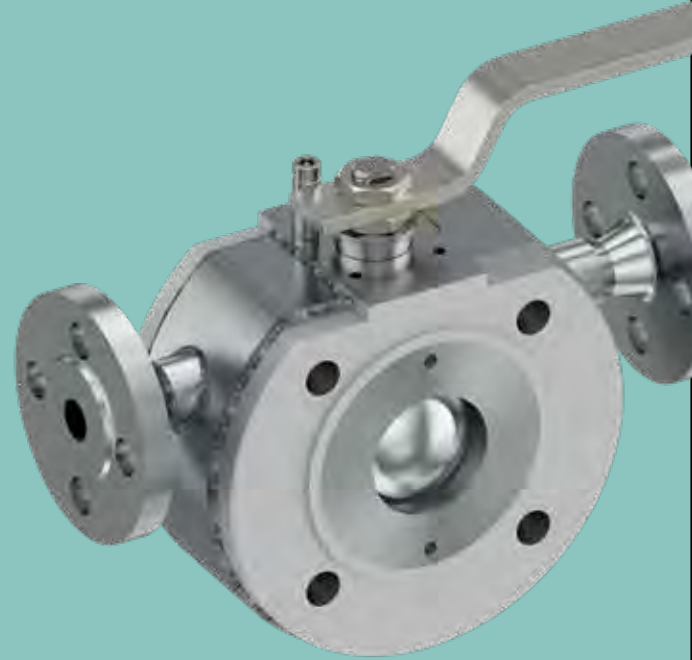

MAIN FEATURES / CARATTERISTICHE

- **Heating/cooling jacket integral to the valve body, applicable on bar stock valve (A10N) and on casting body valve (A10NF) /**
Camicia di riscaldamento/raffreddamento integrale, fornibile sia con valvola da barra (A10N) che valvola da fusione (A10NF).
- **For application requiring a fixed fluid temperature inside the valve body, through circulation inside the jacket of hot water, steam, diathermic oil or other fluid /** Per applicazioni che necessitano il mantenimento di una temperatura del fluido di processo all'interno della valvola costante, mediante circolazione all'interno della camicia di acqua calda, vapore, olio diatermico o altro fluido.
- **Metal thickness /** Spessore lamiera: **3 mm**
- **Jacket hollow space /** Intercapedine camera: **10 mm**
- **Maximum operating jacket pressure /** Pressione massima di funzionamento camicia: **16 bar**
- **Jacket material /** Materiale camicia:
Carbon steel type S235 JR (Carbon steel body valves) / Acciaio al carbonio S235 JR (Valvole acciaio al carbonio)
Pickled stainless steel AISI 316 (Stainless steel body valves) / Acciaio inossidabile AISI 316 decappato (Valvole acciaio inox)
- **100% hydraulic tested - welding process ASME qualified /** Test idraulico al 100% - processo di saldatura qualificato ASME.
- **For valve technical features, please refers to standard valve family /** Per le caratteristiche costruttive delle valvole fare riferimento alle famiglie base.
- **For different configuration type, number and position of jacket connection please contact our engineering dept /** Per varianti su tipo, numero e posizione attacchi contattare l'ufficio tecnico.

DIMENSIONS / DIMENSIONI

DN	15	20	25	32	40	50	65	80	100	125	150	200
ø"	½"	¾"	1"	1¼"	1½"	2"	2½"	3"	4"	5"	6"	8"
A	180	180	190	210	230	250	270	300	340	380	420	500
B	-	-	-	25	30	30	45	50	70	80	95	130
ø D	114	124	131	151	174	191	211	226	244	278	310/331	366/406
ø m	½" GAS								1" GAS			
ø F	DN 15						DN 25					
Kg. Threaded/ Filettate	2,7	3,1	3,7	4,5	6,8	8,6	14	16,6	28,2	41,6	82	142
Kg. Flanged/ Flangiate	4,7	5,1	5,7	6,5	8,8	10,6	16	18,6	32,2	45,6	86	146

For construction and dimensions see ALFA 10N/10NF / Per costruzione e dimensioni vedere ALFA 10N/10NF
Weight for casting body valves / Peso per valvole ricavate da fusione

FLANGED CONNECTION / ATTACCO FLANGIATO
(EN1092-1 PN16, ANSI 150)

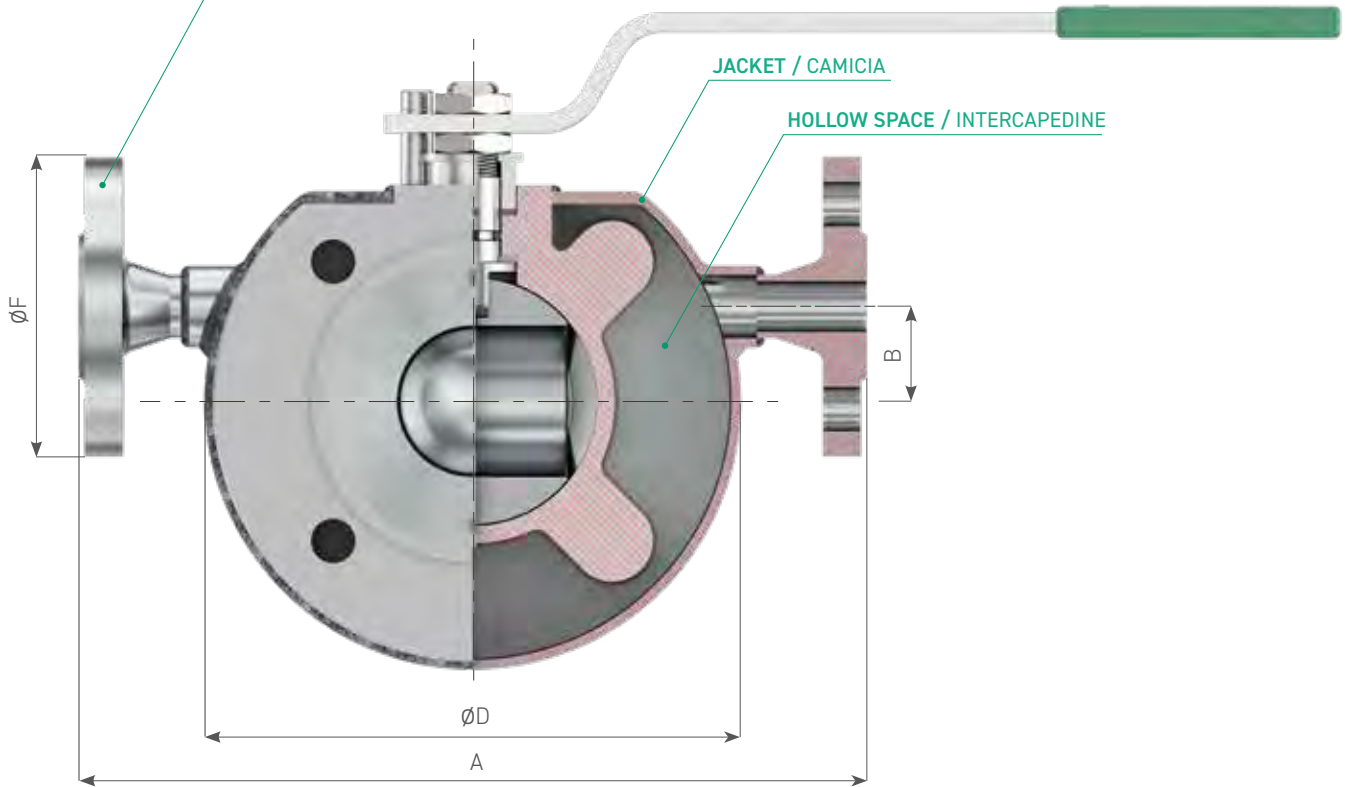

THREADED CONNECTION / ATTACCO FILETTATO
(GAS-F ANSI B1.20.1)

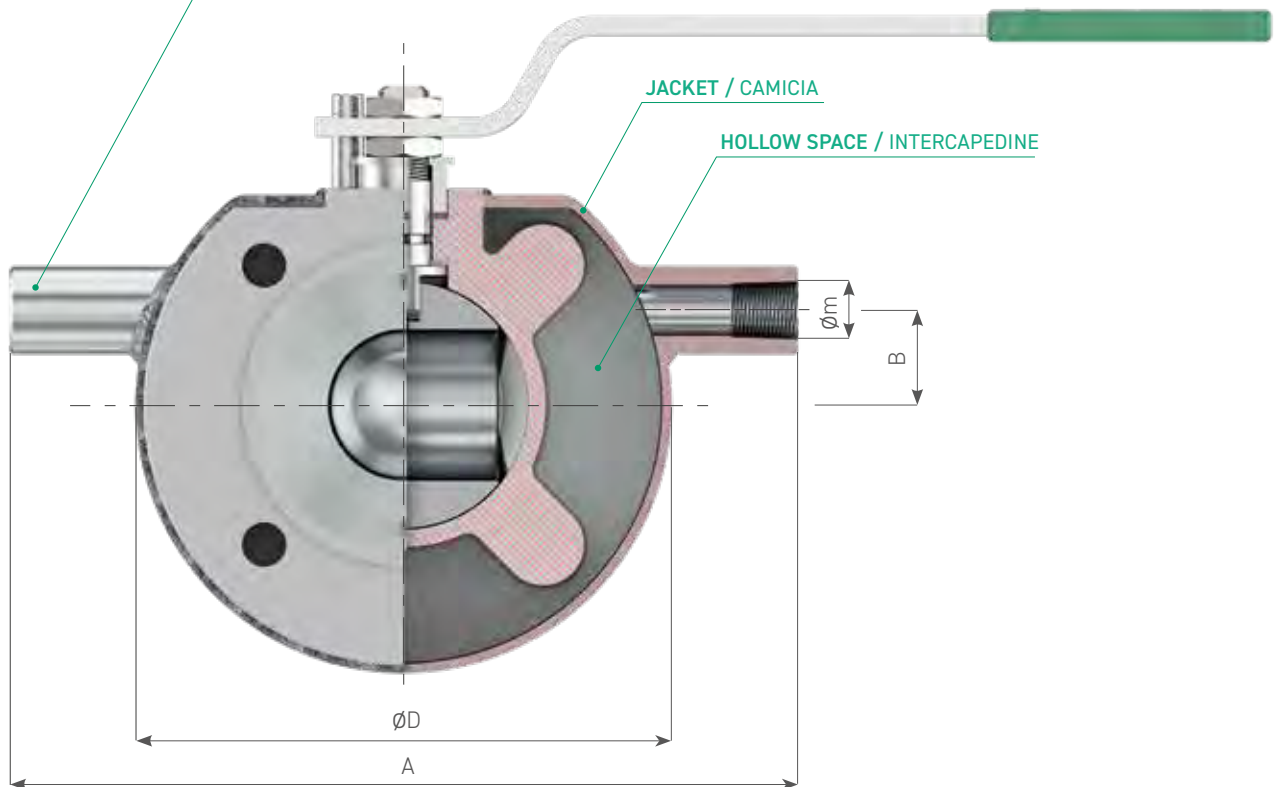

(P,T) DIAGRAMS

Diagrammi (P,T)

ALFA 10N/10NF - 10HP - 11N/11NF

Pressure - temperature diagrams shown the standard working conditions (pressure & temperature) for the specific valve. These conditions refer to a continuous use. For transitions for peak condition, an overload until 10% is accepted. In these cases we suggest anyway to contact engineering dept.

I diagrammi pressione - temperatura identificano le condizioni di uso contemporanee di pressione e temperatura a cui la valvola può operare. Tali condizioni sono da riferirsi ad un uso continuo. Per condizioni transitorie o di picco, scostamenti fino al 10% sono tollerati. In tali casistiche consultare comunque l'ufficio tecnico di Alfa Valvole.

TFM SEATS / SEDI IN TFM



MAIN FEATURES / CARATTERISTICHE

- **PTFE reinforced at molecular stage** / PTFE rinforzato a livello molecolare
- **Chemical optimized structure guarantees a constant response in continuous service until 200°C** / La struttura chimica ottimizzata garantisce performance stabili in servizio continuo fino a 200°C
- **Lubricating properties, dimensional stability and chemical compatibility equal to virgin PTFE** / Potere lubrificante, stabilità dimensionale e compatibilità chimica del PTFE
- **Mechanical and wear resistance equal to reinforced PTFE** / Resistenza meccanica e all'usura equivalente al PTFE rinforzato

ALFAGRAPH SEATS / SEDI IN ALFAGRAPH



MAIN FEATURES / CARATTERISTICHE

- **Company owned compound: PTFE + CARBON + GLASS + GRAPHITE** / Miscela proprietaria: PTFE + CARBONE + VETRO + GRAFITE
- **Increased pressure resistance at high temperature thanks to the carbon filling** / Incremento della resistenza alla pressione alle alte temperature grazie all'aggiunta di carbone
- **Less deformation under load thanks to the glass filling** / Minore deformazione sotto carico grazie all'aggiunta di vetro
- **Better operating torque control thanks to lubricating power of graphite filling** / Coppie sotto controllo grazie al potere lubrificante della grafite

PTFE SEATS + METAL CORE / SEDI IN PTFE + AM



MAIN FEATURES / CARATTERISTICHE

- **PTFE enclosure with metal core in AISI 316** / Ptfè con inserto metallico in AISI 316
- **Better performances at temperature until 210° C thanks to metal core** / Il nucleo metallico garantisce ottime performance a temperature fino a 210° C e ad alte pressioni
- **Chemical compatibility thanks to PTFE enclosure** / La capsula in PTFE garantisce compatibilità chimica
- **Increased dimensional stability thanks to an optimized production process** / Incrementata stabilità dimensionale grazie al processo di produzione della sede

PEEK SEATS / SEDI IN PEEK



MAIN FEATURES / CARATTERISTICHE

- **Semi-Crystalline polymer with unique combination of mechanical and thermal properties** / Polimero semi-cristallino con proprietà meccaniche e termiche uniche
- **Withstand temperature until 250°C and pressure until 420 Bar** / Resiste a temperature fino 250°C e pressioni di 420 bar
- **Excellent chemical compatibility (Only known solvent: sulfuric acid)** / Eccellente compatibilità chimica (Unico solvente noto: acido solforico concentrato)

Notes / Eccezioni

To obtain maximum temperature performances (> 210°C), also valve O-Ring replacement is needed / Per ottenere le massime performance di temperatura (> 210°C) è necessario sostituire gli O-Ring valvola

Using PEEK seats increase torque about of 100% / Il montaggio di sedi in peek aumenta le coppie della valvola di circa il 100%

High temperature performances cannot guarantee class VI tightness at room temperature / La performance ad alte temperature non garantisce la tenuta in classe VI della valvola a temperatura ambiente

Peek seated valve could not be fire safe certified (please contact your Alfa Valvole reference) / La valvola con sedi in peek potrebbe non essere certificata fire safe. (Contattare il vostro referente Alfa Valvole)





VALVES / VALVOLE: ALFA 10N/10NF - 11N/11NF TFM SEATS /SEDI IN TFM (STANDARD EXECUTION)

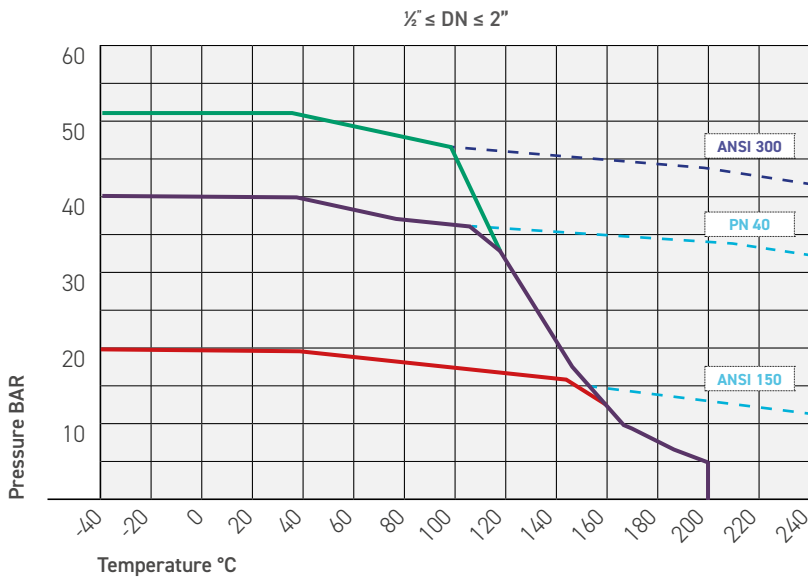

DN	$\frac{1}{2}'' \leq DN \leq 2''$ (15 ≤ DN ≤ 50)
P max @ Tmax	6,5 bar @ 200°C

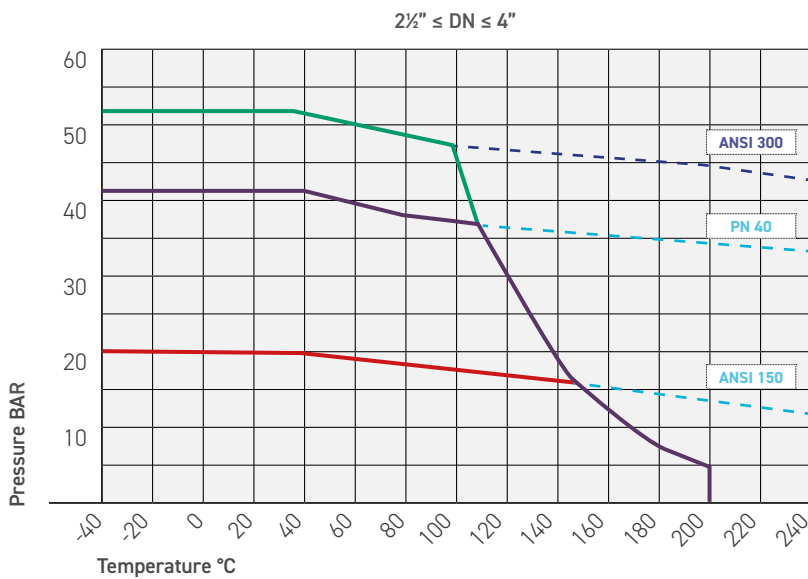

DN	$2\frac{1}{2}'' \leq DN \leq 4''$ (65 ≤ DN ≤ 100)
P max @ Tmax	5,5 bar @ 200°C

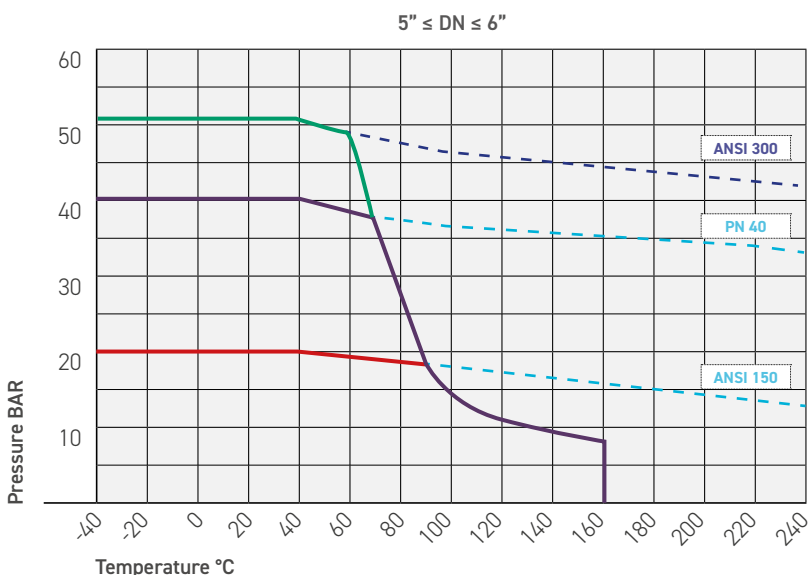

DN	$5'' \leq DN \leq 6''$ (125 ≤ DN ≤ 150)
P max @ Tmax	8 bar @ 160°C



VALVES / VALVOLE: ALFA 10N/10NF - 11N/11NF

ALFAGRAPH SEATS / SEDI IN ALFAGRAPH (ON REQUEST)

$\frac{1}{2}'' \leq DN \leq 2''$

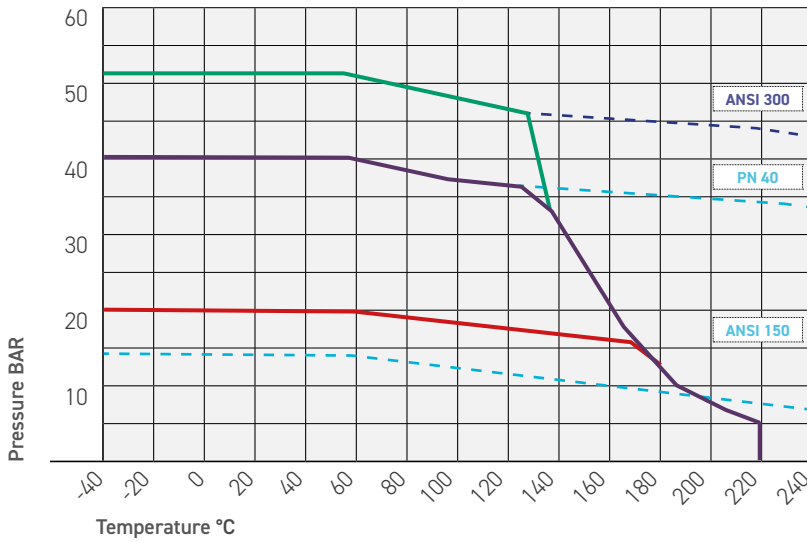

- ANSI 150
- PN 10 - 40
- ANSI 300

DN	$\frac{1}{2}'' \leq DN \leq 2''$ (15 ≤ DN ≤ 50)
P max @ Tmax	5 bar @ 220°C

$2\frac{1}{2}'' \leq DN \leq 4''$

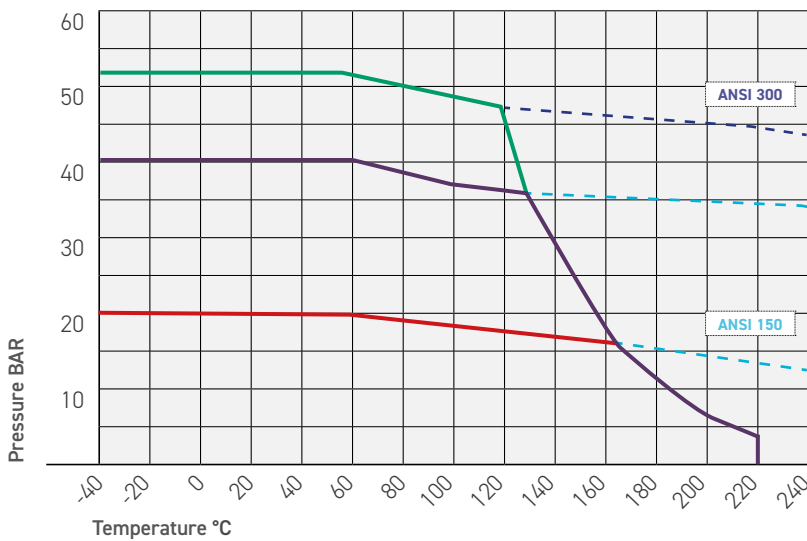

DN	$2\frac{1}{2}'' \leq DN \leq 4''$ (65 ≤ DN ≤ 100)
P max @ Tmax	4 bar @ 220°C

$5'' \leq DN \leq 6''$

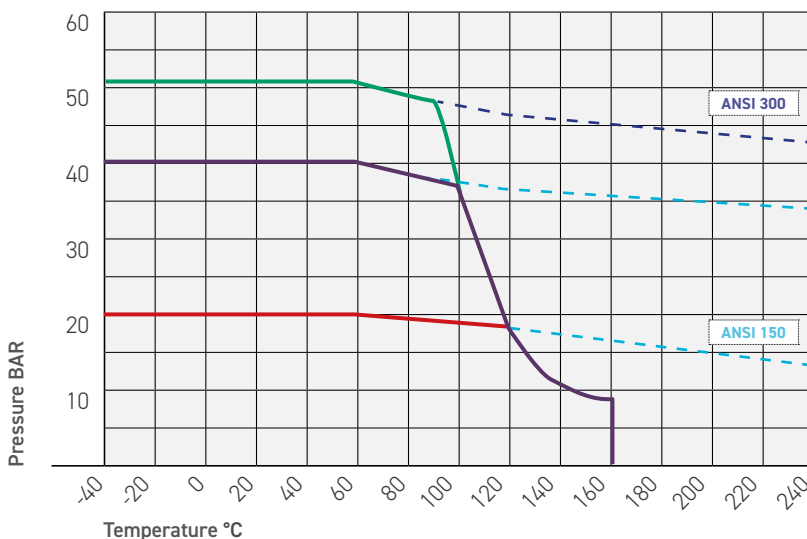

DN	$5'' \leq DN \leq 6''$ (125 ≤ DN ≤ 150)
P max @ Tmax	8 bar @ 160°C





VALVES / VALVOLE: ALFA 10N/10NF - 11N/11NF

PTFE SEATS + METAL CORE / SEDI IN PTFE + AM (ON REQUEST)

$\frac{1}{2}'' \leq DN \leq 2''$

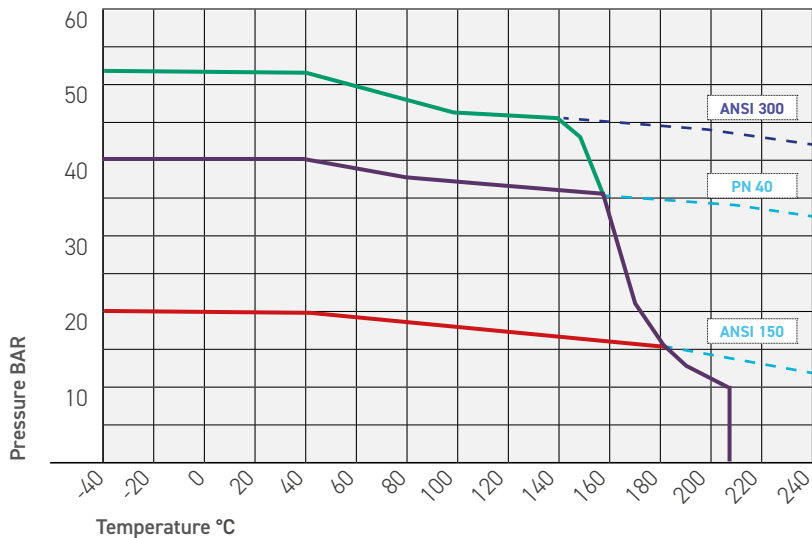

- ANSI 150
- PN 10 - 40
- ANSI 300

DN	$\frac{1}{2}'' \leq DN \leq 2''$ (15 ≤ DN ≤ 50)
P max @ Tmax	10 bar @ 210°C

$2\frac{1}{2}'' \leq DN \leq 4''$

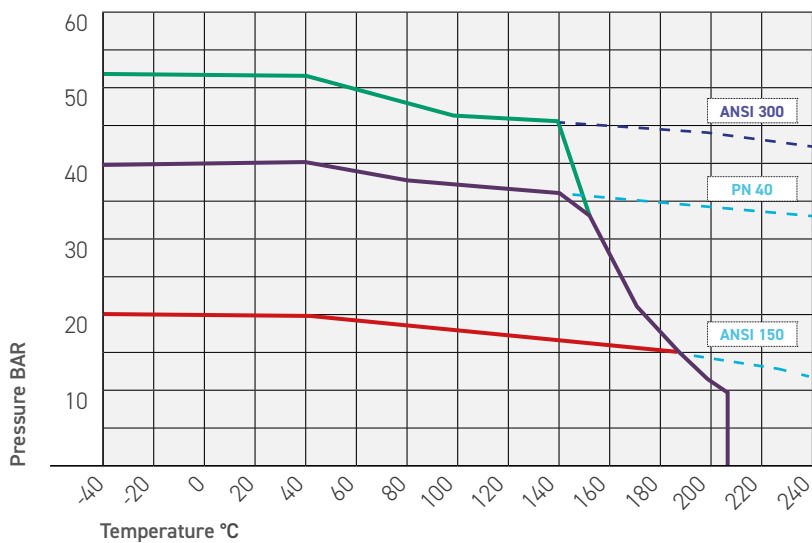

DN	$2\frac{1}{2}'' \leq DN \leq 4''$ (65 ≤ DN ≤ 100)
P max @ Tmax	9 bar @ 210°C

$5'' \leq DN \leq 8''$

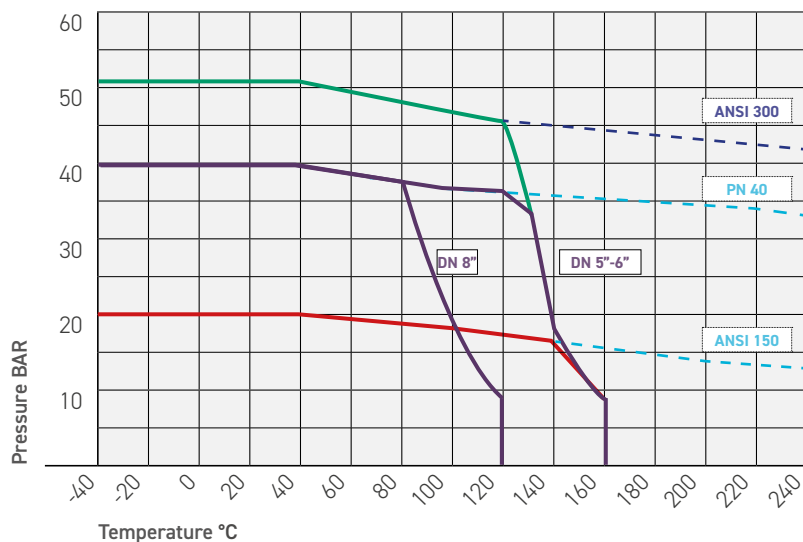

DN	$5'' \leq DN \leq 8''$ (125 ≤ DN ≤ 200)
P max @ Tmax	8 bar @ 160°C (DN 125-150) 8 bar @ 120°C (DN 200)



VALVES / VALVOLE: ALFA 10N/10NF - 11N/11NF PEEK SEATS / SEDI IN PEEK (ON REQUEST)

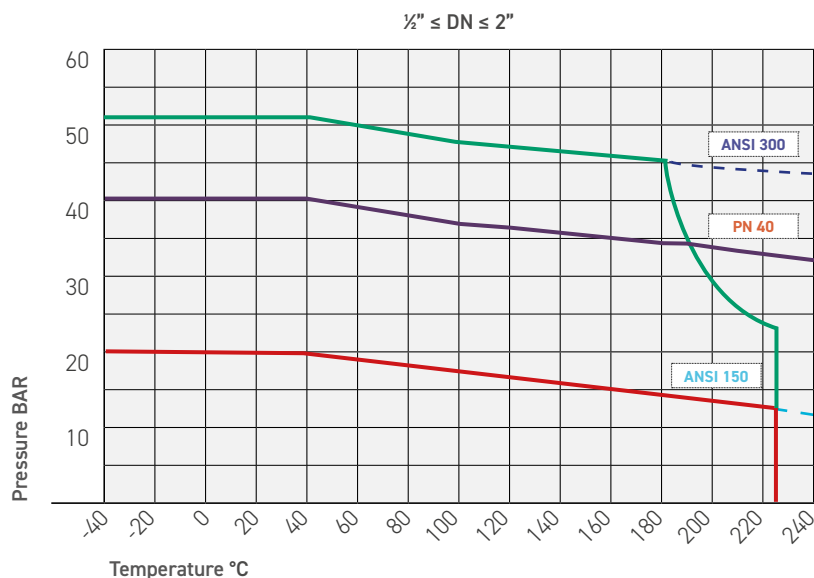

- ANSI 150
- PN 10 - 40
- ANSI 300

DN	$\frac{1}{2}'' \leq DN \leq 2''$ ($15 \leq DN \leq 50$)
P max @ Tmax	12,4 bar @ 230°C (ANSI 150 - PN 10-40) 23 bar @ 230°C (ANSI 300)

VALVES / VALVOLE: ALFA 10HP

TFM/PTFE + METAL CORE SEATS / SEDI IN TFM/PTFE + AM

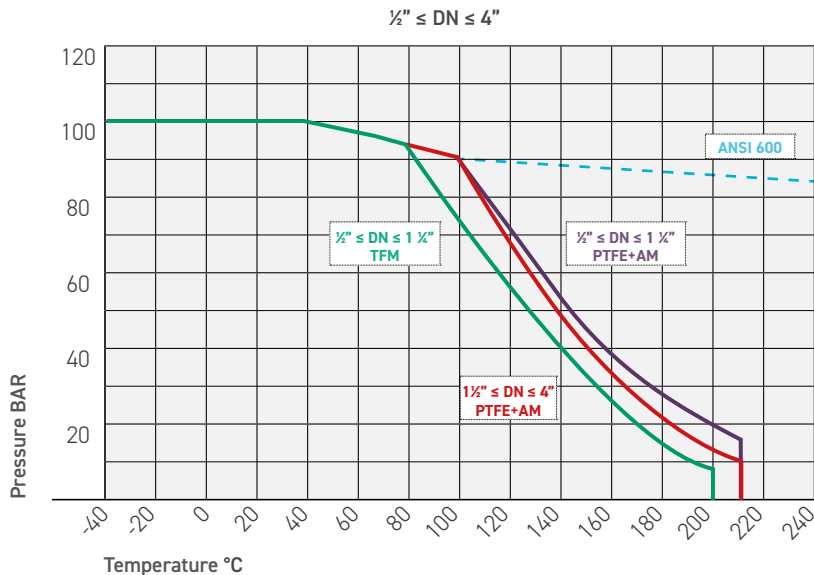

- ANSI 600, $15 \leq DN \leq 32$ - TFM
- ANSI 600, $15 \leq DN \leq 32$ - PTFE + AM
- ANSI 600, $40 \leq DN \leq 100$ - PTFE + AM

DN	$\frac{1}{2}'' \leq DN \leq 1\frac{1}{2}''$ ($15 \leq DN \leq 50$)
P max @ Tmax	6,5 bar @ 200°C (TFM SEATS) 10 bar @ 210°C (PTFE + AM SEATS)

DN	$1\frac{1}{2}'' \leq DN \leq 4''$ ($65 \leq DN \leq 100$)
P max @ Tmax	9 bar @ 210°C (PTFE + AM SEATS)

ADDITIONAL MACHINING

Lavorazioni aggiuntive

SPIRALWOUND EXECUTION / ESECUZIONE PER SPIROMETALLICHE

RESTRICTION FOR DN OR BODY TYPE / LIMITAZIONI SU DN O FINITURA CORPO

DN	FUSO / CASTING	BARRA/BAR
15		
20		
25		
32		
40		
50		
65		
80		
100		
125		
150		
200		

APPLICABLE VALVES / VALVOLE APPLICABILI

A1N (PN 10/40)	A1N (#150)	A1N (#300)	A1H (#600)

- The special closure allows the mounting of spiralwound gaskets to avoid the risk of interference with the pin holes
- Where not applicable is not needed due to valve design (bolted closure instead of threaded closure)

- La ghiera fresata permette il montaggio valvola con guarnizioni spirometalliche, eliminando il rischio di interferenza area di tenuta con i fori spina
- Le valvole su cui non è fattibile presentano progetto con chiusura imbullonata e non avvitata, per cui non si rende necessario differenziare

SMOOTH FINISH / FINITURA SMOOTH FINISH

APPLICABLE VALVES / VALVOLE APPLICABILI

A1N (PN10/40)	A1N (#150)	A1N (#300)	A1H (#600)

- Only applicable for RF valves, it modifies the gasket sealing area roughness from 125-250 AARH to 63-125 AARH

- La finitura Smooth Finish, applicabile solo a valvole RF, porta la finitura del collarino di tenuta ad una rugosità superficiale di 63-125 AARH

PN 06 DRILLING / FORATURA PN 06

RESTRICTION FOR DN OR BODY TYPE / LIMITAZIONI SU DN O FINITURA CORPO

DN	FUSO / CASTING	BARRA/BAR
15		
20		
25		
32		
40		
50		
65	*	*
80	*	
100		
125		
150		
200		

APPLICABLE VALVES / VALVOLE APPLICABILI

A1N (PN 10/40)	A1N (#150)	A1N (#300)	A1H (#600)

- * Drilling done after closure assembling (maintenance not possible)/
Foratura effettuata dopo il montaggio (valvola non manutenzionabile)

- PN 06 drilling is performed to make possible valve assembling on PN 06 line, without modifying other valve features
- Where not applicable is not needed due to valve design

- La foratura PN 06 è realizzata per permettere il montaggio valvola su linee a rating PN 06 senza modificare altre caratteristiche della valvola
- Le valvole su cui non è fattibile presentano ostacoli progettuali.

OPTIONAL EXECUTIONS

Esecuzioni optional



BALANCE HOLE / FORO DI EQUILIBRIO

Balancing hole between ball cavity and upstream pipeline that avoid overpressures. Valve become unidirectional / Equilibra la pressione tra cavità sfera e tubazione a monte, eliminando sovrappressioni. Rende la valvola monodirezionale



CHEVRON RING / PACCO A V

V-Shaped 3 pieces gasket: guarantees maximum tightness from stem area, suitable for every fluid and for vacuum conditions / Tripla guarnizione in PTFE sagomata che garantisce massima tenuta del premistoppa, adatta ad ogni fluido e a condizioni di vuoto



INTEGRAL POCKET SEATS / SEDI INTEGRALI

PTFE integral pocket seats, designed to avoid any potential medium deposit between body and ball / Tenuta integrale in PTFE che avvolge completamente la sfera ed impedisce il deposito di materiale tra sfera e corpo



DOUBLE SEALING EXTENSION / PROLUNGA DOPPIA TENUTA

Extension (100mm) featured by additional gasket kit featured to have double sealing from stem area / Prolunga dotata di set di guarnizioni per garantire una doppia tenuta del premistoppa



CRYOGENIC STEM EXTENSION / ESTENSIONE STELO CRIOGENICA

Special valve and stem execution with 250 mm elongation, suitable for valve usage in cryogenic conditions / Costruzione stelo e valvola con prolunga H 250 mm, idonea ad utilizzo valvola con fluidi criogenici.



LEVER EXTENSION / ESTENSIONE LEVA

Lever extension suitable to operate the valve with insulation coverage / Estensione leva che permette di manovrare la valvola in caso di coibentazione



LOCKING DEVICE / DISPOSITIVO DI BLOCCAGGIO ALTO

Device suitable to safety lock the valve in open or closed position. Can be assembled also on field. FOR INSULATED VALVES / Dispositivo, montabile anche in campo, atto a lucchettare la valvola in posizione di aperto/chiuso. PER VALVOLE COIBENTATE



LOCKING DEVICE / DISPOSITIVO DI BLOCCAGGIO BASSO

Device suitable to safety lock the valve in open or closed position. Can be assembled also on field / Dispositivo, montabile anche in campo, atto a lucchettare la valvola in posizione di aperto/chiuso



VALVE DEGREASING FOR OXYGEN SERVICE / VALVOLE SGRASSATE PER USO OSSIGENO

Valves fully degreased for oxygen service (O₂) use, cleaned with Ultrasonic Devices, assembled and tested in white room / Valvole sgrassate per uso su ossigeno (O₂): componenti puliti con ultrasuoni, assemblaggio e test in camera bianca.



Please contact sales/Tech Dept for application on requested valve / Contattare sales/tech dept per applicabilità sulla valvola richiesta

Alnab Armatur AB
Ögärdesvägen 4B
SE-433 30 Partille

www.alnab.se
alnab@alnab.se
Tel +46 31 449450



Applicazioni per mercati specifici

FOOD MARKET

ALFA 10 CALL

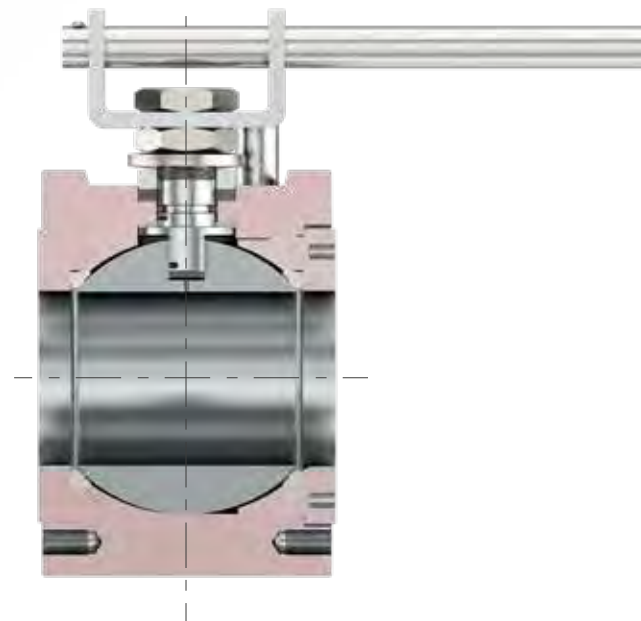

FOOD & BEVERAGE VALVE MARKET / VALVOLA SPECIFICA PER IL MERCATO ALIMENTARE

Featured by body and closure special machining designed to minimize body cavity clearance/

Caratterizzata da lavorazione interna corpo e chiusura tale da minimizzare la cavità corpo

FEATURES / CARATTERISTICHE

- Bar stock machining, ASTM A105 or ASTM A182 F316/316L / Costruzione corpo da barra, corpo in ASTM A105 o ASTM A182 F316/316L
- Size: from DN 15 to DN 50 / Diametro: da DN 15 a DN 50
- Rating: PN 10-40 or ANSI 150 / Rating: PN 10-40 o ANSI 150
- Available for heating jacket application / Disponibile per applicazione camicia di riscaldamento
- Available for internal (body and ball) polished surface, with roughness grade Ra = 0,8 / Possibilità di avere lavorazione interna corpo e sfera lucidata a Ra 0,8

CERTIFICATION / CERTIFICAZIONE

- Stainless steel valve available with MOCA certification (Materials and object in contact with food - (Regulation (CE) n. 1935/2004 & Regulation (CE) n. 2023/2006) / Valvola in 316 fornibile certificata moca (Materiale e Oggetti per Contatto Alimentare - (Direttiva (CE) n. 1935/2004 & Direttiva (CE) n. 2023/2006).



M.O.C.A. (EC) 1935/2004



For cost and lead time contact Alfa Valvole / Per extra costo e tempi di fornitura contattare Alfa Valvole

Alnab Armatur AB
Ögårdesvägen 4B
SE-433 30 Partille

Applicazioni per mercati specifici

TRANSPORTATION MARKET

ALFA 10 VAG

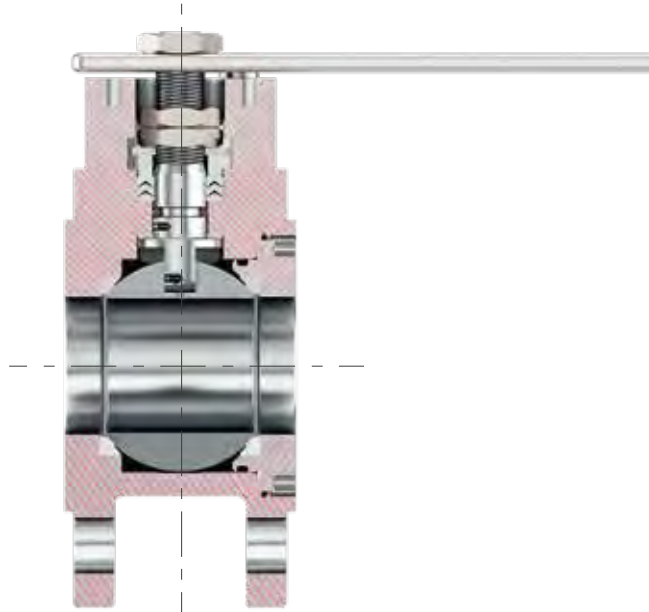

TRANSPORTATION (RAIL & ROAD) VALVE MARKET / VALVOLA SPECIFICA PER IL MERCATO FERROVIARIO

Featured by specific design, light and compact, suitable for assembly on rail tank with locking devices and additional safety devices
Caratterizzata da design specifico, leggero e compatto, per permettere il montaggio su vagoni con lucchettaggi e fermi di sicurezza aggiuntivi

FEATURES / CARATTERISTICHE

- Casting technology, ASTM A351 CF8M body / Costruzione corpo da fusione, corpo in ASTM A351 CF8M
- Size from DN 40 to DN 100 / Diametro: da DN 40 a DN 100
- Rating: PN 16 / Rating: PN 16
- Available for heating jacket application / Disponibile per applicazione camicia di riscaldamento
- Wafer construction, smooth holes on flanges / Costruzione wafer, fori lisci sulle flange
- Virgin PTFE gaskets / Guarnizioni in PTFE vergine

CERTIFICATION / CERTIFICAZIONE

- Valve covered by T-PED certification according to ADR/RID and EN 14432:2014, produced under I.I.S (in-house inspection service) / Valvola coperta da certificazione di tipo T-PED secondo ADR/RID e EN14432 e sottoposta a I.I.S (in-house inspection service)



π

Cert. Nr. ADR/RID/ADN-T-AFV 002/004-17-ITA



For cost and lead time contact Alfa Valvole / Per extra costo e tempi di fornitura contattare Alfa Valvole

Alnab Armatur AB
Ögårdesvägen 4B
SE-433 30 Partille

www.alnab.se
alnab@alnab.se
Tel +46 31 449450



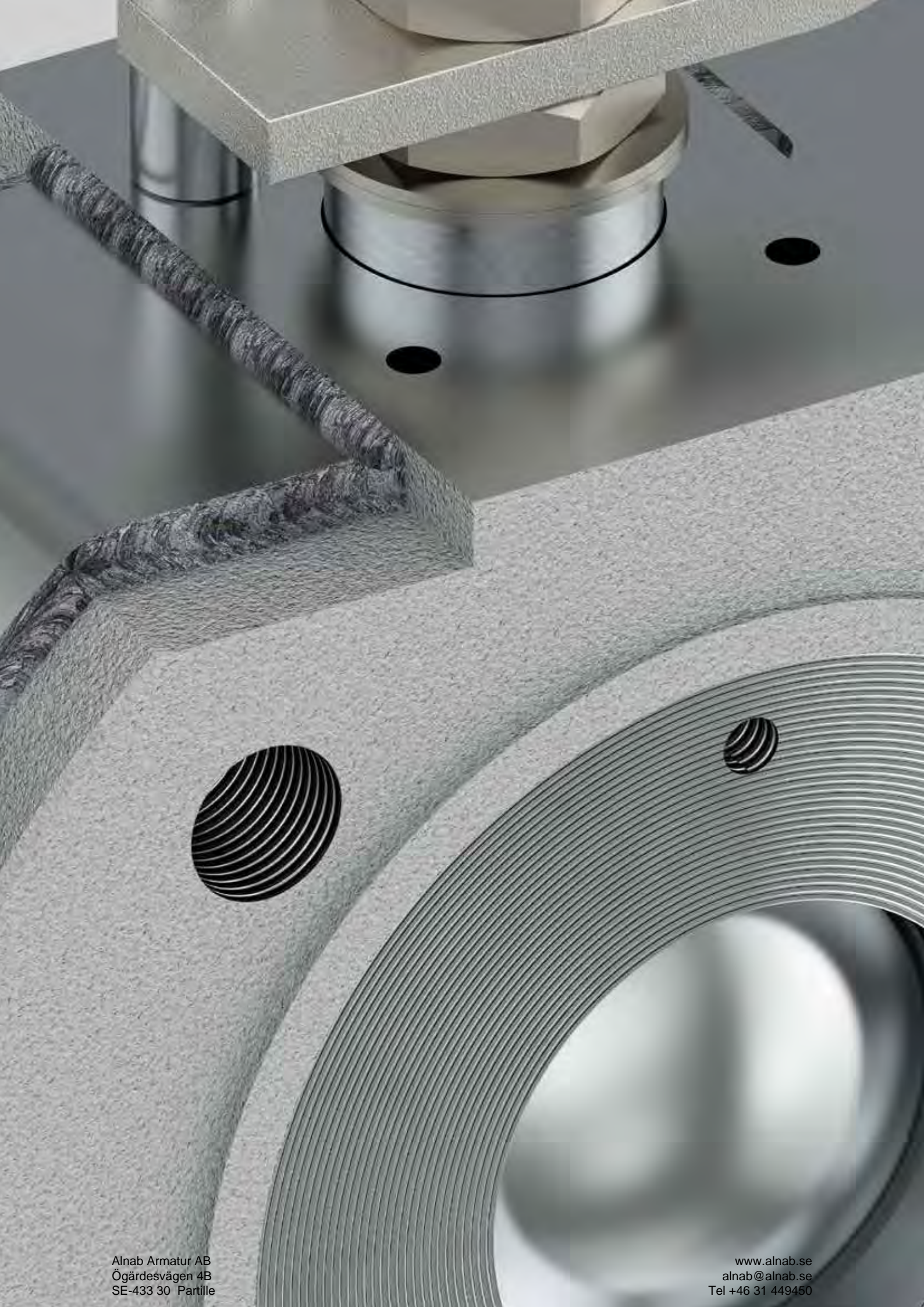



Alfa Valvole S.r.l.
20010 Casorezzo (MI), Viale del Lavoro, 19
tel +39 02 90296206
alfavalvole.it