

BPHE

BRAZED PLATE HEAT EXCHANGERS



BRAZED PLATE HEAT EXCHANGERS

Brazed plate heat exchangers are the perfect solution that allows for maintaining high thermal performance at low operating costs.

Wide range of types, sizes, and numbers of plates and connections allows for optimizing the selection to particular application.

Copper or stainless brazing and the double wall option offer additional application possibilities. Brazed plate heat exchangers guarantee reliable, long-term operation.

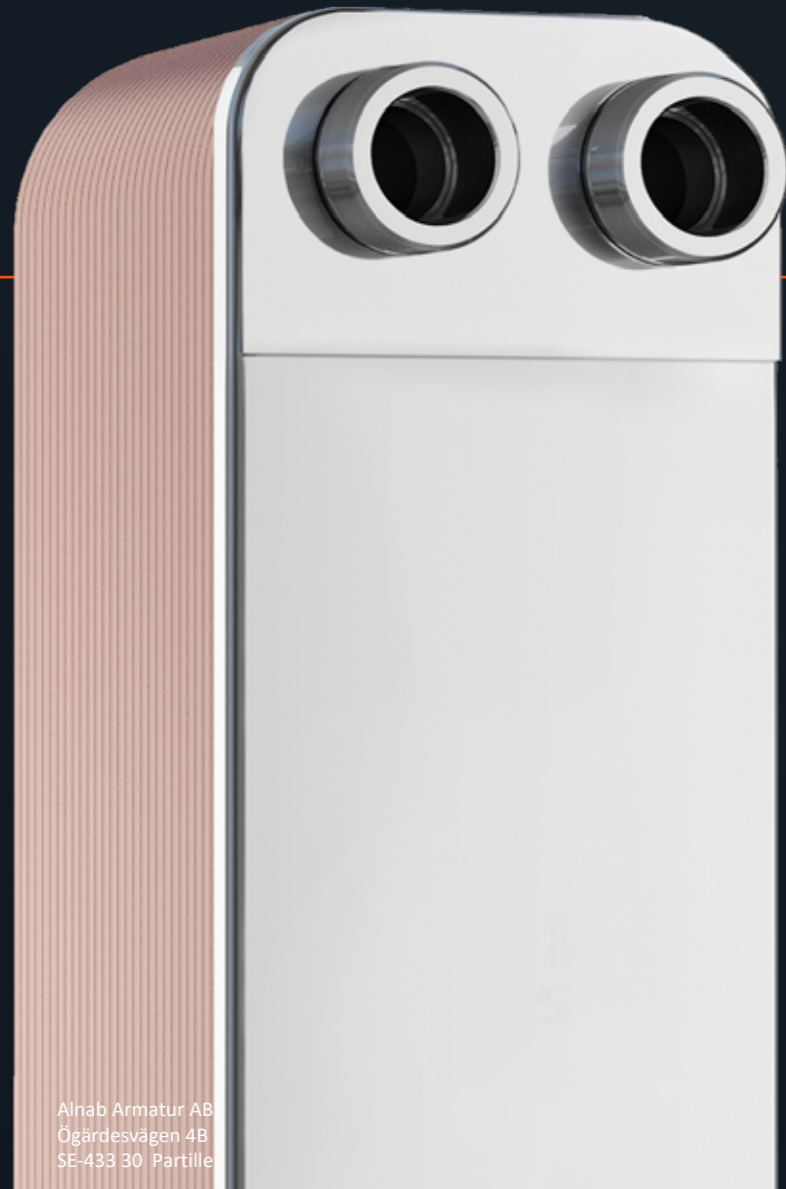

WHY CHOOSE **HEXONIC** BRAZED PLATE HEAT EXCHANGERS?



HIGH PERFORMANCE

Heat exchangers are designed for very efficient operations within a wide range of applications. They guarantee compact and flexible solutions.



WIDE RANGE OF APPLICATIONS

Heat exchangers are used in central heating and domestic hot water systems, ventilation, technological and air-conditioning installations, as well as in heat pumps and ice water generators.



CERTIFICATES AND STANDARDS

Manufactured in accordance with ASME, PED, EAC.



RELIABILITY

Advanced technology and high quality materials offer durability and reliability.



FLEXIBLE DESIGN

We offer 1- or 2-pass versions with a choice of different types of connections such as: dual (external thread / soldering), internal thread, Victaulic, stainless steel flange, carbon steel flange.



EASY SELECTION

User-friendly CAIRO Selection Software makes the selection process easy.

L

BRAZED PLATE HEAT EXCHANGERS

DEDICATED TO HEATING OR COOLING SYSTEMS.

APPLICATION



DOMESTIC HOT WATER SYSTEMS



CENTRAL HEATING SYSTEMS



SOLAR AND GEOTHERMIC HEATING SYSTEMS



INSTALLATIONS WITH HEAT PUMP



INSTALLATIONS WITH FIREPLACE WITH WATER JACKET

ADVANTAGES



HIGH HEAT TRANSFER COEFFICIENT



EASY ASSEMBLY AND DISMANTLE



COMPACT SIZE



RESISTANCE TO HIGH TEMPERATURE AND PRESSURE



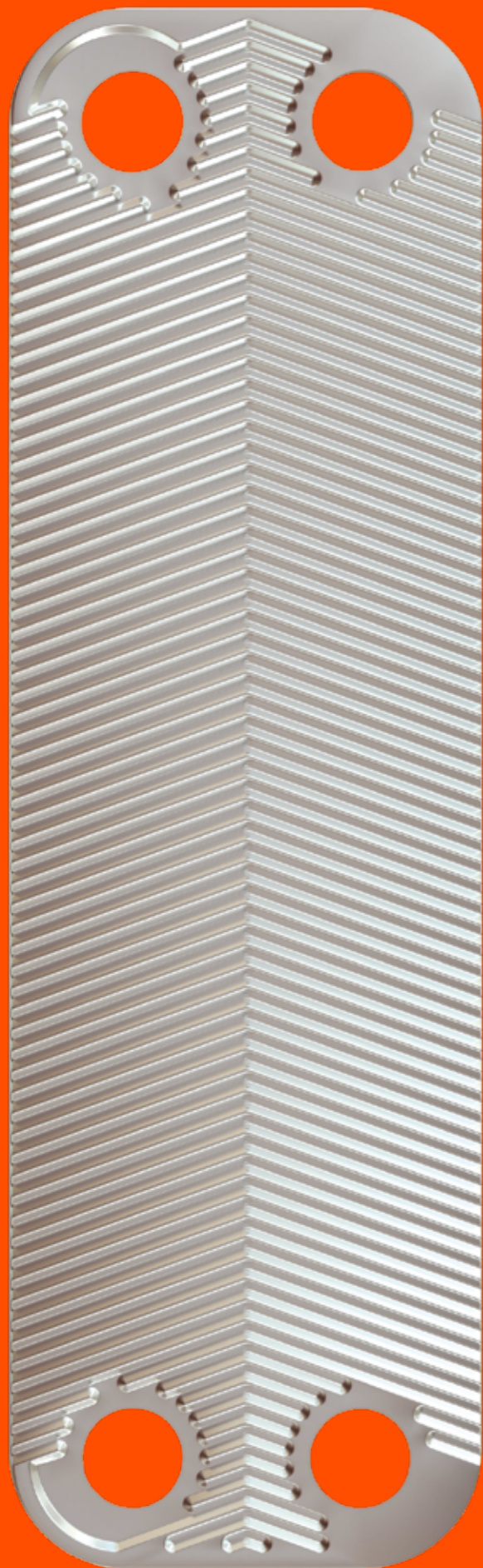

MICROCHANNEL BRAZED
PLATE HEAT EXCHANGER

8%
↑

**INCREASE OF HEAT EXCHANGE
EFFICIENCY BY UP TO 8%**
COMPARING TO OTHER COMPETITIVE
MICROCHANNEL HEAT EXCHANGERS

9%
↓

**REDUCTION OF FLOW
RESISTANCE BY UP TO 9%**
COMPARING TO THE MOST
EFFICIENT MICROCHANNEL HEAT
EXCHANGER ON THE MARKET

35%
↑

**INCREASE OF HEAT EXCHANGE
EFFICIENCY BY 35%**
COMPARING TO EXCHANGERS
WITH STANDARD HEAT PLATES



**HIGHER FLOW TURBULENCE
ENHANCES HEAT EXCHANGE**
THANKS TO OPTIMIZATION
OF FLOW VELOCITY

EXEMPLAR DESIGNATION

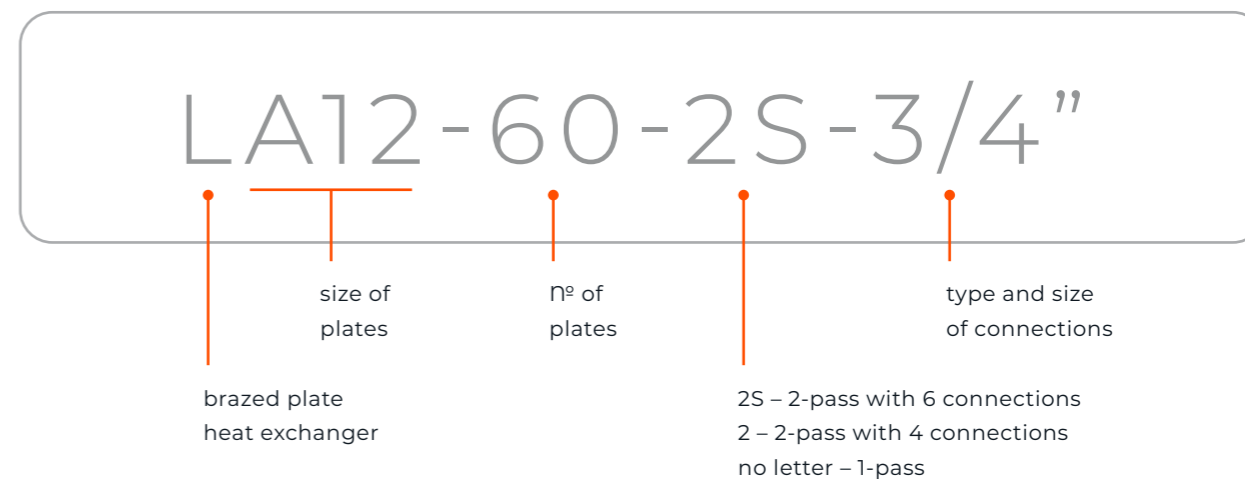

PRODUCT LINE

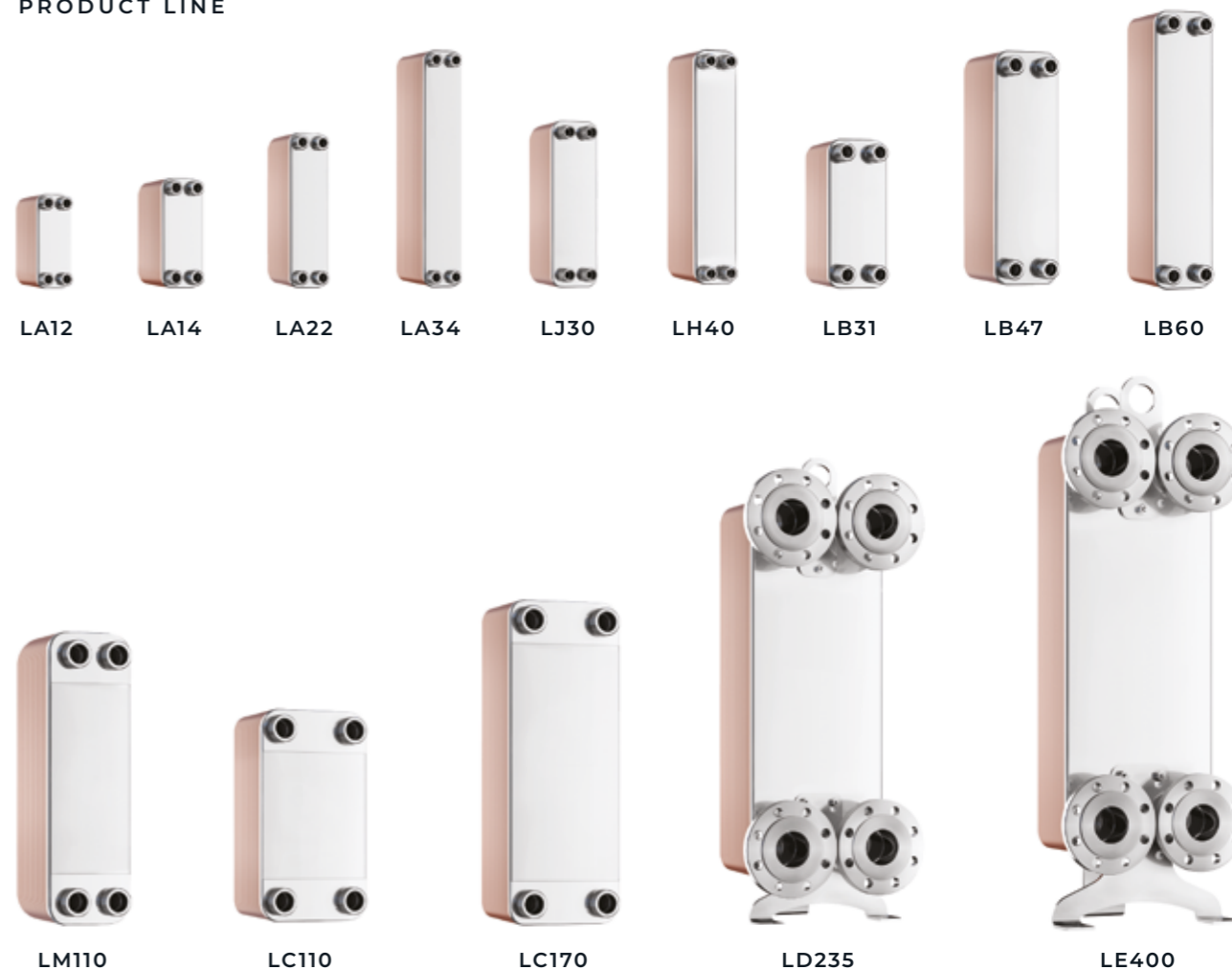

TECHNICAL DATA

STANDARD LOCATION OF CONNECTIONS

1-PASS HEAT EXCHANGER

- K1 / K4** — inlet / outlet hot side
K3 / K2 — inlet / outlet cold side

2-PASS HEAT EXCHANGER

- D4 / K4** — inlet / outlet hot side
K3 / D3 — inlet / outlet cold side

2-PASS WITH 6 CONNECTIONS

ADDITIONALLY:

- K1** — vent connection / inlet of central heating return
K2 — vent connection / inlet of domestic hot water circulation return

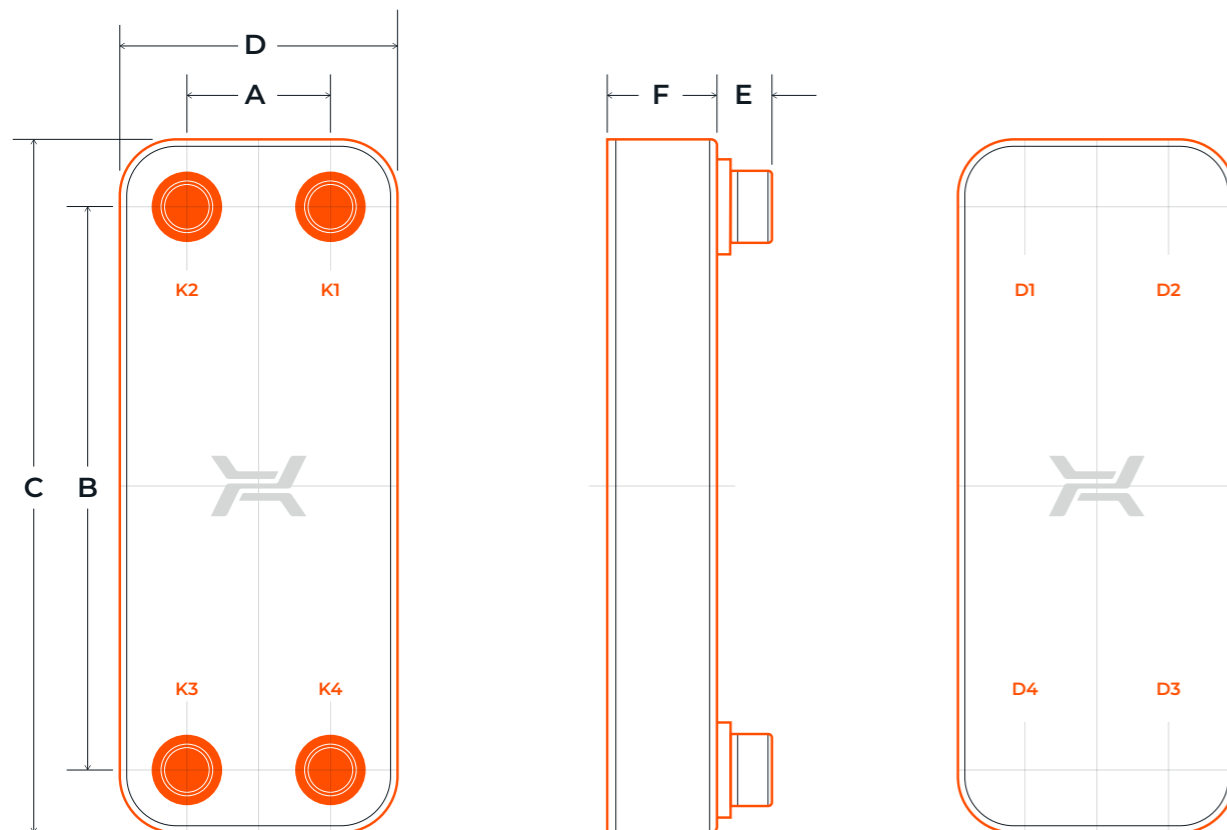

MATERIALS

- STAINLESS STEEL
 — COPPER BRAZING

EXEMPLARY MEDIA

- WATER
 — PROPYLENE GLYCOL SOLUTIONS
 — GROUP II FLUIDS
 — OTHER (CONSULT THE MANUFACTURER)

WORKING PARAMETERS

- MAX. TEMPERATURE — 230°C / 446°F
 LJ — 160°C / 320°F

- MIN. TEMPERATURE — -195°C / -319°F
 FOR FLANGE CS — 0°C / 32°F

MAX. PRESSURE

- LA, LB, LH — 3 MPA / 435 PSI
 LM, LC, LD, LE — 2,5 MPA / 363 PSI
 LJ — 1,6 MPA / 232 PSI

TECHNICAL PARAMETERS

Type	Dimensions												max. No. of plates	Mass	
	A		B		C		D		E		F			kg	lb
	mm	in	mm	in	mm	in	mm	in	mm	in	mm	in			
LA12	40	1.6	154	6.1	190	7.5	72	2.8	16/20	0.6/0.8	9 + 2,45 × NP	0.35 + 0.10 × NP	60	0,4 + 0,049 × NP	0.88 + 0.11 × NP
LA14	42	1.7	164	6.5	203	8.0	81	3.2	16/20	0.6/0.8	9 + 2,30 × NP	0.35 + 0.09 × NP	60	0,6 + 0,049 × NP	1.32 + 0.11 × NP
LA22	42	1.7	260	10.2	299	11.8	81	3.2	16/20	0.6/0.8	9 + 2,30 × NP	0.35 + 0.09 × NP	60	0,8 + 0,073 × NP	1.76 + 0.16 × NP
LA34	42	1.7	432	17.0	471	18.5	81	3.2	16/20	0.6/0.8	9 + 2,30 × NP	0.35 + 0.09 × NP	60	1,2 + 0,116 × NP	2.65 + 0.26 × NP
LJ30	46	1.8	270	10.6	318	12.5	98	3.9	20	0.8	9 + 1,70 × NP	0.35 + 0.07 × NP	60	1,1 + 0,064 × NP	2.43 + 0.14 × NP
LH40	43	1.7	415	16.3	461	18.1	89	3.5	28	1.1	10 + 2,25 × NP	0.39 + 0.09 × NP	60	1,7 + 0,134 × NP	3.75 + 0.30 × NP
LB31	68	2.7	232	9.1	286	11.3	123	4.8	28	1.1	10 + 2,35 × NP	0.39 + 0.09 × NP	150	1,6 + 0,114 × NP	3.53 + 0.25 × NP
LB47	68	2.7	360	14.2	417	16.4	123	4.8	28	1.1	10 + 2,35 × NP	0.39 + 0.09 × NP	150	2,1 + 0,168 × NP	4.63 + 0.37 × NP
LB60	68	2.7	480	18.9	538	21.2	123	4.8	28	1.1	10 + 2,35 × NP	0.39 + 0.09 × NP	150	2,6 + 0,219 × NP	5.73 + 0.48 × NP
LM110	91	3.6	520	20.5	619	24.4	190	7.5	48	1.9	10 + 2,60 × NP	0.39 + 0.10 × NP	200	8,4 + 0,408 × NP	18.52 + 0.90 × NP
LC110	170	6.7	378	14.9	466	18.4	258	10.2	28/38; 100	1.1/1.5; 3.9	11 + 2,40 × NP	0.43 + 0.09 × NP	200	8,7 + 0,408 × NP	19.18 + 0.90 × NP
LC170	170	6.7	600	23.6	688	27.1	258	10.2	28/38; 100	1.1/1.5; 3.9	11 + 2,40 × NP	0.43 + 0.09 × NP	200	11,5 + 0,617 × NP	25.35 + 1.36 × NP
LD235	204	8.0	682	26.9	788	31.0	310	12.2	100	3.9	13 + 2,5 × NP	0.51 + 0.10 × NP	280	40 + 0,828 × NP	88.18 + 1.83 × NP
LE400	240	9.5	861	33.9	1008	39.7	387	15.2	93	3.7	17 + 2,75 × NP	0.67 + 0.11 × NP	400	74,3 + 1,625 × NP	163.80 + 3.58 × NP

NP – number of plates | dim. F +/-3%

All dimensions and technical data are approximate only and may be changed without further notice.

LUNA

BRAZED PLATE HEAT EXCHANGERS

ENTIRELY MADE OF STAINLESS MATERIALS DESIGNED TO MAINTAIN HIGH SANITARY STANDARDS.

APPLICATION

WHEN HIGH LEVEL OF HYGIENE IS CRUCIAL



SYSTEMS WITH DEMINERALIZED WATER



DOMESTIC HOT WATER SYSTEMS



COOLING SYSTEMS WITH HIGH HYGIENIC STANDARDS

WHEN RELIABILITY IS ESSENTIAL



CENTRAL HEATING SYSTEMS



SYSTEMS WITH AGGRESSIVE MEDIA

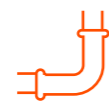

SYSTEMS WITH GALVANIZED PIPES



INDUSTRIAL COOLING SYSTEMS



HYDRAULIC OIL COOLING

ADVANTAGES



STAINLESS BRAZING ALLOWS HOMOGENEOUS CONSTRUCTION



HIGH SANITARY STANDARDS



RESISTANCE TO HIGH TEMPERATURE AND PRESSURE



RESISTANCE TO CORROSION



HIGH DURABILITY



WIDE RANGE OF APPLICATIONS



NO COPPER IONS IN THE WATER



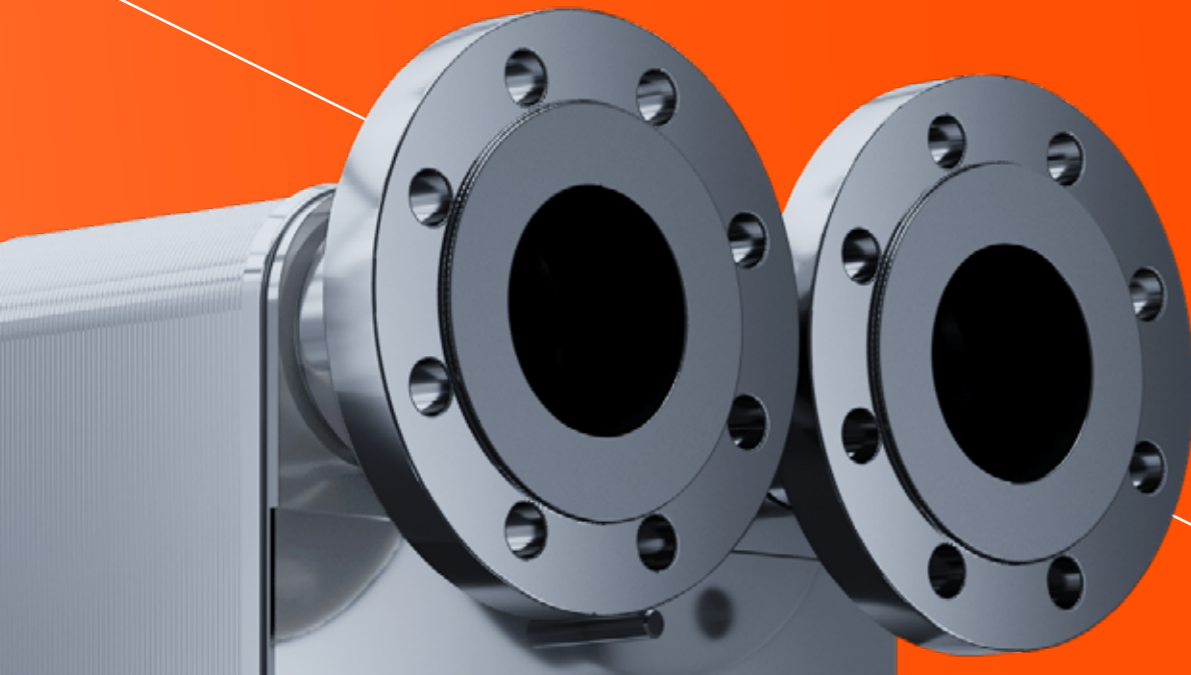

EXEMPLAR DESIGNATION

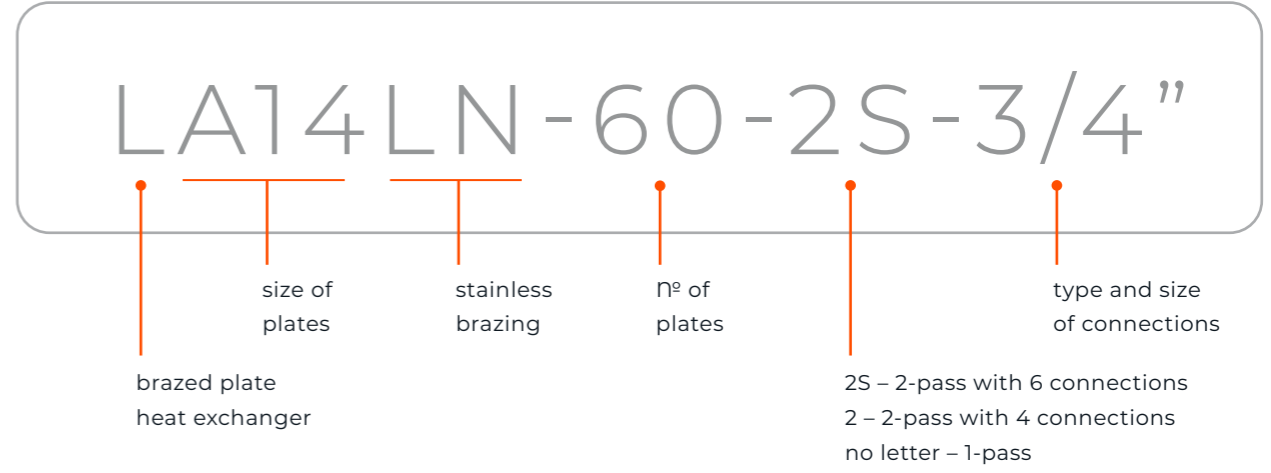

PRODUCT LINE



TECHNICAL DATA

STANDARD LOCATION OF CONNECTIONS

1-PASS HEAT EXCHANGER

- K1 / K4** — inlet / outlet hot side
- K3 / K2** — inlet / outlet cold side

2-PASS HEAT EXCHANGER

- D4 / K4** — inlet / outlet hot side
- K3 / D3** — inlet / outlet cold side

2-PASS WITH 6 CONNECTIONS

ADDITIONALLY:

- K1** — vent connection / inlet of central heating return
- K2** — vent connection / inlet of domestic hot water circulation return

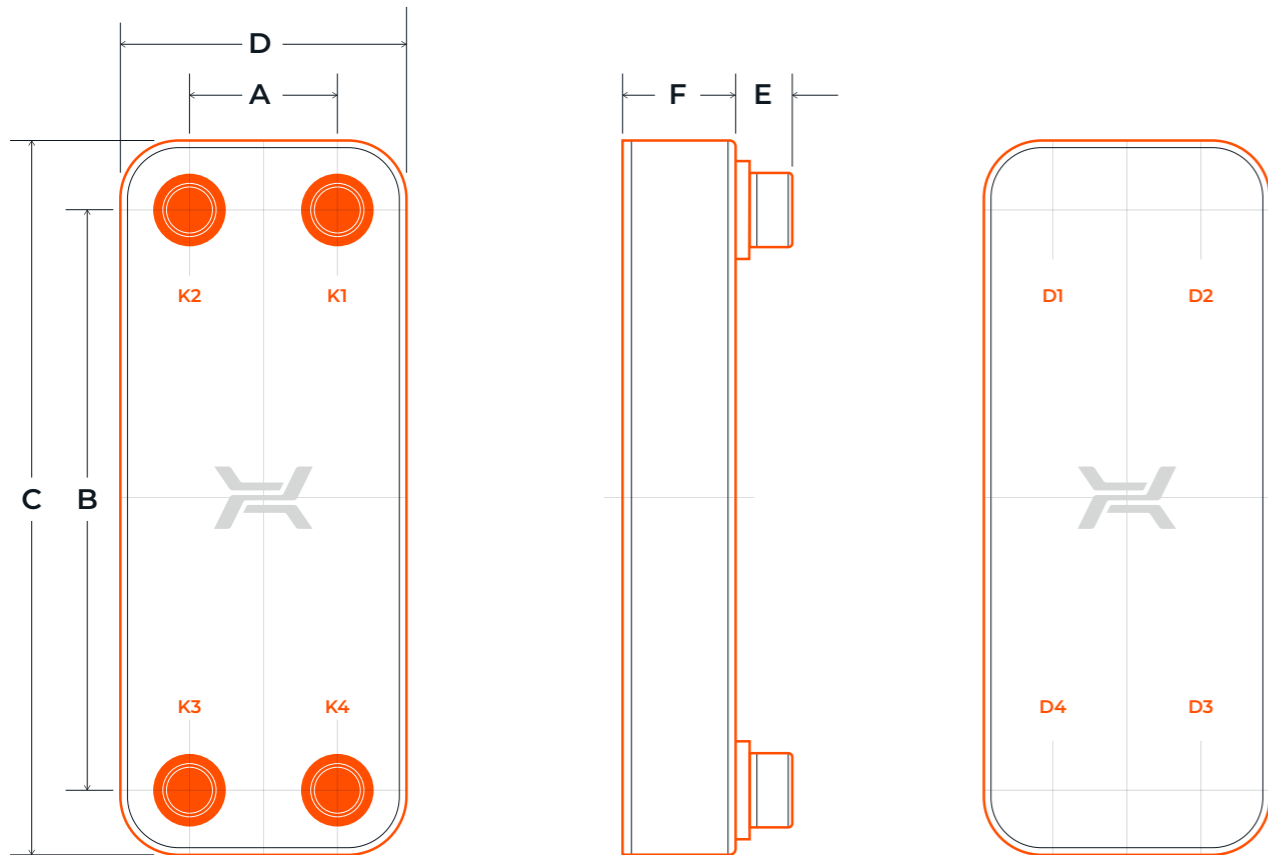

MATERIALS

- STAINLESS STEEL
- STAINLESS BRAZING

EXEMPLARY MEDIA

- WATER
- PROPYLENE
- GROUP II FLUIDS
- OTHER (CONSULT THE MANUFACTURER)

WORKING PARAMETERS

- MAX. TEMPERATURE — 200°C / 392°F
- MIN. TEMPERATURE — -195°C / -319°F
- LM LN — -101°C / -150°F
- MAX. PRESSURE
- LA LN, LB LN — 2 MPA / 290 PSI
- LM LN, LC LN, LD LN — 1,6 MPA / 232 PSI

TECHNICAL PARAMETERS

Type	Dimensions												max n° of plates	Mass	
	A		B		C		D		E		F			kg	lb
	mm	in	mm	in	mm	in	mm	in	mm	in	mm	in			
LA14LN	42	1.7	164	6.5	203	8.0	81	3.2	16	0.6	9 + 2,3 × NP	0.35 + 0.09 × NP	60	0,6 + 0,054 × NP	1.32 + 0.12 × NP
LA22LN	42	1.7	260	10.2	299	11.8	81	3.2	16	0.6	9 + 2,3 × NP	0.35 + 0.09 × NP	60	0,8 + 0,075 × NP	1.76 + 0.17 × NP
LA34LN	42	1.7	432	17.0	471	18.5	81	3.2	16	0.6	9 + 2,3 × NP	0.35 + 0.09 × NP	60	1,2 + 0,112 × NP	2.65 + 0.25 × NP
LB31LN	68	2.7	232	9.1	286	11.3	123	4.8	28	1.1	10 + 2,35 × NP	0.39 + 0.09 × NP	150	1,6 + 0,126 × NP	3.53 + 0.28 × NP
LB47LN	68	2.7	360	14.2	417	16.4	123	4.8	28	1.1	10 + 2,35 × NP	0.39 + 0.09 × NP	150	2,2 + 0,174 × NP	4.85 + 0.38 × NP
LB60LN	68	2.7	480	18.9	538	21.2	123	4.8	28	1.1	10 + 2,35 × NP	0.39 + 0.09 × NP	150	2,7 + 0,219 × NP	5.95 + 0.48 × NP
LM110LN	91	3.6	520	20.5	619	24.4	190	7.5	48	1.9	10 + 2,6 × NP	0.39 + 0.10 × NP	180	14,68 + 0,864 × NP	6.66 + 0.392 × NP
LC110LN	170	6.7	378	14.9	466	18.4	258	10.2	28;100	1.1; 3.9	11 + 2,4 × NP	0.43 + 0.09 × NP	180	9,1 + 0,454 × NP	20.06 + 0.99 × NP
LC170LN	170	6.7	600	23.6	688	27.1	258	10.2	28;100	1.1; 3.9	11 + 2,4 × NP	0.43 + 0.09 × NP	180	11,9 + 0,642 × NP	26.24 + 1.41 × NP
LD235LN	204	8.0	682	26.9	788	31.0	310	12.2	100	3.9	13 + 2,5 × NP	0.51 + 0.1 × NP	160	40,8 + 0,049 × NP	89.95 + 0.11 × NP

NP – number of plates | dim. F+/-3%

All dimensions and technical data are approximate only and may be changed without further notice.

R

BRAZED PLATE HEAT EXCHANGERS

DESIGNED FOR USE IN COOLING
OR HEATING INSTALLATIONS.
REFRIGERANT EVAPORATORS,
CONDENSERS AND ECONOMIZERS.

APPLICATION



CHILLERS

REFRIGERATION
UNITSHEAT
PUMPSICE WATER
GENERATORSCOOLING SYSTEMS
WITH SPECIAL
CONSTRUCTION

ADVANTAGES

OUTSTANDING
RELIABILITYOPTIMIZED
FOR MODERN
REFRIGERANTSRESISTANCE TO
CYCLIC FATIGUESPECIAL CHANNEL
PATTERN ENSURES
EFFECTIVE
EVAPORATION
OR CONDENSATIONRESISTANCE
TO FREEZING

EVAPORATORS

A two-phase refrigerant is sent to the bottom welded connection of the exchanger. Flowing through the channels it evaporates completely while acquiring the required degree of overheating. Water or glycol flows in counter-current flow.

CONDENSERS

Hot refrigerant vapours are sent to the top welded connection of the exchanger. Flowing through the channels they condense while acquiring the required degree of subcooling. Water and glycol flows in counter-current flow.

RDS SYSTEM

Refrigerant Distribution System is a unique system of dynamical distribution of a boiling agent which has been developed by Hexonic for evaporators with higher refrigerating capacity.

This system ensures a balanced distribution of the agent inside the channels and simultaneously reduces the fluctuations in vapour overheating.

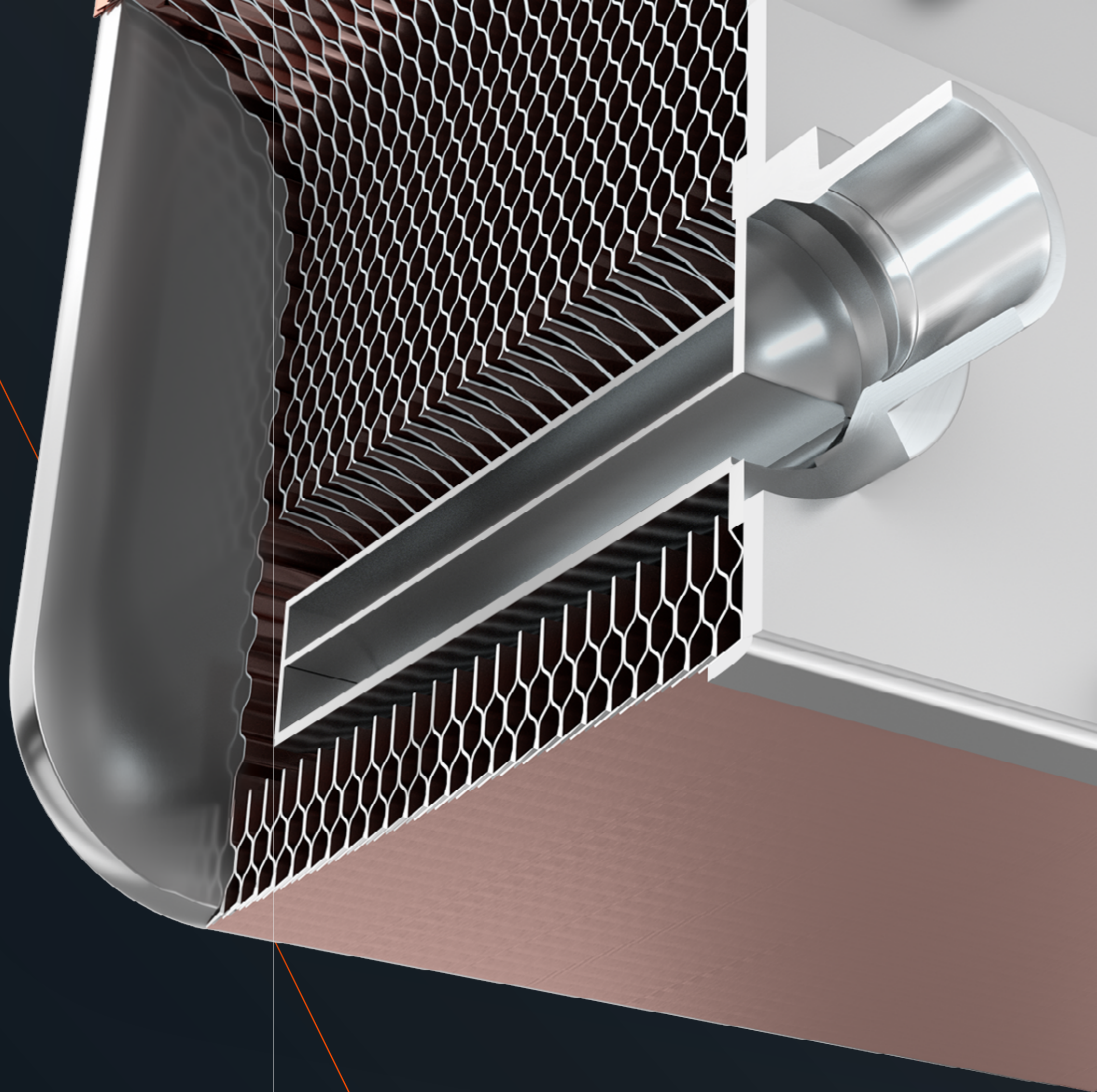



EXEMPLAR DESIGNATION

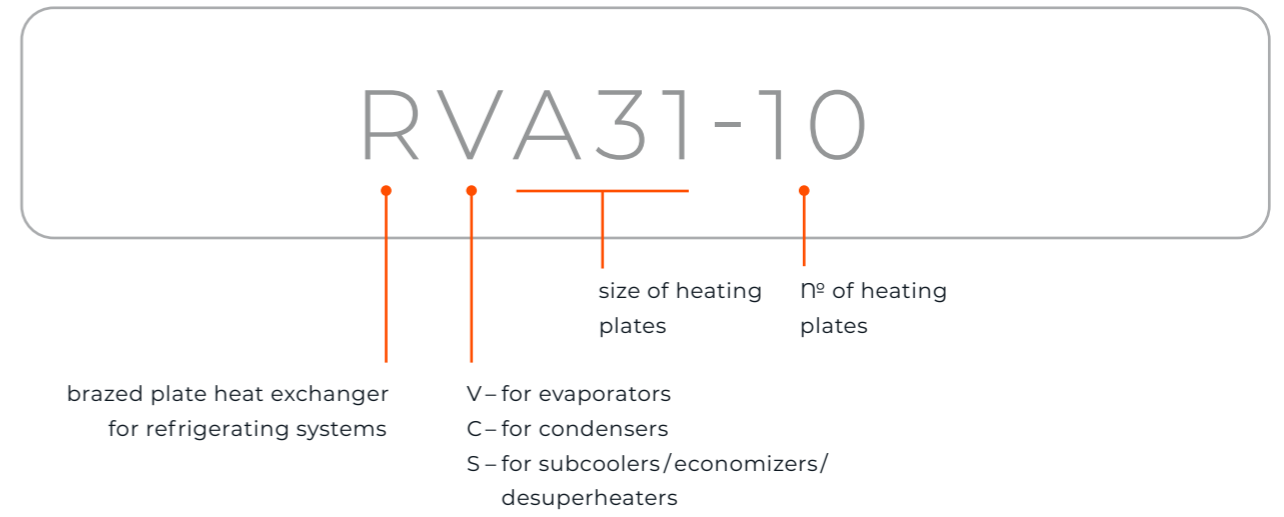

PRODUCT LINE



TECHNICAL DATA

STANDARD LOCATION OF CONNECTIONS

(DEPENDING ON WHETHER IT IS EVAPORATOR OR CONDENSER)

- K 4 / K 1 — inlet /outlet of refrigerant
- K 3 / K 2 — inlet /outlet of water or glycol

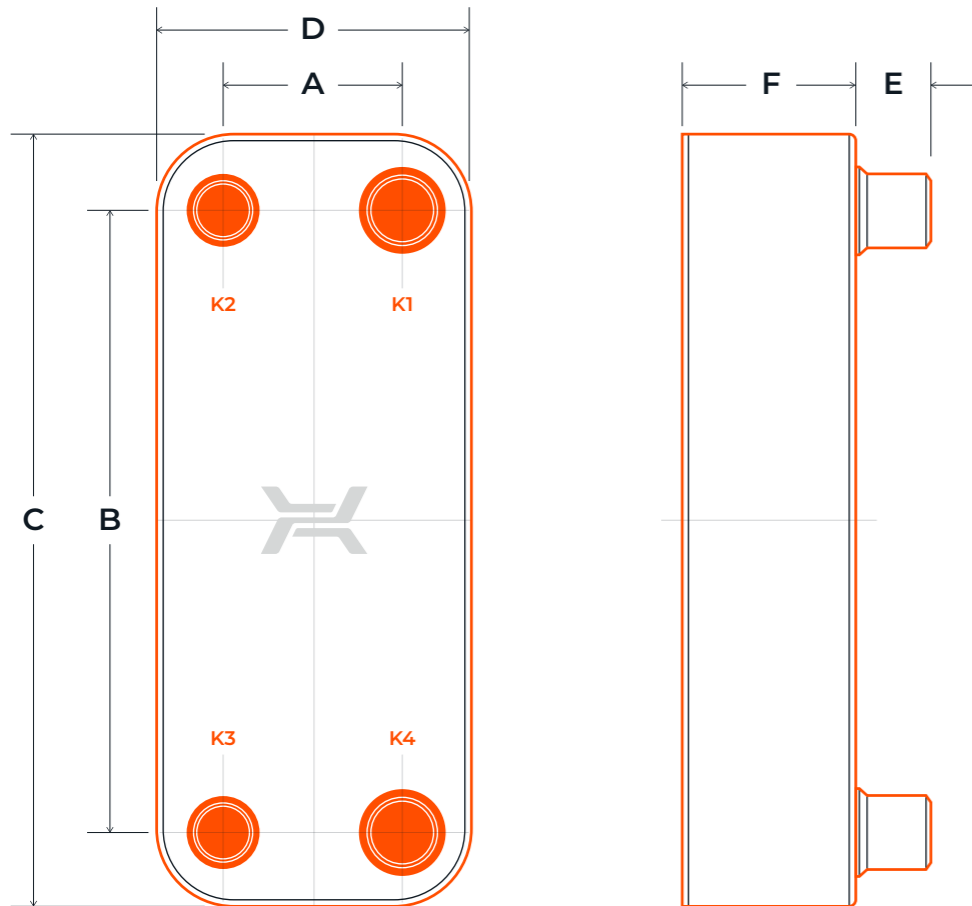

MATERIALS

- STAINLESS STEEL
- COPPER BRAZING

EXEMPLARY MEDIA

REFRIGERANT SIDE

- REFRIGERANTS

OTHER SIDE

- WATER
- PROPYLENE GLYCOL SOLUTIONS
- GROUP II FLUIDS
- OTHER (CONSULT THE MANUFACTURER)

WORKING PARAMETERS

MAX. TEMPERATURE — 150°C / 302°F

MIN. TEMPERATURE — -195°C / -319°F

MAX. PRESSURE

REFRIGERANT SIDE — 4,5 MPA / 653 PSI

WATER, GLYCOL SIDE — 2,5 MPA / 363 PSI

TECHNICAL PARAMETERS

Type	Dimensions												Weight	
	A		B		C		D		E		F		kg	lb
	mm	in	mm	in	mm	in	mm	in	mm	in	mm	in	kg	lb

EVAPORATORS

RVA14	42	1,7	164	6,5	203	8,0	81	3,2	16	0,6	9 + 2,3 × NP	0,35 + 0,09 × NP	0,7 + 0,049 × NP	1,54 + 0,11 × NP
RVA22	42	1,7	260	10,2	299	11,8	81	3,2	16	0,6	9 + 2,3 × NP	0,35 + 0,09 × NP	0,9 + 0,073 × NP	1,98 + 0,16 × NP
RVA34	42	1,7	432	17,0	471	18,5	81	3,2	16	0,6	9 + 2,3 × NP	0,35 + 0,09 × NP	1,3 + 0,116 × NP	2,87 + 0,26 × NP
RVB31	68	2,7	232	9,1	286	11,3	123	4,8	28	1,1	10 + 2,35 × NP	0,39 + 0,09 × NP	1,7 + 0,114 × NP	3,75 + 0,25 × NP
RVB47	68	2,7	360	14,2	417	16,4	123	4,8	28	1,1	10 + 2,35 × NP	0,39 + 0,09 × NP	2,3 + 0,168 × NP	5,07 + 0,37 × NP
RVB60	68	2,7	480	18,9	538	21,2	123	4,8	28	1,1	10 + 2,35 × NP	0,39 + 0,09 × NP	2,8 + 0,219 × NP	6,17 + 0,48 × NP
RVC110	170	6,7	378	14,9	466	18,3	258	10,2	28	1,1	10 + 2,4 × NP	0,39 + 0,09 × NP	8,8 + 0,409 × NP	19,40 + 0,9 × NP
RVC170	170	6,7	600	23,6	688	27,1	258	10,2	28	1,1	10 + 2,4 × NP	0,39 + 0,09 × NP	11,5 + 0,617 × NP	25,35 + 1,36 × NP
RVM110	91	3,6	520	20,5	619	24,4	190	7,5	28	1,1	10 + 2,6 × NP	0,393 + 0,102 × NP	8,4 + 0,408 × NP	18,52 + 0,9 × NP
RVD235	204	8,0	682	26,9	788	31,0	310	12,2	28	1,1	13 + 2,5 × NP	0,51 + 0,10 × NP	40 + 0,828 × NP	88,18 + 1,83 × NP

CONDENSERS

RCA14	42	1,7	164	6,5	203	8,0	81	3,2	16	0,6	9 + 2,3 × NP	0,35 + 0,09 × NP	0,7 + 0,049 × NP	1,54 + 0,11 × NP
RCA22	42	1,7	260	10,2	299	11,8	81	3,2	16	0,6	9 + 2,3 × NP	0,35 + 0,09 × NP	0,9 + 0,073 × NP	1,98 + 0,16 × NP
RCA34	42	1,7	432	17,0	471	18,5	81	3,2	16	0,6	9 + 2,3 × NP	0,35 + 0,09 × NP	1,3 + 0,116 × NP	2,87 + 0,26 × NP
RCB31	68	2,7	232	9,1	286	11,3	123	4,8	28	1,1	10 + 2,35 × NP	0,35 + 0,09 × NP	1,7 + 0,114 × NP	3,75 + 0,25 × NP
RCB47	68	2,7	360	14,2	417	16,4	123	4,8	28	1,1	10 + 2,35 × NP	0,39 + 0,09 × NP	2,3 + 0,168 × NP	5,07 + 0,37 × NP
RCB60	68	2,7	480	18,9	538	21,2	123	4,8	28	1,1	10 + 2,35 × NP	0,39 + 0,09 × NP	2,8 + 0,219 × NP	6,17 + 0,48 × NP
RCC110	170	6,7	378	14,9	466	18,3	258	10,2	28	1,1	10 + 2,4 × NP	0,39 + 0,09 × NP	8,8 + 0,409 × NP	19,4 + 0,9 × NP
RCC170	170	6,7	600	23,6	688	27,1	258	10,2	28	1,1	10 + 2,4 × NP	0,39 + 0,09 × NP	11,5 + 0,617 × NP	25,35 + 1,36 × NP
RCM110	91	3,6	520	20,5	619	24,4	190	7,5	28	1,1	10 + 2,6 × NP	0,39 + 0,10 × NP	8,4 + 0,408 × NP	18,52 + 0,9 × NP
RCD235	204	8,0	682	26,9	788	31,0	310	12,2	28	1,1	13 + 2,5 × NP	0,51 + 0,10 × NP	40 + 0,828 × NP	88,18 + 1,83 × NP

SUBCOOLERS / ECONOMIZERS / DESUPERHEATERS

RSA14	42	1,7	164	6,5	203	8,0	81	3,2	16	0,6	9 + 2,3 × NP	0,35 + 0,09 × NP	0,7 + 0,049 × NP	1,54 + 0,11 × NP
RSA22	42	1,7	260	10,2	299	11,8	81	3,2	16	0,6	9 + 2,3 × NP	0,35 + 0,09 × NP	0,9 + 0,073 × NP	1,98 + 0,16 × NP
RSB31	68	2,7	232	9,1	286	11,3	123	4,8	28	1,1	10 + 2,35 × NP	0,39 + 0,09 × NP	1,7 + 0,114 × NP	3,75 + 0,25 × NP
RSB47	68	2,7	360	14,2	417	16,4	123	4,8	28	1,1	10 + 2,35 × NP	0,39 + 0,09 × NP	2,3 + 0,168 × NP	5,07 + 0,37 × NP

NP – number of plates | dim. F±/3%

All dimensions and technical data are approximate only and may be changed without further notice.

SafePLATE

DOUBLE WALL HEAT EXCHANGERS
DESIGNED FOR APPLICATIONS WHERE
IT IS CRUCIAL TO DOUBLE-PROTECT
MEDIA FROM MIXING AND QUICKLY
DETECT ANY POTENTIAL INTERNAL LEAK.

APPLICATION



TAP WATER
HEATING SYSTEMS



CENTRAL HEATING
SYSTEMS



TECHNOLOGICAL
SYSTEMS

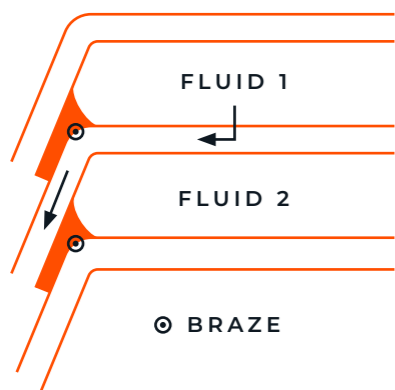

DOUBLE-WALL SYSTEM

In case of failure, either corrosion or pressure induced, special arrangement of double walls and interspace in sidewalls prevents fluids from mixing and allow visual detection of a leakage.

ADVANTAGES



EFFECTIVE LEAK DETECTION



HELPS TO PREVENT POTENTIAL
MIXING OF WORKING MEDIA

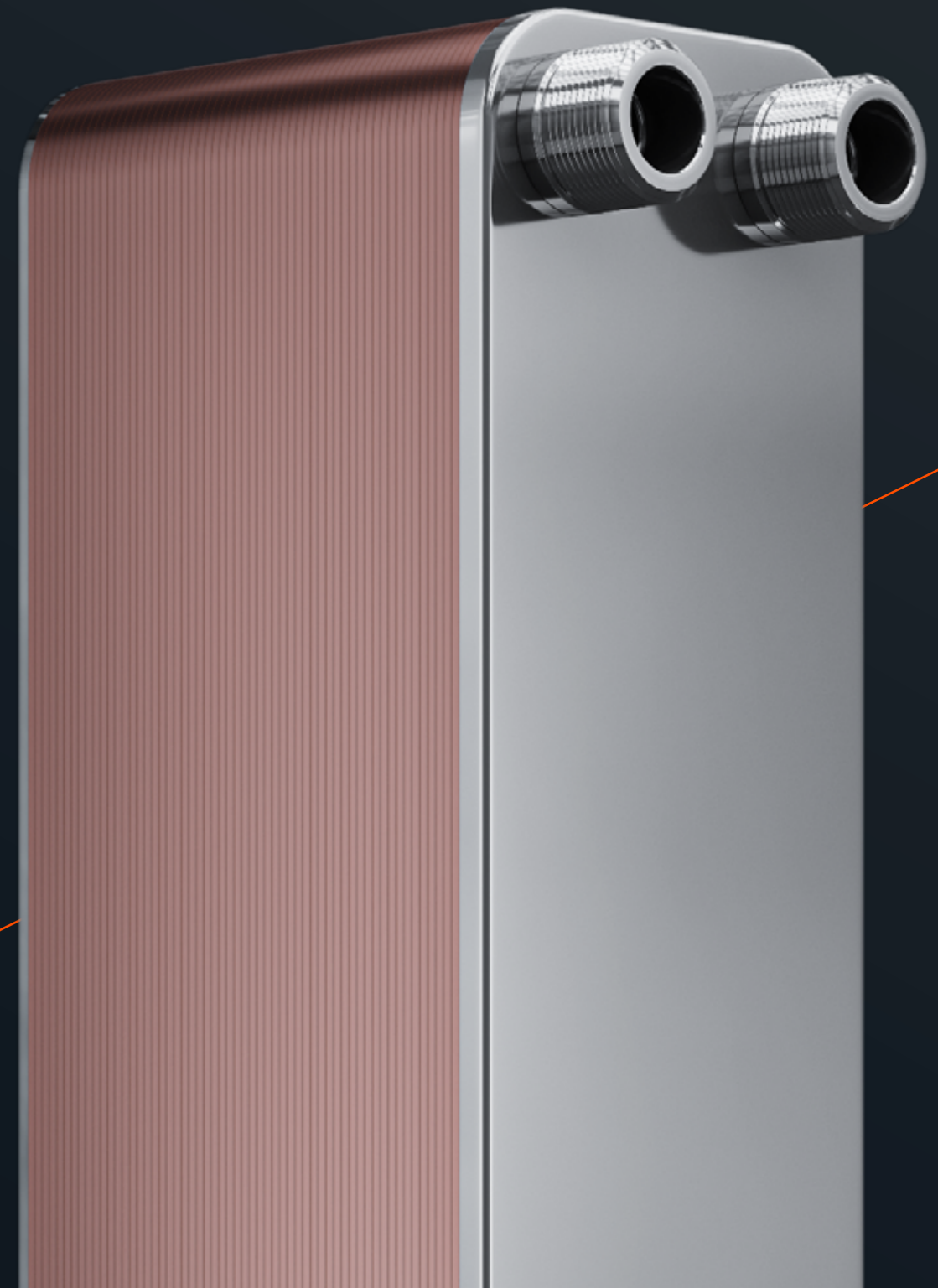

EXEMPLAR DESIGNATION

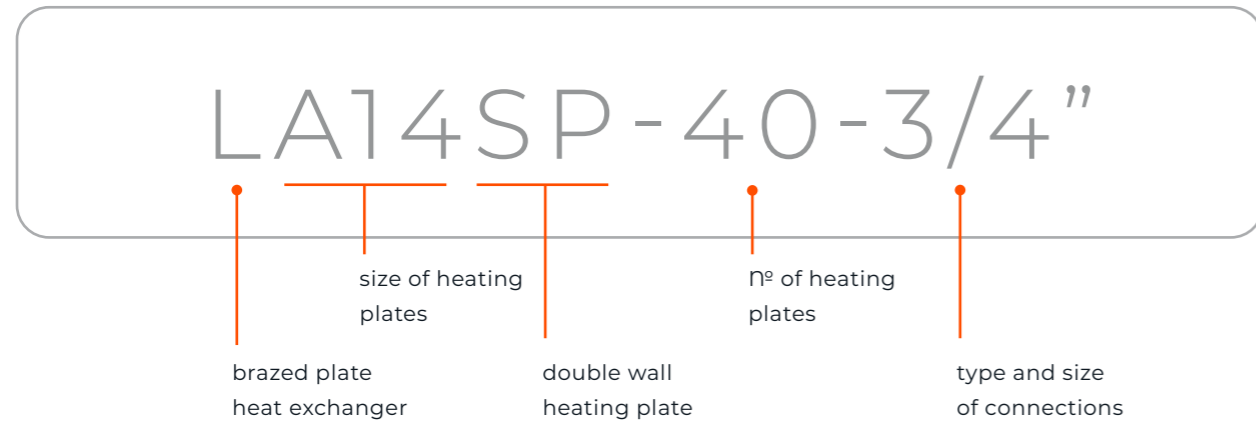

PRODUCT LINE



TECHNICAL DATA

MATERIALS

- STAINLESS STEEL
- COPPER BRAZING

EXEMPLARY MEDIA

- WATER
- PROPYLENE GLYCOL SOLUTIONS
- GROUP II FLUIDS
- OTHER (CONSULT THE MANUFACTURER)

WORKING PARAMETERS

MAX. TEMPERATURE — 230°C / 446°F

MIN. TEMPERATURE — -195°C / -319°F

MAX. PRESSURE

LA SP, LB SP — 3 MPA / 435 PSI
 LC SP — 2 MPA / 290 PSI

STANDARD LOCATION OF CONNECTIONS

K1 / K4 — inlet / outlet hot side K1 / K4 — inlet / outlet hot side

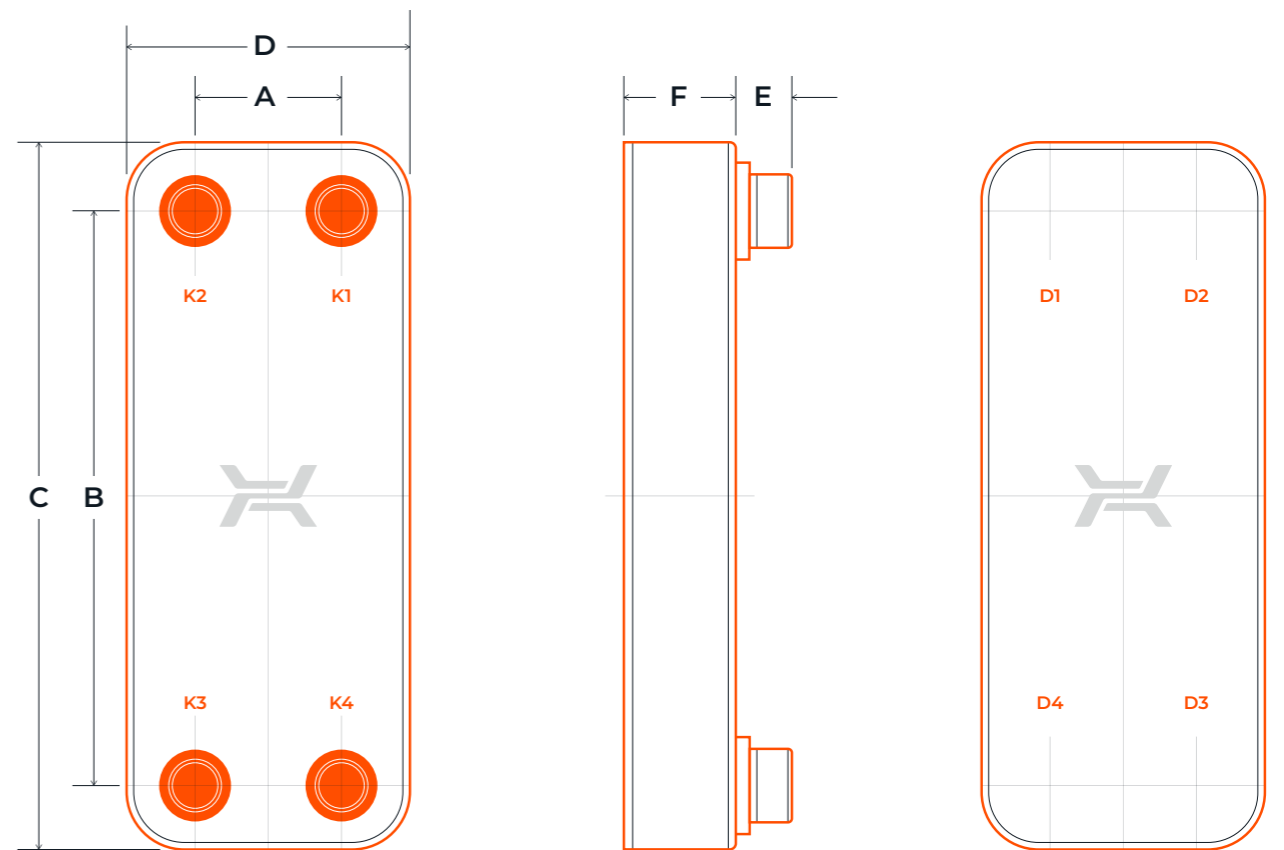

Double-wall heat exchangers have been designed to prevent media from mixing and enable quick leak detection. However, it should be remembered that no heat exchangers of this type guarantee the reliability of such operation and cannot be used instead of other safety systems.

TECHNICAL PARAMETERS

Type	Dimensions										max № of plates	Mass			
	A		B		C		D		E			F		kg	lb
	mm	in	mm	in	mm	in	mm	in	mm	in	mm	in			
LA14SP	42	1.7	164	6.5	203	8.0	81	3.2	16	0.6	9 + 2,5 × NP	0.35 + 0.1 × NP	40	0,6 + 0,064 × NP	1.32 + 0.14 × NP
LB31SP	68	2.7	232	9.1	286	11.3	123	4.8	28	1.1	10 + 2,5 × NP	0.39 + 0.1 × NP	100	1,6 + 0,114 × NP	3.53 + 0.25 × NP
LB60SP	68	2.7	480	18.9	538	21.2	123	4.8	28	1.1	10 + 2,5 × NP	0.39 + 0.1 × NP	100	2,6 + 0,247 × NP	5.73 + 0.54 × NP
LC110SP	170	6.7	378	14.9	466	18.3	258	10.2	28	1.1	11 + 2,5 × NP	0.43 + 0.1 × NP	150	8,7 + 0,777 × NP	19.18 + 1.71 × NP

NP – number of plates | dim. F+/-3%

All dimensions and technical data are approximate only and may be changed without further notice.

FLOW ARRANGEMENT



ONE-PASS



Channels are parallel.

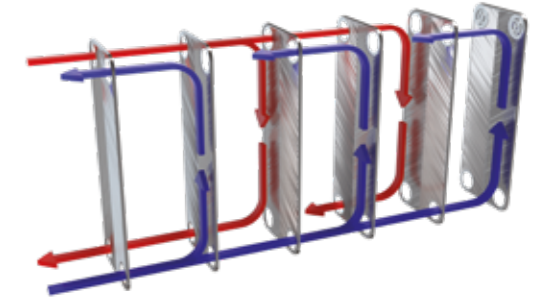

TWO-PASS
WITH 4 CONNECTIONS



Plates divided into two groups which are connected in series.

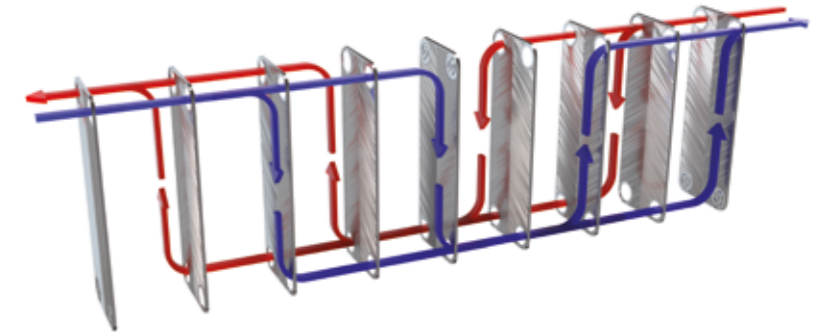

TWO-PASS
WITH 6 CONNECTIONS



Plates divided into two groups which are connected in series.

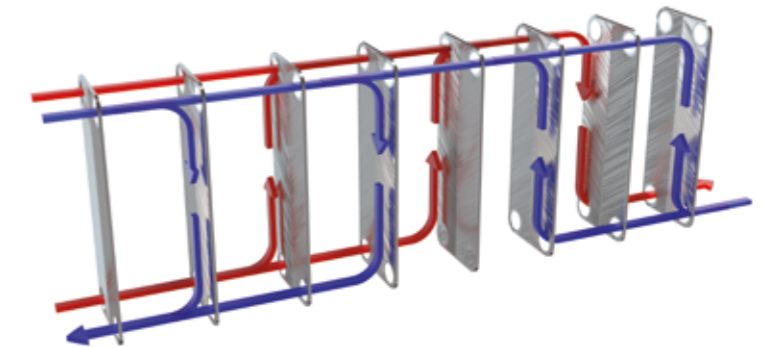

TYPE AND SIZE OF CONNECTIONS

Safe PLATE	Luna	R	L	Connections													
				3/8"	1/2"	3/4"	1"	1 1/4"	1 1/2"	2"	2 1/2"	DN50	DN80	DN100			
				LA12	⊙⊙	⊙⊙	⊙⊙										
LA14SP	LA14LN	RVA14	RCA14	LA14	⊙⊙⊙	⊙⊙⊙	⊙⊙⊙										
	LA22LN	RVA22	RCA22	LA22	⊙⊙⊙	⊙⊙⊙	⊙⊙⊙										
	LA34LN	RVA34	RCA34	LA34	⊙⊙⊙	⊙⊙⊙	⊙⊙⊙										
				LJ30			⊙⊙	⊙									
				LH40			⊙⊙	⊙									
LB31SP	LB31LN	RVB31	RCB31	LB31			⊙⊙⊙Δ	⊙⊙⊙Δ	⊙⊙⊙Δ	Δ							
	LB47LN	RVB47	RCB47	LB47			⊙⊙⊙Δ	⊙⊙⊙Δ	⊙⊙⊙Δ	Δ							
LB60SP	LB60LN	RVB60	RCB60	LB60			⊙⊙⊙Δ	⊙⊙⊙Δ	⊙⊙⊙Δ	Δ							
	LM110LN	RVM110	RCM110	LM110							⊙⊙						
LC110SP	LC110LN	RVC110	RCC110	LC110			⊙⊙	⊙⊙⊙Δ	⊙⊙⊙Δ	⊙⊙Δ	⊙⊙Δ	⊙⊙Δ	⊙⊙Δ	⊙⊙Δ	⊙⊙Δ	⊙⊙Δ	⊙⊙Δ
	LC170LN	RVC170	RCC170	LC170			⊙⊙	⊙⊙⊙Δ	⊙⊙⊙Δ	⊙⊙Δ	⊙⊙Δ	⊙⊙Δ	⊙⊙Δ	⊙⊙Δ	⊙⊙Δ	⊙⊙Δ	⊙⊙Δ
	LD235LN	RVD235	RCD235	LD235												⊙⊙	
				LE400													⊙⊙

- ⊙ internal thread
- ⊙ dual (external thread flange and soldering)
- Δ Victaulic
- ⊙⊙ flange
- ⊙ welded connection for R heat exchangers

MOUNTING BRACKETS

MOUNTING BRACKETS ARE MANUFACTURED USING STAINLESS STEEL OR CARBON ZINC-PLATED STEEL



INSULATION

INSULATION MADE OF POLYURETHANE FOAM COVERED WITH ALUMINUM (APFI)

- MAX. WORKING TEMPERATURE: 135°C / 275°F
- THICKNESS: 30 MM / 1.18 IN
- THERMAL CONDUCTIVITY: 0,026 W/MK / 0.015 BTU/FT. HOUR°F



INSULATION MADE OF EXPANDED POLYPROPYLENE (EPPI) WITH ALUMINUM (APFI)

- MAX. WORKING TEMPERATURE: 110°C / 230°F
- THICKNESS: 28 MM / 1.10 IN
- THERMAL CONDUCTIVITY: 0,035 W/MK / 0.020 BTU/FT. HOUR°F



COLD INSULATION FOR R-LINE HEAT EXCHANGERS

- WORKING TEMPERATURE RANGE: -40°C TO 110°C / -40°F TO 230°F
- THICKNESS: 20 MM / 0.787 IN
- THERMAL CONDUCTIVITY: 0,037 W/MK / 0.021 BTU/FT. HOUR°F



hexonic.com

alnab

EN.ver.1.2022

Alnab Armatur AB
Ögärdesvägen 4B
SE-433 30 Partille

Websida: www.alnab.se
Tel: +46(0)31-449450

ver 1 2022