

Ball-float steam trap

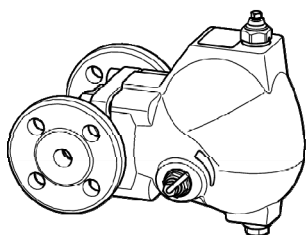

UNA 45

UNA 46

UNA 46A

UNA 47

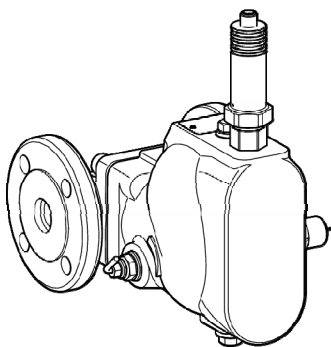
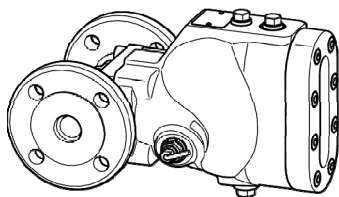

Contents

Foreword	3
Availability	3
Formatting features in the document	3
Safety	3
Use for the intended purpose	3
Basic safety notes	4
Information on property damage or malfunctions	4
Qualification of personnel	5
Protective gear	5
Typographic features of warning notes	5
Formatting features for warnings of property damage	5
Description	6
Scope of supply and equipment specification	6
Task and function	10
Storing and transporting the equipment	11
Storing the equipment	11
Transporting the equipment	11
Mounting and connecting the equipment	12
Preparing installation	12
Orientation of the equipment	12
Connecting the equipment	13
Operation	16
After operation	17
Removing external dirt deposits	18
Maintaining the equipment	18
Servicing the equipment and installing spare parts	23
Troubleshooting	32
Putting the equipment out of operation	34
Removing harmful substances	34
Removing the equipment	34
Re-using equipment after storage	35
Disposing of the equipment	36
Technical data	37
Dimensions and weights	37
Pressure & temperature ratings	48
Manufacturer's declaration	49

Foreword

This installation & operating manual will help you use the following types of equipment safely and efficiently for their intended purpose.

- ▶ UNA 45
- ▶ UNA 46
- ▶ UNA 46A
- ▶ UNA 47

These steam traps will be called equipment in this document.

This installation & operating manual is intended for anyone commissioning, using, operating, servicing, cleaning or disposing of this equipment and, in particular, for professional after-sales service technicians, qualified personnel and authorised and trained staff.

All of these persons must read and understand the content of this installation & operating manual.

Following the instructions given in this installation & operating manual helps avoiding danger and increases the reliability and service life of the equipment. Please note that in addition to the instructions given in this installation & operating manual you must also observe all locally applicable rules and regulations concerning the prevention of accidents as well as approved safety guidelines for good professional practice.

Availability

Keep this installation & operating manual together with the plant documentation for future reference. Make sure that this installation & operating manual is available to the operator.

The installation & operating manual is part of the equipment. Please hand over this installation & operating manual when selling the equipment or passing it on.

Formatting features in the document

Certain text elements of this installation & operating manual feature a specific typographic design. You can easily distinguish the following text elements:

Standard text

Cross-reference

- ▶ Listing
 - ▶ Sub-items in listings
- Steps for action.



Here you will find additional useful information and tips serving to assist you in using the equipment to its fullest potential.

Safety

Use for the intended purpose

The following ball float steam traps are designed to discharge condensate from steam systems:

- ▶ UNA 45
- ▶ UNA 46
- ▶ UNA 46A
- ▶ UNA 47

Type UNA 45 models can also be used to discharge condensate from compressed air.

Type UNA 46, UNA 46A and UNA 47 models can also be used to discharge condensate from other gases or gas mixtures.

The equipment must only be used within the allowable pressure and temperature limits and only if the chemical and corrosive influences on the equipment are taken into account.

On type UNA 45, UNA 46 and UNA 46A models with DUPLEX control unit and control membrane, the superheated steam on the control membrane must not exceed 5 K.

Correct use includes compliance with the instructions given in this installation & operating manual, in particular obedience to all safety instructions.

Any other use of the equipment is considered to be improper.

Note that the equipment is also used incorrectly if the materials of the equipment are not suitable for the fluid.

Basic safety notes

Risk of severe injuries

- ▶ The equipment is under pressure during operation and may be hot. Before carrying out any work on the equipment make sure that the following requirements are met:
 - ▶ The pipes must be depressurized (0 bar).
 - ▶ The fluid must be completely removed from the pipes and the equipment.
 - ▶ During work on the equipment the installation must be switched off and protected against unauthorised or unintended activation.
 - ▶ The pipes and the equipment must have cooled down to room temperature (approx. 20 °C).
- ▶ If the equipment is used in contaminated areas there is a risk of severe injuries or death caused by harmful substances in or on the equipment. Before working on the equipment make sure that it is completely decontaminated. Always wear the protective clothing prescribed for contaminated areas when working on the equipment.
- ▶ The equipment must only be used with fluids that do not attack the material and the gaskets and sealings of the equipment. Otherwise leaks may occur and hot or toxic fluid could escape.
- ▶ The equipment and its component parts must only be mounted or removed by qualified

personnel. A qualified person must be acquainted with and experienced in the following:

- ▶ Making pipe connections.
- ▶ Selecting suitable lifting gear and understanding the rules for its safe use.
- ▶ Working with dangerous (contaminated, hot or pressurized) fluids.
- ▶ If the admissible temperature and pressure limits are exceeded the equipment may be destroyed and hot or pressurized fluid may escape. Make sure that the equipment is only operated within the admissible service range and limits.

For more information on limits and pressure & temperature ratings see name plate and the section "*Technical Data*".

Risk of minor injuries

- ▶ Sharp edges on internals present the danger of cuts to hands. Always wear industrial gloves when servicing the equipment.
- ▶ If the support of the equipment during installation is insufficient the equipment might fall down, thereby causing bruises or injuries. Make sure the equipment is safely held in place during installation and cannot fall down. Wear protective safety footwear.

Information on property damage or malfunctions

- ▶ Malfunctions will occur if the equipment is installed in a wrong position or with the flow arrow pointing in the opposite direction of the fluid flow. This may result in damage to the equipment or the installation. Make sure that the flow arrow on the equipment body matches the indicated direction of the fluid flow in the pipe.
- ▶ If the material is unsuitable for the fluid, increased wear may occur and fluid may escape. Make sure that the material is suitable for the fluid used in your installation.

Qualification of personnel

A qualified person must be acquainted with and experienced in the following:

- ▶ the pertinent on-site rules and regulations for preventing fire and explosions as well as industrial safety regulations
- ▶ working on pressure equipment
- ▶ making pipe connections
- ▶ working with dangerous (hot or pressurized) fluids
- ▶ lifting and transporting loads
- ▶ observing all notes and instructions in this installation & operating manual and the applicable documents

Protective gear

The operator must ensure that anyone working on the equipment must wear the required protective clothing and safety gear stipulated for the site of installation. The protective clothing must be suitable for the used media and must protect the wearer against safety and health hazards associated with a particular job to be carried out at the site of installation. Protective clothing & equipment must provide protection from potential hazards, in particular from injuries to:

- ▶ Head
- ▶ Eyes
- ▶ Body
- ▶ Hand
- ▶ Feet
- ▶ Hearing

Note that this list is not exhaustive. The operator must establish personal protective equipment guidelines and specify any additional protective gear that is required if the worker is exposed to a specific risk at the site of installation.

Typographic features of warning notes



DANGER

Notes with the heading DANGER warn against imminent dangerous situations that can lead to death or serious injuries.



WARNING

Notes with the heading WARNING warn against possibly dangerous situations that could lead to death or serious injuries.



CAUTION

Notes with the heading CAUTION warn against dangerous situations that could lead to minor or moderate injuries.

Formatting features for warnings of property damage

Attention!

This information warns of a situation leading to property damage.

Description

Scope of supply and equipment specification

Scope of supply

Our equipment is delivered packed and ready for assembly.

Equipment specification

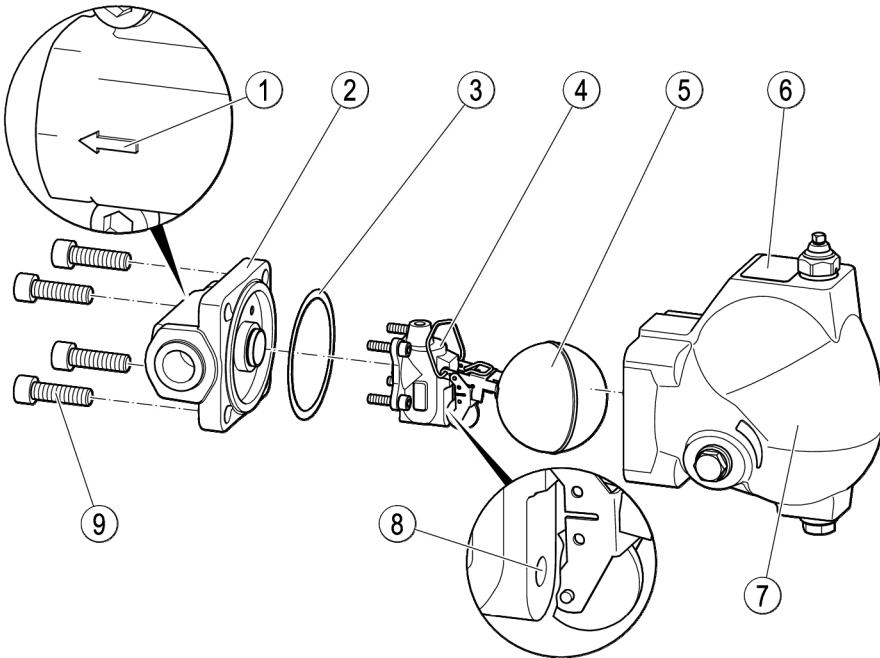

Item no.	Designation
1	Direction of flow arrow
2	Body
3	Body gasket
4	Control unit (shown here: control unit SIMPLEX)
5	Float

Item no.	Designation
6	Name plate
7	Cover (shown here: standard cover)
8	Orifice
9	Screws (4 pcs.)

Optional extras

The following items are available as optional extra:

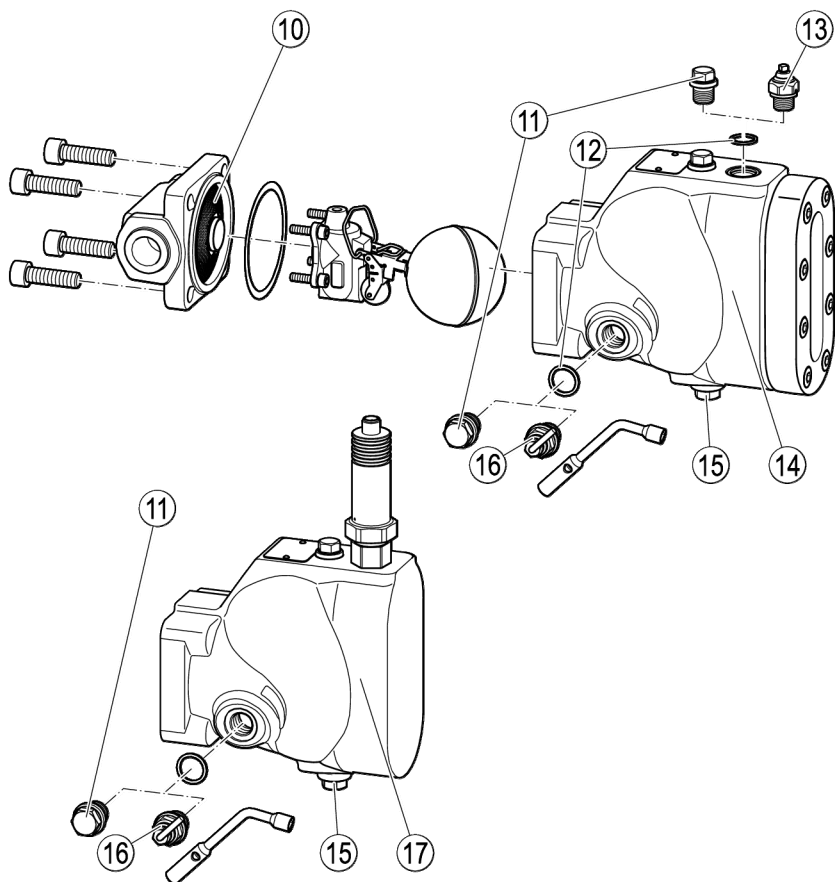

No.	Designation
10	Strainer ¹
11	Sealing plug
12	Sealing ring
13	Manual vent valve with socket wrench (socket wrench not shown) The hole in the cover for the manual vent valve can also be used to connect a balance pipe.

No.	Designation
14	Sightglass with water-level gauge for function check ¹
15	Drain with sealing plug
16	Manual lifting lever with socket wrench
17	Electrode cover with connection options for electrodes NRG 16-19 or NRG 16-27 ¹

1 Not for UNA 47, PN63

The equipment can be fitted optionally with the following control units:

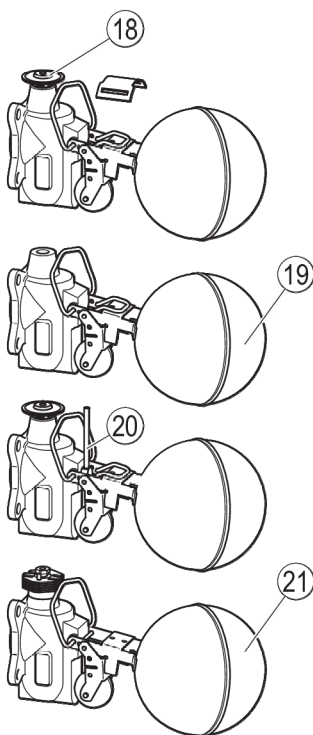

No.	Designation
18	DUPLEX control unit with control membrane
19	SIMPLEX-P control unit with Perbunan® roller ball
20	Control unit with externally adjustable internal bypass
21	DUPLEX control unit with bimetallic vent (UNA 47)

The different equipment versions allow you to adjust the flow direction of the equipment to the flow pattern of your installation. The flow arrow must correspond to the direction of the fluid flow. The following positions of installation are possible:

- ▶ "v" for installation in vertical pipework with downward flow
- ▶ "hl" for flow from right to left (when viewed from the body end)
- ▶ "hr" for flow from left to right (when viewed from the body end)

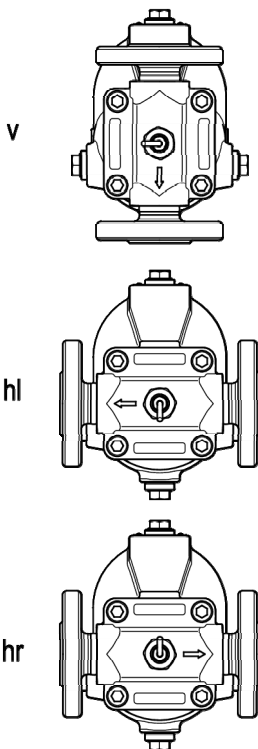

End connections

The equipment is available with the following end connections:

- ▶ Flanges
 - ▶ Screwed sockets
- (Not for UNA 47)
- ▶ Socket-weld ends
 - ▶ Butt-weld ends via transition pieces

Name plate

The following items are indicated on the name plate:

- ▶ Manufacturer
- ▶ Type designation
- ▶ Design
- ▶ Nominal size
- ▶ Pressure rating
- ▶ Design temperature
- ▶ Design pressure
- ▶ Max. service temperature
- ▶ Max. admissible differential pressure
- ▶ CE marking
- ▶ Date of manufacturing
- ▶ Material number

The following items are indicated on the equipment body:

- ▶ Material
- ▶ Batch code
- ▶ Direction of flow

The following items are indicated on the end connections:

- ▶ Flange size
- ▶ Flange face type (RJ number)
- ▶ Thread type



The limiting conditions and pressure & temperature ratings specified in this installation manual are applicable for standard equipment. Note that these values may differ for modified or customized equipment.

All equipment specific values are indicated on the nameplate.

Application of European Directives

Pressure Equipment Directive

The equipment conforms to this directive (see "Manufacturer's Declaration" section) and can be used for the following media:

UNA 45

- ▶ Fluids of group 2

UNA 46 and UNA 46A

- ▶ Fluids of group 1
- ▶ Fluids of group 2

UNA 47

- ▶ Fluids of group 1
- ▶ Fluids of group 2

ATEX Directive

The equipment does not have its own potential ignition source and is not subject to this directive (see "Manufacturer's Declaration" section).

When installed, static electricity may arise between the equipment and the connected system.

When used in potentially explosive atmospheres, the plant manufacturer or plant operator is responsible for discharging or preventing possible static charge.

If it is possible for medium to escape, e.g. through actuating mechanisms or leaks in threaded joints, the plant manufacturer or plant operator must take this into consideration when dividing the area into zones.

Task and function

Purpose

Type UNA 45, UNA 46, UNA 46A and UNA 47 models are used to discharge condensate from water vapour on steam-heated consumers.

Type UNA 45 models can also be used to discharge condensate from compressed air.

Type UNA 46, UNA 46A and UNA 47 models can also be used to discharge condensate from other gases or gas mixtures.

Function

A float ball opens the orifice based on the fill level. This regulates the drainage rate. With the orifice opened to maximum, the drainage rate depends on the diameter of the orifice.

Models with SIMPLEX control unit are particularly suited to cold condensates and superheated steam.

Models with SIMPLEX-P control unit are controlled by the float with rolling ball regulator. The Perbunan® roller ball ensures a good seal at the seat. Models with this control unit are particularly suited to cold condensates and cold distillates.

Models with DUPLEX control unit also vent the system. The DUPLEX control unit consists of the float with rolling ball regulator and an additional, temperature-dependent bimetallic vent. Venting on UNA 45, UNA 46 and UNA 46A occurs via the control membrane, and via bimetallic vent on UNA 47. Models with this control unit are particularly well suited to saturated steam systems. On UNA 45, UNA 46 and UNA 46A devices with DUPLEX control unit and control membrane, the superheated steam at the control membrane must not exceed 5 K.

You can lift the float manually using the optional manual lifting lever.

The optional manual vent valve allows you to vent the pipe manually.

The externally adjustable internal bypass is used to set a bypass flow. This is routed inside the device past the control unit.

Storing and transporting the equipment

Attention!

Equipment can be damaged if stored or transported improperly.

- Close all openings with the sealing plugs or covers supplied with the equipment or use similar sealing covers.
- Protect the equipment against moisture and corrosive atmospheres.
- Please contact the manufacturer if the specified transport and/or storage requirements cannot be met.

Storing the equipment

- Please observe the following items when storing the equipment:
 - ▶ Do not store the equipment for more than 12 months.
 - ▶ Use the supplied sealing plugs or other suitable seal caps in order to seal off all openings of the equipment.
 - ▶ Protect the sealing surfaces and contact areas against mechanical damage.
 - ▶ Protect the equipment and all components against hard shocks and impacts.
 - ▶ Store the equipment only in closed rooms that meet the following environmental conditions:
 - ▶ Air humidity below 50 %, not condensing
 - ▶ Indoor air: clean, salt-free and non-corrosive
 - ▶ Temperature 5–40 °C.
- Make sure that all these requirements are always met when storing the equipment.
- Please contact the manufacturer if you cannot comply with the recommended storage conditions.

Transporting the equipment



CAUTION

Do not drop the equipment. If it falls down it may cause bruises and injuries.

- To transport and mount the equipment safely use suitable lifting gear.
- Connect the noose strap of the lifting gear to the body.
- Provide sufficient support for the equipment during transport and installation.
- Wear protective safety footwear.

Lightweight equipment may be transported and mounted without using any lifting gear.

To lift equipment the weight of which exceeds approx. 25 kg, you need the help of a second person or suitable lifting gear.

Your physical strength and on-site regulations and conditions determine what weight can be lifted and if support is required.

- Meet the requirements for storage also when transporting the equipment.
- Prior to transport seal off connections with sealing plugs.



If you do not have the sealing plugs supplied with the equipment use appropriate seal caps to seal off the connections.

- For short distances (only a few metres) you can transport the equipment unpacked.
- When transporting the equipment over larger distances use the original packaging.
- If you do not have the original packaging use a box that protects the equipment adequately against corrosion and physical damage.



For a short period of time the equipment may be transported even if the temperature is below 0 °C, provided that the equipment is completely empty and dry.

Mounting and connecting the equipment

Preparing installation

- Take the equipment out of the transport packaging.
- Check the equipment for transport damage.
- Contact the manufacturer if you detect any kind of shipping damage.

When supplied by the factory, the connections may be sealed off with sealing plugs.

- Remove sealing plugs before mounting the equipment.
- Keep the sealing plugs and the packing for further use.



DANGER

Personnel working on pipes are exposed to safety risks and may suffer severe injuries, poisoning or even loss of life.

- Make sure that no hot or hazardous fluid is in the equipment or the pipes.
- Make sure that the pipes upstream and downstream of the equipment are depressurised.
- Make sure that the installation is switched off and protected against unauthorised or unintended activation.
- Make sure that the equipment and the pipes have cooled down to room temperatures.
- Wear protective clothing that is suitable for the fluid and, if necessary, wear protective gear.

For more information on suitable protective clothing and safety gear refer to the safety data sheet of the fluid in question.

- Drain pipes until they are empty.
- Switch the installation off and protect it against unauthorised or unintended re-activation.

Orientation of the equipment

The different equipment versions allow you to adjust the flow direction of the equipment to the flow pattern of your installation. The following positions of installation are possible:

- with horizontal connections "hl" and "hr" for installation in horizontal pipes
- with vertical connections "v" for installation in vertical pipework with downward flow

Attention!

Malfunctions may occur if the control unit is installed incorrectly.

- When installing the equipment make sure that the name plate on the cover is on top and the float arm is free to move up and down.

To avoid malfunctions make sure the following requirements are met when mounting the equipment:

- The flow arrow on the equipment body must match the fluid flow direction.
- The name plate on the cover must point upwards.
- Contact the manufacturer if you want to mount the equipment in a different position of installation.
- Remove the cover from the body as described in the section "*Removing cover*" from page 19.
- Remove the control unit as described in the section "*Removing control unit*" on page 19.
- Turn the control unit by 90° or 180° into the desired position of installation.
- Make sure that the float arm is free to move up and down.
- Secure the control unit to the body as described in the section "*Mounting the control unit*" from page 20.
- Attach the cover to the body as described in the section "*Mounting cover*" from page 21.

Connecting the equipment



DANGER

Incorrectly connected equipment can result in accidents with extremely severe injuries or death.

- Make sure that only specialist personnel connect the equipment to the pipe.
- Make sure that the direction of flow in the pipe matches the flow direction arrow on the equipment.
- Make sure that the connected pipe does not subject the body to any stress (forces or torques) during installation and operation.

Specialist personnel must have knowledge and experience of the type of pipe connection used.



CAUTION

Do not drop the equipment. If it falls down it may cause bruises and injuries.

- To transport and mount the equipment safely use suitable lifting gear.
- Connect the noose strap of the lifting gear to the body.
- Provide sufficient support for the equipment during transport and installation.
- Wear protective safety footwear.

Lightweight equipment may be transported and mounted without using any lifting gear.

To lift equipment the weight of which exceeds approx. 25 kg, you need the help of a second person or suitable lifting gear.

Your physical strength and on-site regulations and conditions determine what weight can be lifted and if support is required.

Attention!

Equipment will be damaged if the end connections are undersized.

- Make sure that the connections are strong and rigid enough to support the weight of the equipment and to withstand the forces that occur during operation.

Consider space required for servicing the equipment and/or exchanging components and observe the necessary withdrawal distance to remove the cover. For more information on the required withdrawal distances see section "*Dimensions and weights*" on page 37.

- Make sure that the pipe system of the plant is clean.
- Make sure that the equipment is free from foreign matter.
- Install the equipment in the desired, permitted installation position.
- Make sure that the pipes meet the following requirements:
 - The layout of the pipelines must prevent the formation of water pockets.
 - The pipeline must have a gradient so that the condensate is free to fall towards the equipment
 - The cross section of the air balance pipe must be at least DN 8 (1/4 ") .
 - If the equipment is fitted with control unit SIMPLEX, an air balance pipe must be connected to the vent hole for the hand-vent valve. The air balance pipe must have the following end connection dimensions:
 - Standard cover and sightglass cover: G3/8 "
 - Cover with electrode connections: G1/4 "

- If one or more of the above mentioned requirements cannot be met, please contact our Technical Service or authorized agency in your country.
- Connect the end connections of the equipment properly to the pipes.
- If necessary, connect the air balance pipe to the equipment as shown in the following drawing.

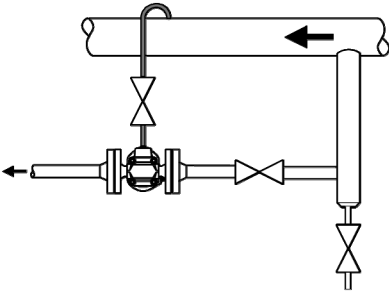

- Make sure that the equipment is safely mounted and that all connections are made correctly.

Mounting the measuring electrode

If using models with electrode cover, you can fit one or two measurement electrodes of the following types to the device:

- ▶ NRG16–19 or NRG16–27 on the top of the body (23) for measuring the banking-up of condensate
- ▶ NRG16–19 or NRG16–27 on the side of the body (25) for measuring the loss of condensate



Fitting the NRG16–27 on the top of the body on models with DN15–DN25 requires an adapter (22) with sealing ring. The adapter with sealing ring can be purchased from the manufacturer using the stock code 556841.

For models with standard cover, you can attach a measurement electrode to the side.

The following tools are required for assembly:

- ▶ Size 22, 24, 27 and 32 open-ended spanner, DIN 3113, form B
- ▶ Torque wrench 60–120 Nm to DIN ISO 6789

Attention!

Incorrect installation may cause damage to the measurement electrode.

- ▶ Make sure that the device is not insulated after installing a measurement electrode.
- ▶ Read and follow the instructions in the measurement electrode operating instructions.

Fit the measurement electrodes as follows:

- ▶ Lubricate the thread and head of the measurement electrode with temperature-resistant lubricant.

The lubricant must have the same properties as OKS®217.

If you wish to fit a NRG16–27 measurement electrode with adapter (22) in the top connection, you must proceed as follows:

- ▶ Place the sealing ring of the adapter onto the adapter.
- ▶ Screw the adapter (22) with sealing ring into the top connection.
- ▶ Tighten the adapter to a torque of 75 Nm.

The remaining steps are identical for both fitting types and connections:

- ▶ Screw the measurement electrode into the connections on the body illustrated below using a suitable open-ended spanner.
- ▶ Tighten the measurement electrode to a torque of 75 Nm.
- ▶ Connect the device to the pipe as described in the previous section.
- ▶ Connect a balance pipe to connection G $\frac{1}{4}$ " (24).

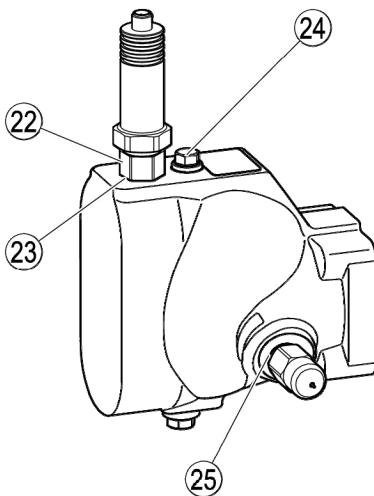

Before mounting measuring electrodes please note:

If a measuring electrode type NRG 16–27 is mounted on top of the body, only a screwed union for a pipe with cross section 8 mm will fit into the bore G $\frac{1}{4}$ ". If a screwed union for a pipe with cross section 10 mm were used, the hexagon connection would press onto the measuring electrode.

Operation

During operation you can undertake the following work:

- ▶ Open and close the optional hand-vent valve
- ▶ Open and close the optional manual float-lifting lever
- ▶ Adjust the optional bypass

To do this, use the socket spanner (stock code # 526110) supplied with the equipment.

The optional hand vent valve allows manual air venting.

- To air vent the equipment turn the hand-vent valve (viewed from top) anticlockwise.
- To close the hand-vent valve after air-venting turn it clockwise.
- Fasten the hand-vent valve hand tight.

The optional float-lifting lever allows the float to be manually lifted irrespective of the liquid level. It can be used to purge any dirt away from the seat area and out of the equipment by opening the orifice and draining the liquid.

The cast arrow on the body indicates the correct direction of rotation.

- ▶ To open the orifice turn the socket spanner from the tip of the arrow towards the end of the arrow.
- ▶ To close the orifice turn the socket spanner from the end of the arrow towards the tip of the arrow.

The optional bypass can be used to adjust the bypass flow using the socket wrench provided (26).

Attention!

Tightening the bypass too tightly may damage the device.

- Only tighten the bypass hand tight.
- To reduce the flow, turn the socket wrench clockwise.
- To increase the flow, turn the socket wrench anti-clockwise.

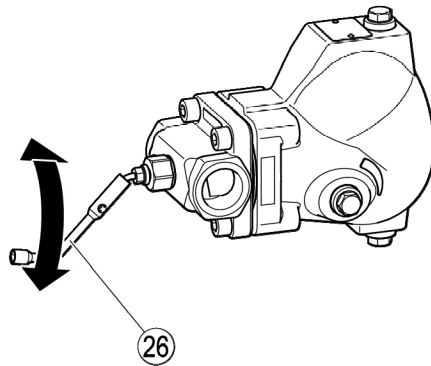

You can check the correct functioning of the equipment during operation using the GESTRA ultrasonic measuring unit VAPOPHONE® or TRAPTTEST® (VKP 40 and VKP 40plus).

- For more details refer to the installation & operating manual of the ultrasonic measuring unit.

After operation



DANGER

If fluid escapes personnel may suffer severe injuries, poisoning or even loss of life.

- After working on the equipment make sure that all connections and valves are tight.
- Make sure that the gaskets of the body are leakproof.



DANGER

Personnel working on pipes are exposed to safety risks and may suffer severe injuries, poisoning or even loss of life.

- Make sure that no hot or hazardous fluid is in the equipment or the pipes.
- Make sure that the pipes upstream and downstream of the equipment are depressurised.
- Make sure that the installation is switched off and protected against unauthorised or unintended activation.
- Make sure that the equipment and the pipes have cooled down to room temperatures.
- Wear protective clothing that is suitable for the fluid and, if necessary, wear protective gear.

For more information on suitable protective clothing and safety gear refer to the safety data sheet of the fluid in question.



DANGER

If the equipment is used in contaminated areas there is a risk of severe injuries or death caused by harmful substances in or on the equipment.

- Only qualified personnel are allowed to perform work on contaminated equipment.
- Always wear the protective clothing prescribed for contaminated areas when working on the equipment.
- Make sure that the equipment is completely decontaminated before carrying out any service work.
- Follow the pertinent instructions for handling the hazardous substances in question.

Attention!

Frost damage may occur when the installation is shut down.

- Drain the equipment if ambient temperatures below 0 °C (frost) are to be expected.
-

- Provide a device that collects any fluid that may escape.
- Remove the sealing plug (15) at the bottom of the body.
- Allow all liquid to escape and wait until the body is completely empty.
- To seal the drain hole screw in the sealing plug and tighten it with a torque of 75 Nm.

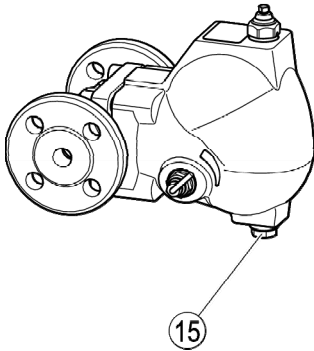

Removing external dirt deposits

- To remove dirt deposits rinse the equipment with fresh water and wipe it with a clean, lint-free cloth.
- To remove any persistent residues use a cleaning agent that is suitable for the material and carefully wipe the equipment with a clean, lint-free cloth.

Maintaining the equipment

For work on the equipment you will need the following tools:

- ◆ Combination spanner form B to DIN 3113, sizes
 - ◆ A. F. 17 mm
 - ◆ A. F. 22 mm
 - ◆ A. F. 24 mm
 - ◆ A. F. 32 mm
- ◆ Torque spanner to DIN ISO 6789
 - ◆ up to 10 Nm
 - ◆ 10 – 60 Nm
 - ◆ 60 – 120 Nm
 - ◆ 120 – 300 Nm
- ◆ Allen key to DIN ISO 2936, sizes
 - ◆ A. F. 4 mm
 - ◆ A. F. 6 mm
 - ◆ A. F. 8 mm
- ◆ Screwdriver 5.5/125 to DIN 5265



Malfunctions may occur if the equipment is used with different types of condensate: The following condensates in particular cause problems:

- very oily condensates
- condensates that resinify or become gummy
- condensates that recrystallize
- condensates that contain solid matter.

In these cases check the equipment at regular intervals for contamination and, if necessary, remove dirt deposits.

To reduce contamination we recommend installing a sedimentation vessel or a dirt pocket arrangement upstream of the equipment.

Normally you do not have to clean the internal parts of the equipment.

To clean the equipment completely take off the cover and remove the control unit.



The following drawings show equipment type UNA 4 with standard cover.

Removing cover



Remove the measuring electrode(s) if mounted, before lifting off the cover.

- Use a combination spanner A. F. 32 to DIN 3113, form B, to remove the measuring electrode.
- Remove the four screws (9) in the body.
- Lift the cover (7) off the body (2).
- Remove the body gasket (3).
- For the disposal of the body gasket observe the pertinent on-site regulations concerning waste disposal.

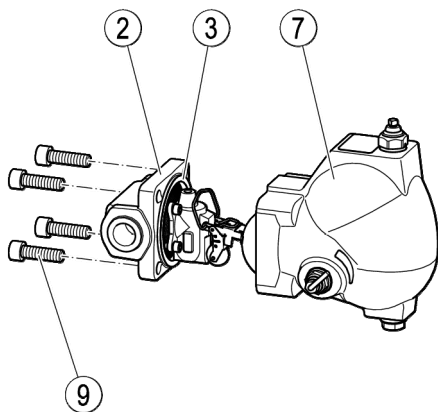

Removing control unit

- Remove the cover from the body as described in the section "Removing cover" from page 19.
- Remove the Allen screws (27).
- Remove the control unit (4) from the body (2).
- Remove the regulator gasket (28).
- For the disposal of the gaskets observe the pertinent on-site regulations concerning waste disposal.

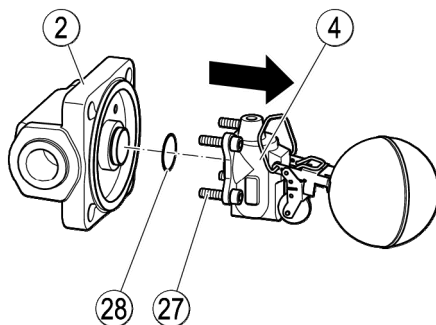

Cleaning the equipment

Check the equipment at regular intervals for contamination. The intervals depend on the amount of dirt in the system. The operator must determine the maintenance intervals.

- Remove any parts that are dirty and cannot be cleaned properly.

To clean the inside of the equipment proceed as follows:

- Remove the cover from the body as described in the section "Removing cover" from page 19.
- Remove the control unit as described in the section "Removing control unit" on page 19.
- To remove dirt deposits rinse the equipment with fresh water and wipe it with a clean, lint-free cloth.

- To remove any persistent residues use a cleaning agent that is suitable for the material and carefully wipe the equipment with a clean, lint-free cloth.
- Secure the control unit to the body as described in the section "*Mounting the control unit*" from page 20.
- Attach the cover to the body as described in the section "*Mounting cover*" from page 21.

Cleaning and checking the membrane regulator capsule

On models with DUPLEX control unit and control membrane, clean the control membrane as follows.

-  The bimetallic vent is installed fixed in the control unit. It cannot be removed.
- Remove the cover from the body as described in the section "*Removing cover*" from page 19.
- Remove the control unit as described in the section "*Removing control unit*" on page 19.
- Remove the membrane regulator capsule as described in section "*Exchanging the membrane regulator capsule*" on page 30.
- Clean the membrane regulator capsule with cold clean water.
- Use a depth gauge to check the dimension x of the membrane regulator capsule as shown in the following drawing.

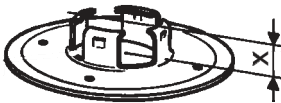

The membrane regulator capsule is intact if dimension x exceeds 4.0 mm.

- Discard and replace defective membrane regulator capsule with a new one.
- Mount the membrane regulator capsule as described in section "*Exchanging the membrane regulator capsule*" on page 30.

Mounting the control unit

Attention!

Malfunctions may occur if the control unit is installed incorrectly.

- When installing the equipment make sure that the name plate points upwards and the float arm is free to move up and down.
- Make sure that the flow arrow on the equipment body matches the direction of flow in the pipe.

- Check all removed parts for signs of damage.
- Replace all worn or damaged parts.
- Clean all dirty parts.
- Apply high-resistant lubricant to all threads, bearing faces of screws, nuts and bolts.

The lubricant must have the same properties as OKS® 217.

Attention!

Equipment may leak if the gasket is damaged.

- Replace all gaskets that you loosen during your work.
- Use only new gaskets of the same type.

- Replace all gaskets with new ones of the same type.
- Insert a new regulator gasket (28) in the body (2).
- Turn the control unit (4) to the desired position.
- Insert the control unit in the body without tilting it.
- Secure the control unit using the four Allen screws (27).

The torque of the Allen screws depends on the model.

- ▶ For models with DN 15 to DN 25, the required torque is 4 Nm.
- ▶ For models with DN 40 to DN 65, the required torque is 7 Nm.
- Tighten the Allen screws to the specified torque.

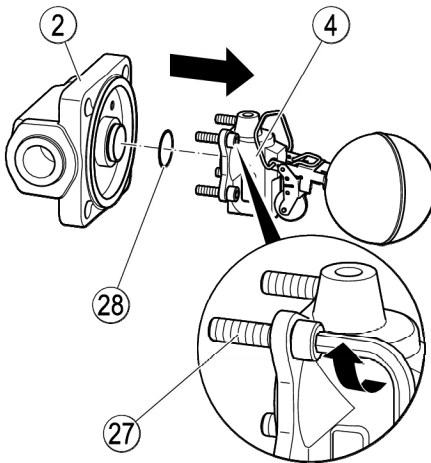

- Attach the cover to the body as described in the section "Mounting cover" from page 21.

Mounting cover

Attention!

Equipment may leak if the gasket is damaged.

- It is therefore essential that you always insert a new gasket before re-attaching the cover.
- Make sure that the cover is not tilted or skewed when refitted.

- Clean the gasket surfaces of the cover and body.
- Apply heat resistant lubricant to the threads and bearing faces of the screws.

The lubricant must have the same properties as OKS® 217.

- Put a new body gasket (3) onto the body (2).
- Insert the four screws (9) into the bores of the body.
- Refit the cover (7) onto the body such that the name plate (6) points upwards.

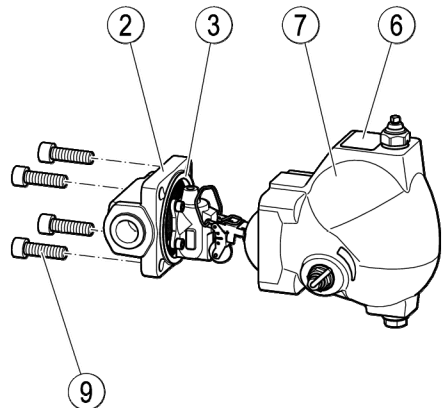



In order to prevent confusion, the covers and bodies of the UNA 45 and UNA 46 are designed differently to those of the UNA 47:

- ▶ On UNA 45/46, the spring is on the body and the groove is on the cover.
- ▶ On UNA 47, the groove is on the body and the spring is on the cover.

The torque of the screws on the body depends on the model.

- ▶ On UNA 45, UNA 46 and UNA 46A with DN 15 to DN 25, the required torque is 35 Nm.
- ▶ On UNA 45, UNA 46 and UNA 46A with DN 40 to DN 65 and UNA 47 with DN 15 to DN 50 the required torque is 140 Nm.
- Tighten the four screws to the specified torque.
- If necessary, fit the measurement electrode as described in the section "*Mounting the measuring electrode*" on page 15.

Servicing the equipment and installing spare parts

You may exchange the following component parts in case of wear or damage:

UNA 45, UNA 46, UNA 46A and UNA 47 with standard cover

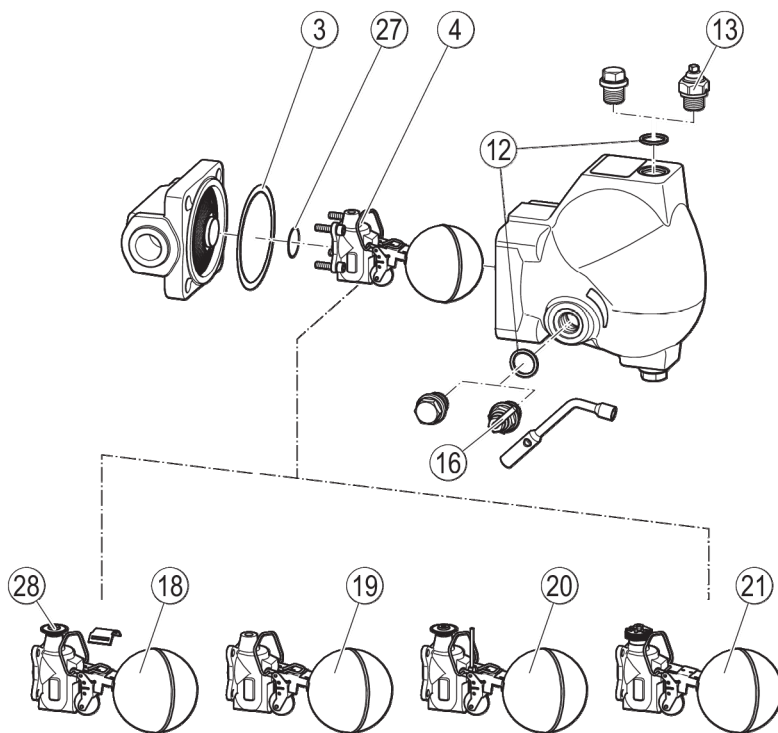

Spare parts for UNA 45, UNA 46, UNA 46A with standard cover				
No.	Designation	Orifice	DN 15-25	DN 40-65
			Stock code	
3, 4, 28	SIMPLEX control unit, complete, with body gasket and regulator gasket	2	560656	560669
		4	560657	560670
		8	560658	560671
		13	560659	560672
		22	560660	560673
		32	560661	560674
3, 19, 28	SIMPLEX-P control unit, complete, with body gasket and regulator gasket	16	560662	–
3, 18, 28, 29	DUPLEX control unit with control membrane, complete, with body gasket and regulator gasket	2	560650	560663
		4	560651	560664
		8	560652	560665
		13	560653	560666
		22	560654	560667
		32	560655	560668
3, 29	Control membrane 5N2, complete, with body gasket	All	560494	560687
12, 13	Manual vent valve, complete, with sealing ring	All	560676	
12, 16	Manual lifting lever, complete, with sealing ring	All	560677	560678
3	Body gasket ¹	All	560493	560680
12	Sealing ring for sealing plug ¾", manual lifting lever, manual vent valve or externally adjustable internal bypass ¹	All	560486 ² or 560514 ²	
28	Regulator gasket ¹	All	560681	560682
3, 12, 28	Seal set ³	All	560683	560684

1 Order quantity 20 items

2 560486: Material 1.4301, 560514: Material 1.4571

3 Contains:

- ▶ Sealing rings ¾" (4 ×)
- ▶ Sealing ring ¼" (1 ×)
- ▶ Body gasket (1 ×)
- ▶ Regulator gasket (1 ×)

Spare parts for UNA 47 with standard cover			
No.	Designation	Orifice	Stock code DN 15–50
3, 4, 28	SIMPLEX control unit, complete, with body gasket and regulator gasket	16	560850
		28	560851
		45	560852
3, 18, 28, 29	DUPLEX control unit with bimetallic vent, complete, with body gasket and regulator gasket	16	560853
		28	560854
		45	560855
12, 13	Manual vent valve, complete, with sealing ring	All	560676
12, 16	Manual lifting lever, complete, with sealing ring	All	560678
3	Body gasket ¹	All	560680
12	Sealing ring for sealing plug $\frac{3}{8}$ " , manual lifting lever, manual vent valve or externally adjustable internal bypass ¹	All	560486 ² or 560514 ²
28	Regulator gasket ¹	All	560682
3, 12, 28	Seal set ³	All	560856

- 1 Order quantity 20 items
- 2 560486: Material 1.4301, 560514: Material 1.4571
- 3 Contains:
 - ▶ Sealing rings $\frac{3}{8}$ " (4 ×)
 - ▶ Body gasket (1 ×)
 - ▶ Regulator gasket (1 ×)

UNA 45 with cover for installing electrodes

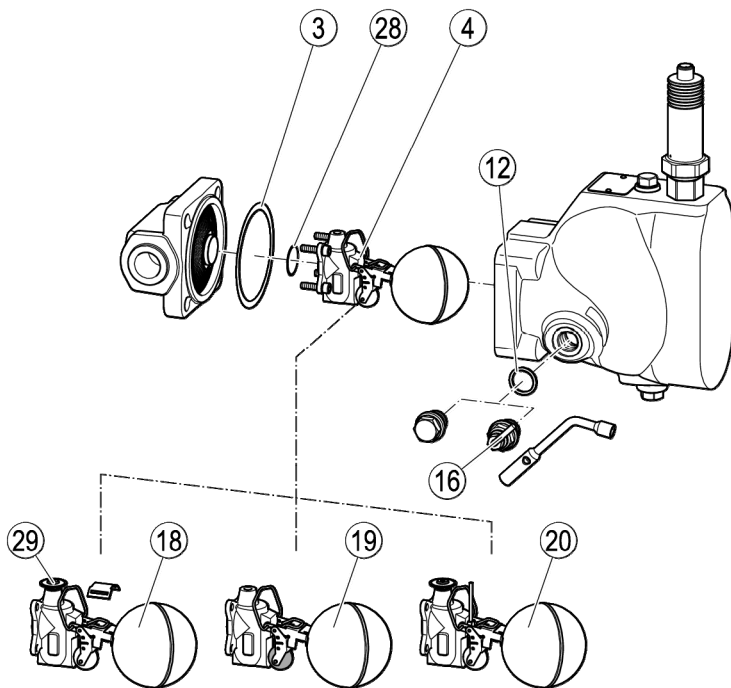

Spare parts for UNA 45 with electrode cover				
No.	Designation	Orifice	DN 15-25	DN 40-65
			Stock code	
3, 4, 28	SIMPLEX control unit, complete, with body gasket and regulator gasket	2	560656	560669
		4	560657	560670
		8	560658	560671
		13	560659	560672
		22	560660	560673
		32	560661	560674
3, 19, 28	SIMPLEX-P control unit, complete, with body gasket and regulator gasket	16	560662	–
3, 18, 28, 29	DUPLEX control unit with control membrane, complete, with body gasket and regulator gasket	2	560650	560663
		4	560651	560664
		8	560652	560665
		13	560653	560666
		22	560654	560667
		32	560655	560668
3, 29	Control membrane 5N2, complete, with body gasket	All	560494	560687
12, 16	Manual lifting lever, complete, with sealing ring	All	560685	560686
3	Body gasket ¹	All	560493	560680
12	Sealing ring for sealing plug 3/8" or manual lifting lever ¹	All	560486 ² or 560514 ²	
27	Regulator gasket ¹	All	560681	560682
3, 12, 28	Seal set ³	All	560683	560684

- 1 Order quantity 20 items
- 2 560486: Material 1.4301, 560514: Material 1.4571
- 3 Contains:
 - ▶ Sealing rings 3/8" (4 ×)
 - ▶ Sealing ring 1/4" (1 ×)
 - ▶ Body gasket (1 ×)
 - ▶ Regulator gasket (1 ×)

UNA 45 with sightglass cover

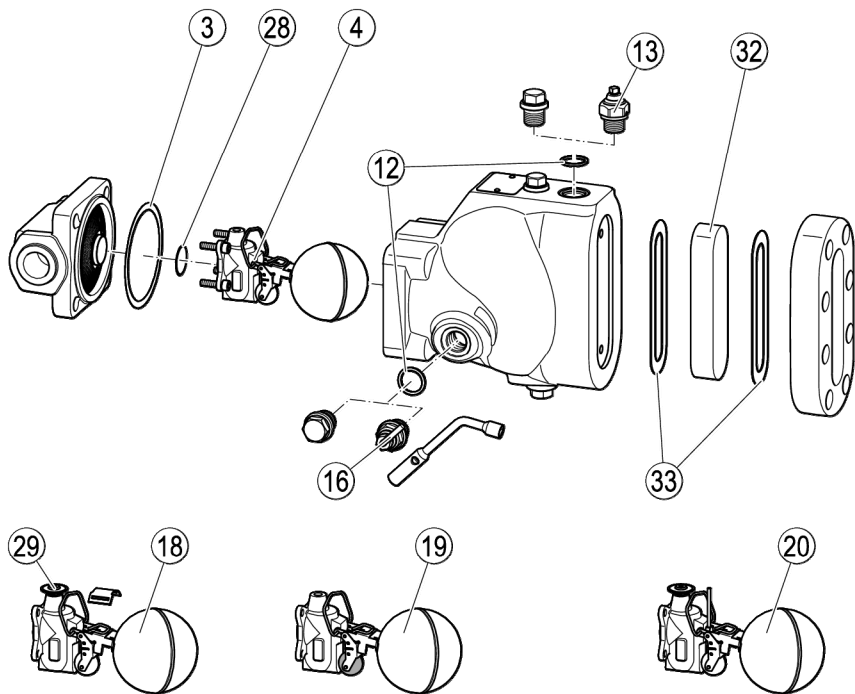

Spare parts for UNA 45 with sightglass				
No.	Designation	Orifice	DN 15-25	DN 40-65
			Stock code	
3, 4, 28	SIMPLEX control unit, complete, with body gasket and regulator gasket	2	560656	560669
		4	560657	560670
		8	560658	560671
		13	560659	560672
3, 19, 28	SIMPLEX-P control unit, complete, with body gasket and regulator gasket	16	560662	–
3, 18, 28, 29	DUPLEX control unit with control membrane, complete, with body gasket and regulator gasket	2	560650	560663
		4	560651	560664
		8	560652	560665
		13	560653	560666
3, 29	Control membrane 5N2, complete, with body gasket	All	560494	560687
12, 13	Manual vent valve, complete, with sealing ring	All	560676	
12, 16	Manual lifting lever, complete, with sealing ring	All	560685	560686
3	Body gasket ¹	All	560493	560680
12	Sealing ring for sealing plug 3/8", manual lifting lever or manual vent valve ¹	All	560486 ² or 560514 ²	
28	Regulator gasket ¹	All	560681	560682
32, 33	Glass water-level gauge with 2 gaskets	All	560685	560480

1 Order quantity 20 items

2 560486: Material 1.4301, 560514: Material 1.4571

Exchanging the control unit

- Remove the cover from the body as described in the section "*Removing cover*" from page 19.
- Remove the control unit as described in the section "*Removing control unit*" on page 19.
- Secure the control unit to the body as described in the section "*Mounting the control unit*" from page 20.
- Attach the cover to the body as described in the section "*Mounting cover*" from page 21.

Exchanging the membrane regulator capsule



The following section applies only to type UNA 45, UNA 46 and UNA 46A devices. On type UNA 47 devices, it is not possible to replace the bimetallic vent.

- Remove the cover from the body as described in the section "*Removing cover*" from page 19.



In equipment with DN 15–DN 25 the cover presses the membrane regulator capsule onto the seat. You can therefore easily detach the membrane regulator capsule from the seat after removing the cover.

In equipment with DN 40 and DN 50 a mounting clip is used to fix the membrane regulator capsule in place. To exchange the membrane regulator capsule first you have to remove the mounting clip. For this purpose you have to remove the control unit. Proceed as follows:

- Pull off the membrane clip (30) from the control unit (1.).
- Pull off the control membrane (29) by lifting it from the seat (31) (2.).

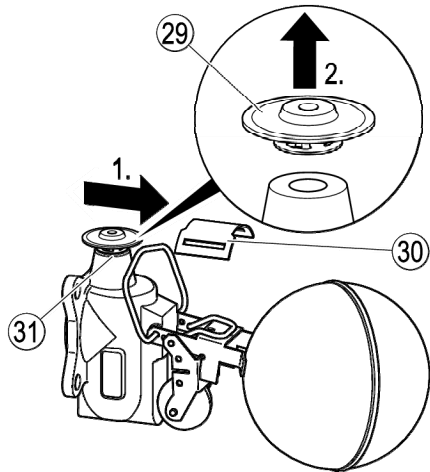

Install the new membrane regulator capsule as follows:

- Press the membrane regulator capsule onto the seat until it snaps into place.
- Slip the mounting clip over the membrane regulator capsule.
- Attach the cover to the body as described in the section "*Mounting cover*" from page 21.

Replacing the sightglass of the sightglass cover

- Remove the Allen screws (35).
- Remove the flange (34) from the sightglass (14).
- Remove the outer gasket (33).
- Remove the water-level gauge (32).
- Remove the inner gasket (33).
- For the disposal of the gaskets observe the pertinent on-site regulations concerning waste disposal.

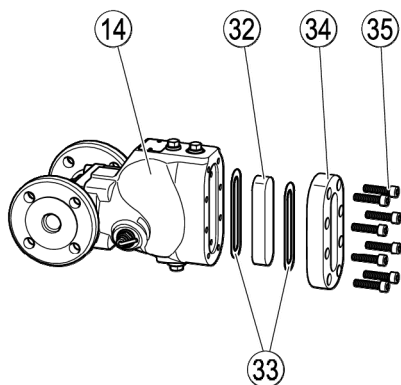

Attention!

Equipment may leak if the gasket is damaged.

- Replace all gaskets that you loosen during your work.
 - Use only new gaskets of the same type.
-
- Apply heat resistant lubricant to the threads and bearing faces of the socket-head cap screws.
- The lubricant must have the same properties as OKS® 217.
- Insert a new gasket in the sightglass cover.
 - Insert a new sightglass.
 - Put a new gasket on the sightglass.
 - Screw the socket-head cap screws into the bores of the flange.
 - Tighten the socket-head cap screws alternately and in several steps with a torque of 12 Nm.

Troubleshooting

Problem	Cause	Remedy
The equipment is cold or only warm to the touch. Insufficient flowrate. Insufficient thermal output of the user.	The inlet or outlet shut-off valves are closed.	Fully open the shut-off valves.
The equipment is cold or only warm to the touch. Insufficient flowrate. Insufficient thermal output of the user.	The inlet, outlet or internals are dirty.	If fitted, operate the float-lifting lever. Clean the pipes. Clean the equipment.
Insufficient flowrate. Insufficient thermal output of the user.	The equipment is undersized.	Install equipment with larger flowrate capacity.
Insufficient flowrate. Insufficient thermal output of the user.	The differential pressure is too small.	Increase the steam pressure. Lower the pressure in the condensate lines. Install equipment with larger flowrate capacity. Use a different equipment type.
Insufficient flowrate. Insufficient thermal output of the user.	The line leading to the equipment does not have a gradient.	Lay the condensate line with a gradient so that the condensate is free to fall towards the equipment. Change the orientation of the pipeline.
Insufficient flowrate. Insufficient thermal output of the user.	Insufficient deaeration.	Connect an additional air vent in accordance with the instructions given by the manufacturer. Use a different equipment type. Contact the manufacturer to find out which trap type is the most suitable for your application.
Insufficient flowrate	You did not remove the sealing plugs from the connections.	Remove the equipment. Remove the sealing plugs. Mount the equipment.
The equipment is blowing off live steam.	Dirt deposits, sediments or foreign particles have accumulated in the equipment.	If fitted, operate the float-lifting lever. Clean the equipment. If necessary, replace internal parts or the whole equipment.

Problem	Cause	Remedy
The equipment is blowing off live steam.	The control unit is damaged or worn.	Replace the control unit. Replace the equipment with a new one.
The equipment is blowing off live steam.	The bypass is open.	Close the bypass.
Fluid escapes (equipment is leaking).	The connections are not tight.	Provide the connections with leakproof seals.
Fluid escapes (equipment is leaking).	A gasket is damaged.	Check the condition of the gaskets. Replace any defective gasket.
Fluid escapes (equipment is leaking).	The body has been damaged by corrosion or erosion.	Check the resistance of the material for the fluid used. Use only equipment made of material that is suitable for the fluid used.
Fluid escapes (equipment is leaking).	The equipment is damaged.	Check the condition of the equipment. Replace the equipment if it is damaged.
Fluid escapes (equipment is leaking).	The equipment has been damaged by frost.	Replace the equipment with a new one. When shutting down the installation make sure that all lines and the equipment are completely drained.
Fluid escapes (equipment is leaking).	The equipment has been damaged by waterhammer.	Replace the equipment with a new one. Take appropriate measures to protect the equipment against waterhammer, e. g. by installing suitable non-return valves.
The stuffing box is leaking.	The stuffing box packing has not been tightened enough.	Tighten the stuffing-box packing hand tight. Make sure that the stuffing box does not impair the movement of the internals. The stuffing box must not leak.
	The stuffing-box packing is damaged.	Replace the stuffing-box packing.

- If faults occur that are not listed above or cannot be corrected, please contact our Technical Service or authorized agency in your country.

Putting the equipment out of operation

Removing harmful substances



DANGER

If the equipment is used in contaminated areas there is a risk of severe injuries or death caused by harmful substances in or on the equipment.

- Only qualified personnel are allowed to perform work on contaminated equipment.
- Always wear the protective clothing prescribed for contaminated areas when working on the equipment.
- Make sure that the equipment is completely decontaminated before carrying out any service work.
- Follow the pertinent instructions for handling the hazardous substances in question.

Qualified personnel must have extensive experience with and a working knowledge of:

- ▶ pertinent rules and regulations concerning handling hazardous substances
- ▶ special regulations for handling the hazardous substances encountered on site
- ▶ using the required personal protective equipment (PPE) and clothing



CAUTION

Environmental damage may be caused by poisonous fluid residues.

- Before disposing of the equipment make sure that it is clean and free of fluid residues.
- For the disposal of all materials observe the pertinent legal regulations concerning waste disposal.

- Remove all residues from the equipment.
- For the disposal of all residues observe the pertinent legal regulations concerning waste disposal.

Removing the equipment



DANGER

Personnel working on pipes are exposed to safety risks and may suffer severe injuries, poisoning or even loss of life.

- Make sure that no hot or hazardous fluid is in the equipment or the pipes.
- Make sure that the pipes upstream and downstream of the equipment are depressurised.
- Make sure that the installation is switched off and protected against unauthorised or unintended activation.
- Make sure that the equipment and the pipes have cooled down to room temperatures.
- Wear protective clothing that is suitable for the fluid and, if necessary, wear protective gear.

For more information on suitable protective clothing and safety gear refer to the safety data sheet of the fluid in question.



CAUTION

Risk of injuries if the equipment falls down.

- When removing the equipment make sure the it is safely held in place and cannot fall down.

Suitable measures are for instance:

- ▶ Equipment that is not too heavy may be supported by a second person.
- ▶ For heavy equipment use suitable lifting equipment of sufficient strength.

- Detach the end connections of the equipment from the pipes.
- Put the equipment onto a suitable base.
- Store the equipment as described on page 11.

Re-using equipment after storage

Observe the following instructions if you want to remove the equipment and use it again somewhere else:

- ▶ Make sure that the equipment is free of any fluid residues.
- ▶ Make sure that all connections are in good condition and leak-free.
- ▶ If necessary re-work welded connections in order to ensure that they are in good working condition.
- Use the equipment only for its intended purpose and the service conditions for which it was specified.

Disposing of the equipment



CAUTION

Environmental damage may be caused by poisonous fluid residues.

- Before disposing of the equipment make sure that it is clean and free of fluid residues.
- For the disposal of all materials observe the pertinent legal regulations concerning waste disposal.

The equipment is made from the following materials:

Component	Type	EN	ASTM
Body	UNA 45, UNA 46	1.0460	A105
	UNA 46A	1.4404	A182-F316L
	UNA 47	1.5415	–
Cover	UNA 45, sightglass, electrode cover	5.3103	A395 ¹
	UNA 46	1.0619	SA216-WCB
	UNA 46A	1.4408	A351-CF8M
	UNA 47	1.5419	–
Body gasket, regulator gasket	All	Graphite CrNi	
Other components	All	Stainless steel	

1 ASTM material is comparable to EN material. Note the differences in chemical and physical properties.

Technical data

Dimensions and weights

The drawing shows equipment with standard cover and flanged connection for vertical downward flow.

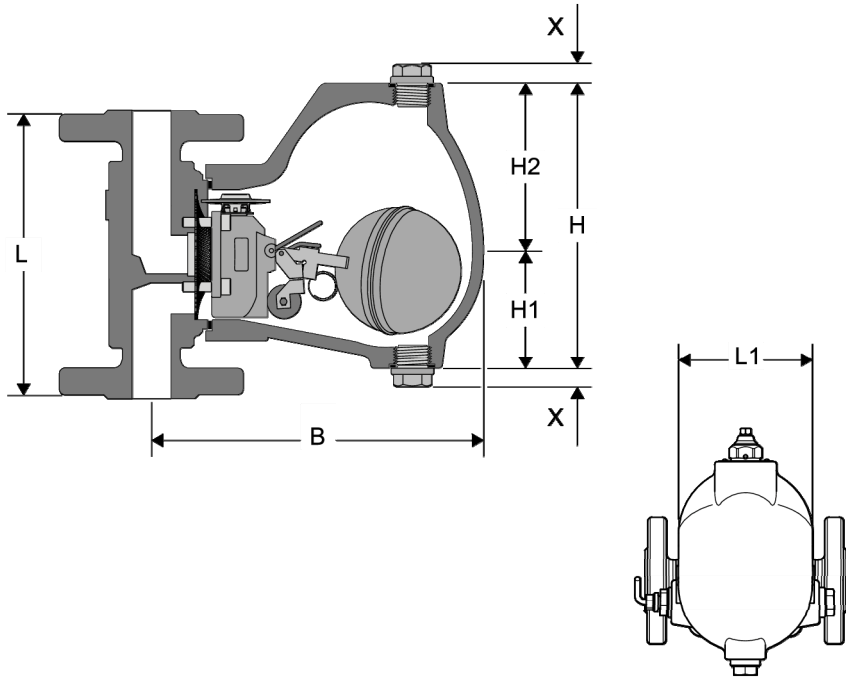

UNA 45, UNA 46 and UNA 46A with flange EN 1092-1 PN 10–40

Nominal diameter	DN 15 (½")	DN 20 (¾")	DN 25 (1")	DN 40 (1½")	DN 50 (2")	DN 65 (2½")
Installed length L [mm (in)]	150 (5.9)		160 (6.3)	230 (9.1)		290 (11.4)
W [mm (in)]						
Standard cover	171 (6.7)			287 (11.3)		
Sightglass	213 (8.4)			333 (13.1)		
Electrode cover	186 (7.3)			306 (12.0)		
H1 [mm (in)]	60 (2.4)			107 (4.2)		
H2 [mm (in)]	90 (3.5) ¹			151 (5.9) ¹		
Total height H [mm (in)]	150 (5.9) ¹			258 (10.2) ¹		
Width L1 [mm (in)]	110 (4.3) ²			170 (6.7) ²		
X [mm (in)]	13 (0.5)					
Weight [kg]						
Standard cover	6.8	7.3	7.8	24.8	26.2	28.6
Sightglass	9.7	10.2	10.7	30.5	31.9	34.3
Electrode cover	8.5	9.0	9.5	28.0	29.4	31.8
Weight [lb]						
Standard cover	15.0	16.1	17.2	54.7	57.8	63.1
Sightglass	21.4	22.5	23.6	67.2	70.3	75.6
Electrode cover	18.7	19.8	20.9	61.7	64.8	70.1

- 1 Plus 25 mm (1 in) if fitted with manual vent valve.
- 2 Plus 35 mm (1.4 in) if fitted with manual lifting lever or bypass.

UNA 47 DN 15–50 with flange EN 1092-1 B2 PN 63

Nominal diameter	DN 15 (½")	DN 20 (¾")	DN 25 (1")	DN 40 (1½")	DN 50 (2")
Installed length L [mm (in)]	230 (9.1)	260 (10.3)		290 (11.5)	
W [mm (in)]	290 (11.5)				
H1 [mm (in)]	110 (4.4)				
H2 [mm (in)]	155 (6.2) ¹				
Total height H [mm (in)]	260 (10.3) ¹				
Width L1 [mm (in)]	175 (6.8) ²				
X [mm (in)]	13 (0.5)				
Weight [kg]	26	28	29	33	34
Weight [lb]	57.3	61.7	64.0	63.9	75.0

- 1 Plus 25 mm (1 in) if fitted with manual vent valve.
- 2 Plus 35 mm (1.4 in) if fitted with manual lifting lever.

Special length UNA 47hl with flange EN 1092-1 B2 PN 63

Nominal diameter	DN 25 (1")	DN 40 (1½")	DN 50 (2")
Installed length L [mm (in)]	300 (11.9)	420 (16.6)	416 (16.4)
W [mm (in)]	290 (11.5)		
H1 [mm (in)]	110 (4.4)		
H2 [mm (in)]	155 (6.2) ¹		
Total height H [mm (in)]	260 (10.3) ¹		
Width L1 [mm (in)]	175 (6.8) ²		
X [mm (in)]	13 (0.5)		
Weight [kg]	29	35	37
Weight [lb]	64.0	77.2	81.6

- 1 Plus 25 mm (1 in) if fitted with manual vent valve.
- 2 Plus 35 mm (1.4 in) if fitted with manual lifting lever.

UNA 45, UNA 46 and UNA 46 with flange ASME B16.5 Class 150/300

Nominal diameter	DN 15 (½")	DN 20 (¾")	DN 25 (1")	DN 40 (1½")	DN 50 (2")	DN 65 (2½")
Installed length L [mm (in)]	150 (5.9)		160 (6.3)	241 (9.5)	267 (10.5)	292 (11.5)
W [mm (in)]						
Standard cover	171 (6.7)		287 (11.3)			
Sightglass	213 (8.4)		333 (13.1)			
Electrode cover	186 (7.3)		306 (12.0)			
H1 [mm (in)]	60 (2.4)		107 (4.2)			
H2 [mm (in)]	90 (3.5) ¹		151 (5.9) ¹			
Total height H [mm (in)]	150 (5.9) ¹		258 (10.2) ¹			
Width L1 [mm (in)]	110 (4.3) ²		170 (6.7) ²			
X [mm (in)]	13 (0.5)					
Weight class 150						
Weight [kg]						
Standard cover	6.2	6.6	7.2	23.8	25.9	29.4
Sightglass	9.1	9.5	10.1	29.5	31.6	35.1
Electrode cover	7.9	8.3	8.9	27.0	29.1	32.6
Weight [lb]						
Standard cover	13.7	14.6	15.9	52.5	57.1	64.8
Sightglass	20.1	20.9	22.3	65.0	69.7	77.4
Electrode cover	17.4	18.3	19.6	56.2	60.8	68.6
Weight class 300						
Weight [kg]						
Standard cover	6.6	7.4	8.2	26.0	27.5	31.1
Sightglass	9.5	10.3	11.1	31.7	33.2	36.8
Electrode cover	8.3	9.1	9.9	29.2	30.7	34.3
Weight [lb]						
Standard cover	14.6	16.3	18.1	57.3	60.6	68.6
Sightglass	20.9	22.7	24.5	69.9	73.2	81.1
Electrode cover	18.3	20.1	21.8	64.4	67.7	75.6

- 1 Plus 25 mm (1 in) if fitted with manual vent valve.
- 2 Plus 35 mm (1.4 in) if fitted with manual lifting lever or bypass.

UNA 47 PN63 with flange ASME B16.5 class 400/600

Nominal diameter	DN 15 (½")	DN 20 (¾")	DN 25 (1")	DN 40 (1½")	DN 50 (2")
Installed length L [mm (in)]	241 (9.5)	267 (10.5)		292 (11.5)	
W [mm (in)] standard cover	290 (11.5)				
H1 [mm (in)]	110 (4.4)				
H2 [mm (in)]	155 (6.2) ¹				
Total height H [mm (in)]	260 (10.3) ¹				
Width L1 [mm (in)]	175 (6.8) ²				
X [mm (in)]	13 (0.5)				
Weight [kg]	25	26	27	32	34
Weight [lb]	55.1	57.3	59.5	70.5	75.0

- 1 Plus 25 mm (1 in) if fitted with manual vent valve.
- 2 Plus 35 mm (1.4 in) if fitted with manual lifting lever.

UNA 45, UNA 46 and UNA 46A with socket-weld end, socket-weld end via transition piece

Nominal diameter	DN 15 (½")	DN 20 (¾")	DN 25 (1")	DN 40 (1½")	DN 50 (2")	DN 65 (2½")
Installed length L [mm (in)]	95 (3.7)			165 (6.5)	267 (10.5)	292 (11.5)
	(Socket-weld end)				(Socket-weld end via transition pieces EN, ASME)	
W [mm (in)]						
Standard cover	171 (6.7)			287 (11.3)		
Sightglass	213 (8.4)			333 (13.1)		
Electrode cover	186 (7.3)			306 (12.0)		
H1 [mm (in)]	60 (2.4)			107 (4.2)		
H2 [mm (in)]	90 (3.5) ¹			151 (5.9) ¹		
Total height H [mm (in)]	150 (5.9) ¹			258 (10.2) ¹		
Width L1 [mm (in)]	110 (4.3) ²			170 (6.7) ²		
X [mm (in)]	13 (0.5)					
Weight [kg]						
Standard cover	5.3	5.2		21.2	21.9	24.6
Sightglass	8.2	8.1		26.9	27.6	30.3
Electrode cover	7.0	6.9		24.4	25.1	27.8
Weight [lb]						
Standard cover	11.7	11.5		46.7	48.3	54.5
Sightglass	18.1	17.9		59.3	60.8	67.0
Electrode cover	15.4	15.2		53.8	55.3	61.5

- 1 Plus 25 mm (1 in) if fitted with manual vent valve.
- 2 Plus 35 mm (1.4 in) if fitted with manual lifting lever or bypass.

UNA 47 DN15 to DN40 with socket-weld end, UNA 47 DN50 with socket-weld end via transition piece

Nominal diameter	DN 15 (½")	DN 20 (¾")	DN 25 (1")	DN 40 (1½")	DN 50 (2")
Installed length L [mm (in)]	165 (6.5) (socket-weld end)				290 (11.4) (socket-weld end via transition piece EN, ASME)
W [mm (in)]	290 (11.5)				
H1 [mm (in)]	60 (2.4)				
H2 [mm (in)]	90 (3.5) ¹				
Total height H [mm (in)]	150 (5.9) ¹				
Width L1 [mm (in)]	110 (4.3) ²				
X [mm (in)]	13 (0.5)				
Weight [kg]	24	23		25	27
Weight [lb]	52.9	50.7		55.1	59.5

- 1 Plus 25 mm (1 in) if fitted with manual vent valve.
- 2 Plus 35 mm (1.4 in) if fitted with manual lifting lever.

UNA 45, UNA 46 and UNA 46A with screwed socket

Nominal diameter	DN 15 (½")	DN 20 (¾")	DN 25 (1")	DN 40 (1½")	DN 50 (2")
Installed length L [mm (in)]	95 (3.7)			165 (6.5)	
W [mm (in)]	171 (6.7)			287 (11.3)	
Standard cover	171 (6.7)			287 (11.3)	
Sightglass	213 (8.4)			333 (13.1)	
Electrode cover	186 (7.3)			306 (12.0)	
H1 [mm (in)]	60 (2.4)			107 (4.2)	
H2 [mm (in)]	90 (3.5) ¹			151 (5.9) ¹	
Total height H [mm (in)]	150 (5.9) ¹			258 (10.2) ¹	
Width L1 [mm (in)]	110 (4.3) ²			170 (6.7) ²	
X [mm (in)]	13 (0.5)				
Weight [kg]					
Standard cover	5.3	5.2	5.1	21.2	20.9
Sightglass	8.2	8.1	8.0	26.9	26.6
Electrode cover	7.0	6.9	6.8	24.4	24.1
Weight [lb]					
Standard cover	11.7	11.5	11.2	46.7	46.1
Sightglass	18.1	17.9	17.6	59.3	58.6
Electrode cover	15.4	15.2	15.0	53.8	53.1

1 Plus 25 mm (1 in) if fitted with manual vent valve.

2 Plus 35 mm (1.4 in) if fitted with manual lifting lever or bypass.

UNA 45, UNA 46 and UNA 46A with socket-weld ends via transition pieces

Nominal diameter	DN 15 (½")	DN 20 (¾")	DN 25 (1")	DN 40 (1½")	DN 50 (2")	DN 65 (2½")
Installed length L [mm (in)]	200 (7.9)			241 (9.5)	267 (10.5)	292 (11.5)
W [mm (in)]						
Standard cover	171 (6.7)			287 (11.3)		
Sightglass	213 (8.4)			333 (13.1)		
Electrode cover	186 (7.3)			306 (12.0)		
H1 [mm (in)]	60 (2.4)			107 (4.2)		
H2 [mm (in)]	90 (3.5) ¹			151 (5.9) ¹		
Total height H [mm (in)]	150 (5.9) ¹			258 (10.2) ¹		
Width L1 [mm (in)]	110 (4.3) ²			170 (6.7) ²		
X [mm (in)]	13 (0.5)					
Weight [kg]						
Standard cover	5.6		5.7	21.3	21.6	22.5
Sightglass	8.5		8.6	27.0	27.3	28.2
Electrode cover	7.3		7.4	24.5	24.8	25.7
Weight [lb]						
Standard cover	12.3		12.6	47.0	47.6	49.6
Sightglass	18.7		19.0	59.5	60.2	62.2
Electrode cover	16.1		16.3	54.0	54.7	56.7

- 1 Plus 25 mm (1 in) if fitted with manual vent valve.
- 2 Plus 35 mm (1.4 in) if fitted with manual lifting lever or bypass.

UNA 47 with socket-weld ends via transition pieces

Nominal diameter	DN 15 (½")	DN 20 (¾")	DN 25 (1")	DN 40 (1½")	DN 50 (2")
Installed length L [mm (in)]	230 (9.1)	260 (10.3)		290 (11.5)	
W [mm (in)]	290 (11.5)				
H1 [mm (in)]	110 (4.4)				
H2 [mm (in)]	155 (6.2) ¹				
Total height H [mm (in)]	260 (10.3) ¹				
Width L1 [mm (in)]	175 (6.8) ²				
X [mm (in)]	13 (0.5)				
Weight [kg]	24			26	
Weight [lb]	52.9			57.3	

- 1 Plus 25 mm (1 in) if fitted with manual vent valve.
- 2 Plus 35 mm (1.4 in) if fitted with manual lifting lever.

Space required for servicing

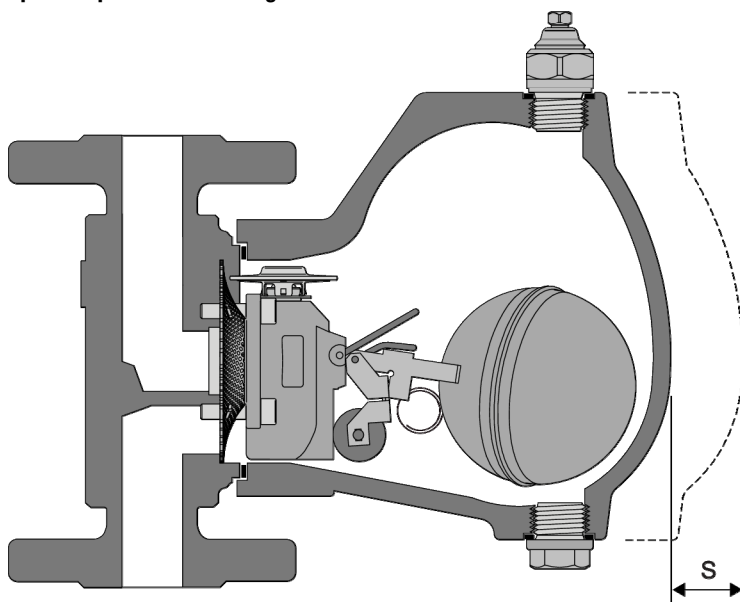

To remove the cover a withdrawal space S of 240 mm is required.

If the supplied socket spanner is attached to the equipment an additional clearance of 100 mm is required.

Pressure & temperature ratings

You can find the values for your equipment on the rating plate.

Operating data

Models with sightglass:

PN16: maximum operating temperature 240 °C at 12.3 bar operating pressure

Class 150: maximum operating temperature 240 °C at 12.4 bar operating pressure. °C, the glass will suffer more wear.

Models with measurement electrode NRG 16–19 or NRG 16–27, PN40/Class 300: maximum operating temperature 238 °C at 32 bar operating pressure

Models with SIMPLEX-P control unit with Perbunan roller ball: maximum operating temperature 40 °C at Δ PMX of 16 bar.

Models with DUPLEX control unit with control membrane: The maximum operating temperature is equal to the saturated steam temperature +5 K.

According to the AD 2000 regulation, the temperature limit is 300 °C for resistance to intercrystalline corrosion on UNA 46A, material 1.4408.

The maximum differential pressure Δ PMX of the device depends on the orifice used.

UNA 47, DN 15–50

Orifice	Δ PMX [bar]	Hole diameter [mm]
16	16	8.5
28	28	7.0
45	45	6.5

UNA 45, UNA 46 and UNA 46A

Orifice	Δ PMX [bar]	Hole diameter [mm]	
		DN 15-25	DN 40-65
2	2	8	15.0
4	4	6	12.5
8	8	4.8	10.0
13	13	4.1	8.5
22	22	3.5	7.0
32	32	3.0	6.5

Manufacturer's declaration

You can find details on the conformity of the equipment in our Declaration of Conformity or Manufacturer's Declaration.

You can download the latest Declaration of Conformity or Manufacturer's Declaration at www.gestra.com or request it from the address below:

GESTRA AG

Münchener Straße 77

28215 Bremen

Germany

Telefon +49 421 3503-0

Telefax +49 421 3503-393

E-Mail info@de.gestra.com

Web www.gestra.com

This declaration is no longer valid if modifications are made to the equipment without consultation with us.



Agencies all over the world: www.gestra.com

GESTRA AG

Münchener Strasse 77

28215 Bremen

Germany

Phone +49 421 3503-0

Fax +49 421 3503-393

e-mail info@de.gestra.com

Web www.gestra.com

819311-03/10-2021 kx_mm (808915-03) © GESTRA AG Bremen Printed in Germany