

UNA 25-PK/PS

Pump Trap

UNA 25-PK, PN 40, DN 40

Condensate Lifter

UNA 25-PS, PN 40, DN 40

Description

UNA 25-PS and UNA 25-PK is steam process equipment designed for the effective removal of condensate from steam.

Condensate is discharged by means of motive steam.

The equipment can therefore remove condensate even if the steam pressure is so low that conventional steam traps could no longer discharge condensate.

Equipment type UNA 25-PS works as cyclic condensate lifter without valve closure. In this case the upstream pressure must be lower than the back pressure.

Equipment type UNA 25-PK works in pumping mode as cyclic condensate lifter with rolling ball valve closure.

If there is (enough) differential pressure, this type of equipment will also work as modulating steam trap.

UNA 25-PS

Condensate enters the trap body and causes the float to rise.

Once the upper tripping point is reached the float operates the valve control linkage. The valve control linkage opens the motive steam inlet and closes the vent valve.

The motive steam forces the condensate through the immersion tube out of the trap body. As the condensate level falls, the float sinks.

During this pumping process condensate collects in the supply line.

As soon as the float has reached its lower tripping point, the valve control linkage closes the motive steam inlet and opens the vent valve.

Condensate flows into the trap body and a new cycle begins.

The gas-tight non-return valve prevents backflow of condensate or motive steam through the condensate inlet. The spring-loaded ball in the outlet prevents backflow at the condensate outlet.

UNA 25-PK

If the upstream pressure of the condensate is higher than the back pressure, UNA 25-PK works in normal operating mode.

If the differential pressure is sufficient, equipment type UNA 25-PK works in continuous trapping mode with leak-proof rolling ball valve closure. If the differential pressure is too low, the equipment works as cyclic condensate lifter.

Condensate enters the trap body and causes the float to rise.

The float moves the rolling ball, thereby opening the orifice (O). An open orifice allows the condensate to be drained continuously. The vent valve is now open.

As the condensate level falls within the trap body, the float sinks and, by closing the orifice, provides a leakproof seal.

If the upstream pressure of the condensate is lower than the back pressure, condensate cannot drain. The condensate level within the trap body rises. The float is lifted until it reaches its upper tripping point for the valve control linkage.

The valve control linkage opens the motive steam inlet and closes the vent valve.

The equipment works now as cyclic condensate lifter. This function is described in the section on the UNA 25-PS.

Technical data

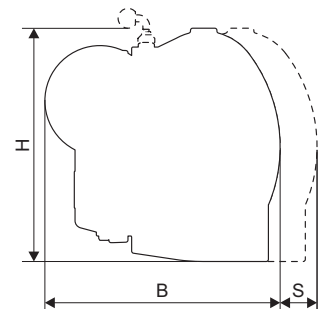

Dimensions and weights

	End connection	
Overall length [mm]	Flange DIN/EN	230
	Screwed sockets G, NPT, Flange Class 150	227
Width B [mm]		325
Space required for servicing S [mm]	(all)	200
Total height H [mm]		318
Weight [kg]	Flanges	31
	Screwed sockets G, NPT	26

Pressure & temperature ratings

Pressure/temperature limits for flange PN 40 to EN 1092-2, screwed ends G to EN ISO 228-1, 1½, Screwed sockets NPT to ASME B1.20.1, 1½				
p (pressure) [bar]	40.5	38.3	31.6	25.0
T (temperature) [bar]	20	120	250	350

Pressure/temperature limits for flange Class 150 to ASME B16.5				
p (pressure) [bar]	17.2	13.9	12.1	6.6
T (temperature) [bar]	20	200	250	350

Motive steam pressure, differential pressure and back pressure	UNA 25-PK	UNA 25-PK UNA 25-PS
Max. motive steam pressure and differential pressure Δ PMX [bar]	6	13
Max. operating back pressure PMOB [bar]	3	5

Orifice, only UNA 25-PK

	Kvs value [m³/h]	Diameter of bore [mm]
Orifice 6	3.5	11.0
Orifice 13	2.1	8.5

Capacity Charts

For UNA 25-PK the charts indicate the max. flowrates of hot condensate for steam trapping and pumping mode.

The charts show the maximum capacities for hot condensate for UNA 25-PS.

The capacities are dependent on the differential pressure (working pressure). The differential pressure is the difference between inlet and outlet pressure and depends among other things on the run of the condensate line. If the condensate downstream of the trap is lifted, the differential pressure is reduced by approximately 1 bar for 7 m lift.

The max. admissible differential pressure depends on the density of the fluid to be discharged. The max. admissible differential pressure for UNA 25-PK depends, in addition, on the cross-sectional area of the orifice.

How to calculate the pumping capacity

The flowrate values indicated in both pumping capacity charts are based on a filling head of 1 m. If the filling head is higher or lower than 1 m use the chart "Influence of filling head on pumping capacity" in order to ascertain the influencing factor of the filling head. The actual pumping capacity is obtained by multiplying the pumping capacity specified in the chart with the influencing factor.

Actual pumping capacity = pumping capacity indicated in chart x influencing factor

Materials

Component part	EN number	ASTM ¹⁾
Body	5.3103	A 395
Cover	5.3103	A 395
Internals	Stainless steel	

1) Physical and chemical properties comply with EN grade. ASTM nearest equivalent grade is stated for guidance only.

Condensate capacity during normal operation (only UNA 25-PK)

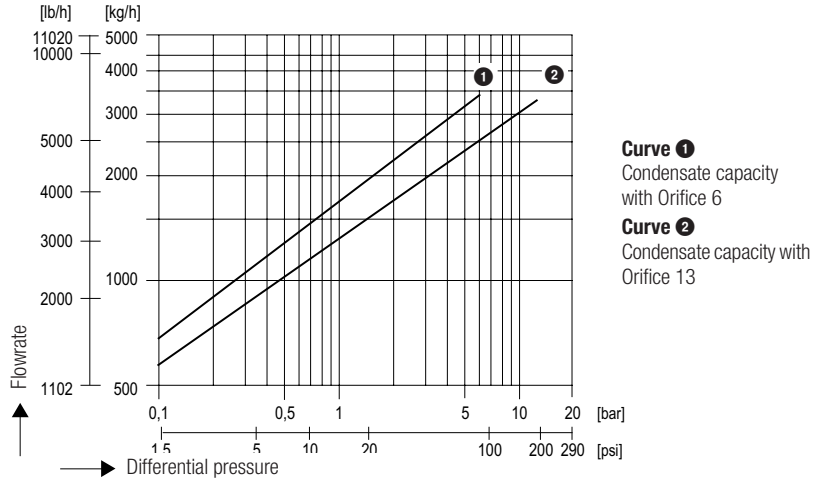

Pumping capacity for UNA 25-PK with Orifice 6 and max. 6 bar motive steam pressure

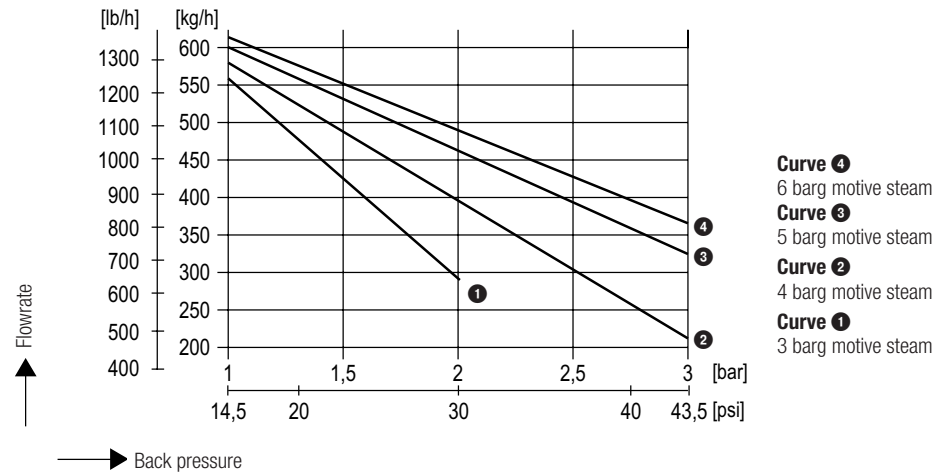

Pumping capacity for UNA 25-PS, UNA 25-PK with Orifice 13 and max. 13 bar motive steam pressure

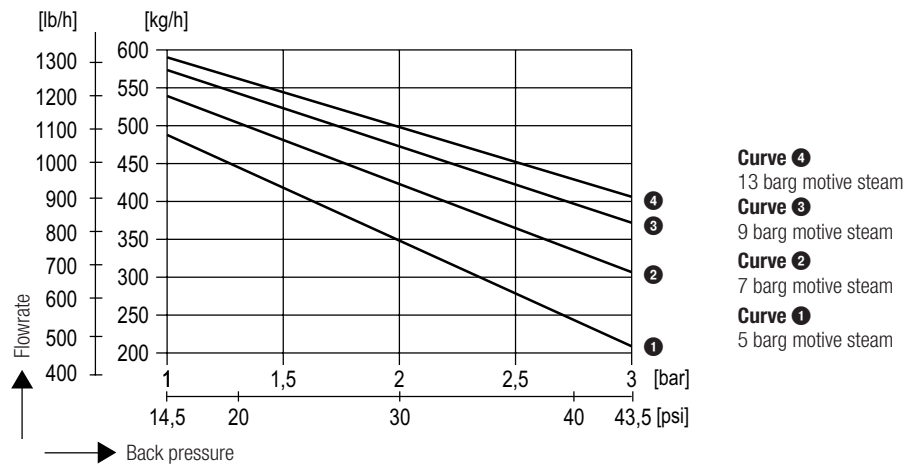

Influence of filling head on pumping capacity

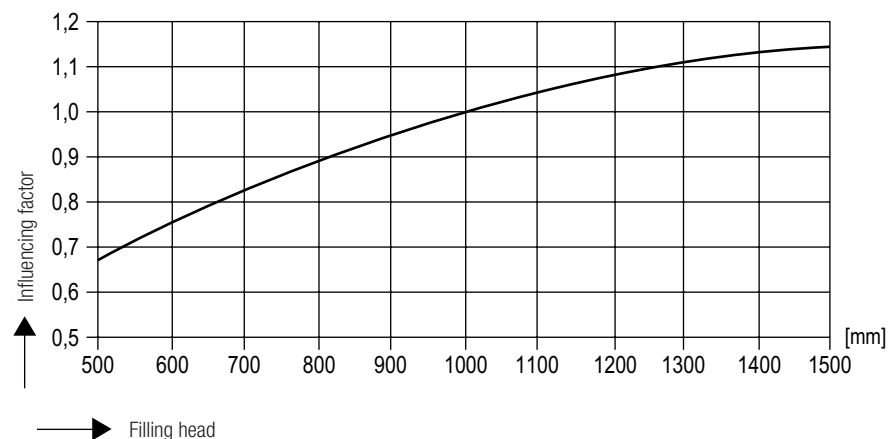

Equipment specification

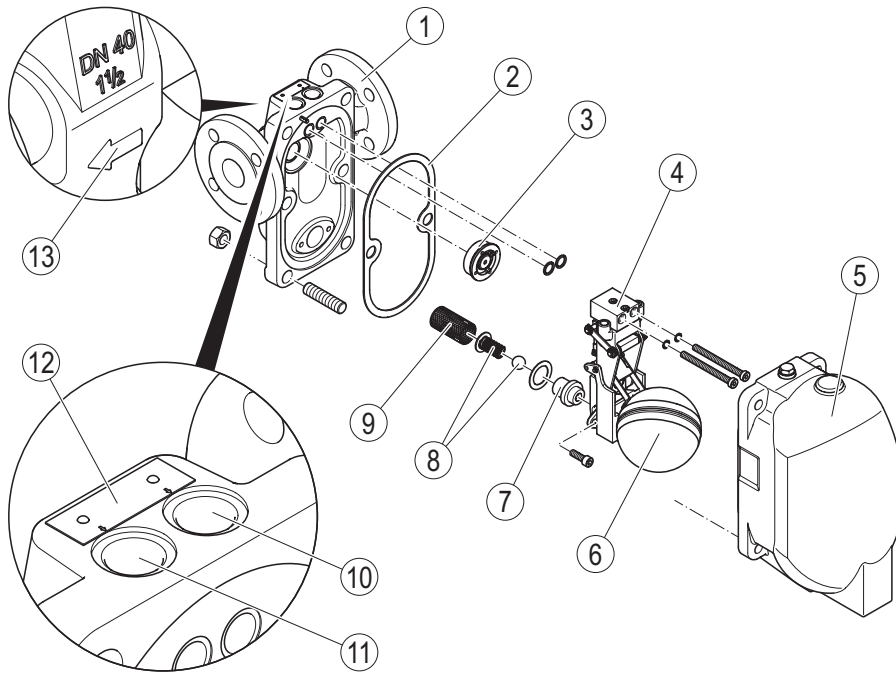

Key

- 1 Body
- 2 Gasket
- 3 Inlet non-return valve RK
- 4 Control unit (shown here: UNA 25-PK)
- 5 Cover
- 6 Float
- 7 Closing element (orifice, for UNA 25-PK)
(for UNA 25-PS: seat)
- 8 Outlet non-return valve RK
- 9 Anti-wear element
- 10 Connection for motive steam line
- 11 Connection for vent line
- 12 Name plate
- 13 Direction of flow arrow

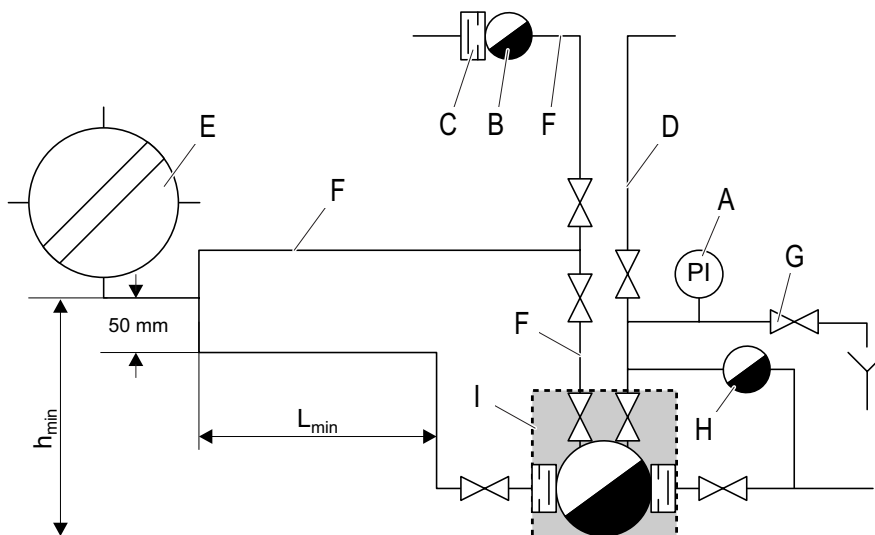

Important Notes

The equipment must be hooked up to the pipes as shown in the graphical representation.

Please take the following items into consideration:

- ▶ A motive steam line must be available and connected (connection: female thread, G $\frac{1}{2}$)
- ▶ A vent line must be available and connected (connection: female thread, G $\frac{1}{2}$)
- ▶ Minimum filling head required between condensate outlet of the heat exchanger and the bottom of the equipment: 0.5 m.
- ▶ An inlet line (min. length 2.5 m) or buffer reservoir (volume: 3 l) is required.
- ▶ Maximum motive steam pressure, depending on design, is 6 or 13 barg.
- ▶ Minimum motive steam pressure is 3 barg. The motive steam pressure must be 1 bar higher than the back pressure.

Key

- A Pressure gauge
- B Thermostatic steam trap for air venting, e. g. MK
- C Optional non-return valve in order to prevent air from entering if a vacuum is formed.
- D Motive steam line (drained, DN 15)
- E Heat exchanger
- F Vent line, DN 15
- G Pressure compensation valve
- H Thermostatic steam trap for draining motive steam line
- I UNA 25-PK/UNA 25-PS

L_{\min} 2.5 m, DN 40

h_{\min} 0.5 m

Pump Trap

UNA 25-PK, PN 40, DN 40

Condensate Lifter

UNA 25-PS, PN 40, DN 40

UNA 25-PS

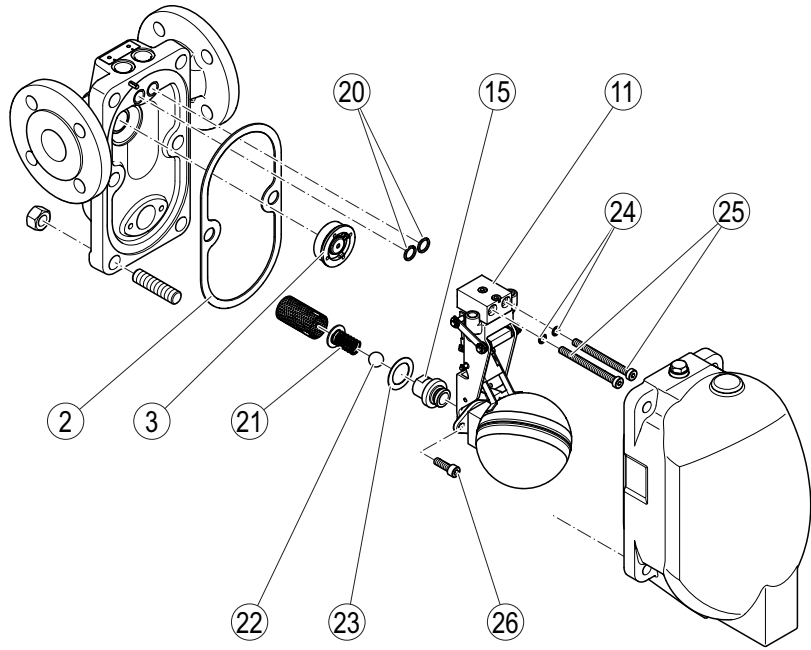

UNA 25-PK

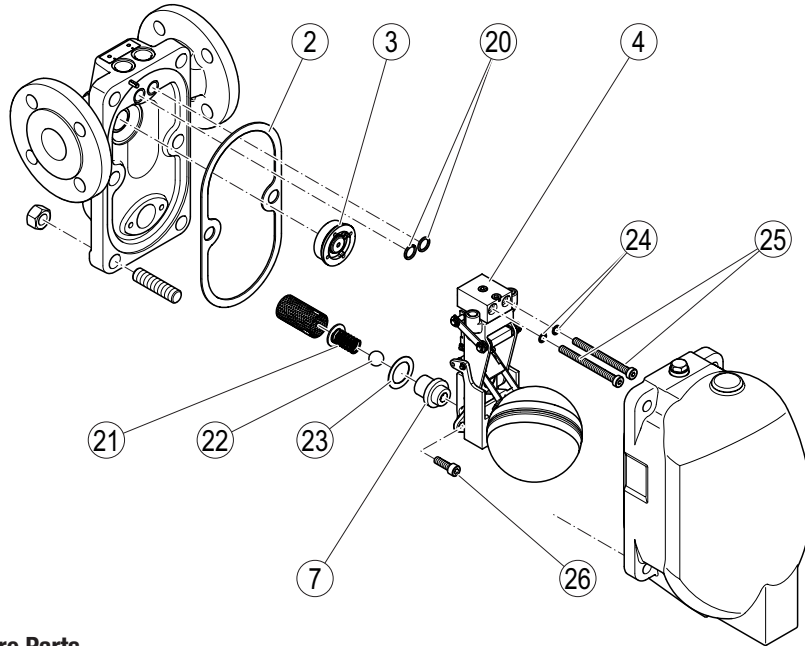

Inspection & Certification

Documentation regarding material tests and in-house examination with test report EN10204 available. All inspection requirements have to be stated with the enquiry or order. After supply of the equipment certification cannot be established. Charges and extent of the above mentioned test certificates as well as the different tests confirmed therein are listed in our Price List "Test and Inspection Charges for Standard Equipment". For other tests and inspections than those listed above, please consult us.

Application of European Directives

Pressure Equipment Directive (PED)

The equipment conforms to this directive and can be used for the following media:

- Fluids of group 2

ATEX Directive

The equipment does not have its own potential ignition source and is not subject to this directive.

Static electricity: When installed, static electricity may arise between the equipment and the connected system.

When used in potentially explosive atmospheres, the plant manufacturer or plant operator is responsible for discharging or preventing possible static charge.

If it is possible for medium to escape, e.g. through actuating mechanisms or leaks in threaded joints, the plant manufacturer or plant operator must take this into consideration when dividing the area into zones.

Supply in accordance with our general terms of business.

Spare Parts

Item no.	Designation	Stock code #	
		UNA 25-PK	UNA 25-PS
2, 4, 20, 23, 24, 25, 26	Control unit UNA 25-PK, complete	560593	–
	Control unit UNA 25-PK, AO 13, complete	560624	–
2, 11, 20, 23, 24, 25, 26	Control unit UNA 25-PS, complete	–	560594
2, 3, 20, 23, 24, 25, 26	Inlet non-return valve, cpl.	560595	
2, 7, 20, 21, 22, 23, 24, 25, 26	Outlet non-return valve, UNA 25-PK, cpl.	560597	–
	Non-return valve UNA 25-PK, AO 13, complete	560625	–
2, 15, 20, 21, 22, 23, 24, 25, 26	Outlet non-return valve, UNA 25-PS, cpl.	–	560598

GESTRA AG

Münchener Straße 77, 28215 Bremen, Germany
 Telefon +49 421 3503-0, Telefax +49 421 3503-393
 E-mail info@de.gestra.com, Web www.gestra.de

