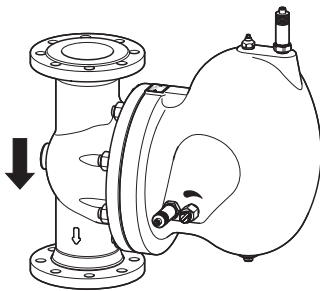

UNA 43 hl, UNA 46 hl

 UNA 43 v, UNA 46 v
with optional extras/accessories

Ball Float Steam Trap

UNA 43 PN 16/CL 125/JIS 10K
UNA 46 PN 40/CL 150/CL 300/JIS 10K/JIS 20K
DN 80, 100, 150, 3", 4", 6"

Description

Steam traps type UNA 43 and UNA 46 are designed for draining condensate from steam systems.

Steam traps type UNA 43 can also be used for removing condensate from compressed air systems.

Steam traps type UNA 46 can also be used for removing condensate from gases or gas mixtures.

The equipment must only be used within the allowable pressure and temperature limits and only if the chemical and corrosive influences on the equipment are taken into account.

Function

The control unit opens the orifice as a function of the liquid level. A rising level results in a proportional opening of the equipment. The max. discharge capacity depends on the orifice size when the ball is completely lifted off its seat and the orifice is fully open.

Optional extras

Float-lifting lever allows the float to be manually lifted (for purging any dirt away from the seat area)

Hand-vent valve allows manual air-venting the pipeline

Accessories

Magnetically operated liquid level gauge

Insulation

NRG 16-19 or NRG 16-27

End connections

UNA 43:

Flange EN 1092-2 B PN 16

Flange ASME B 16.1 Class 125 FF

Flange JIS B 2239 10K

UNA 46:

Flange EN 1092-1 B1 PN 40

Flange ASME B 16.5 Class 150 RF

Flange ASME B 16.5 Class 300 RF

Flange JIS B 2220 10K

Flange JIS B 2220 20K

Flange KS available on request

The different equipment versions allow you to adjust the flow direction of the equipment to the flow pattern of your installation. The flow arrow must correspond to the direction of the fluid flow. The following positions of installation are possible:

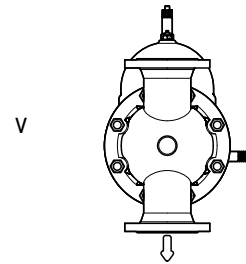

Design "v" for installation in vertical line with downward flow

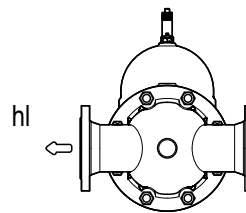

Design "hl" for installation in horizontal line with flow direction left

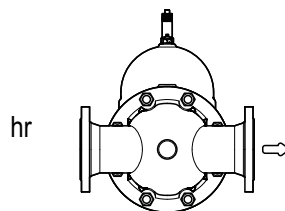

Design "hr" for installation in horizontal line with flow direction right

Materials

Component part	Type	EN	ASTM
Body	UNA 43	5.1301	A126-B
	UNA 46	1.0619	SA216-WCB
Cover	UNA 43	5.1301	A126-B
	UNA 46	1.0619	SA216-WCB
Body gasket, control unit gasket, adapter gasket	all	Graphite CrNi	
Membrane regulator capsule	all	Hastelloy / stainless steel	
Sealing plugs, stud bolts, nuts, manual float-lifting lever	all	Forged steel, heat resistant	
Other components	all	Stainless steel	

Design

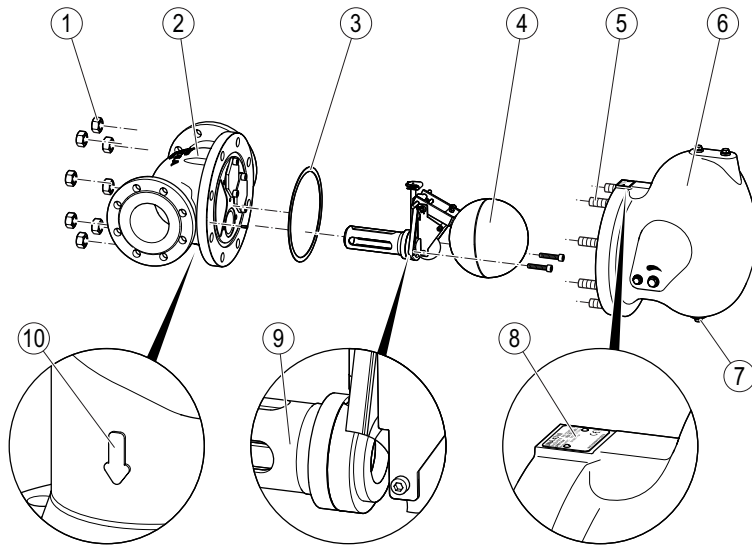

Item no.	Designation
1	Hexagon nuts
2	Body
3	Body gasket
4	Control unit DUPLEX
5	Stud bolts
6	Cover
7	Drain with sealing plug
8	Name plate
9	Adapter
10	Direction of flow arrow

Optional extras

The following items are available as optional extra:

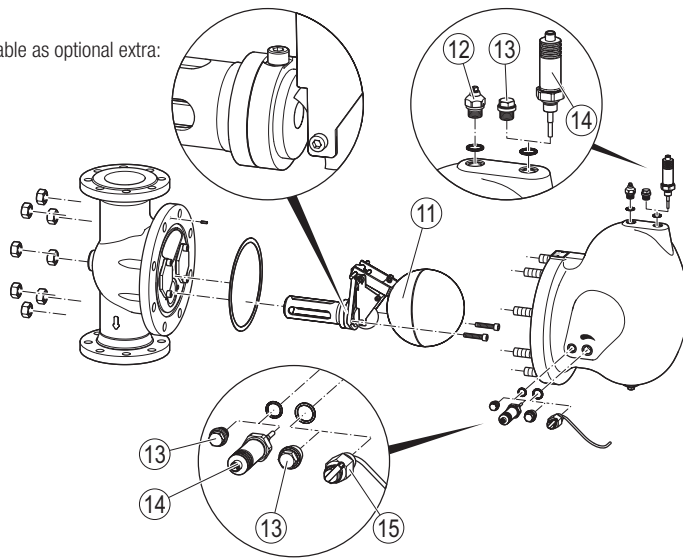

Item no.	Designation
11	Control unit SIMPLEX
12	Hand-vent valve with socket spanner (socket spanner not shown) The connection in the cover for the manual vent valve can also be used for fitting a balance pipe.
13	Sealing plug
14	Electrodes NRG 16-19 or NRG 16-27
15	Manual float-lifting lever

In equipment with control unit SIMPLEX the manual vent valve is included as standard.

Dimensions and weights

The drawing shows equipment with flanged ends for downward flow.

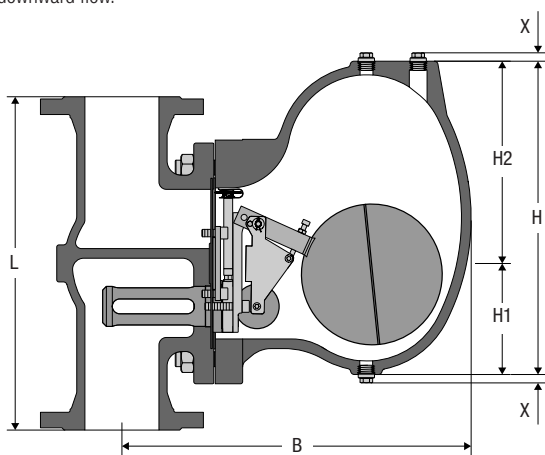

Space required for servicing

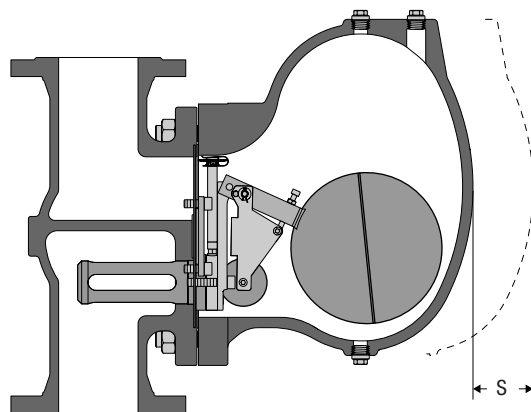

To remove the cover a withdrawal space S of 240 mm (9.4 in) is required.
If the supplied socket spanner or the lever extension is attached to the equipment an additional clearance of 150 mm (5.9 in) is required.

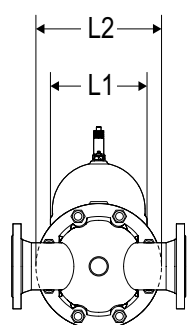

Direction of flow
horizontal

Dimensions and weights

DN 80 (3")

Abbreviation	End connection	[mm]	[""]
B	all	471	18.5
H1	all	150	5.9
H2	all	273	10.7
H	all	423	16.7
L1	all	250	9.8
L2	all	325	12.8
L	Flange to EN	450	17.7
	Flange to ASME, JIS	457	18.0
X	all	13	0.5
Weights		[kg]	[lb]
Weight	EN PN16/40, ASME CL 125/150, JIS 10K, JIS 20K	111	244.7
	UNA 46 ASME CL 300	114	251.3

DN 100 (4")

Abbreviation	End connection	[mm]	[""]
B	all	471	18.5
H1	all	150	5.9
H2	all	273	10.7
H	all	423	16.7
L1	all	250	9.8
L2	all	325	12.8
L	Flange to EN	450	17.7
	Flange to ASME, JIS	457	18.0
X	all	13	0.5
Weights		[kg]	[lb]
Weight	EN PN16/40, ASME CL 125/150, JIS 10K, JIS 20K	117	257.9
	UNA 46 ASME CL 300	125	275.6

DN 150 (6")

Abbreviation	End connection	[mm]	[""]
B	all	503	19.8
H1	all	150	5.9
H2	all	150	10.7
H	all	423	16.7
L1	all	250	9.8
L2	all	325	12.8
L	Flange to EN	500	19.7
	Flange to ASME, JIS	502	19.75
X	all	13	0.5
Weights		[kg]	[lb]
Weight	UNA 43 EN PN 16, ASME CL 125, JIS 10K	132	291.0
	UNA 46 EN PN 40, ASME CL 150, JIS 10K, JIS 20K	138	304.2
	UNA 46 ASME CL 300	150	330.7

Pressure and temperature ratings

Limiting conditions for UNA 43: Flange EN PN 16

Pressure ¹⁾ p	[barg]	16.0	14.4	12.8	12.3	11.2	9.6
Temperature ¹⁾ T	[°C]	-10/120	150	200	230	250	300
Max. admissible differential pressure Δ PMX	[barg]	2, 4, 8, 13					
Admissible service temperature	Control unit DUPLEX: Saturated steam temperature plus 5 K						

1) Pressure and temperature: Limit values for body/cover to EN 1092-2

Limiting conditions for UNA 43: Flange ASME CL 125

Pressure ¹⁾ p	[barg]	13.8	13.3	12.7	10.2	9.6	8.6
Temperature ¹⁾ T	[°C]	-29/65	80	100	180	200	232
Max. admissible differential pressure Δ PMX	[barg]	2, 4, 8, 13					
	[psi]	29, 58, 116, 188					
Admissible service temperature	Control unit DUPLEX: Saturated steam temperature plus 5 K						
Pressure ¹⁾ p	[psig]	200	190	180	145	130	125
Temperature ¹⁾ T	[°F]	-20/150	200	225	375	425	450

1) Pressure and temperature: Limit values for body/cover to ASME B16.1

Limiting conditions for UNA 43: Flange JIS 10K

Pressure ¹⁾ p	[barg]	14.0	14.0	10.0	–	–	–
Temperature ¹⁾ T	[°C]	-10/20	120	220	–	–	–
Max. admissible differential pressure Δ PMX	[barg]	2, 4, 8, 13					
Admissible service temperature	Control unit DUPLEX: Saturated steam temperature plus 5 K						

1) Pressure and temperature: Limit values for body/cover to JIS B2239

Limiting conditions for UNA 46: Flange EN PN 40

Pressure ¹⁾ p	[barg]	40.0	37.1	33.3	27.6	25.7	13.1
Temperature ¹⁾ T	[°C]	-10/20	100	200	300	350	450
Max. admissible differential pressure Δ PMX	[barg]	2, 4, 8, 13, 22, 32					
Admissible service temperature	Control unit DUPLEX: Saturated steam temperature plus 5 K						

1) Pressure and temperature: Limit values for body/cover to EN 1092-1

Limiting conditions for UNA 46: Flange ASME CL 150

Pressure ¹⁾ p	[barg]	19.6	17.7	13.8	10.2	8.4	5.5
Temperature ¹⁾ T	[°C]	-29/38	100	200	300	350	425
Max. admissible differential pressure Δ PMX	[barg]	2, 4, 8, 13, 22					
	[psi]	29, 58, 116, 188, 320					
Admissible service temperature	Control unit DUPLEX: Saturated steam temperature plus 5 K						
Pressure ¹⁾ p	[psig]	285	260	200	140	125	80
Temperature ¹⁾ T	[°F]	-20/100	200	400	600	650	800

1) Pressure and temperature: Limit values for body/cover to ASME B16.5

Limiting conditions for UNA 46: Flange ASME CL 300

Pressure ¹⁾ p	[barg]	51.1	46.6	43.8	39.8	37.6	28.8
Temperature ¹⁾ T	[°C]	-29/38	100	200	300	350	425
Max. admissible differential pressure Δ PMX	[barg]	2, 4, 8, 13, 22, 32, 40					
	[psi]	29, 58, 116, 188, 320, 465, 580					
Admissible service temperature	Control unit DUPLEX: Saturated steam temperature plus 5 K						
Pressure ¹⁾ p	[psig]	740	680	635	570	550	410
Temperature ¹⁾ T	[°F]	-20/100	200	400	600	650	800

1) Pressure and temperature: Limit values for body/cover to ASME B16.5

Limiting conditions for UNA 46: Flange JIS 10K

Pressure ¹⁾ p	[barg]	14	14	12	10	–	–
Temperature ¹⁾ T	[°C]	-10/20	120	220	300	–	–
Max. admissible differential pressure Δ PMX	[barg]	2, 4, 8, 13					
Admissible service temperature	Control unit DUPLEX: Saturated steam temperature plus 5 K						

1) Pressure and temperature: Limit values for body/cover to JIS B2220

Limiting conditions for UNA 46: Flange JIS 20K

Pressure ¹⁾ p	[barg]	34	31	29	26	23	20
Temperature ¹⁾ T	[°C]	-10/120	220	300	350	400	425
Max. admissible differential pressure Δ PMX	[barg]	2, 4, 8, 13, 22, 32					
Admissible service temperature	Control unit DUPLEX: Saturated steam temperature plus 5 K						

1) Pressure and temperature: Limit values for body/cover to JIS B2220

Capacity Chart

The chart shows the maximum capacities for hot condensate for the respective orifice.

The capacities are dependent on the differential pressure (working pressure).

The differential pressure is the difference between inlet and outlet pressure and depends among other things on the run of the condensate line. If the condensate downstream of the trap is lifted, the differential pressure is reduced by approximately 1 bar for 7 m lift.

The maximum admissible differential pressure is dependent on the cross-sectional area of the orifice and the density of the liquid.

These curves indicate the max. capacities of hot condensate that the steam traps UNA 43 and UNA 46 can discharge with virtually no banking up.

Cold water capacity: Capacity multiplied by factor F.

Capacity Chart

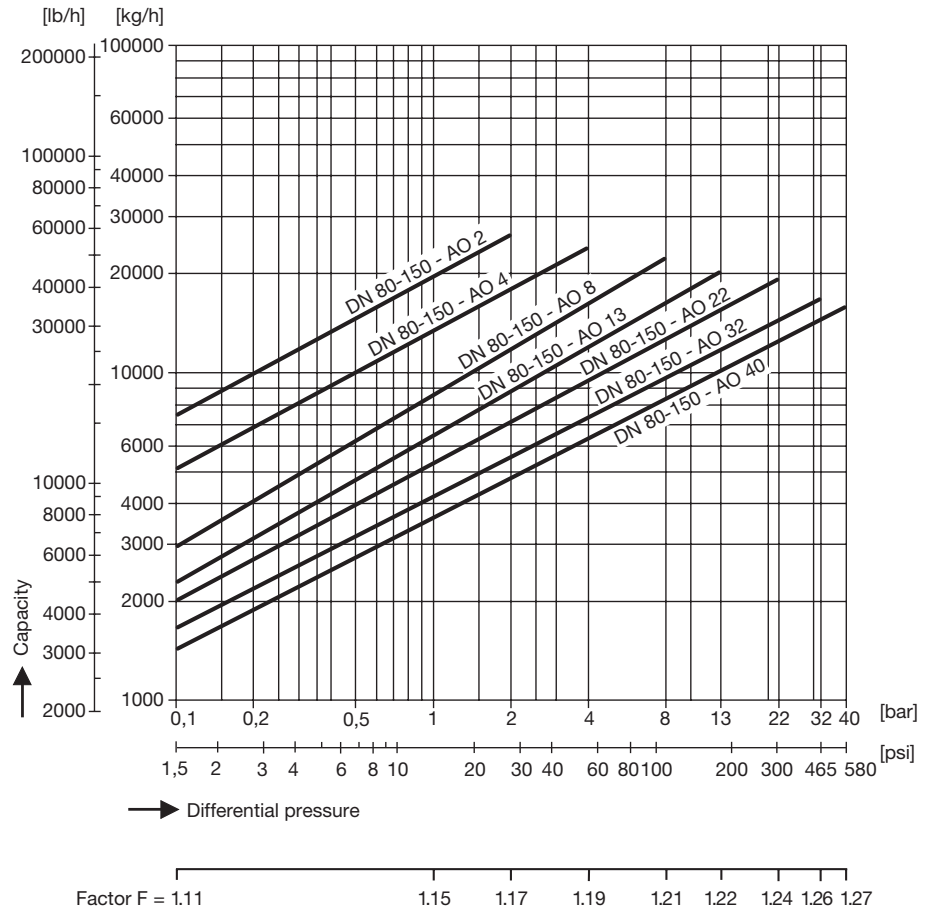

The max. differential pressure Δ PMX of the equipment depends on the type of orifice (O) used.

Orifice	Δ PMX [bar]	Diameter of bore [mm]
2	2	32.0
4	4	25.8
8	8	19.8
13	13	16.6
22	22	18.5
32	32	15.9
40	40	14.5

Ball Float Steam Trap
UNA 43 PN 16/CL 125/JIS 10K
UNA 46 PN 40/CL 150/CL 300/
JIS 10K/JIS 20K
DN 80, 100, 150, 3", 4", 6"

Inspection and Certification

Documentation regarding material tests and in-house examination with test report EN10204 available. All inspection requirements have to be stated with the enquiry or order. After supply of the equipment certification cannot be established. Charges and extent of the above mentioned test certificates as well as the different tests confirmed therein are listed in our Price List "Test and Inspection Charges for Standard Equipment". For other tests and inspections than those listed above, please consult us.

Application of European Directives

Pressure Equipment Directive (PED)

The equipment conforms to this directive and can be used for the following media:

UNA 43

Fluids of group 2

UNA 46

Fluids of group 1

Fluids of group 2

ATEX Directive

The equipment does not have its own potential ignition source and is not subject to this directive.

When installed, static electricity may arise between the equipment and the connected system.

When used in potentially explosive atmospheres, the plant manufacturer or plant operator is responsible for discharging or preventing possible static charge.

If it is possible for medium to escape, e.g. through actuating mechanisms or leaks in threaded joints, the plant manufacturer or plant operator must take this into consideration when dividing the area into zones.

Spare Parts

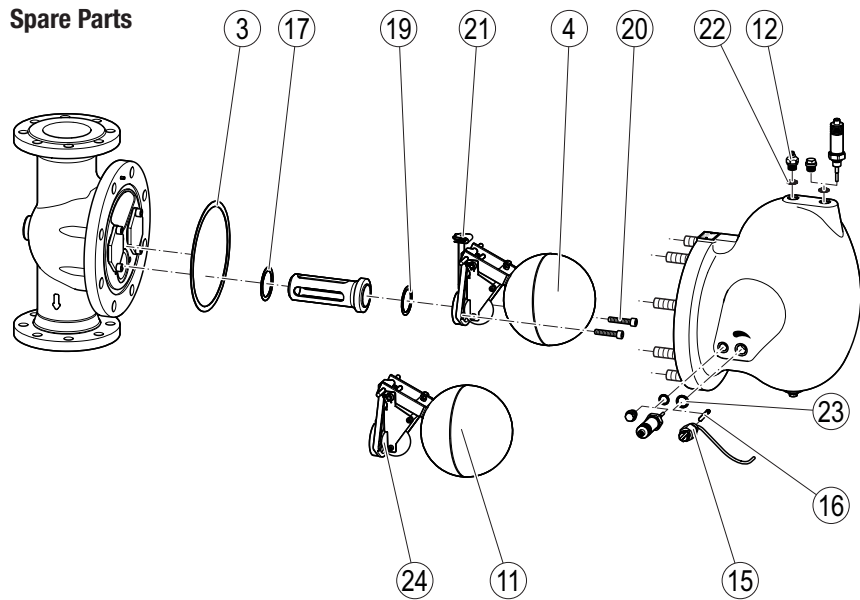

Item no.	Designation	Orifice	Stock code #	
			DUPLEX	SIMPLEX
3, 4/11, 17, 19, 20	Control unit including orifice, cpl. with body gasket, adapter gasket and gasket for control unit, socket-head cap screws	2	560720	560727
		4	560721	560728
		8	560722	560729
		13	560723	560730
		22	560724	560731
		32	560725	560732
3, 17, 19, 22, 23	Gasket set ¹⁾	all	560750	
		12, 22	Hand-vent valve, cpl. with joint ring and socket spanner	
15, 16, 23	Manual float lifting lever, cpl. with gasket and lever extension	all	560749	
3, 21	Membrane regulator capsule 5N2, cpl. with body gasket	all	560748	
24	Orifice	2	560734	560741
		4	560735	560742
		8	560736	560743
		13	560737	560744
		22	560738	560745
		32	560739	560746
40	560740	560747		
—	Socket spanner for hand vent valve	all	560700	

¹⁾ Contains:
 4 gaskets 3/8"
 1 gasket 3/4"
 1 body gasket
 1 gasket for control unit
 1 adapter gasket

Supply in accordance with our general terms of business.

GESTRA AG

Münchener Straße 77, 28215 Bremen, Germany
 Telefon +49 421 3503-0, Telefax +49 421 3503-393
 E-mail info@de.gestra.com, Web www.gestra.de

