

Steam Trap

# **BK 212 .. BK 212- ASME**

	Page
<b>Important Notes</b>	
Usage for the intended purpose .....	3
Safety note .....	3
Danger .....	3
Attention .....	3
Application of European Directives .....	3
Note on the Declaration of Conformity / Declaration by the Manufacturer .....	3
<b>Explanatory Notes</b>	
Scope of supply .....	4
Description .....	4
<b>Technical Data</b>	
Name plate / marking .....	4
<b>Design</b>	
BK 212 ..	5
BK 212-ASME .....	6
Key .....	7
<b>Installation</b>	
Attention .....	8
BK 212 ..	8
Installation instructions .....	8
Heat treatment of welds .....	8
<b>Commissioning Procedure</b>	
BK 212 ..	9
Danger .....	9
<b>Operation</b>	
Thermovit® regulator .....	9
<b>Maintenance</b>	
Cleaning / exchanging Thermovit® regulator and strainer .....	10
Tools .....	10
Torques .....	10
<b>Spare Parts</b>	
BK 212 ..	11
Spare parts list .....	1
<b>Decommissioning</b>	
Danger .....	11
Disposal .....	11

## Important Notes

### Usage for the intended purpose

Use steam traps BK 212 ..., BK 212-ASME only for the discharge of condensed water from steam lines or for air venting. Application in steam lines for the discharge of condensate only within the specified pressure and temperature ratings. Check corrosion resistance and chemical suitability for the application in question.

---

### Safety note

The equipment must only be installed and commissioned by qualified and competent staff. Retrofitting and maintenance work must only be performed by qualified staff who – through adequate training – have achieved a recognised level of competence.

---



#### Danger

The equipment is under pressure and hot during operation. Risk of severe injuries and burns to the whole body.

Installation and maintenance work should only be carried out when the installation is depressurized (0 bar) and cold (20° C).

The equipment must be isolated and vented from both upstream and downstream pressure before installation or maintenance work is performed.

Sharp edges on internals present the danger of cuts to hands.

Always wear industrial gloves when servicing the equipment.

---



#### Attention

The name plate specifies the technical features of the equipment. Do not commission or operate any item of equipment that does not bear its specific name plate.

The pressure and temperature ratings on the name plate of the equipment must meet the requirements of the installation.

---

## Application of European Directives

### Pressure Equipment Directive

The equipment conforms to this directive (see „Manufacturer's Declaration“ section) and can be used for the following media: ■ Fluids of group 2

### ATEX Directive

The equipment does not have its own potential ignition source and is not subject to this directive (see „Manufacturer's Declaration“ section).

When installed, static electricity may arise between the equipment and the connected system. When used in potentially explosive atmospheres, the plant manufacturer or plant operator is responsible for discharging or preventing possible static charge.

If it is possible for medium to escape, e.g. through actuating mechanisms or leaks in threaded joints, the plant manufacturer or plant operator must take this into consideration when dividing the area into zones.

---

## Note on the Declaration of Conformity / Declaration by the Manufacturer

For details on the conformity of our equipment according to the European Directives see our Declaration of Conformity or our Declaration of Manufacturer.

The current Declaration of Conformity / Declaration of Manufacturer are available in the Internet under [www.gestra.de/documents](http://www.gestra.de/documents) or can be requested from us.

## Explanatory Notes

### Scope of supply

**BK 212..., BK 212 ASME**

1 Steam trap BK 212

1 Installation manual

### Description

Thermostatic/thermodynamic steam trap with corrosion resistant Thermovit® regulator (bimetallic plates) able to withstand waterhammer. With internal strainer and integral non-return valve action. Asbestos-free body gasket (graphite/CrNi). Installation in any position.

The default factory setting enables the steam trap to discharge condensate with virtually no banking-up.

## Technical Data

### Name plate / marking

The temperature/pressure ratings are indicated on the body or on the name plate. For more information see GESTRA technical documents such as data sheets and the Technical Information.

The name plate or the body indicates the type and design:

- Name/logo of the manufacturer
- Type designation / material number
- Pressure class PN or Class
- Material number
- Max. temperature
- Max. pressure
- Direction of flow
- Stamp on equipment body / name plate, e.  $g \frac{1}{10}$  specifies the quarter and the year of production (example: 1<sup>st</sup> quarter 2010)

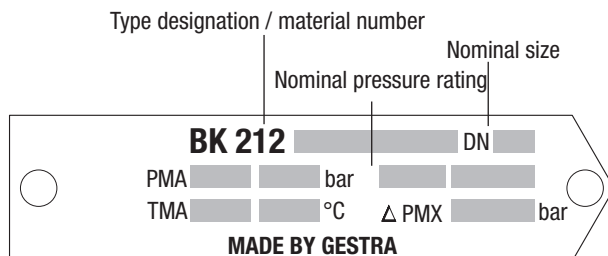

Fig. 1

Component parts BK 212 ..

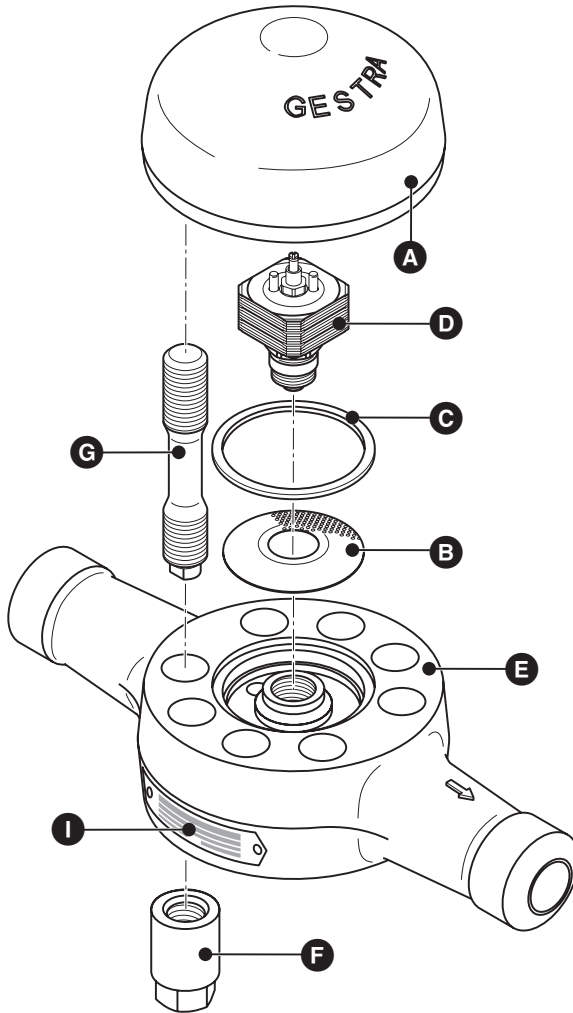

Fig. 2

### Component parts BK 212-ASME

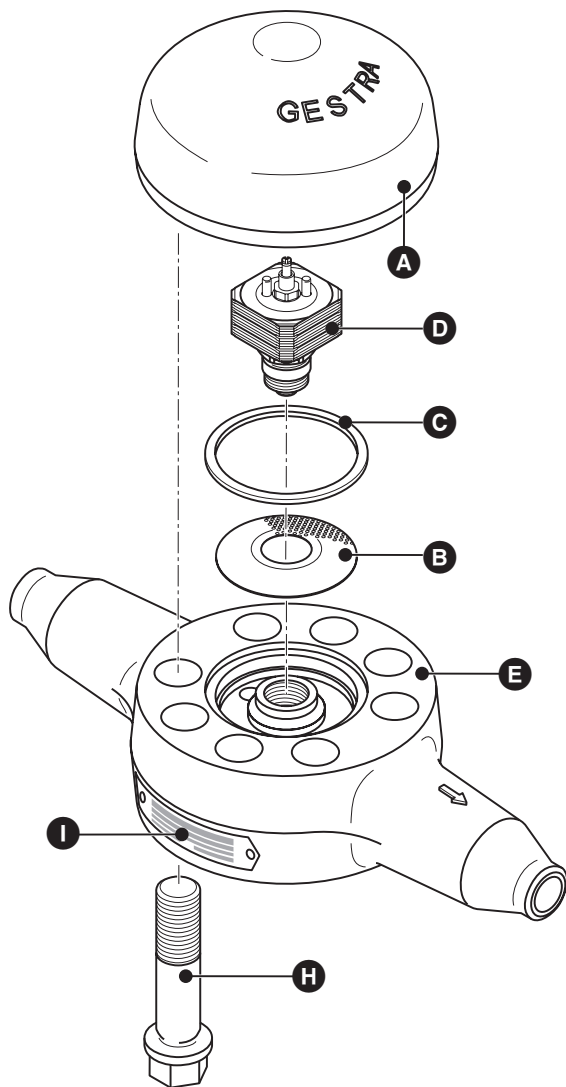

Fig. 3

## **Key**

- A** Cover
- B** Strainer
- C** Gasket
- D** Thermovit®- regulator
- E** Body
- F** Cap nut
- G** Expansion bolt with reduced shank to DIN 2510
- H** Set screws with collar
- I** Name plate

## Installation



### Attention

- The nominal size of this equipment is designed for DN 25. Note that the admissible loads (forces, torques) acting on pipe connections with end connections larger than DN 25 are limited to the permissible pipe end loads of a size DN 25 device. Should the pipe end connection loads exceed this limit, take appropriate measures to provide additional support so as to protect the equipment.
- Welded trap installation should only be performed by qualified welders (certified according to DIN EN 287 or equivalent).
- We recommend not to insulate the steam trap.

---

The equipment must be installed so that the flow arrow on the body is pointing in the same direction as the steam flow. Preferred installation of the equipment in horizontal lines with cover at the top.

---

### Installation instructions

1. Make sure that the flow arrow on the equipment body matches the direction of flow of the steam.
2. Consider space required for servicing the equipment. When the equipment is installed a minimum space of at least **150 mm** (BK 212 ..) or **70 mm** (BK 212-ASME) is required for removing the cover **A**.
3. Remove plastic plugs. They are **only** used for transit protection.
4. Clean end connections.
  - 5.1 Install equipment with releasable end connections (e. g. flanges).
  - 5.2 For equipment with socket-weld ends or butt-weld ends: Apply arc welding processes 111 and 141 according to ISO 4063 (or equivalent standard).

### Heat treatment of welds

After welding the steam trap in place a heat treatment of the welds is required (stress-relief annealing to DIN EN 100529). The heat treatment must be restricted to the immediate area of the weld.



## Commissioning Procedure

Make sure that all connections are subjected to a suitable pressure test according to the pertinent rules and regulations.



### Danger

The equipment is under pressure and hot during operation. Risk of severe injuries and burns to the whole body.

Installation and maintenance work should only be carried out when the installation is depressurized (0 bar) and cold (20° C).

The equipment must be isolated and vented from both upstream and downstream pressure before installation or maintenance work is performed.

Sharp edges on internals present the danger of cuts to hands.  
Always wear industrial gloves when servicing the equipment.

## Operation

### Thermovit® regulator

The factory setting of the Thermovit® regulator ensures that the equipment is steam-tight when closed and opens just before the pressure-dependent boiling temperature is reached.

Periodic testing and maintenance of the equipment is recommended to ensure proper functioning. Continuous monitoring is recommended for critical applications.

### Cleaning / exchanging Thermovit® regulator and strainer

1. Remove cover **A** from body **E**. Fig. 2, Fig. 3
2. Remove Thermovit® regulator **D** using an open-end spanner (US: wrench).
3. Unscrew Thermovit® regulator **D** and take off strainer **B**.
4. Clean body, regulator, cover and strainer.
5. Clean sealing surfaces and insert new gasket **C**.
6. Clean seating surfaces of body **E** and Thermovit® regulator **D**.
7. Clean and insert strainer **B**.
8. Mount regulator **D** and tighten it with a torque of **100 Nm**.
9. Apply heat-resistant lubricant (e. g. OKS 217®) to expansion bolt with reduced shank **G**.
10. Replace cover **A**, insert expansion bolts with reduced shank **G**, mount cap nuts **F** and tighten them with the torque indicated in the table below in diagonally opposite pairs.
11. Replace cover **A**, insert set screw with collar **H** (ASME design) and tighten it with **225 Nm** in diagonally opposite pairs.

### Tools

- Combination spanner A. F. 11 mm, DIN 3113, form B
- Combination spanner A. F. 24 mm, DIN 3113, form B
- Torque spanner (US: torque wrench) 6 - 50 Nm, ISO 6789
- Torque spanner (US: torque wrench) 80 - 400 Nm, ISO 6789

### Torques

Item	Designation	Torque [Nm]	
		BK 212, BK 212-S, BK 212-F91, BK 212-ASME	BK 212-F91-SD, BK 212-F92-SD
<b>D</b>	Thermovit® regulator	100	100
<b>G</b>	Stud bolt with reduced shank	20	20
<b>F</b>	Cap nut	225	275
<b>H</b>	Set screw with collar	225	–

All torques indicated in the table are based at a room temperature of 20 °C.

## Spare Parts

### BK 212 .., BK 212-ASME

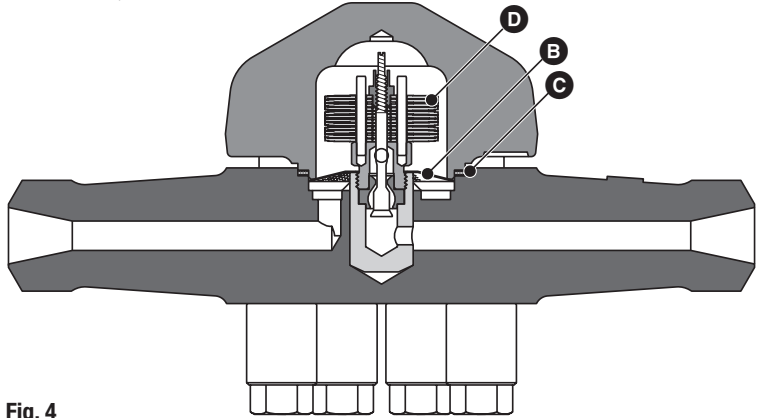

Fig. 4

### Spare parts list

Item	Designation	Stock code #	
		BK 212, BK 212-S, BK 212-F91, BK 212-ASME	BK 212-F91-SD, BK 212-F92-SD
<b>D</b> <b>C</b>	Thermovit® regulator, complete, including gasket	371862	451327
<b>C</b>	Gasket (graphite/1.7335)	451404	451550
<b>B</b> <b>C</b>	Strainer	451428	451551

## Decommissioning



### Danger

The equipment is under pressure and hot during operation. Risk of severe injuries and burns to the whole body.

Installation and maintenance work should only be carried out when the installation is depressurized (0 bar) and cold (20° C).

The equipment must be isolated and vented from both upstream and downstream pressure before installation or maintenance work is performed.

Sharp edges on internals present the danger of cuts to hands.

Always wear industrial gloves when servicing the equipment.

### Disposal

For the disposal of the equipment observe the pertinent legal regulations concerning waste disposal.



Agencies all over the world: [www.gestra.com](http://www.gestra.com)

## **GESTRA AG**

Münchener Straße 77

28215 Bremen

Germany

Telefon +49 421 3503-0

Telefax +49 421 3503-393

E-mail [info@de.gestra.com](mailto:info@de.gestra.com)

Web [www.gestra.de](http://www.gestra.de)