

# HAD

## SHELL & COIL HEAT EXCHANGERS



# HAD HEAT EXCHANGERS

HAD shell and coil exchanger is a fully equipped, installation-ready kit consisting of an exchanger, mount and insulation.

As a result of advanced design works, HAD has all the benefits of the shell and coil exchangers plus new solutions such as the horizontal position of the connections; it also comes with an insulation and a mount.

The new HAD features facilitate mounting it to a horizontal installation and shorten the whole process. Additionally HAD is a perfect solution in terms of economy, ensuring a cost-efficient solution.



## WHY CHOOSE **HEXONIC** HAD SHELL & COIL HEAT EXCHANGERS?



COMPACT SIZE



LARGE HEAT EXCHANGE AREA



LOW MAINTENANCE COSTS



RESISTANCE TO HIGH TEMPERATURE AND PRESSURE



HIGH PERFORMANCE



FACTORY-INSTALLED INSULATION



TURBULENT FLOW PROMOTED BY CORRUGATION OF TUBES



VERTICAL INSTALLATION REDUCES SPACE REQUIREMENTS



MANUFACTURED IN ACCORDANCE WITH PED, ASME



USER-FRIENDLY CAIRO SELECTION SOFTWARE MAKES THE SELECTION PROCESS EASY



WIDE RANGE OF PRODUCTS



# HAD CONSTRUCTION

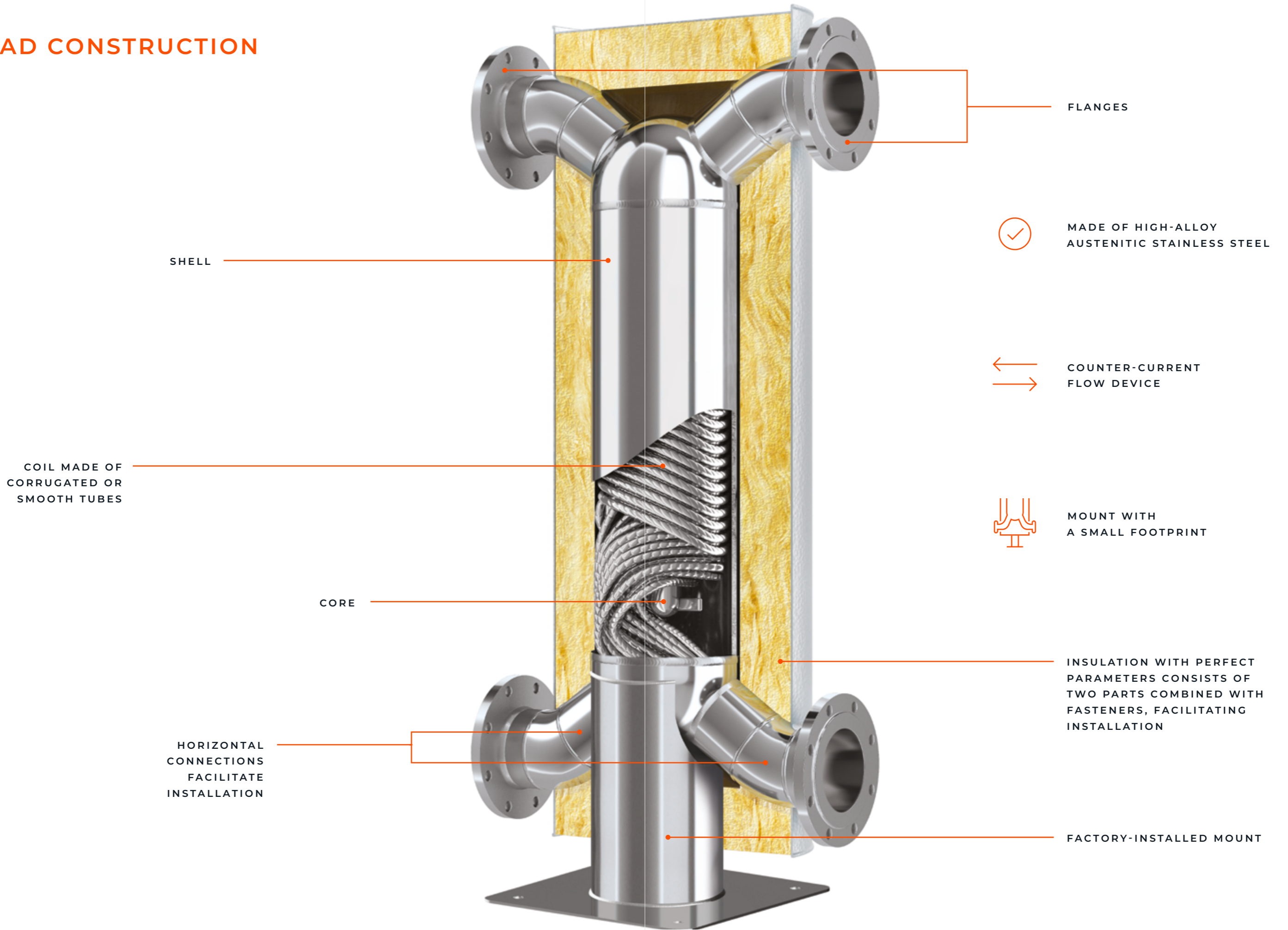



APPLICATION



HVAC SYSTEMS



STEAM APPLICATIONS



HEATING AND COOLING SYSTEMS



HEAT TRANSFER IN INDUSTRIAL PROCESSES



OIL COOLERS

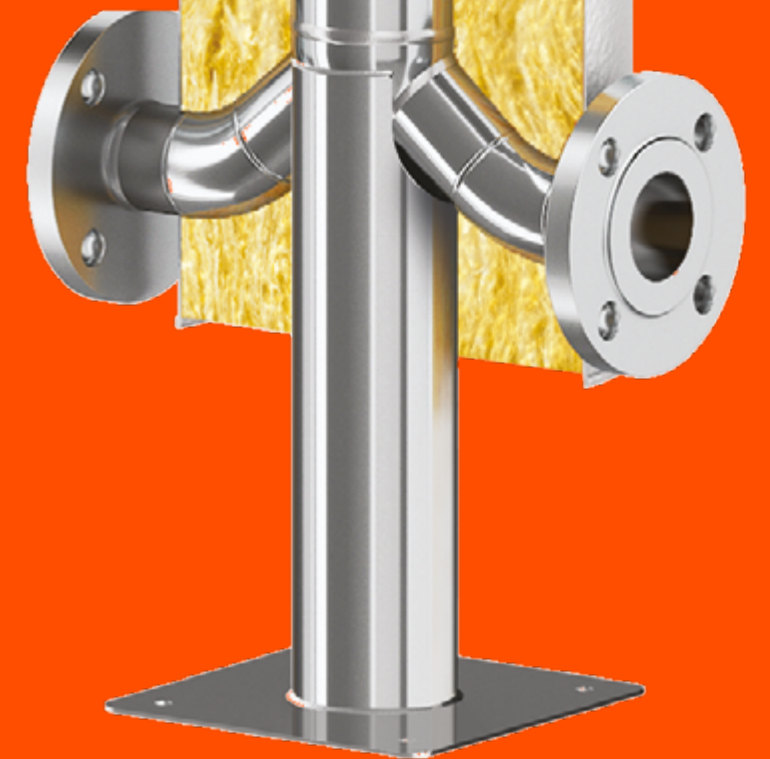



# TECHNICAL DATA

## STANDARD LOCATION OF CONNECTIONS

- K1 / K4 — inlet / outlet hot side
- K3 / K2 — inlet / outlet cold side

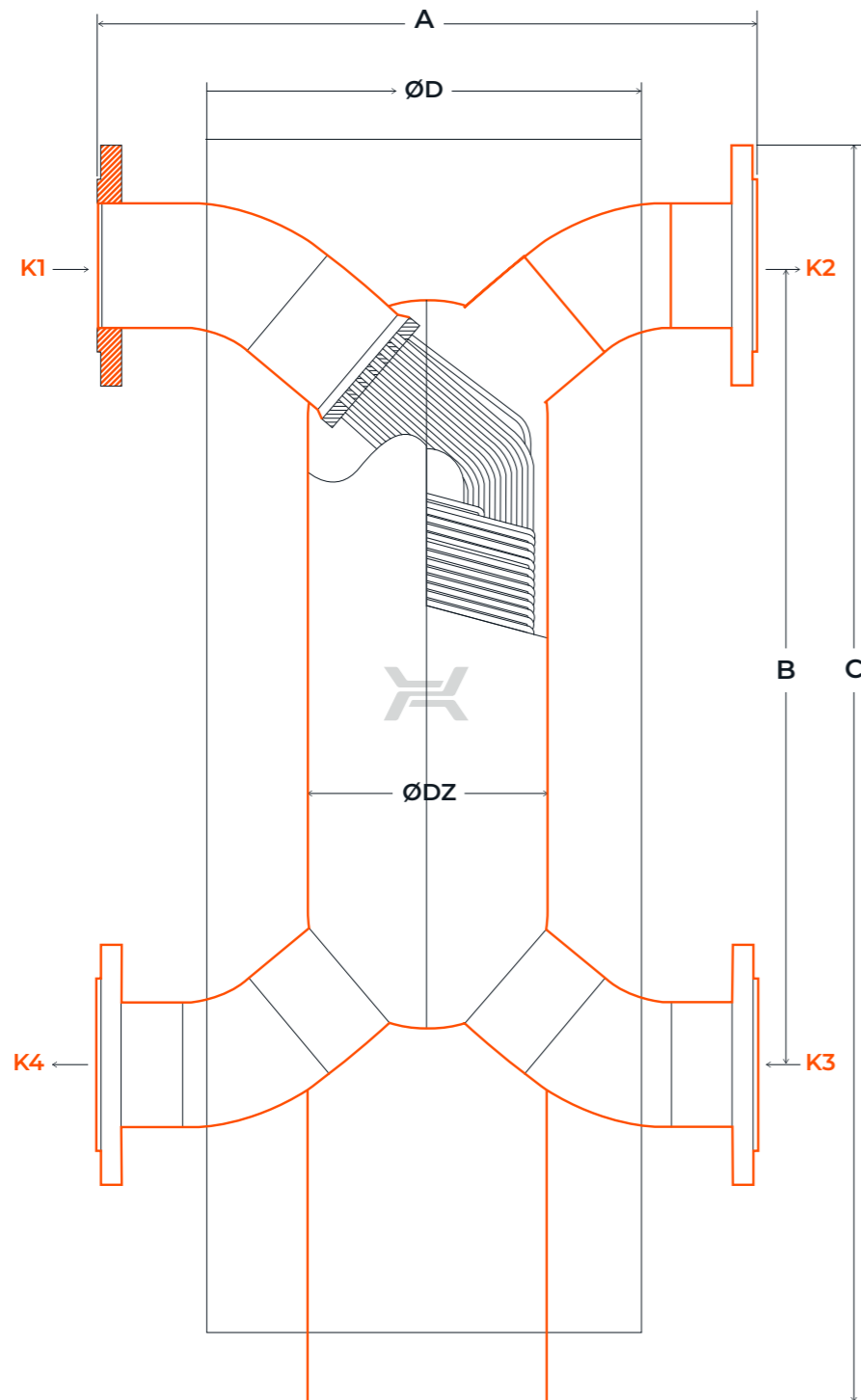

## MATERIALS

- STAINLESS STEEL
- FLANGES – STAINLESS STEEL (SS)  
OR CARBON STEEL (CS)

## EXEMPLARY MEDIA

- WATER
- PROPYLENE GLYCOL
- GROUP II FLUIDS
- OTHER

## WORKING PARAMETERS

### TUBES

- MAX. TEMPERATURE
- F — 200°C / 392°F
  - M — 250°C / 482°F
  - B — 200°C / 392°F

### MAX. PRESSURE

- F — 16 BAR / 232 PSI
- M — 25 BAR / 363 PSI
- B — 35 BAR / 507 PSI

### SHELL

- MAX. TEMPERATURE  
(F, M, B) — 200°C / 392°F

### MAX. PRESSURE

- (F, M, B) — 16 BAR / 232 PSI

# TECHNICAL PARAMETERS

Type	Dimensions										Heat exchange area		Tube diameter		Weight		Tube side capacity		Shell side capacity	
	A		B		C		D		ØDz		m <sup>2</sup>	ft <sup>2</sup>	mm	in	kg	lb	l	gal	l	gal
	mm	in	mm	in	mm	in	mm	in	mm	in										
HAD 50	401	15.8	938	36.9	1168	46	300	11.8	139,7	5.5	2,3	24.8	8	0.3	35	77.2	3,6	1	6,5	1.7
HAD 51	403	15.9	1020	40.2	1250	49.2	320	12.6	159	6.3	3,1	33.4	8	0.3	42	92.6	4,6	1.2	9,9	2.6
HAD 2.11.08.68	349	13.7	852	33.5	1088	42.8	245	9.7	80	3.2	0,6	6.5	8	0.3	25,6	56.4	1,8	0.5	2,5	0.7
HAD 2.11	349	13.7	1534	60.4	1770	69.7	245	9.7	80	3.2	1,2	12.9	8	0.3	36	79.4	2,8	0.7	3,5	0.9
HAD 3.18.08.75	384	15.1	948	37.3	1213	47.8	265	10.4	101,6	4	1	10.8	8	0.3	31,5	69.5	3,3	0.9	4,4	1.2
HAD 3.18	384	15.1	1540	60.6	1805	71	265	10.4	101,6	4	2	21.5	8	0.3	44,6	98.3	4,7	1.2	6,9	1.8
HAD 5.38.08.71	450	17.7	944	37.2	1249	49.2	305	12	139,7	5.5	2,3	24.8	8	0.3	47,6	104.9	6,6	1.7	8,9	2.4
HAD 5.38	450	17.7	1544	60.8	1849	72.8	305	12	139,7	5.5	4,3	46.3	8	0.3	66	145.5	9,5	2.5	12,8	3.4
HAD 6.50.08.72	497	19.6	960	37.8	1308	51.5	320	12.6	159	6.3	3	32.3	8	0.3	57	125.7	9,2	2.4	14	3.7
HAD 6.50	497	19.6	1545	60.8	1893	74.5	320	12.6	159	6.3	5,5	59.2	8	0.3	78,5	173.1	12,9	3.4	19,1	5.1
HAD 6.50.10	497	19.6	1545	60.8	1893	74.5	320	12.6	159	6.3	4,7	50.6	10	0.4	74,9	165.1	13,9	3.7	18,5	4.9
HAD 9.88.08.65	604	23.8	956	37.6	1376	54.2	385	15.2	219,1	8.6	4,9	52.7	8	0.3	81,8	180.3	16,8	4.4	29,1	7.7
HAD 9.88.08.85	604	23.8	1156	45.5	1576	62	385	15.2	219,1	8.6	6,3	67.8	8	0.3	95	209.4	18,8	5	33,4	8.8
HAD 9.88	604	23.8	1552	61.1	1972	77.6	385	15.2	219,1	8.6	10,6	114.1	8	0.3	120,6	265.9	25	6.6	38,3	10.1
HAD 9.88.10	604	23.8	1552	61.1	1972	77.6	385	15.2	219,1	8.6	7,7	82.9	10	0.4	110,8	244.3	24,6	6.5	36,5	9.6
HAD 12.114.08.50	670	26.4	834	32.8	1272	50.1	435	17.1	273	10.8	5,8	62.4	8	0.3	100,6	221.8	23,4	6.2	43	11.4
HAD 12.114.08.60	670	26.4	934	36.8	1372	54	435	17.1	273	10.8	6,4	68.9	8	0.3	107,1	236.1	24,2	6.4	47,3	12.5
HAD 12.114.08.75	670	26.4	1084	42.7	1522	59.9	435	17.1	273	10.8	8,8	94.7	8	0.3	123,3	271.8	27,7	7.3	50,7	13.4
HAD 12.114	670	26.4	1736	68.4	2174	85.6	435	17.1	273	10.8	18,2	195.8	8	0.3	187,8	414	41,4	10.9	67,6	17.9
HAD 12.114.10	670	26.4	1736	68.4	2174	85.6	435	17.1	273	10.8	18,6	200.1	10	0.4	193,8	427.3	51,1	13.5	53,2	14.1

All dimensions and technical data are approximate only and may be changed without further notice.

## CONNECTIONS

Type	Connection
HAD 50	DN40
HAD 51	DN40
HAD 2.11.08.68	DN40
HAD 2.11	DN40
HAD 3.18.08.75	DN50
HAD 3.18	DN50
HAD 5.38.08.71	DN65
HAD 5.38	DN65
HAD 6.50.08.72	DN80
HAD 6.50	DN80
HAD 6.50.10	DN80
HAD 9.88.08.65	DN100
HAD 9.88.08.85	DN100
HAD 9.88	DN100
HAD 9.88.10	DN100
HAD 12.114.08.50	DN125
HAD 12.114.08.60	DN125
HAD 12.114.08.75	DN125
HAD 12.114	DN125
HAD 12.114.10	DN125

\* Flanges: EN 1092-1 for PED 2014/68/EU certified hex and ASME B 16.5 for ASME certified hex

## INSULATION AMWI

### MINERAL WOOL INSULATION COVERED WITH ALUMINIUM

- MAX. WORKING TEMPERATURE: 482 °F / 250 °C
- THICKNESS: 3.15 IN / 80 MM
- THERMAL CONDUCTIVITY AT MAX. TEMPERATURE: 0.474 BTU/FT. HOUR °F / 0,082 W/MK



## EXEMPLAR DESIGNATION

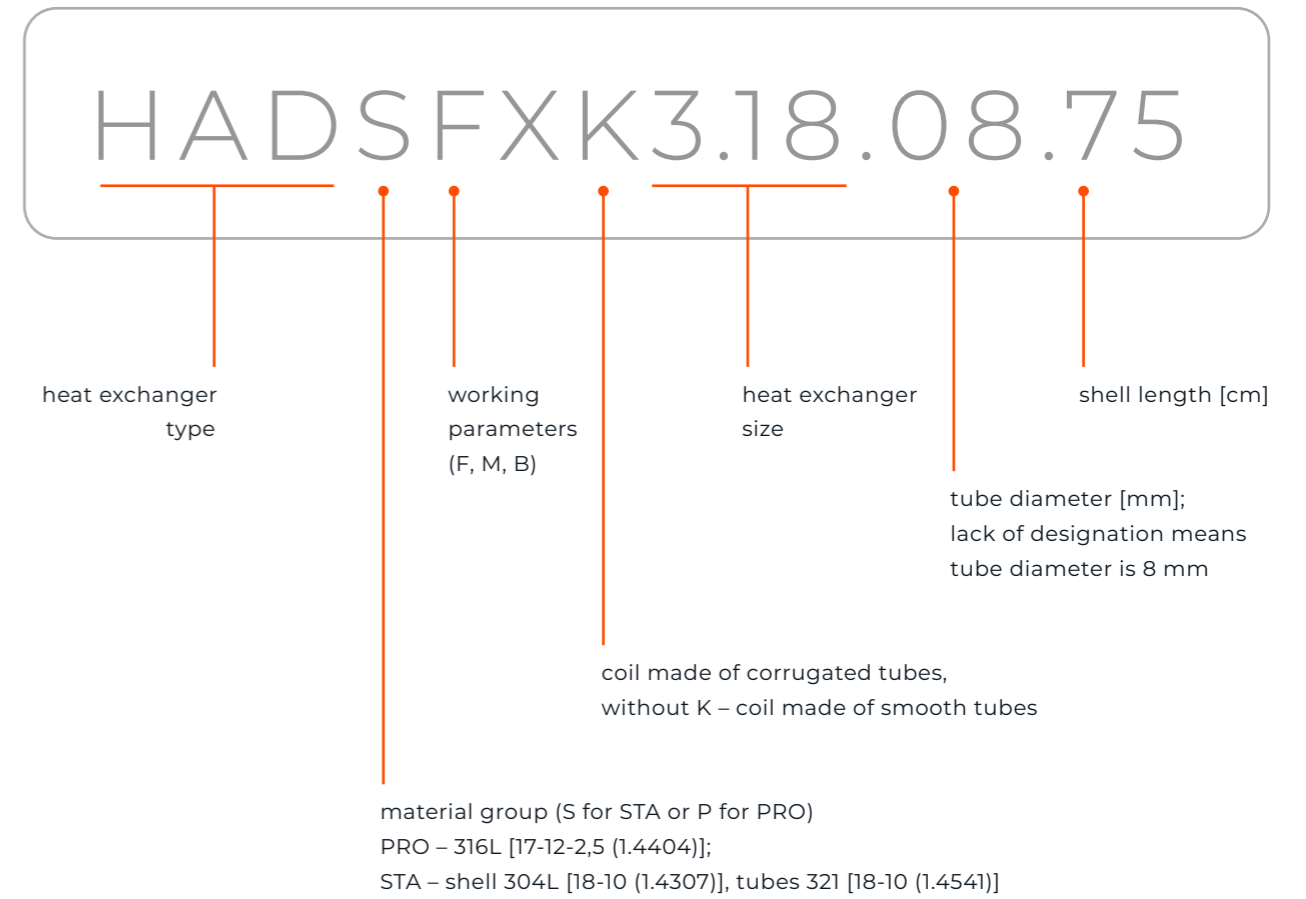

## PRODUCT LINE



hexonic.com

**alnab**

EN.ver.1.2022

Alnab Armatur AB  
Ögärdesvägen 4B  
SE-433 30 Partille

Websida: [www.alnab.se](http://www.alnab.se)  
Tel: +46(0)31-449450

ver 1 2022