

Digital Electro-Pneumatic Positioner
baelz 87



Operating Instructions**OI 87****Table of contents**

1. SAFETY	4
1.1 Intended use	4
1.2 For the operator	4
1.3 Personnel	5
1.4 Before starting work	5
1.5 During operation	5
1.5.1 Transport, installation and mounting	5
1.5.2 Service and maintenance	5
1.5.3 Servicing explosion-protected devices	5
1.5.4 Prevention of hazards	6
1.6 Working environment	6
2. PRODUCT DESCRIPTION	7
2.1 Identification	7
2.2 Article code and explosion protection certificates	7
2.3 Specifications	8
2.4 Design and principle of operation	9
2.4.1 Tight-closing function	9
2.4.2 Direction of control action	9
2.5 Accessories	11
2.6 Operating conditions	11
3. TRANSPORT AND STORAGE	12
4. MOUNTING	12
4.1 Positioner mounting	12
4.1.1 Mounting with yoke S21 / S21-L	12
4.1.2 Mounting with yoke S41	12
4.2 Pneumatic connection	16
4.2.1 Supply pressure	17
4.3 Electrical connection	18
4.3.1 Electric power supply	18
4.3.2 Selecting cables and wires	18
4.3.3 Wiring	18
5. OPERATION	20
5.1 Operating controls	20
5.1.1 Capacitive keys	20
5.1.2 Volume restriction Q	20
5.1.3 Display	21

Operating Instructions

OI 87

6. OPERATING THE POSITIONER	22
6.1 Adapting the display	23
6.2 Enabling configuration to change parameters	23
6.3 Adjusting the volume restriction Q	24
6.4 Entering the direction of control action	25
6.5 Entering the direction of motion	25
6.6 Limiting the pneumatic signal	26
6.7 Setting other parameters	26
6.8 Initialisation	27
6.8.1 Stopping initialisation	28
6.9 Zero calibration	28
6.9.1 Stopping zero calibration	29
6.10 Manual operation	29
6.11 Reset	30
7. MALFUNCTIONS	31
7.1 Resetting error codes	32
7.2 Error codes	32
7.3 Emergency action	32
7.4 Error codes	33
8. CODE LIST	34
8.1 Parameter code table	34
8.2 Label on the inside of the cover	35
9. SPARE PARTS	36
10. DECOMMISSIONING AND DISPOSAL	36
10.1 Decommissioning	36
10.2 Disassembling the positioner	36
10.3 Disposal	36
11. DIMENSIONS AND MOUNTING EXAMPLES	37
11.1 Dimensions Baelz 87	37
11.2 Baelz 87 mounted to Baelz 373 P21/P21-V6/P22 actuators	38
11.3 Baelz 87 mounted to Baelz 373 P21/P21-V6/P22 actuators	39

BA_87_02_EN_MJ_4017

1. SAFETY

Carefully read these operating Instructions, especially the following safety precautions prior to installation and operation.

**Caution****Caution**

Potentially hazardous situation which could result in minor injury.
Also indicates a risk which may cause material damage.

**Attention****Attention**

Potentially harmful situation which can result in damage to the product or an object in its environment.

**Danger****Danger**

Imminently hazardous situation which is likely to result in death or serious injury.

**Warning****Warning**

Potentially hazardous situation which may result in death or serious injury.

**Tip:**

Instructions for use or other useful information.

**Info:**

Additional information.

1.1 Intended use

The electro-pneumatic positioner type baelz 87 can be fitted to a pneumatic actuator and is used to set the position of the valve according to the control signal.

To ensure use for the purpose intended, check that the above type identification corresponds to the name plate on the positioner before starting any activities. The actual technical data of the positioner and the power supply requirements are the specifications indicated on the name plate.

Any use other than the intended use mentioned above, different tasks, and operation with other power sources than those permitted, is considered to be improper use. In case of improper use, the operator shall be solely liable for the risk presented to persons and the device as well as to other property!

The intended use also comprises compliance with the accident prevention regulations and the DIN VDE standards of the German Institute for Standardization and the Association for Electrical, Electronic & Information Technologies. It also implies working in accordance with the safety requirements when performing all activities described in these operating instructions, under consideration of general technical rules and regulations.

1.2 For the operator

Always keep the operating instructions available and easily accessible at the site of operation of the positioner!

During set-up and operation and when performing maintenance procedures on the device, observe relevant occupational safety regulations, accident prevention regulations and the DIN VDE standards of the German Institute for Standardization and the Association for Electrical, Electronic & Information Technologies. Ensure compliance with any additional regional, local or in-house safety regulations applicable.

Make sure that any person assigned by you to perform the activities described in these operating Instructions has read and understood these instructions.

1.3 Personnel

Only qualified personnel may operate this positioner or work in its vicinity. Qualified personnel are individuals who are familiar with the set-up, installation, commissioning, operation and maintenance of the positioner and possess the required qualification for their activity. The required or prescribed qualifications include, amongst others:

- Training / instruction and the authorization to switch electric circuits and devices / systems on and off in accordance with EN 60204 (DIN VDE 0100 / 0113) and the technical safety standards.
- Training or instruction in accordance with the technical safety standards for the maintenance and use of appropriate safety equipment and personal protective equipment.
- Explosion-protected versions of this device are to be operated only by personnel having undergone special training or instructions or being authorized to work on explosion-protected devices in hazardous areas.
- First aid training.

Always work safely and never perform any work which might present a hazard to persons or damage the actuator or other property in any way.

1.4 Before starting work

Prior to starting any kind of work, check that the types specified here are identical with the specifications on the name plate of the positioner: **Baelz 87**

1.5 During operation

Safe operation can only be ensured if transport, storage, assembly, operation and maintenance procedures are performed in compliance with the safety requirements, and are performed properly and competently.

1.5.1 Transport, installation and mounting

Observe the general installation and safety regulations for heating, ventilating, air conditioning and piping. Use tools properly and competently. Wear the required personal and other protective equipment.

1.5.2 Service and maintenance

Prior to maintenance or repair, make sure that the positioner is disconnected from the power supply by qualified personnel in accordance with DIN VDE standards. The positioner requires no maintenance. We recommend, however, to check the proper function of the positioner at least once a year.

There are filters with a 100 µm mesh size in the pneumatic connections for supply and output which can be removed and cleaned, if required.

→ Observe the maintenance instructions of any upstream supply air pressure reducing stations.

1.5.3 Servicing explosion-protected devices

If a part of the device relevant to explosion protection needs to be serviced, the device must not be put back into operation until a qualified inspector has assessed it according to explosion protection requirements, has issued an inspection certificate, or given the device the mark of conformity.

Inspection by a qualified inspector is not required if the manufacturer performs testing to explosion protection standards on the device before recommissioning it and a mark of conformity has been attached to confirm that these tests have been successfully passed.

Replace explosion-protected components only with the manufacturer's original, individually tested components.

**Attention**

Devices that have already been operated outside hazardous areas and are intended for future use inside hazardous areas must comply with the safety requirements applicable for serviced devices. Before being operated inside hazardous areas, test the devices according to the specifications for servicing explosion-protected devices.

1.5.4 Prevention of hazards

Hazards that could be caused at the valve by the process medium, pneumatic pressure and moving parts must be prevented.

If excessive motion or forces occur in the pneumatic actuator as a result of the supply pressure level, this supply pressure must be restricted using a suitable pressure reducing station.

1.6 Working environment

Please observe the information regarding the working environment given in the specifications.

2. PRODUCT DESCRIPTION

2.1 Identification

Each positioner 87 has a name plate. This plate includes specifications regarding the operating conditions of the device and the manufacturer's device and serial number.

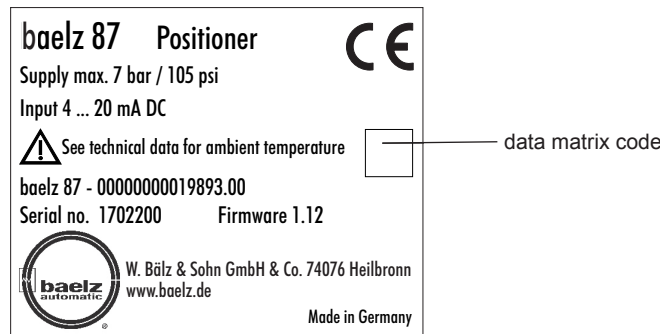

Fig. 1: Baelz positioner name plate

2.2 Article code and explosion protection certificates

Article code on the name plate

Positioner	baelz 87-	x	x	x
With LCD and autotune, 4 to 20 mA reference variable				
Explosion protection				
baelz 87 (none)		0	0	0
baelz 87-Ex		1	1	0
baelz 87-Ex-CSA		1	3	0
baelz 87-Ex-GOST		1	1	3

Summary of explosion protection certificates

Type	Certification			Type of protection
baelz 87-Ex	STCC	Number	No. 2860	0 Ex ia IIC T4 X
		Valid until	08.10.2017	
baelz 87-Ex-GOST		Number	PTB 11 ATEX 2020 X	II 2 G Ex ia IIC T4
		Date	25.08.2011	
baelz 87-Ex-GOST		Number	RU C-DE. GB08.B.00697	1Ex ia IIC T4 Gb X
		Date	15.12.2014	
		Valid until	14.12.2019	
baelz 87-Ex-CSA		Number	2703735 X	Ex ia IIC T4; Class I, Zone 0, AEx ia IIC T4; Class I, Div. 1, Groups A, B, C & D
		Date	03.06.2014	

Fig. 2: Tables: Article code and summary of explosion protection certificates

Operating Instructions

OI 87

2.3 Specifications

Positioner baelz 87	
Stroke	max. 66 mm
Reference variable w (reverse polarity protection) Destruction limit	4 to 20 mA signal range · Two-wire device, Split-range operation 4 to 11.9 mA and 12.1 to 20 mA ±33 V
Minimum current	3.8 mA
Load impedance	max. 6.3 V
Supply air Air quality acc. to ISO 8573-1	Supply air: 1.4 to 7 bar (20 to 105 psi), max. particle size and density: class 4, oil content: class 3, pressure dew point: class 3 or at least 10 K below the lowest ambient temperature to be expected
Pneumatic signal (output)	0 bar up to the supply pressure, can be limited to approx. 2.3 bar by software
Characteristic	Selection: 3 stroke characteristics
Hysteresis	≤ 0.3 %
Sensitivity	≤ 0.1 %
Run time	Only for actuators with initialisation time > 0.5 s. (for faster actuators use a volume restriction to prevent an initialisation failure)
Direction of motion	w/x reversible
Air consumption	≤ 100 l _n /h with a supply pressure up to 6 bar and a signal pressure of 0.6 bar
Air supply To fill actuator with air To vent actuator	At Δp =6 bar: 8.5 m _n ³ /h, At Δp =1.4 bar: 3.0 m _n ³ /h, K _{vmax} (20°C) = 0.09 At Δp =6 bar: 14.0 m _n ³ /h, At Δp =1.4 bar: 4.5 m _n ³ /h, K _{vmax} (20°C) = 0.15
Permissible ambient temperature	-20 to +80 °C or -25 to +80 °C with metal cable gland For explosion-protected versions, the limits in the test certificates apply additionally.
Safety	
Influences	Temperature: ≤ 0.15 %/10 K Effect of vibration: ≤ 0.25 % up to 2000 Hz and 4 g according to IEC 770 Auxiliary energy: None
Electromagnetic compatibility	Complying with EN 61000-6-2, EN 61000-6-3 and NE 21.
Explosion protection	Intrinsic safety: ATEX, STCC, CSA, GOST (cf. table Fig. 2, page 7)
Protection rating	IP 66
Compliance	CE
Materials	
Housing	Polyphthalamide (PPA)
Cover	Polycarbonate (PC)
External parts	Stainless steel 1.4571 and 1.4301
Cable gland	Black polyamide (PA), M20 x 1.5
Vent plugs	High-density polyethylene (PE-HD)
Weight	approx. 0.5 kg

Fig. 3: Table of specifications

Technical specifications subject to change without notice

Observe copyright protection ISO 16016

2.4 Design and principle of operation

The electro-pneumatic positioner type baelz 87 can be fitted to a pneumatic actuator and is used to set the position of the valve (controlled variable x) according to the control signal (reference variable w). The positioner compares the electric control signal of a control system to the stroke of the valve and issues a pneumatic signal (output variable y).

The positioner consists of the following main components (see Fig. 4, page 10):

- Magneto-resistive sensor (2)
- Analogue I/P converter (6) with
- downstream air capacity booster (7)
- Electronics unit with microcontroller (4)

The travel or angle of rotation is measured by the outer pick-up lever (see Fig. 5, page 10), the non-contact magneto-resistive sensor and the downstream electronics.

The pick-up lever is connected to a magnet inside the device. The motion of the pick-up lever causes the direction of the magnetic field to change. This change is sensed by the sensor (2). Based on this information, the electronics unit connected downstream determines the current position of the actuator spindle.

The position of the actuator spindle is transmitted to the microcontroller (3) via the A/D converter (4). The PD control algorithm in the microcontroller (4) compares this actual position to the 4 to 20 mA control signal after it has been converted by the A/D converter.

In case of a control deviation (difference between setpoint X set (s) and actual position X(s)), the activation of the I/P converter (6) is changed so that the actuator of the valve (1) is either pressurized or vented via the downstream air capacity booster (7). The supply air is supplied to the pneumatic air capacity booster (7) and the pressure regulator (8).

The pneumatic signal supplied by the booster can be limited to 2.3 bar by software.

The volume restriction Q (10) is used for adaptation to the actuator.

2.4.1 Tight-closing function

The pneumatic actuator is completely vented or filled with air as soon as the reference variable falls below 1 % or exceeds 99 % (see table 8.1, page 34, end position parameters P10 and P11).

2.4.2 Direction of control action

Refer also to chapter 4.2.1 and chapter 6.4.

The default direction of control action of the positioner is ATO (air to open): pressure failure → valve **closed**.

The direction of control action can be changed to ATC (air to close): pressure failure → valve **open**

The pneumatic actuator has the following directions of control action: FO / SA (spring above) and FU / SB (spring below).

The valve has two optional closing directions: *spindle up = valve closed* and *spindle down = valve closed*.

The combinations resulting from these options are shown below.

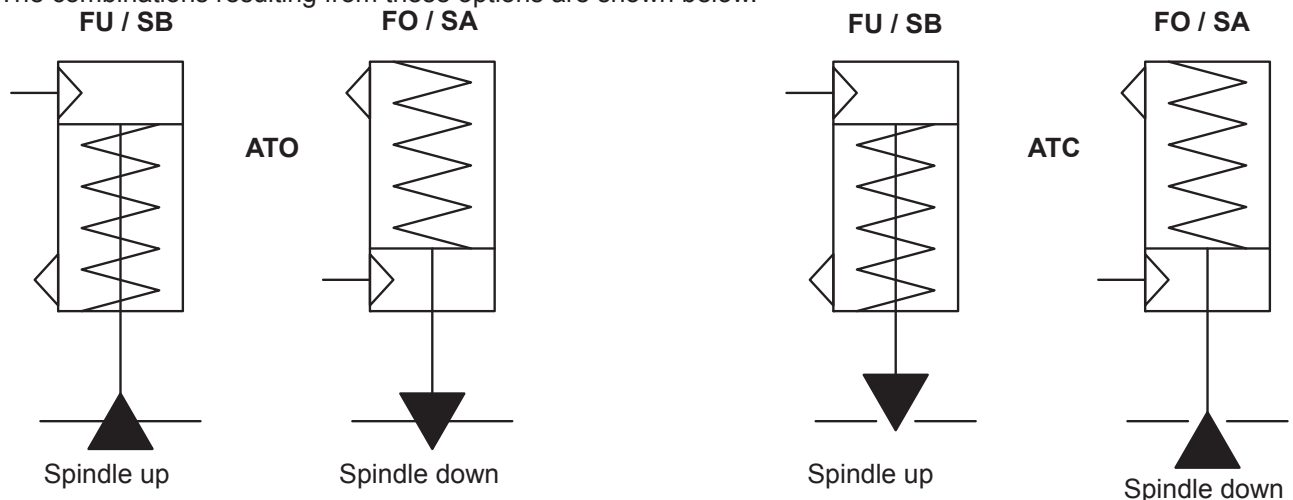

BA_87_02_EN_MJ_4017

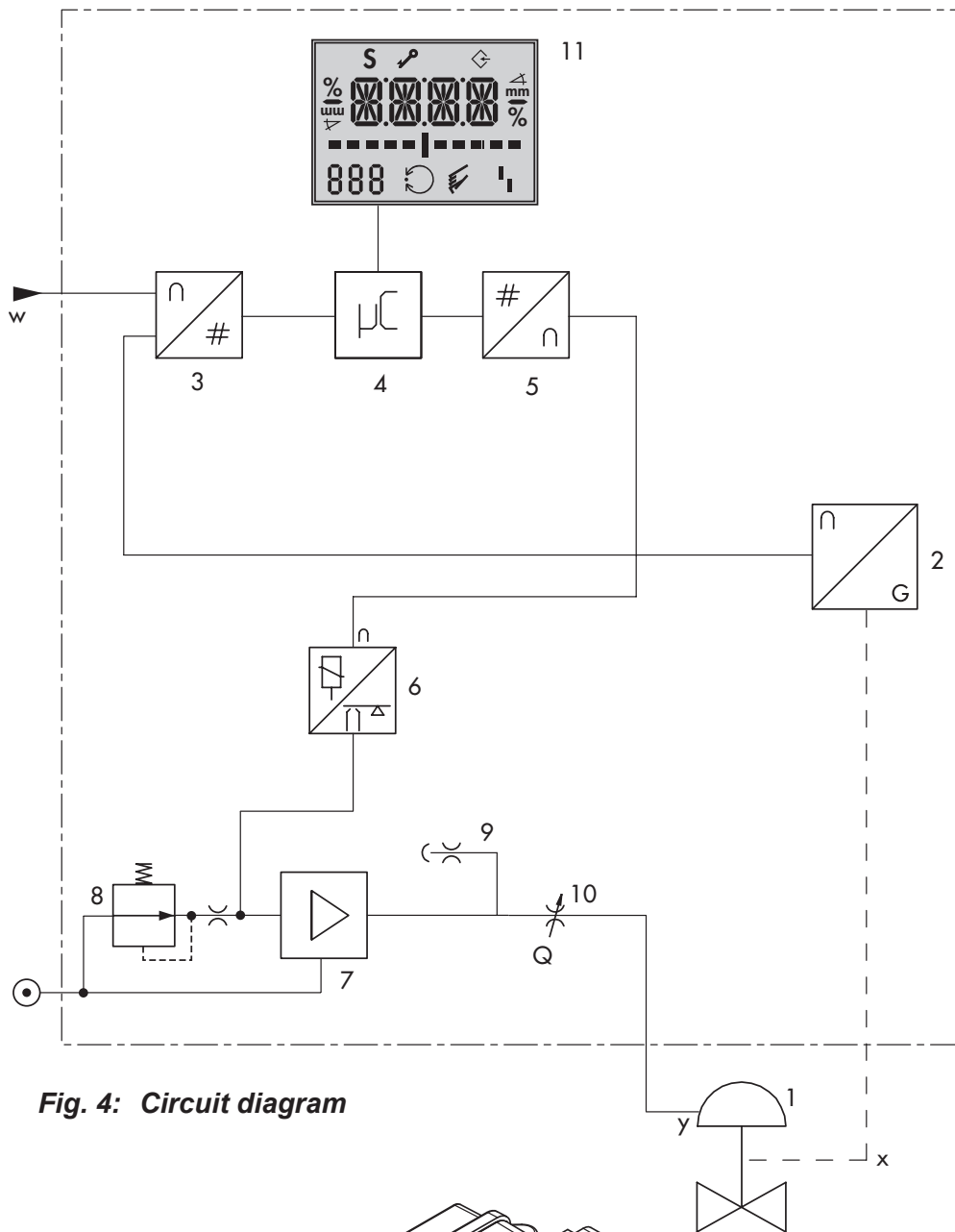

- 1 Valve
- 2 Sensor
- 3 A/D converter
- 4 Microcontroller
- 5 D/A converter
- 6 I/P converter
- 7 Air capacity booster
- 8 Pressure regulator
- 9 Fixed restriction
- 10 Volume restriction
- 11 Display

Fig. 4: Circuit diagram

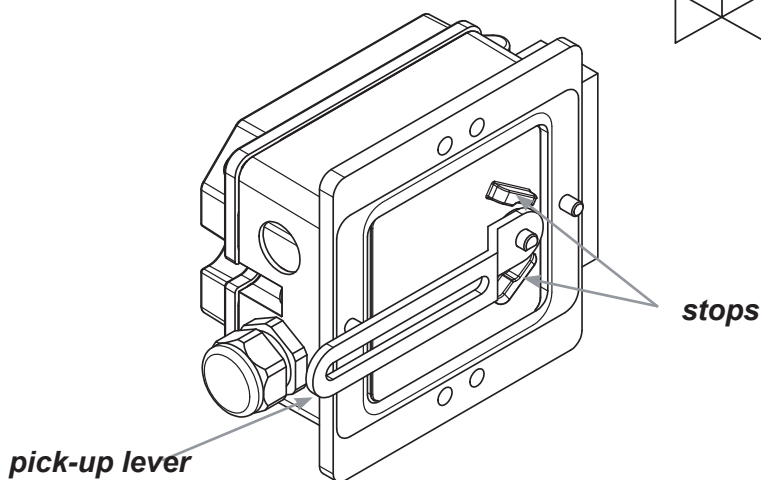

Fig. 5: Pick-up lever and mechanical stops

2.5 Accessories

- **Adaptation parts, complete**
for yoke S21, S21-L, S41 (configuration, see pages 13 ff.)
including pneumatic connecting parts
for replacement or retrofitting
Weight approx. 0.2 kg
Stroke max. 12...66 mm
- **Pneumatics connection kit**
pneumatic connecting parts
2 x plug connection, L-shaped
1 x plug connection, straight
1 x polyamide tube, 1 m
- **Manometer mounting kit**
incl. 2 manometers (configuration, see below)
Housing: Ø 40 mm
Connection: 1 / 4 NPT
Display range: 0...10 bar

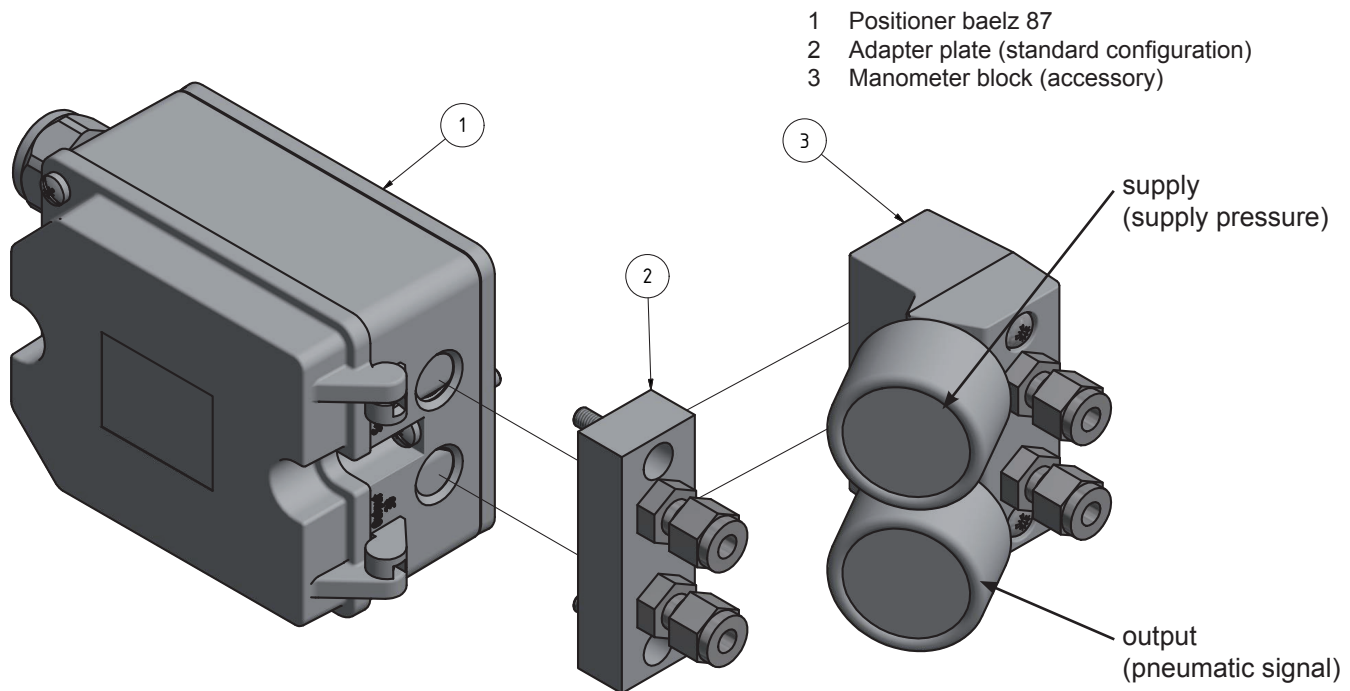

Fig. 6: Configuration with manometer block and optional accessories

2.6 Operating conditions



Positioners and related actuators are suitable for installation in industrial plants and in waterworks and power plants with a low pollutant concentration.

BA_87_02_EN_MJ_4017

For use outdoors or in an environment with a high pollutant concentration, such as areas with heavy traffic, industrial areas (chemical plants, sewage plants, etc.), coastal areas and the open sea, the actuators must have external parts made of non-corrosive material and must be provided with a special coating.

When used outdoors, the actuator must be protected with an additional cover against

- rain
- direct sunlight
- strong draughts
- dust

3. TRANSPORT AND STORAGE



Risk of injury caused by failure to observe the safety regulations!

Caution

- Wear the required personal and other protective equipment.
- Protect the positioner from impacts, shock, vibration and similar influences.
- Store the positioner (and, if necessary, the complete actuator/valve assembly) in a dry place.
- Observe the transport and storage temperature: -20°C to +80°C.
- Prevent condensation inside the housing.

4. MOUNTING



Attention

- **Do not mount the positioner with the vent opening facing upward!**
- **Do not seal the vent opening!**

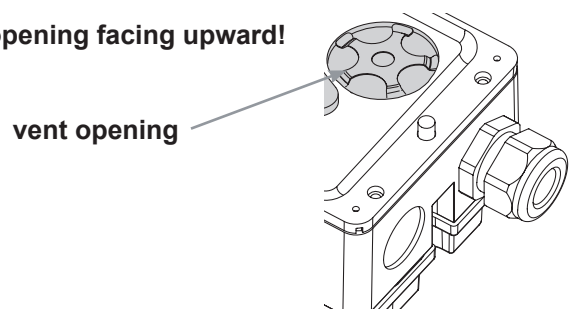

4.1 Positioner mounting

4.1.1 Mounting with yoke S21 / S21-L

See Fig. 7, page 13 and Fig. 8, page 14.

Cut 2x M6 thread for the M6x35 mm cylinder head screw (Pos. 3) into the existing Ø5 mm holes in the yoke.



Attention

Use the holes on the upper and lower **left** of the fixing plate (Pos. 1). Position the fixing plate so that the labelling "Hub 12/16/22/40" **appears above the upper left hole.**

4.1.2 Mounting with yoke S41

See Fig. 9, page 15.

Cut 2x M6 thread for the M6x35 mm cylinder head screw (Pos. 3) as shown in Fig. 10, page 16.



Attention

Use the holes on the upper and lower **right** of the fixing plate (Pos. 1). Position the fixing plate so that the labelling "Hub 44/66" **appears above the upper right hole.**

Parts list	Mounting with yoke S21	Pcs.
Pos. 1	Fixing plate	1
Pos. 2	Distance bushing Ø6,4xØ10x20mm	2
Pos. 3	Cylinder head screw M6x35mm	2
Pos. 4	Spring washer M6 DIN127	3
Pos. 5	Lever	1
Pos. 6	Nut M6	1
Pos. 7	Adapter plate	1
Pos. 8	O ring Ø14x2,5mm	2
Pos. 9	Self-tapping screw for plastic Ø5x20mm	2
Pos. 10	Actuating bolt	1
Pos. 11	Adapter	4
Pos. 12	Cheese head socket screw M6x30mm	4
Pos. 13	Cheese head socket screw M6x20mm	2
Pos. 14	Nut M6, flat, DIN 439	4
Pos. 15	Setscrew M6x25mm	4

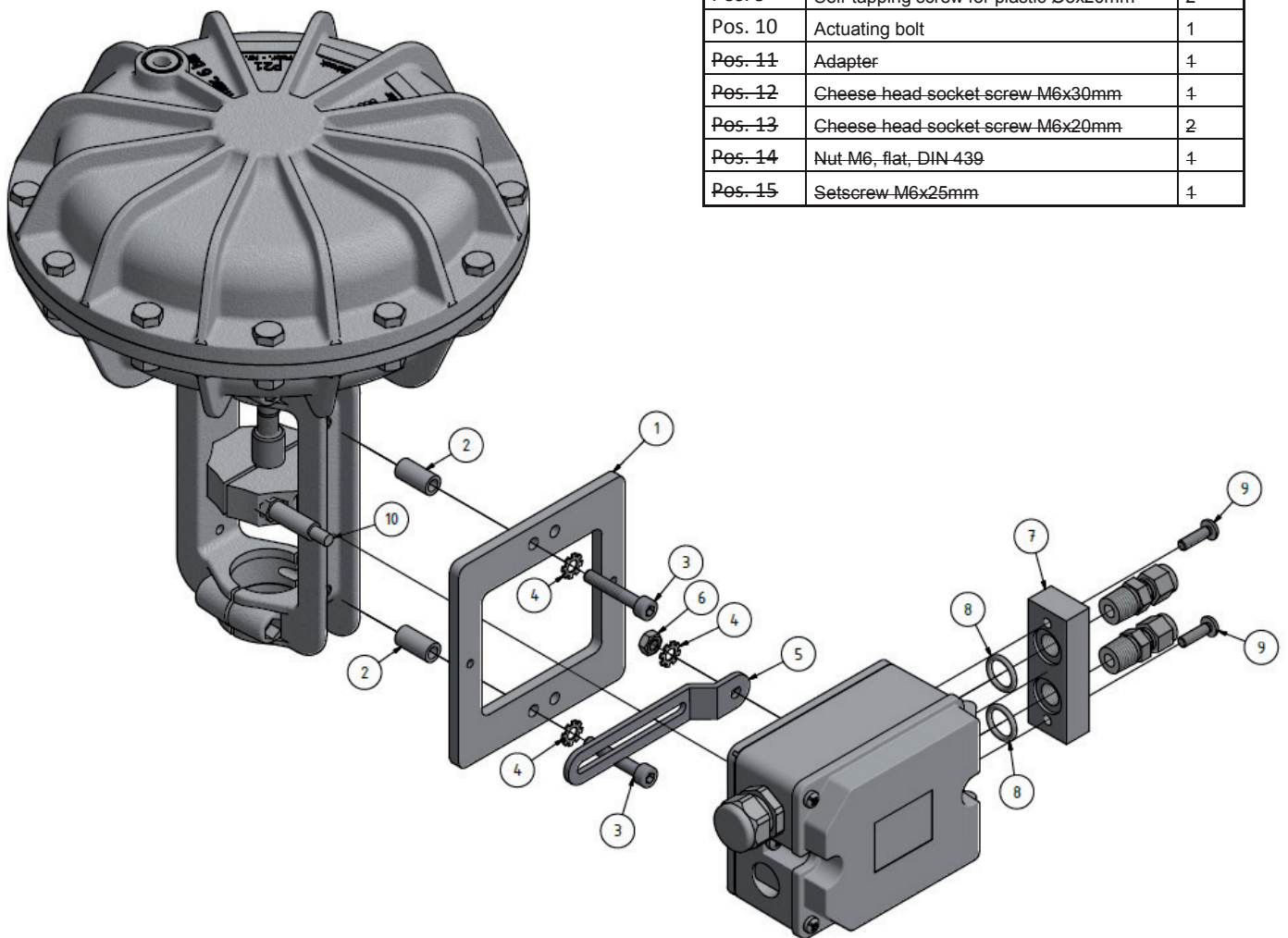

Fig. 7: Mounting with yoke S21

Parts list	Mounting with yoke S21-L	Pcs.
Pos. 1	Fixing plate	1
Pos. 2	Distance bushing Ø6,4xØ10x20mm	2
Pos. 3	Cylinder head screw M6x35mm	2
Pos. 4	Spring washer M6 DIN127	3
Pos. 5	Lever	1
Pos. 6	Nut M6	1
Pos. 7	Adapter plate	1
Pos. 8	O ring Ø14x2,5mm	2
Pos. 9	Self-tapping screw for plastic Ø5x20mm	2
Pos. 10	Actuating bolt	1
Pos. 11	Adapter	1
Pos. 12	Cheese head socket screw M6x30mm	1
Pos. 13	Cheese head socket screw M6x20mm	2
Pos. 14	Nut M6, flat, DIN 439	4
Pos. 15	Setscrew M6x25mm	4

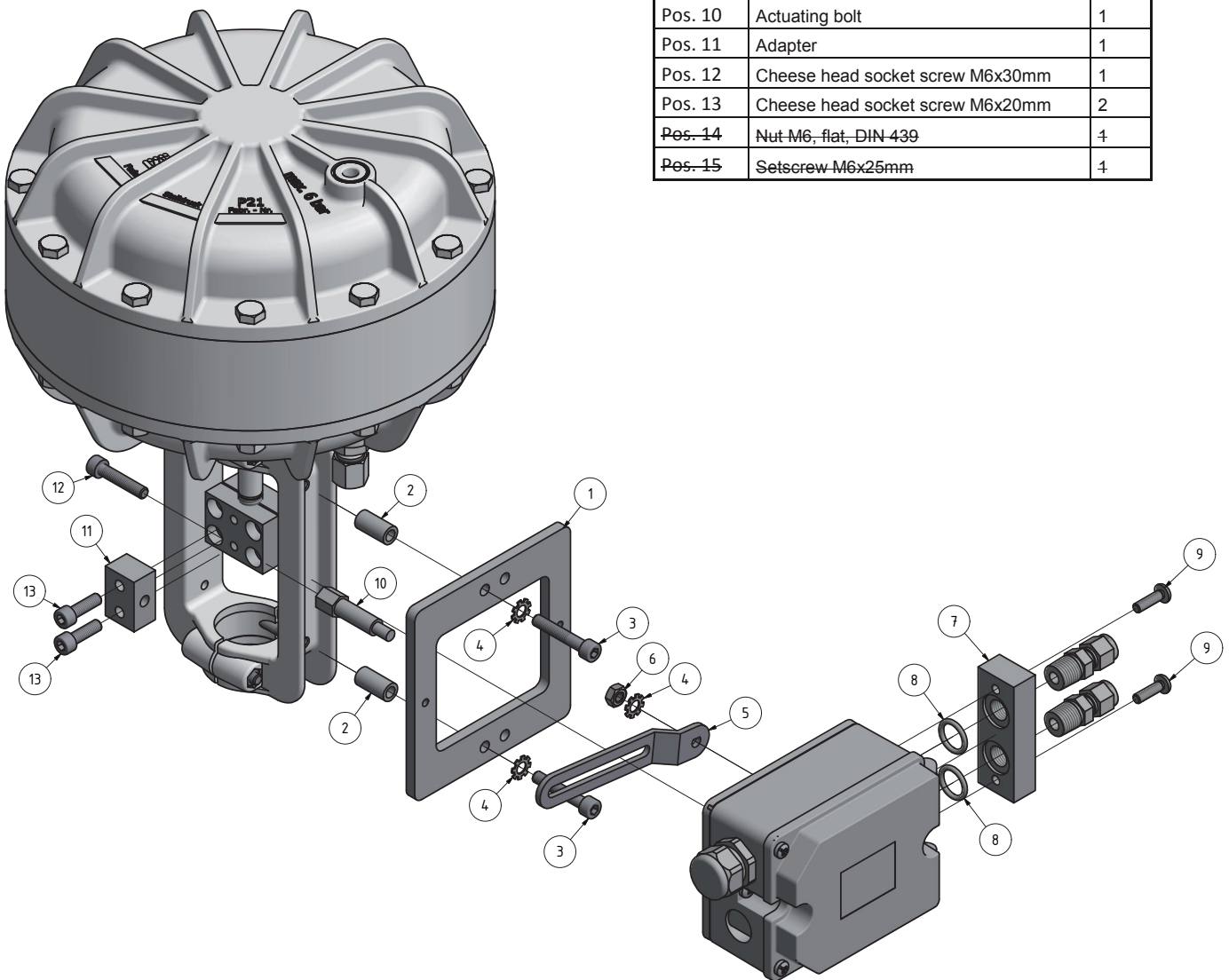

Fig. 8: Mounting with yoke S21-L

Parts list	Mounting with yoke S41	Pcs.
Pos. 1	Fixing plate	1
Pos. 2	Distance bushing Ø6,4xØ10x20mm	2
Pos. 3	Cylinder head screw M6x35mm	2
Pos. 4	Spring washer M6 DIN127	3
Pos. 5	Lever	1
Pos. 6	Nut M6	1
Pos. 7	Adapter plate	1
Pos. 8	O ring Ø14x2,5mm	2
Pos. 9	Self-tapping screw for plastic Ø5x20mm	2
Pos. 10	Actuating bolt	1
Pos. 11	Adapter	1
Pos. 12	Cheese head socket screw M6x30mm	1
Pos. 13	Cheese head socket screw M6x20mm	2
Pos. 14	Nut M6, flat, DIN 439	4
Pos. 15	Setscrew M6x25mm	4

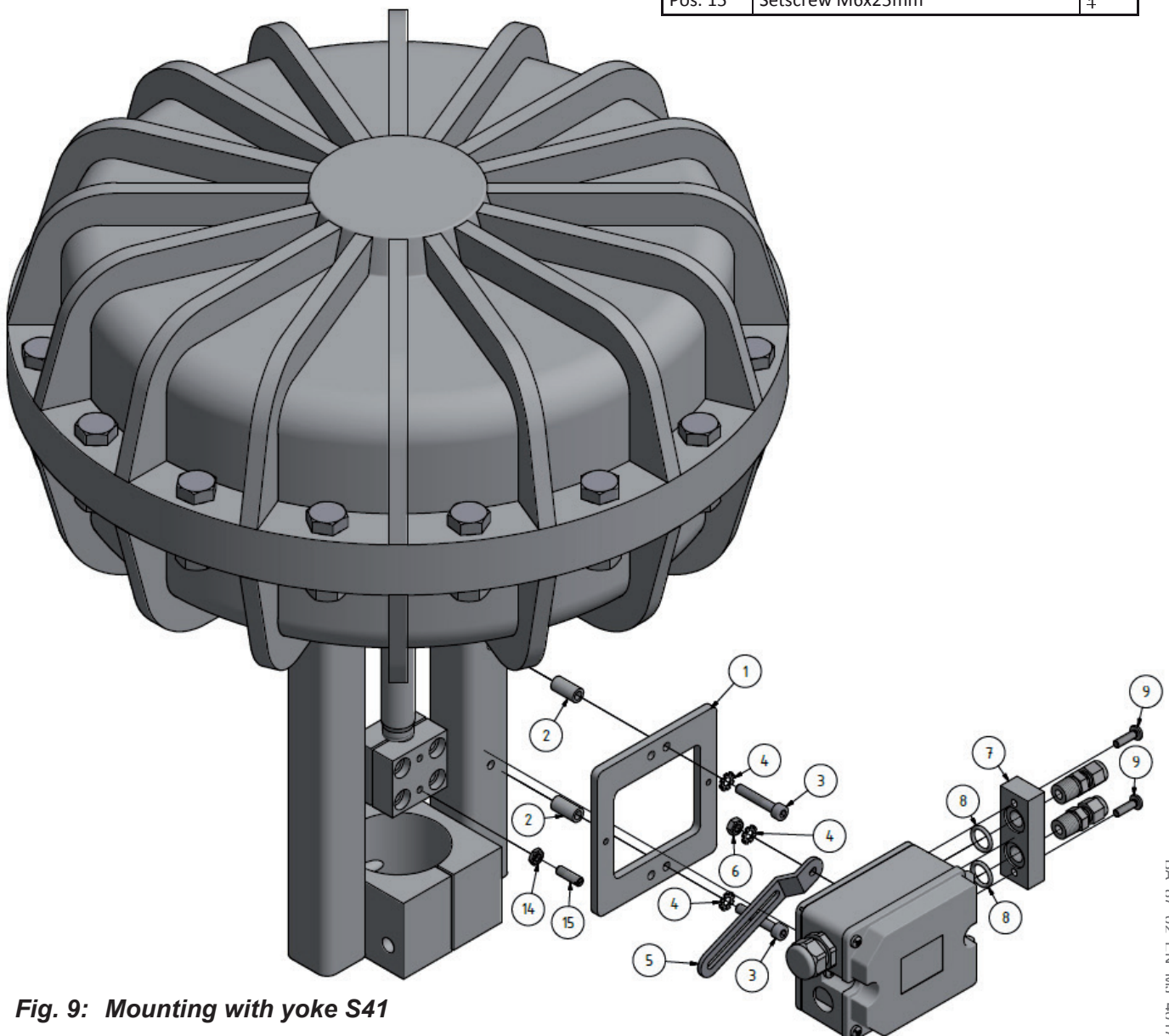

Fig. 9: Mounting with yoke S41

BA 87 02 EN M1 4017

Technical specifications subject to change without notice

Observe copyright protection ISO 16016

W. Bälz & Sohn GmbH & Co.
 Phone +49 (0)7131 15 00 0

Koepffstrasse 5
 Fax +49 (0)7131 15 00 21

74076 Heilbronn
 www.baelz.de

Germany
 mail@baelz.de

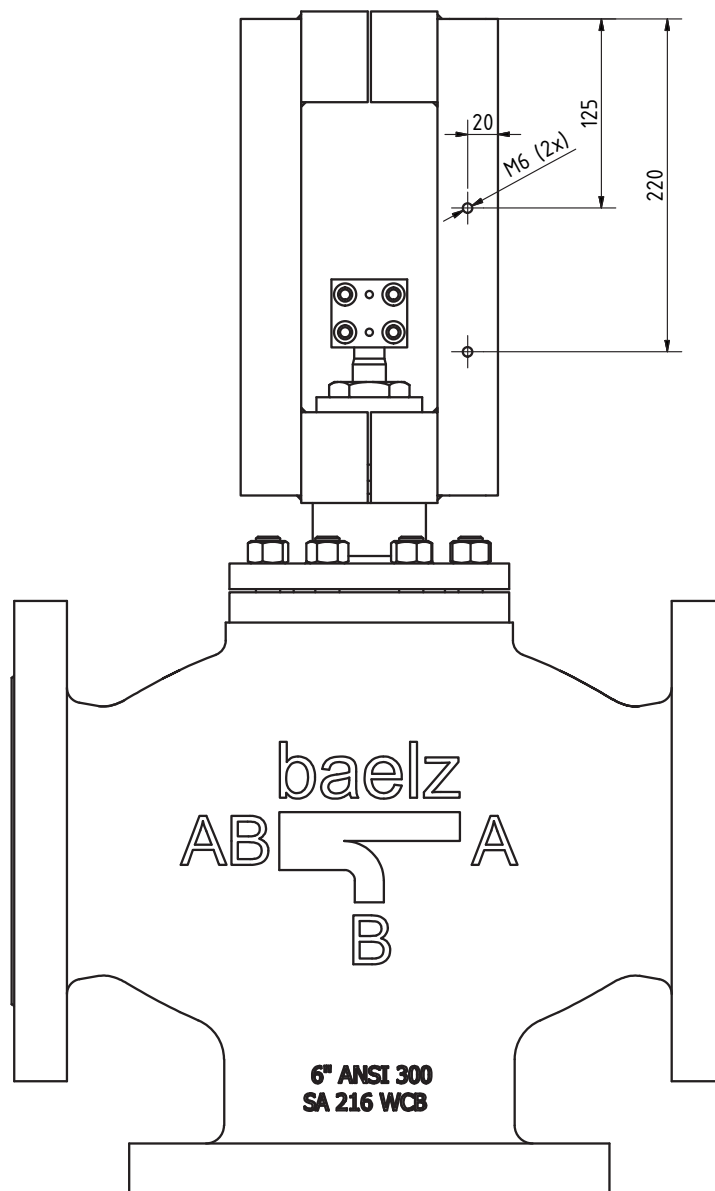

Fig. 10: Hole pattern for mounting onto yoke S41

4.2 Pneumatic connection



**Risk of injury by possible movement of the actuator spindle after connecting the air supply!
Do not touch or block the actuator spindle!**

Warning

The pneumatic connections are designed as a G ¼ threaded hole. Standard fittings for metal and copper pipes or plastic tubes can be used.

The following applies for pneumatic connections:

- Always screw connection fittings into the adapter plate or the manometer block, never directly into the positioner housing!
- Keep the length of the tube or line as short as possible to avoid delays in control signal transmission.



Attention

Contaminated supply air can lead to malfunctioning!
Always use supply air that is dry and free of oil and dust!
Read the maintenance instructions for upstream pressure reducing stations!
Thoroughly purge all air pipes and hoses with air before connecting them!



Tip:

Baelz recommends installing manometers (see Accessories, chapter 2.5, page 11) for supply air (supply) and pneumatic signal (output).

4.2.1 Supply pressure

The required supply pressure depends on the nominal signal range and the actuator's direction of control action (fail-safe action). Depending on the actuator type, the nominal signal range is shown on the name plate either as the spring range or pneumatic signal range. The direction of control action is indicated by lettering **FO / SA** (spring above) or **FU / SB** (spring below), or by a symbol.



Info:

Selection of the positioner's direction of control action also depends on the closing direction of the valve. See chapter 2.4.2.

Supply pressure for fail-safe action “Valve closed” (for 2-way valves and angle valves):

→ Required supply pressure = nominal signal range limit value + 0.2 bar, minimum 1.4 bar.

Supply pressure for fail-safe action “Valve open” (for 2-way valves and angle valves):

→ For tight-closing valves, the required supply pressure is determined on the basis of the maximum pneumatic signal p_{st_max} as follows:

$$p_{st_max} = F + \frac{d^2 \cdot \pi \cdot \Delta p}{4 \cdot A} \text{ [bar]}$$

- d = Seat diameter [cm]
- Δp = Differential pressure across the valve [bar]
- A = Actuator area [cm²]
- F = Nominal signal range limit value of the actuator [bar]

If no other specifications are made, calculate as follows:

Required supply pressure = nominal signal range limit value + 1 bar.



Info:

The pneumatic signal at the output (Output 38) of the positioner can be restricted to approx. 2.3 bar by setting parameter P9 to ON.

4.3 Electrical connection



Danger

Risk of electric shock and/or formation of explosive atmospheres!

For mounting and installation in hazardous areas, observe the relevant standards that apply in the country of use! Standard applicable in Germany: EN 60079-14, VDE 0165-1:

Explosive Atmospheres: Design, Selection and Erection of Electrical Installations.“

In hazardous areas, the device must be installed and serviced so as to ensure that any electrostatic charging of the plastic housing is prevented.



Attention

- Incorrect electrical connection will render the explosion protection ineffective!
- Adhere to the terminal assignment!
- Do not unscrew any screws in the housing which have been painted over!
- Do not exceed the maximum permissible values specified in the EC type examination certificates ($U_i = 28 \text{ V}$; $I_i = 115 \text{ mA}$; $P_i = 1 \text{ W}$; $C_i = 8.3 \text{ nF}$; L_i negligible) when interconnecting intrinsically safe electrical equipment!

4.3.1 Electric power supply

- Only use a current source and never a voltage source!
- Keep the reference variable within the destruction limit of $\pm 33 \text{ V}$!

4.3.2 Selecting cables and wires

- For the installation of the intrinsically safe circuits observe paragraph 12 of EN 60079-14, VDE 0165, Part 1!
- Paragraph 12.2.2.7 applies when wiring and connecting multi-core cables and wires with more than one intrinsically safe circuit.
- Radial thickness of the insulation of a wire for common insulating materials such as polyethylene: minimum 0.2 mm.
- Diameter of an individual wire in a fine-stranded conductor: minimum 0.1 mm.
- Strip 8 mm insulation off the wire ends.
- Protect the wire ends against splitting, e.g. by using wire-end ferrules.

4.3.3 Wiring

The M20 x 1.5 cable gland is designed for a clamping range of 6 to 12 mm.
The spring-type terminals hold wire cross-sections of 0.2 to 1.5 mm².

- To unlock the spring-type terminals, place a slotted screwdriver on the plastic component (Fig. 11, page 19) and lightly push it into the terminal block.
- Insert or remove the wire **without using force**.
- Connect the wire for the reference variable (mA control signal) as shown in Fig. 11, page 19.



Risk of malfunction due to incorrect order of mounting, installation, and commissioning!

Attention

Observe the following order of operations:

1. Remove the protective caps from the pneumatic connections.
2. Mount the positioner on the valve.
3. Connect the air supply.
4. Connect the electrical supply.
5. Perform the start-up settings.

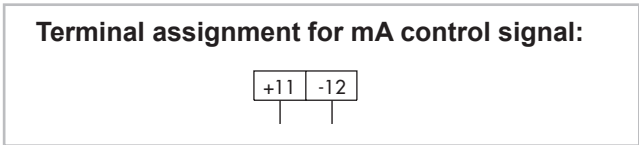
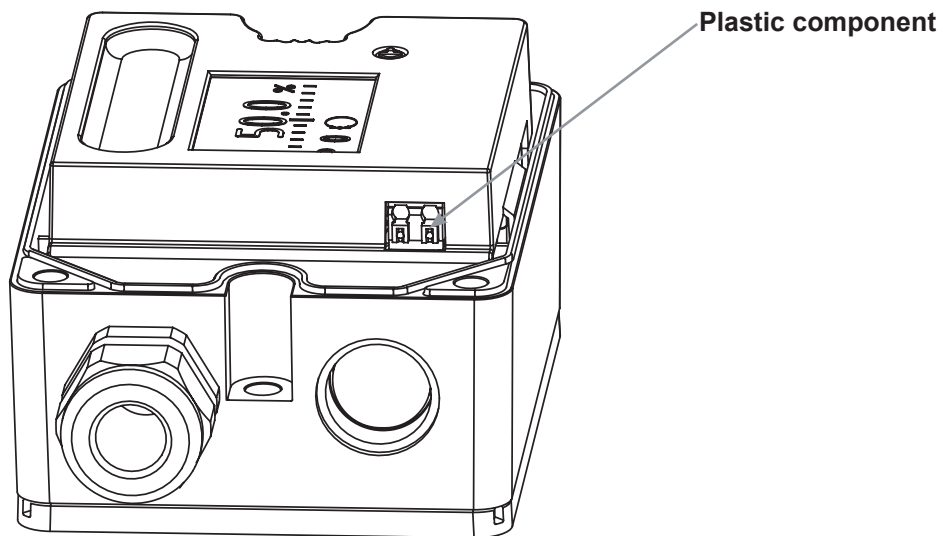

Fig. 11: Electrical connections

BA_87_02_EN_MJ_4017

5. OPERATION

5.1 Operating controls

Three capacitive keys are used to operate the positioner. These are touch-sensitive keys which allow the operator to navigate within the menus displayed (Fig. 12, page 21). Additionally, the volume restriction Q allows the air output capacity to be adapted to the size of the actuator.

5.1.1 Capacitive keys

△ key: "Up"

* key: "Confirm"

▽ key: "Down"

Touch the △ or ▽ key to select a parameter code (**P0** to **P20**). Then touch the * key to confirm the selected code.

To save changes to parameters in a non-volatile memory, proceed as follows:

- After changing parameters, touch the △ or ▽ key to change to Code **P0** or
- wait three minutes until the display returns automatically to **P0**.

i Info:

- The ⇄ icon on the display indicates that the changed parameter settings have not yet been saved in the non-volatile memory.
- The positioner remains active in a selected menu item, until this menu item is exited.
- After changing parameters **P2**, **P4** and **P8**, the positioner must be re-initialized.

5.1.2 Volume restriction Q

The volume restriction is used to adapt the air output capacity to the size of the actuator. Two fixed settings are available (see chapter 6.3).

5.1.3 Display

Icons which are assigned to certain codes and functions are shown on the display (Fig. 12). The bar graph shows the control deviation with sign and value. One bar element appears per 1% control deviation. If the positioner has not yet been initialized, the lever position in degrees in relation to the mid-axis will be shown. One bar graph element corresponds to an angle of rotation of approximately 7°. If the fault icon  is displayed, touch the Δ or ∇ key until **ERR** is displayed to view the error codes **E0** to **E15** (see chapter 7.2).

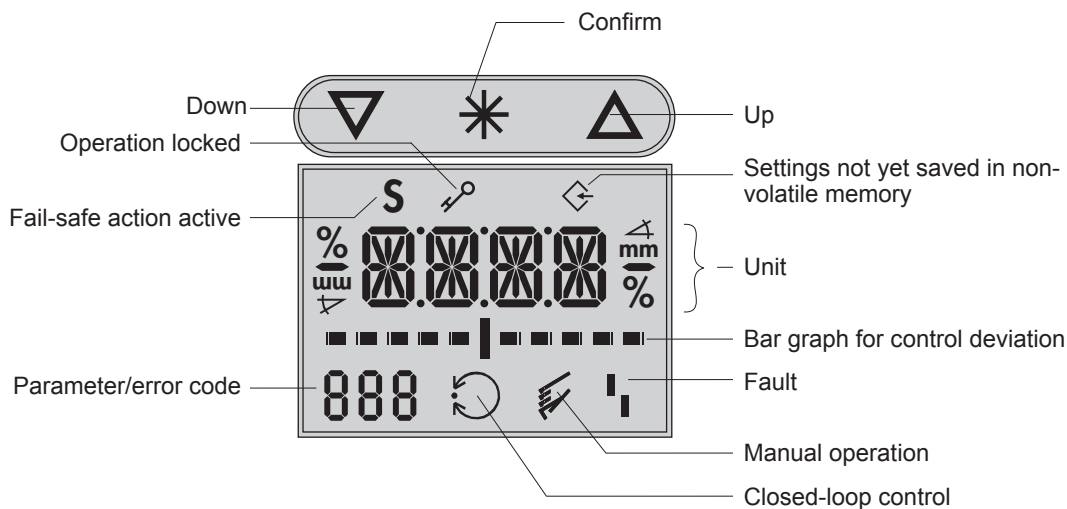

Text displayed	Meaning
ESC	Stop
Err	Fault
LOW	w too low
MAN	Manual operation
MAX	Maximum range
RST	Reset
INIT	Initialisation
ON/OFF	Settings
ZERO	Zero calibration

Fig. 12: Display showing all display elements

6. OPERATING THE POSITIONER

Before start-up, mount the positioner following the order described in chapter 4. Apply the electric reference variable to start up the positioner, see chapter 4.3.

i Info

- **LOW** on the positioner's display indicates that the reference variable is lower than 3.8 mA.
- For most applications, the positioner is ready for operation with its default settings (factory setting).
- After connecting the electrical supply, the positioner performs a calibration of the capacitive keys which takes approx. three seconds. Do not touch the keys during this time. Touching the keys during calibration prevents them from functioning correctly. A reset can only be performed by disconnecting the power supply.

Display after connecting the power supply

Display when the positioner has **not** yet been initialized:

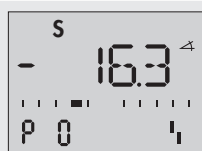

Code **P0** is displayed. The fault icon **I** and **S** for fail-safe action are displayed. The reading indicates the lever position in degrees in relation to the mid-axis.

Display when the positioner has been initialized:



Code **P0** is displayed. The positioner is in closed-loop operation indicated by the closed-loop operation icon . The indicated value corresponds to the control position in %.
For details on initialisation of the positioner, refer to chapter 6.8.

6.1 Adapting the display

The data displayed on the screen can be rotated by 180°. If the displayed data appear upside down, proceed as follows:



1. Touch Δ or ∇ until code **P1** is displayed.
2. Use \ast to confirm the selected code. **P1** flashes.
3. Touch Δ or ∇ until the display is set to the desired position.
4. Touch \ast to confirm screen direction.

6.2 Enabling configuration to change parameters

Before changing parameter settings in an initialized positioner, configuration must first be enabled by selecting code **P19**:



LOCK and the key icon indicate that the configuration is locked. Deactivate the lock function as follows:

1. Touch Δ or ∇ until code **P19** is displayed.
2. Use \ast to confirm the selected code. **P19** flashes.
3. Touch Δ or ∇ until **OPEN** is displayed.
4. Press \ast to enable configuration.

i Info

If no settings are entered within three minutes, the enabled configuration function will be reset to locked.

6.3 Adjusting the volume restriction Q

The volume restriction **Q** (Fig. 13) is used to adjust the air output capacity to the size of the actuator:
 Actuators with a **run time < 1 s**, e.g. linear actuators with an actuator area < 240 cm², require a restricted volume flow.

→ Set to **MIN**.

Actuators with a **run time ≥ 1 s** do not require a restriction of the volume flow.

→ Set to **MAX**.

Additional points concerning the volume restriction:

→ Intermediate positions are not permitted.

→ Re-initialize the positioner after changing the volume restriction setting.



Fig. 13: Adjusting the volume restriction Q (MAX/MIN setting)

6.4 Entering the direction of control action

See page 9 for graphical illustration.

- **ATO** (Air to open) applies, if an increasing pneumatic signal opens the valve → in case of pressure failure: valve **closed**.
Actuator with FU / SB (spring below) + spindle up → valve closed
Actuator with FO / SA (spring above) + spindle down → valve closed
- **ATC** (Air to close) applies, if an increasing pneumatic signal closes the valve → in case of pressure failure: valve **open**.
Actuator with FU / SB + spindle up → valve open
Actuator with FO / SA + spindle down → valve open

The pneumatic signal is the pneumatic pressure at the output of the positioner applied to the actuator.

ATO

P 2 ↻

*Default direction of control action: **ATO**.*

To change the direction of control action (enable configuration as described in chapter 1.2):

1. Touch **Δ** or **∇** until code **P2** is displayed.
2. Use ***** to confirm the selected code. **P2** flashes.
3. Touch **Δ** or **∇** until the desired direction of control action is displayed.
4. Confirm the setting with *****.

i Info

The changed direction of control action will only become effective after the positioner has been re-initialised.

6.5 Entering the direction of motion

The direction of motion P7 is set to increasing/increasing (>>) by default, i.e. when the positioner is initialised, 0% is displayed when the valve is fully closed and 100% when the valve is fully open. If necessary, the direction of motion can be changed (enable configuration as described in chapter 6.2):

{>>}

P 7 ↻

Changing the direction of motion to increasing/ decreasing:

1. Touch **Δ** or **∇** until code **P7** is displayed.
2. Use ***** to confirm the selected code. **P7** flashes.
3. Touch **Δ** or **∇** until **<>** is displayed.
4. Confirm the setting with *****.

The following correlation applies:

Valve	CLOSED	OPEN
Display	0%	100%
Direction of motion increasing/increasing (>>)	4 mA	20 mA
Direction of motion increasing/decreasing (<>)	20 mA	4 mA

6.6 Limiting the pneumatic signal

If the maximum actuator force is too high for the valve used, the limit for the pneumatic signal can be activated using code **P9**. The pressure will then be restricted to approx. 2.3 bar.

ON

P 9

To activate the limitation of the pneumatic signal (enable configuration as described in chapter 6.2):

1. Touch Δ or ∇ until code **P9** is displayed.
2. Use \ast to confirm the selected code. **P9** flashes.
3. Touch Δ or ∇ until **ON** is displayed.
4. Confirm the setting with \ast .

6.7 Setting other parameters

The following table lists all parameter codes and their factory default settings. To change parameters, proceed as described in the previous chapter.

For more details concerning the parameter codes, refer to the code list (see chapter 8).

Parameter codes [factory settings]			
P0	Status display	P11	End position w > [OFF]
P1	Screen direction	P12	Limit A1, min. [2%]
P2 ¹⁾	ATO/ATC [ATO]	P13	Limit A2, max. [98%]
P3 ¹⁾	Pin position [35]	P14	Display of reference variable w
P4 ¹⁾	Nominal range [MAX]	P15	INIT Start initialisation
P5	Characteristic [0]	P16	ZERO Start zero calibration
P6	Reference variable [4 to 20 mA]	P17	MAN Manual operation
P7	w/x direction of motion [>>]	P18	RST Reset
P8 ¹⁾	Gain Kp [50]	P19	Enable configuration
P9	Pressure limitation 2.3 bar [OFF]	P20	Info Firmware version
P10	End position w < [ON]		

¹⁾ Positioner needs to be re-initialised after changing the parameter settings

6.8 Initialisation

A self-adjustment during initialisation ensures that the positioner is perfectly adjusted to the friction conditions and the pneumatic signal required by the valve.



Risk of injury due to extending or retracting actuator spindle!
Do not touch or block the actuator spindle!



Process disruption due to unregulated movement of the actuator spindle!
Do not initialise the positioner while a process is in progress!
Close shut-off devices before initialisation!

The type and extent of self-adjustment depends on the preset parameters. **MAX** is the default setting for the nominal range (code **P4**). During the initialisation process, the positioner determines the total travel range or rotational range of the valve (from valve position "CLOSED" to the opposite end position).

Starting initialisation (enable configuration as described in chapter 6.2):

1. Touch Δ or ∇ until code **P15** is displayed.
2. Touch and hold * for six seconds (display **6...5...4...3...2...1**).

The initialisation starts and **INIT** flashes. The time required for the initialisation depends on the actuator run time and can take a few minutes.

Initialisation successfully completed. The positioner is in closed-loop operation indicated by the closed-loop operation icon \curvearrowright .

The indicated value corresponds to the control position in %.

Configuration is locked, indicated by the key icon.

If initialisation fails, the fault icon \blacksquare will be displayed.

6.8.1 Stopping initialisation

The initialisation can be stopped:

1. While initialisation is in progress, touch the * key: **ESC** is displayed flashing.
2. Confirm with the * key: The initialisation stops.

i Info

*This code must be confirmed by touching the * key. Otherwise the positioner will remain in this menu.*

Initial state 1:

*The positioner is **not** initialised.*

When initialisation is stopped, the positioner moves to the fail-safe position.

Initial state 2:

The positioner is initialised.

When stopping a new initialisation, the positioner returns to closed-loop operation. In this case the settings of the previous initialisation will be used.

A new initialisation can be started directly afterwards.

6.9 Zero calibration

In case of inconsistencies in the closing position of the valve, e.g. with soft-seated plugs, it might be necessary to recalibrate the zero point using code **P16** (enable configuration as described in chapter 6.2).

Start the zero calibration by activating code **P16** as follows:

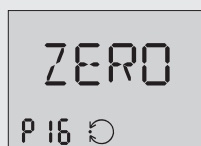

1. Touch Δ or ∇ until code **P16** is displayed.

2. Touch and hold * for six seconds (display **6...5...4...3...2...1**).

*The zero calibration starts and **ZERO / INIT** flashes.*

The time required for the initialisation depends on the actuator run time and can take a few minutes.

The positioner moves the valve to the CLOSED position and recalibrates the internal electric zero point. When the zero calibration has been successfully completed, the positioner returns to closed loop operation.

6.9.1 Stopping zero calibration

The zero calibration can be stopped:

1. While zero calibration is in progress, touch the * key: **ESC** flashes.
2. Confirm with the * key: The zero calibration is stopped.

i Info:

*This code must be confirmed by touching the * key. Otherwise the positioner will remain in this menu. The positioner then changes to closed-loop operation without performing a zero calibration. A new zero calibration can be started directly afterwards.*

6.10 Manual operation

The valve position can be moved as follows using the **manual operation** function:

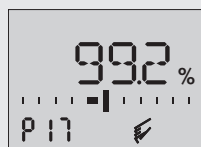

Enable configuration, see chapter 1.2.

1. Touch Δ or ∇ until code **P17** is displayed.
2. Touch and hold * for six seconds (display **6...5...4...3...2...1**), **P17** flashes.

If the positioner is initialised, the current valve position will be displayed.

If the positioner is not initialised, the lever position in degrees in relation to the mid-axis will be displayed.

3. Touch Δ or ∇ to change the manual operation setpoint.

Positioner initialised

Manual operation starts with the last setpoint used in closed-loop operation to ensure an impact-free changeover. The bar graph on the display indicates the control deviation between the manual operation setpoint and the setpoint used for closed-loop control while the valve is moved using **P17**.

The manual operation setpoint is adjusted in steps of 0.1%. The position is controlled.

Positioner not initialised

△ or ▽ must be touched for some time to move the valve manually.

The position is not controlled. The bar graph on the display indicates the change in direction.

Touch the * key to deactivate manual operation.

i Info

The manual operation function can only be terminated as described or by interrupting the power supply (cold start). The positioner does **not** automatically exit this function and return to the status display.

6.11 Reset

A reset causes an initialisation to be undone and all parameters settings are reset to the factory default values (see codes list, chapter 8).

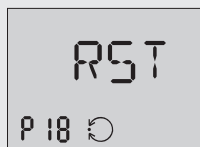

Enable configuration, see chapter 6.2.

1. Touch △ or ▽, until code **P18** is displayed.
2. Touch and hold * for six seconds (display 6...5...4...3...2...1).

RST flashes for as long as the * key is held. As soon as the key is released, the reset process is completed and the positioner returns to status display **P0**.

i Info

After a reset, the fault icon  is displayed since the positioner needs to be re-initialised. The error code **E2** is also activated (see chapter 7).

7. MALFUNCTIONS

In case of a malfunction, the fault icon  is displayed. By switching past code **P0** or **P20**, the respective error codes **E0** to **E15** together with **ERR** are displayed. Refer to the error codes list in chapter 7.4 for the cause of the errors and the recommended action.

Example:

If, for instance, a stroke has been entered in code **P4** (nominal range) which exceeds the maximum valve stroke, the initialisation process will be interrupted (error code **E2**) as the nominal stroke was not reached (error code **E6**). The valve moves to the fail-safe position (**S** indicated on the display).

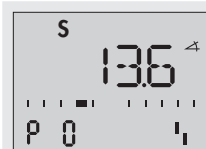

*Indication of the malfunction on the display:
The fault icon  is displayed.
The valve is in the fail-safe position (S indicated on the display).*

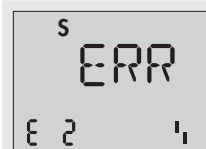

*Error code **E2**: Initialisation stopped.*

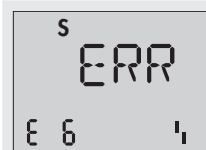

*Error code **E6**: Nominal stroke not reached.*

The nominal range (code **P4**) must be changed and the positioner re-started to remedy this problem.

7.1 Resetting error codes

Error codes **E0** and **E8** can be reset as follows:

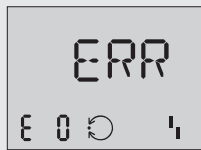

1. Touch **Δ** or **∇** to select the error code.

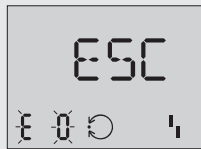

2. Touch ***** to confirm the error code. **ESC** is displayed, the error code flashes.

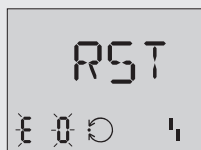

3. Touch **Δ** or **∇**, **RST** is displayed.

4. Confirm with ***** to reset the error.

The reset procedure can be stopped by touching the ***** key when **ESC** appears.

7.2 Error codes

The errors listed in the following table (chapter 7.4) are assigned to error classes:

- **Error class 1:** No operation possible
- **Error class 2:** Manual operation only
- **Error class 3:** Manual operation and closed-loop control possible

Contact Baelz for malfunctions not listed in the table (see footer).

7.3 Emergency action

In the event of a failure of the air supply and/or electrical supply, the positioner vents the actuator, causing the control valve to move to the fail-safe position determined by the actuator.

The plant operator is responsible for emergency action to be taken on site.

 **Tip:** *Emergency action in the event of a valve failure is described in the relevant valve documentation.*

7.4 Error codes

Code	Description		Class
E0	Zero error (operational error)	Only with tight-closing function P10 end position w < set to ON. The zero point has shifted by more than 5% compared to initialisation. This error may occur when the valve seat module is worn.	3
	Recommended action	Check valve and positioner for correct mounting. When the positioner is mounted correctly, perform a zero calibration using code P16 (see table 8.1, pages 34 ff). The error code can be reset (see chapter 7.1).	
E1	Displayed and INIT values are not identical (operational error)	Set and displayed values are not identical to the INIT values as parameters were changed after initialisation.	3
	Recommended action	Reset parameters or start new initialisation.	
E2	Positioner not initialized	Malfunction or parameter change requiring the positioner to be re-initialised.	2
	Recommended action	Set parameters and initialise the positioner using code P15 .	
E3	K_p setting (initialisation error)	Positioner hunts. Volume restriction set incorrectly, too much gain.	2
	Recommended action	Check the volume restriction setting as described in chapter 6.3. Limit gain K _p in code P8 . Re-initialise the positioner.	
E4	Run time too short (initialisation error)	The run times of the actuator determined during initialisation are < 0.5 s so that an optimum positioner adjustment is impossible.	2
	Recommended action	Check the volume restriction setting as described in chapter 6.3. Re-initialise the positioner.	
E5	Standstill cannot be detected (initialisation error)	Supply pressure varies. Incorrect mounting.	2
	Recommended action	Check supply air and correct positioner mounting. Re-initialise the positioner.	
E6	Failure to achieve the defined stroke during initialisation (initialisation error)	Supply pressure is too low, actuator leaks or pressure limit function activated. When MAX is selected for code P4 (nominal range): the measuring span of the lever is too small. Initialisation is stopped if the angle of rotation of the positioner shaft is less than 11°.	2
	Recommended action	Check supply air, positioner mounting, lever and setting. Re-initialise the positioner.	
E7	Actuator does not move (initialisation error)	No supply air, blocked due to incorrect mounting.	2
	Recommended action	Check supply air, positioner mounting and mA input signal. Re-initialise the positioner.	
E8	Stroke signal at lower/upper limit	Wrong pin position, wrong lever, wrong mounting direction when NAMUR attachment is used.	1
	Recommended action	Reset the error code (see chapter 7.1). Check positioner for correct mounting and re-initialise the positioner.	
E9 to E15	Device error (internal)	Return positioner to Baelz for repair.	1/3

BA_87_02_EN_MJ_4017

8. CODE LIST

8.1 Parameter code table

Code	Display, values [factory setting]	Description
Note: Codes marked by an asterisk * indicate that the positioner needs to be re-initialised		
P0	Status display with basic information	If the positioner is initialised, the reading indicates the valve position or angle of rotation in %. When touching the * key if the positioner is not initialised, the position of the lever in relation to the mid-axis is displayed.
P1	Screen direction	The reading direction of the display is rotated by 180°.
P2*	ATO/ATC [ATO]	Parameter to adapt the positioner to the valve's function: ATO: Air to open (pneumatic signal opens, fail-safe position CLOSED) ATC: Air to close (pneumatic signal closes, fail-safe position OPEN). See also chapter 2.4.2 Direction of control action
P3*	Pin position 17/25/[35]/50/90°	Do not change.
P4*	Nominal range [MAX]	MAX: maximum possible stroke
P5	Characteristic 0 to 2 [0]	Select characteristic: 0 linear 1 equal-percentage 2 reverse equal percentage
P6	Reference variable [4 to 20 mA] SRLO/SRHI	For split-range operation: SRLO: low range 4 to 11.9 mA SRHI: high range 12.1 to 20 mA
P7	w/x [>>]/<>	Direction of motion of valve position x to reference variable w (increasing/increasing or increasing/decreasing).
P8*	Gain K_p 30/[50]	On initialising the positioner, the gain is set to the selected value. The K _p value can be reduced to prevent hunting.
P9	Pressure limitation ON/[OFF]	The pneumatic signal must not exceed the pressure of the applied supply air [OFF] or, in case the maximum actuator force can damage the valve, can be restricted to approx.2.3 bar.
P10	End position w < [ON]/OFF	Lower tight-closing function: If w approaches up to 1% to the final value that causes the valve to close, the actuator is immediately completely vented (with ATO: air to open) or filled with air (with ATC: air to close).
P11	End position w > [ON]/OFF	Upper tight-closing function: If w approaches up to 99% to the final value that causes the valve to open, the actuator is immediately completely filled with air (in case of ATO: air to open) or vented (in case of ATC: air to close).

Operating Instructions

OI 87

P14	Info w Initialised	Indicates the internally adjusted setpoint in the positioner (adjusted setpoint in 0 to 100% according to P6 and P7). Touch the * key to display the external setpoint (applied setpoint in 0 to 100% according to the 4–20 mA signal).
	Not initialised	Indicates the external setpoint in 0 to 100 % according to the 4–20 mA signal.
P15	Start initialisation	The initialisation can be stopped by touching the * key. The valve will then move to the fail-safe position. After a power supply failure during initialisation, the positioner starts with the values of the last initialisation (if available).
P16	Start zero calibration	Zero calibration can be stopped by touching the * key. The valve will then return to closed-loop operation. Note: A zero calibration cannot be started as long as error code E1 persists. After a power supply failure during zero calibration, the positioner starts with the zero point values of the last zero calibration.
P17	Manual operation	Touch Δ or ∇ to enter the setpoint
P18	Reset	The parameters are reset to their default settings. The positioner can only return to closed-loop operation after it has been re-initialised.
P19	Enable configuration [LOCK]/OPEN	Enables configuration to change parameters. The enable configuration function is automatically cancelled when none of the keys are touched within three minutes.
P20	Info firmware version	The firmware version installed is displayed. Touching the * key displays the last four digits of the serial number.

8.2 Label on the inside of the cover

The label affixed to the inside of the cover shows parameter codes, error codes and commissioning instructions.

<table border="0"> <tr><td>Code</td><td>Parameter</td><td>Default</td></tr> <tr><td>P0</td><td>Status indication/reset</td><td>INIT</td></tr> <tr><td>P1*</td><td>Reading direction</td><td></td></tr> <tr><td>P2</td><td>ATO/ATC</td><td>ATO</td></tr> <tr><td>P3</td><td>Pin position</td><td>35 mm</td></tr> <tr><td>P4</td><td>Nominal range</td><td>Max.</td></tr> <tr><td>P5*</td><td>Characteristic</td><td>0</td></tr> <tr><td>P6*</td><td>Reference variable</td><td>4 to 20 mA</td></tr> <tr><td>P7*</td><td>w/x >>/<<</td><td>>></td></tr> <tr><td>P8</td><td>Gain K_p</td><td>50</td></tr> <tr><td>P9*</td><td>Pressure limit</td><td>OFF</td></tr> </table>	Code	Parameter	Default	P0	Status indication/reset	INIT	P1*	Reading direction		P2	ATO/ATC	ATO	P3	Pin position	35 mm	P4	Nominal range	Max.	P5*	Characteristic	0	P6*	Reference variable	4 to 20 mA	P7*	w/x >>/<<	>>	P8	Gain K_p	50	P9*	Pressure limit	OFF	<table border="0"> <tr><td>Code P5</td><td>0 Linear</td></tr> <tr><td></td><td>1 Equal percentage</td></tr> </table>	Code P5	0 Linear		1 Equal percentage	<p>Mounting/start-up instructions for Baelz 87</p> <p>2. Adapt positioner to valve: Press ∇/Δ arrow keys to select parameter and * key to activate the parameter if you want to change its default setting.</p> <p>3. In Code 15 "Start INIT", hold * button pressed until INIT starts automatically. Current value appears on the LCD after INIT has been completed successfully.</p>																		
Code	Parameter	Default																																																							
P0	Status indication/reset	INIT																																																							
P1*	Reading direction																																																								
P2	ATO/ATC	ATO																																																							
P3	Pin position	35 mm																																																							
P4	Nominal range	Max.																																																							
P5*	Characteristic	0																																																							
P6*	Reference variable	4 to 20 mA																																																							
P7*	w/x >>/<<	>>																																																							
P8	Gain K_p	50																																																							
P9*	Pressure limit	OFF																																																							
Code P5	0 Linear																																																								
	1 Equal percentage																																																								
<table border="0"> <tr><td>P10*</td><td>End position w <</td><td>ON</td></tr> <tr><td>P11*</td><td>End position w ></td><td>OFF</td></tr> <tr><td>P12*</td><td>Switching point A1</td><td>2 %</td></tr> <tr><td>P13*</td><td>Switching point A2</td><td>98 %</td></tr> <tr><td>P14</td><td>Info w/manual w</td><td></td></tr> <tr><td>P15</td><td>Start INIT</td><td></td></tr> <tr><td>P16*</td><td>Calibrate zero point</td><td></td></tr> <tr><td>P17</td><td>MAN Manual mode</td><td></td></tr> <tr><td>P18</td><td>RST Reset</td><td></td></tr> <tr><td>P19</td><td>LOCK Enable configuration</td><td></td></tr> <tr><td>P20</td><td>Firmware version</td><td></td></tr> </table>	P10*	End position w <	ON	P11*	End position w >	OFF	P12*	Switching point A1	2 %	P13*	Switching point A2	98 %	P14	Info w/manual w		P15	Start INIT		P16*	Calibrate zero point		P17	MAN Manual mode		P18	RST Reset		P19	LOCK Enable configuration		P20	Firmware version		<p style="font-size: small;">Code no. marked with * can be changed without new INIT.</p> <table border="1" style="width: 100%; border-collapse: collapse;"> <thead> <tr><th colspan="2">Error description:</th></tr> </thead> <tbody> <tr><td>E0</td><td>Zero point error</td></tr> <tr><td>E1</td><td>Reading and INIT values are not identical</td></tr> <tr><td>E2</td><td>Positioner not initialized</td></tr> <tr><td>E3</td><td>K_p setting, positioner hunts</td></tr> <tr><td>E4</td><td>Transit time too fast</td></tr> <tr><td>E5</td><td>Standstill detection not possible</td></tr> <tr><td>E6</td><td>Travel not reached</td></tr> <tr><td>E7</td><td>Actuator not moving</td></tr> <tr><td>E8</td><td>Travel signal at lower limit</td></tr> <tr><td>E9 ... E15</td><td>Internal error, see EB 8394</td></tr> </tbody> </table>		Error description:		E0	Zero point error	E1	Reading and INIT values are not identical	E2	Positioner not initialized	E3	K_p setting, positioner hunts	E4	Transit time too fast	E5	Standstill detection not possible	E6	Travel not reached	E7	Actuator not moving	E8	Travel signal at lower limit	E9 ... E15	Internal error, see EB 8394
P10*	End position w <	ON																																																							
P11*	End position w >	OFF																																																							
P12*	Switching point A1	2 %																																																							
P13*	Switching point A2	98 %																																																							
P14	Info w/manual w																																																								
P15	Start INIT																																																								
P16*	Calibrate zero point																																																								
P17	MAN Manual mode																																																								
P18	RST Reset																																																								
P19	LOCK Enable configuration																																																								
P20	Firmware version																																																								
Error description:																																																									
E0	Zero point error																																																								
E1	Reading and INIT values are not identical																																																								
E2	Positioner not initialized																																																								
E3	K_p setting, positioner hunts																																																								
E4	Transit time too fast																																																								
E5	Standstill detection not possible																																																								
E6	Travel not reached																																																								
E7	Actuator not moving																																																								
E8	Travel signal at lower limit																																																								
E9 ... E15	Internal error, see EB 8394																																																								

BA_87_02_EN_MJ_4017

9. SPARE PARTS

When ordering accessories or spare parts, make sure to observe the specifications on the name plate of the positioner. The actual technical data of the positioner and the power supply requirements are the specifications indicated on the name plate.



Faulty or incorrect spare parts cause damage!

Attention

Spare parts must comply with the technical requirements specified by the manufacturer.

Always use original spare parts!

10. DECOMMISSIONING AND DISPOSAL



Risk of fatal injury due to ineffective explosion protection!

Danger

Explosion protection is no longer ensured when opening the positioner's housing cover. For mounting and installation in hazardous areas observe EN 60079-14, VDE 0165 Part 1.



Process disruption due to interruption of the control!

Attention

Do not mount or service the positioner while a process is in progress. Close shut-off devices before proceeding.

10.1 Decommissioning

To decommission the positioner before removal, proceed as follows:

1. Disconnect and lock the supply pressure and air supply.
2. Open the positioner's housing cover and disconnect the wires for the electrical supply.

10.2 Disassembling the positioner

1. Disconnect the wires for the electrical supply from the positioner.
2. Disconnect the wires for supply pressure and air supply.
3. To disassemble the positioner, loosen the three fastening screws on the positioner.

10.3 Disposal

- Dispose of the positioner in accordance with applicable, country-specific regulations and laws.
- Do not dispose of components, lubricants, and hazardous substances with household waste.

11. DIMENSIONS AND MOUNTING EXAMPLES

11.1 Dimensions Baelz 87

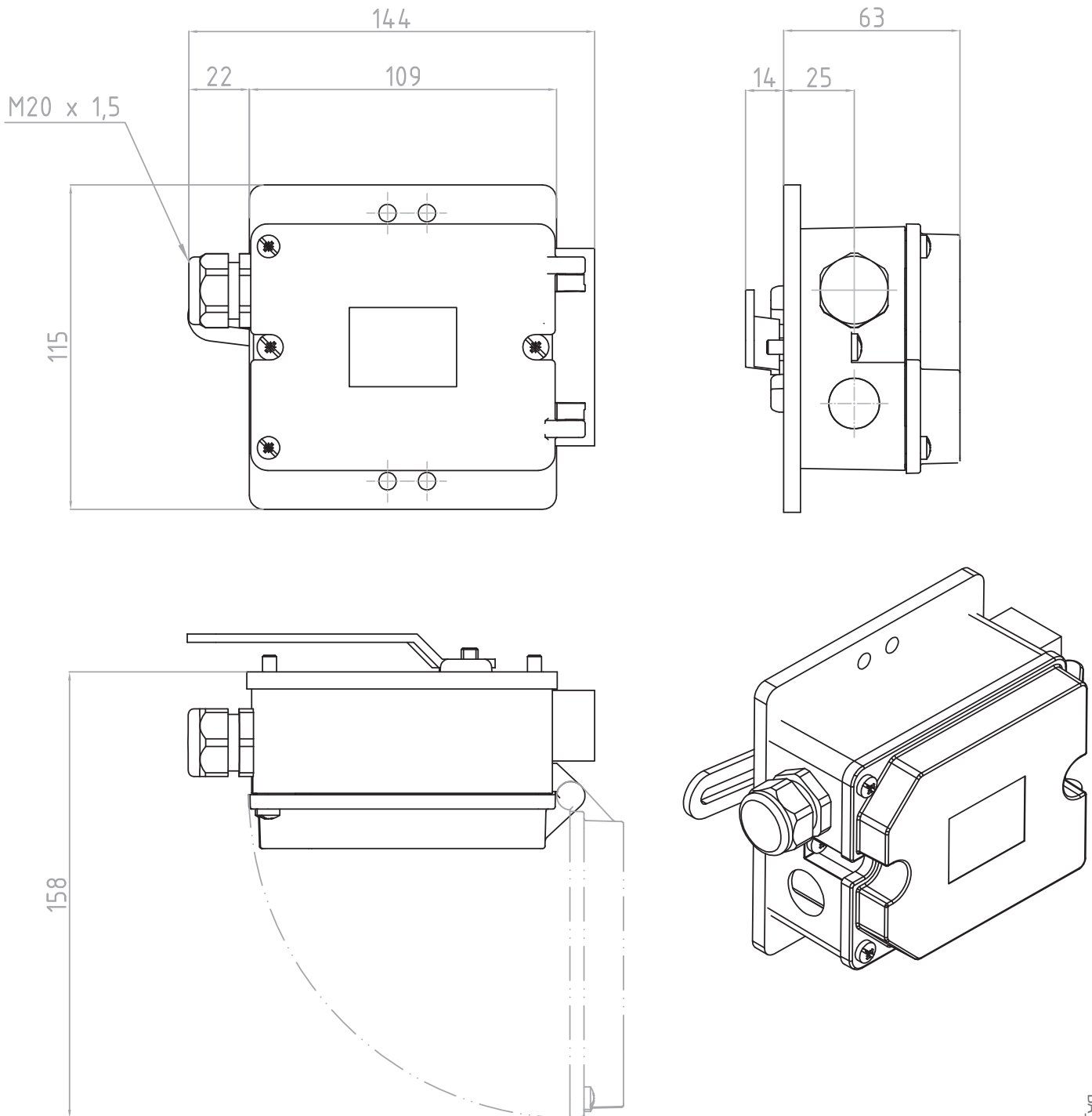
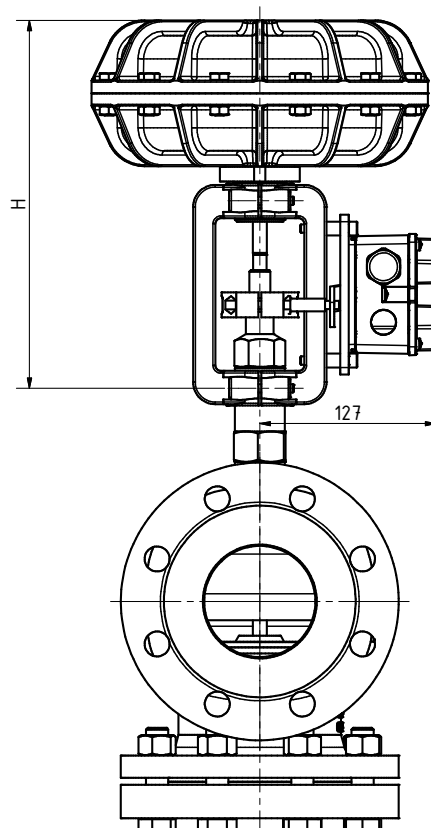
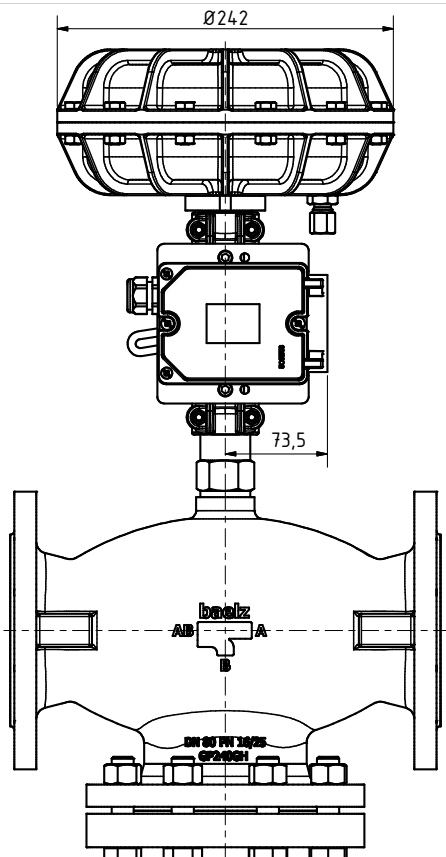
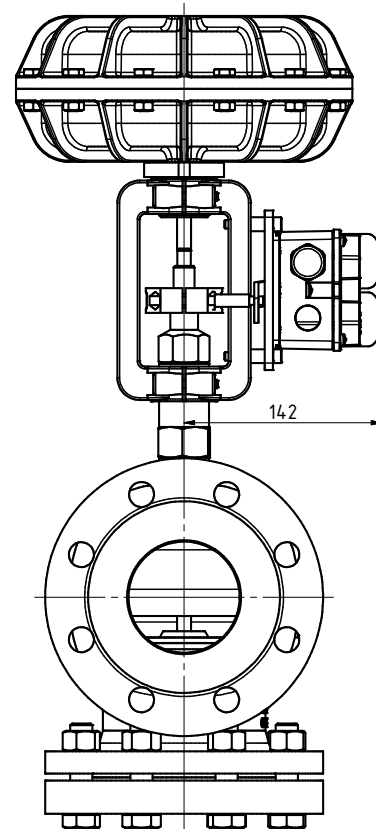
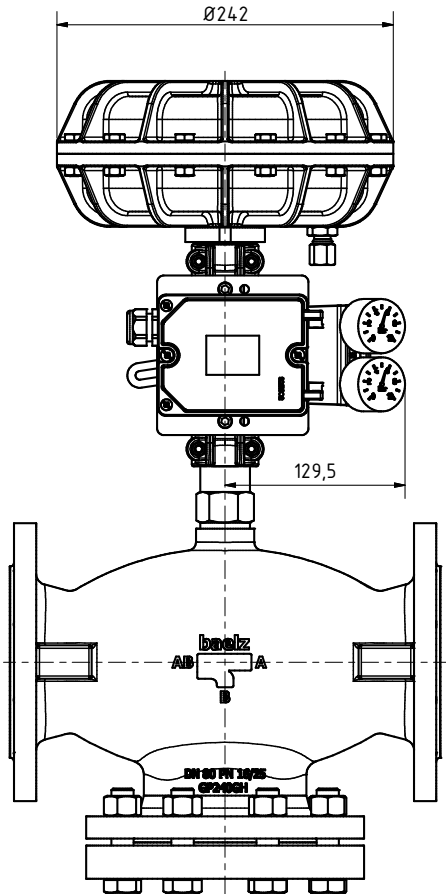

Fig. 14: Dimensions Baelz 87

BA_87_02_EN_MJ_4017

11.2 Baelz 87 mounted to Baelz 373 P21/P21-V6/P22 actuators



Actuator 373-	H (mm)
P21	268
P21-V6	304
P22	322

11.3 Baelz 87 mounted to Baelz 373 P21/P21-V6/P22 actuators

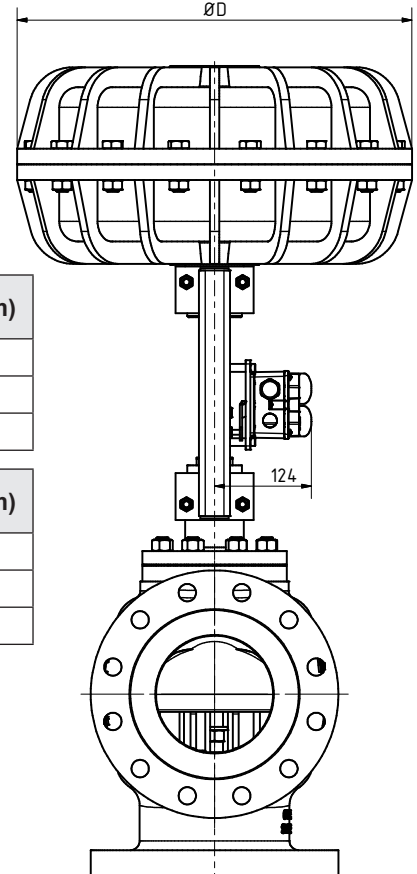
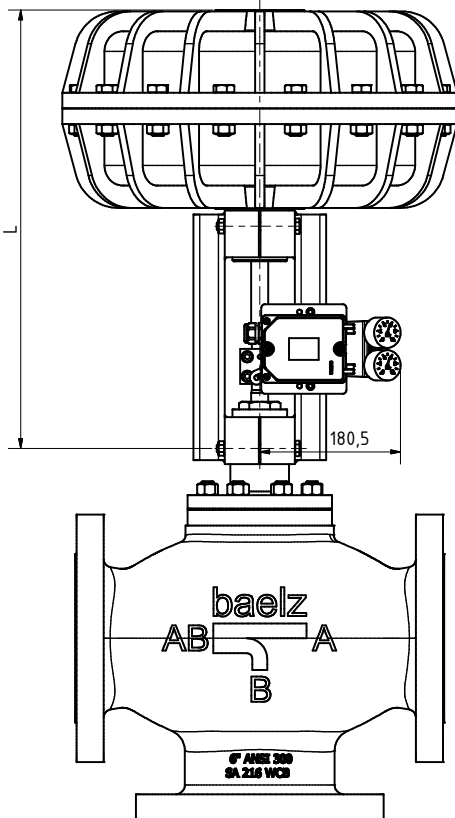
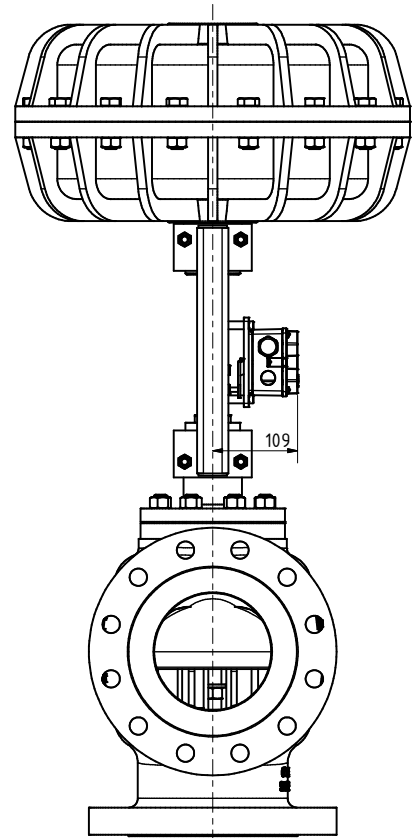
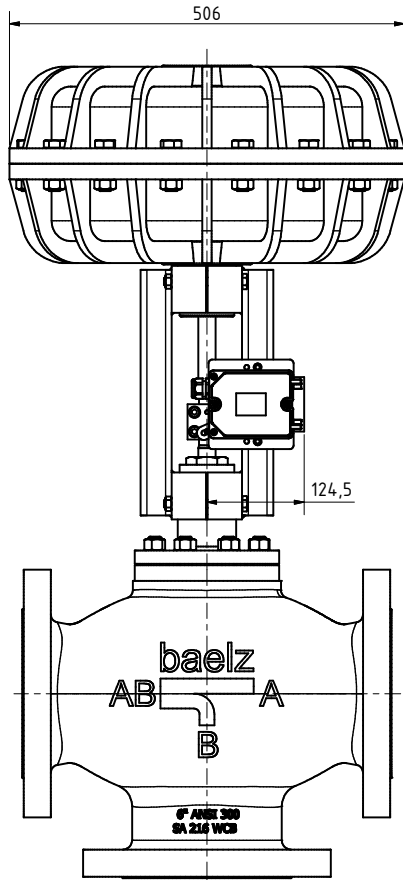

Actuator 373- (S41)	L (mm)	ØD (mm)
P31	509	384
P41	562	506
P41-V6	687	506

Actuator 373- (S41-C)	L (mm)	ØD (mm)
P31	989	384
P41	1042	506
P41-V6	1167	506

Technical specifications subject to change without notice

Observe copyright protection ISO 16016

W. Bälz & Sohn GmbH & Co.
Phone +49 (0)7131 15 00 0

Koepffstrasse 5
Fax +49 (0)7131 15 00 21

74076 Heilbronn
www.baelz.de

Germany
mail@baelz.de