

## Saunders<sup>®</sup> Tee Body for Flow Diversion and Sampling Applications

[www.cranecpe.com](http://www.cranecpe.com)

The Saunders<sup>®</sup> Tee Body combines a valve body and tee fitting in a single design manufactured from a single billet. This results in a valve body without internal fabrication welds for maximum integrity.

Key features include:

- 1 Zero deadleg design fully drains mainline
- 2 No internal fabrication welds
- 3 Optional integral sample ports available to permit realtime sampling of WFI without breaking a sterile use point connection



Also available with  
U-Bend style design for  
Point of Use installations

# Tee Bodies Imperial Dimensions Tube OD ASME BPE

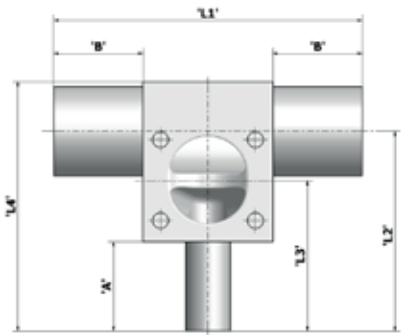

FOR DIMENSIONS L2 BW, L3 BW and A BW  
BW - BUTT WELD

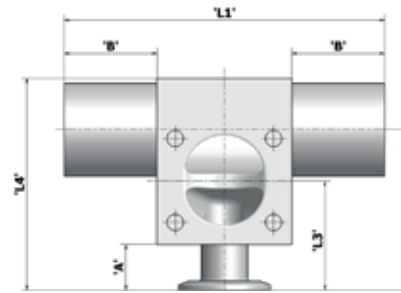

FOR DIMENSIONS L2 HC, L3 HC, L4 HC and A HC  
HC - HYGIENIC CLAMP

SIZE	M/LINE	L1	L2 BW	L2 HC	L3 BW	L3 HC	L4 BW	L4 HC	A BW	A HC	B
0.25	0.25	5.46	2.86	1.84	2.72	1.69	3.43	2.41	2.00	0.98	2.00
	0.5	5.99	2.99	1.98	2.72	1.69	3.43	2.41	2.00	0.98	2.00
	0.75	5.99	3.11	2.09	2.72	1.69	3.62	2.61	2.00	0.98	2.00
	1.00	5.99	3.24	2.23	2.72	1.69	3.86	2.84	2.00	0.98	2.00
	1.5	5.99	3.48	2.47	2.72	1.69	4.37	3.35	2.00	0.98	2.00
	2.0	5.99	3.74	2.72	2.72	1.69	4.84	3.83	2.00	0.98	2.00
	2.5	5.99	3.99	2.98	2.72	1.69	5.35	4.34	2.00	0.98	2.00
	3.0	5.99	4.24	3.23	2.72	1.69	5.87	4.85	2.00	0.98	2.00
4.0	9.99	4.73	3.71	2.72	1.69	6.85	5.83	2.00	0.98	4.00	

SIZE	M/LINE	L1	L2 BW	L2 HC	L3 BW	L3 HC	L4 BW	L4 HC	A BW	A HC	B
0.25 (0.5)	0.5	5.99	2.99	1.98	2.72	1.69	3.43	2.41	2.00	0.98	2.00
	0.75	5.99	3.11	2.09	2.72	1.69	3.62	2.61	2.00	0.98	2.00
	1.00	5.99	3.24	2.22	2.72	1.69	3.82	2.80	2.00	0.98	2.00
	1.5	5.99	3.48	2.47	2.72	1.69	4.37	3.35	2.00	0.98	2.00
	2.0	5.99	3.76	2.75	2.72	1.69	4.88	3.87	2.00	0.98	2.00
	2.5	5.99	50.70	2.98	2.72	1.69	5.35	4.34	2.00	0.98	2.00
	3.0	5.99	53.80	3.22	2.72	1.69	5.87	4.85	2.00	0.98	2.00
	4.0	9.99	4.73	3.71	2.72	1.69	6.85	5.83	2.00	0.98	4.00

SIZE	M/LINE	L1	L2 BW	L2 HC	L3 BW	L3 HC	L4 BW	L4 HC	A BW	A HC	B
0.5	0.5	5.99	3.07	2.28	2.99	1.97	3.94	2.92	2.00	0.98	2.00
	0.75	5.99	3.08	2.40	2.99	1.97	3.94	2.92	2.00	0.98	2.00
	1.00	5.99	3.08	2.54	2.99	1.97	4.17	3.16	2.00	0.98	2.00
	1.5	5.99	3.09	2.81	2.99	1.97	4.69	3.67	2.00	0.98	2.00
	2.0	5.99	3.10	3.04	2.99	1.97	5.16	4.14	2.00	0.98	2.00
	2.5	5.99	3.11	3.29	2.99	1.97	5.67	4.65	2.00	0.98	2.00
	3.0	5.99	3.12	3.56	2.99	1.97	6.18	5.17	2.00	0.98	2.00
	4.0	9.99	3.14	4.02	2.99	1.97	7.17	6.15	2.00	0.98	4.00

SIZE	M/LINE	L1	L2 BW	L2 HC	L3 BW	L3 HC	L4 BW	L4 HC	A BW	A HC	B
0.75	0.75	6.54	3.57	2.56	3.15	2.13	4.29	3.28	2.00	0.98	2.00
	1.00	6.54	3.73	2.71	3.15	2.13	4.33	3.31	2.00	0.98	2.00
	1.5	6.54	3.95	2.93	3.15	2.13	4.84	3.83	2.00	0.98	2.00
	2.0	6.54	4.20	3.19	3.15	2.13	5.31	4.30	2.00	0.98	2.00
	2.5	6.54	4.46	3.45	3.15	2.13	5.79	4.77	2.00	0.98	2.00
	3.0	6.54	4.70	3.68	3.15	2.13	6.30	5.28	2.00	0.98	2.00
	4.0	10.54	5.20	4.19	3.15	2.13	7.60	6.58	2.00	0.98	4.00

SIZE	M/LINE	L1	L2 BW	L2 HC	L3 BW	L3 HC	L4 BW	L4 HC	A BW	A HC	B
1.0	1.00	6.54	3.97	2.96	3.39	2.36	4.96	3.94	2.00	0.98	2.00
	1.5	6.54	4.22	3.20	3.39	2.36	5.08	4.06	2.00	0.98	2.00
	2.0	6.54	4.47	3.46	3.39	2.36	5.59	4.57	2.00	0.98	2.00
	2.5	6.54	4.72	3.70	3.39	2.36	6.10	5.09	2.00	0.98	2.00
	3.0	6.54	4.97	3.96	3.39	2.36	6.61	5.60	2.00	0.98	2.00
	4.0	10.54	5.46	4.44	3.39	2.36	7.60	6.58	2.00	0.98	4.00

SIZE	M/LINE	L1	L2 BW	L2 HC	L3 BW	L3 HC	L4 BW	L4 HC	A BW	A HC	B
1.5	1.5	8.02	4.67	3.66	3.78	2.80	5.59	4.57	2.00	0.98	2.00
	2.0	8.02	4.98	3.96	3.78	2.80	6.14	5.13	2.00	0.98	2.00
	2.5	8.02	5.23	4.21	3.78	2.80	6.65	5.64	2.00	0.98	2.00
	3.0	8.02	5.48	4.46	3.78	2.80	7.12	6.10	2.00	0.98	2.00
	4.0	12.02	5.91	4.89	3.78	2.80	8.03	7.02	2.00	0.98	4.00

SIZE	M/LINE	L1	L2 BW	L2 HC	L3 BW	L3 HC	L4 BW	L4 HC	A BW	A HC	B
2.0	2.0	9.04	5.32	4.30	4.13	3.11	6.46	5.44	2.00	0.98	2.00
	2.5	9.04	5.61	4.59	4.13	3.11	7.01	5.99	2.00	0.98	2.00
	3.0	9.04	5.85	4.84	4.13	3.11	7.48	6.46	2.00	0.98	2.00
	4.0	13.04	6.29	5.27	4.13	3.11	8.54	7.53	2.00	0.98	4.00

SIZE	M/LINE	L1	L2 BW	L2 HC	L3 BW	L3 HC	L4 BW	L4 HC	A BW	A HC	B
2.5	2.5	150.0	6.08	6.05	4.62	4.59	7.56	7.53	2.00	1.97	2.00
	3.0	150.0	6.33	6.30	4.62	4.59	7.95	7.92	2.00	1.97	2.00
	4.0	154.0	6.81	6.78	4.62	4.59	8.94	8.91	2.00	1.97	4.00

SIZE	M/LINE	L1	L2 BW	L2 HC	L3 BW	L3 HC	L4 BW	L4 HC	A BW	A HC	B
3.0	3.0	11.48	6.98	6.95	5.15	5.12	8.58	8.55	2.00	0.98	2.00
	4.0	15.48	7.46	7.43	5.15	5.12	9.61	9.57	2.00	0.98	4.00

Size = Weir/Branch size  
M/Line = Main Line size  
All dimensions shown in inches

# Tee Bodies Metric Dimensions Tube OD ASME BPE

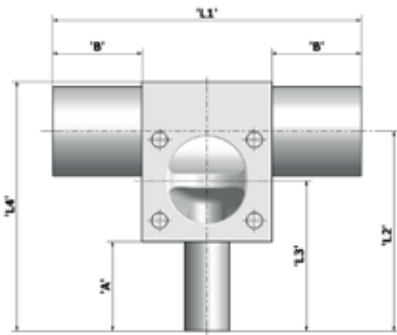

FOR DIMENSIONS L2 BW, L3 BW and A BW  
BW - BUTT WELD

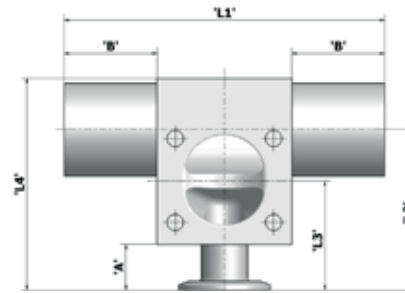

FOR DIMENSIONS L2 HC, L3 HC, L4 HC and A HC  
HC - HYGIENIC CLAMP

SIZE	M/ LINE	L1	L2 BW	L2 HC	L3 BW	L3 HC	L4 BW	L4 HC	A BW	A HC	B
8	8	139	73	47	69	43	87	61	50.8	25.0	50.8
	15	152	76	50	69	43	87	61	50.8	25.0	50.8
	20	152	79	53	69	43	92	66	50.8	25.0	50.8
	25	152	82	57	69	43	98	72	50.8	25.0	50.8
	40	152	89	63	69	43	111	85	50.8	25.0	50.8
	50	152	95	69	69	43	123	97	50.8	25.0	50.8
	65	152	101	76	69	43	136	110	50.8	25.0	50.8
	80	152	108	82	69	43	149	123	50.8	25.0	50.8
100	254	120	94	69	43	174	148	50.8	25.0	101.6	

SIZE	M/ LINE	L1	L2 BW	L2 HC	L3 BW	L3 HC	L4 BW	L4 HC	A BW	A HC	B
8 (15)	15	152	76	50	69	43	87	61	50.8	25.0	50.8
	20	152	79	53	69	43	92	66	50.8	25.0	50.8
	25	152	82	56	69	43	97	71	50.8	25.0	50.8
	40	152	89	63	69	43	111	85	50.8	25.0	50.8
	50	152	96	70	69	43	124	98	50.8	25.0	50.8
	65	152	101	76	69	43	136	110	50.8	25.0	50.8
	80	152	108	82	69	43	149	123	50.8	25.0	50.8
	100	254	120	94	69	43	174	148	50.8	25.0	101.6

SIZE	M/ LINE	L1	L2 BW	L2 HC	L3 BW	L3 HC	L4 BW	L4 HC	A BW	A HC	B
15	15	152	84	58	76	50	100	74	50.8	25.0	50.8
	20	152	87	61	76	50	100	74	50.8	25.0	50.8
	25	152	90	64	76	50	106	80	50.8	25.0	50.8
	40	152	97	71	76	50	119	93	50.8	25.0	50.8
	50	152	103	77	76	50	131	105	50.8	25.0	50.8
	65	152	109	84	76	50	144	118	50.8	25.0	50.8
	80	152	116	91	76	50	157	131	50.8	25.0	50.8
	100	254	128	102	76	50	182	156	50.8	25.0	101.6

SIZE	M/ LINE	L1	L2 BW	L2 HC	L3 BW	L3 HC	L4 BW	L4 HC	A BW	A HC	B
20	20	166	91	65	80	54	109	83	50.8	25.0	50.8
	25	166	95	69	80	54	110	84	50.8	25.0	50.8
	40	166	100	75	80	54	123	97	50.8	25.0	50.8
	50	166	107	81	80	54	135	109	50.8	25.0	50.8
	65	166	113	88	80	54	147	121	50.8	25.0	50.8
	80	166	119	94	80	54	160	134	50.8	25.0	50.8
	100	268	132	106	80	54	193	167	50.8	25.0	101.6

SIZE	M/ LINE	L1	L2 BW	L2 HC	L3 BW	L3 HC	L4 BW	L4 HC	A BW	A HC	B
25	25	176	101	75	86	60	126	100	50.8	25.0	50.8
	40	176	107	81	86	60	129	103	50.8	25.0	50.8
	50	176	114	88	86	60	142	116	50.8	25.0	50.8
	65	176	120	94	86	60	155	129	50.8	25.0	50.8
	80	176	126	101	86	60	168	142	50.8	25.0	50.8
	100	277	139	113	86	60	193	167	50.8	25.0	101.6

SIZE	M/ LINE	L1	L2 BW	L2 HC	L3 BW	L3 HC	L4 BW	L4 HC	A BW	A HC	B
40	40	204	119	93	96	71	142	116	50.8	25.0	50.8
	50	204	126	101	96	71	156	130	50.8	25.0	50.8
	65	204	133	107	96	71	169	143	50.8	25.0	50.8
	80	204	139	113	96	71	181	155	50.8	25.0	50.8
	100	305	150	124	96	71	204	178	50.8	25.0	101.6

SIZE	M/ LINE	L1	L2 BW	L2 HC	L3 BW	L3 HC	L4 BW	L4 HC	A BW	A HC	B
50	50	230	135	109	105	79	164	138	50.8	25.0	50.8
	65	230	143	117	105	79	178	152	50.8	25.0	50.8
	80	230	149	123	105	79	190	164	50.8	25.0	50.8
	100	331	160	134	105	79	217	191	50.8	25.0	101.6

SIZE	M/ LINE	L1	L2 BW	L2 HC	L3 BW	L3 HC	L4 BW	L4 HC	A BW	A HC	B
65	65	248	154.4	153.6	117.3	116.5	192.0	191.2	50.8	50.0	50.8
	80	248	160.8	160.0	117.3	116.5	202.0	201.2	50.8	50.0	50.8
	100	349	173.0	172.2	117.3	116.5	227.0	226.2	50.8	50.0	101.6

Size = Weir/Branch size  
M/Line = Main Line size  
All dimensions shown in millimeters

SIZE	M/ LINE	L1	L2 BW	L2 HC	L3 BW	L3 HC	L4 BW	L4 HC	A BW	A HC	B
80	80	292	177.3	176.5	130.8	130.0	218.0	217.2	50.8	50.0	50.8
	100	393	189.6	188.8	130.8	130.0	244.0	243.2	50.8	50.0	101.6

# Tee Bodies Tube specification DIN 11866 Series A/DIN 11850

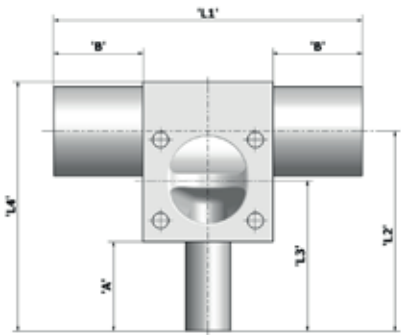

FOR DIMENSIONS L2 BW, L3 BW, L4 BW and A BW  
BW - BUTT WELD

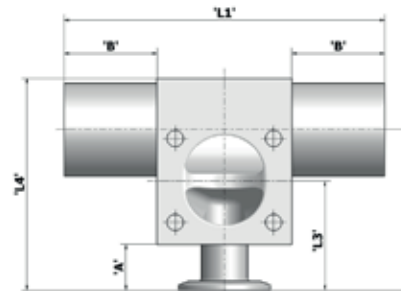

FOR DIMENSIONS L2 HC, L3 HC, L4 HC and A HC  
HC - HYGIENIC CLAMP

SIZE	M/LINE	L1	L2 BW	L2 HC	L3 BW	L3 HC	L4 BW	L4 HC	A BW	A HC	B
8 (10)	10	139	76	51	69	43	87	61	50.8	25.0	50.8
	15	139	79	54	69	43	92	66	50.8	25.0	50.8
	20	139	81	56	69	43	96	70	50.8	25.0	50.8
	25	139	84	59	69	43	102	76	50.8	25.0	50.8
	32	139	87	62	69	43	108	82	50.8	25.0	50.8
	40	139	90	65	69	43	116	90	50.8	25.0	50.8
	50	139	96	71	69	43	126	100	50.8	25.0	50.8
	65	139	104	79	69	43	142	117	50.8	25.0	50.8
	80	152	112	86	69	43	157	132	50.8	25.0	50.8
100	254	121	96	69	43	176	151	50.8	25.0	101.6	

SIZE	M/LINE	L1	L2 BW	L2 HC	L3 BW	L3 HC	L4 BW	L4 HC	A BW	A HC	B
15	15	152	87	61	76	50	101	75	50.8	25.0	50.8
	20	152	89	63	76	50	104	78	50.8	25.0	50.8
	25	152	92	66	76	50	109	83	50.8	25.0	50.8
	32	152	95	69	76	50	116	90	50.8	25.0	50.8
	40	152	98	72	76	50	122	96	50.8	25.0	50.8
	50	152	104	78	76	50	134	108	50.8	25.0	50.8
	65	152	112	86	76	50	151	125	50.8	25.0	50.8
	80	152	120	94	76	50	165	139	50.8	25.0	50.8
	100	254	129	103	76	50	184	158	50.8	25.0	101.6

SIZE	M/LINE	L1	L2 BW	L2 HC	L3 BW	L3 HC	L4 BW	L4 HC	A BW	A HC	B
20	20	166	93	68	80	54	109	83	50.8	25.0	50.8
	25	166	96	71	80	54	114	88	50.8	25.0	50.8
	32	166	99	74	80	54	120	94	50.8	25.0	50.8
	40	166	102	77	80	54	125	99	50.8	25.0	50.8
	50	166	108	83	80	54	138	112	50.8	25.0	50.8
	65	166	116	91	80	54	154	129	50.8	25.0	50.8
	80	166	124	98	80	54	169	144	50.8	25.0	50.8
	100	268	133	108	80	54	188	163	50.8	25.0	101.6

SIZE	M/LINE	L1	L2 BW	L2 HC	L3 BW	L3 HC	L4 BW	L4 HC	A BW	A HC	B
25	25	176	103	77	86	60	126	100	50.8	25.0	50.8
	32	176	106	80	86	60	126	101	50.8	25.0	50.8
	40	176	109	83	86	60	132	106	50.8	25.0	50.8
	50	176	115	89	86	60	144	119	50.8	25.0	50.8
	65	176	123	97	86	60	161	135	50.8	25.0	50.8
	80	176	130	105	86	60	175	149	50.8	25.0	50.8
	100	277	140	114	86	60	194	168	50.8	25.0	101.6

SIZE	M/LINE	L1	L2 BW	L2 HC	L3 BW	L3 HC	L4 BW	L4 HC	A BW	A HC	B
40	40	204	120	95	96	71	144	118	50.8	25.0	50.8
	50	204	126	101	96	71	156	130	50.8	25.0	50.8
	65	204	134	109	96	71	172	147	50.8	25.0	50.8
	80	204	142	116	96	71	187	162	50.8	25.0	50.8
	100	305	151	126	96	71	206	181	50.8	25.0	101.6

SIZE	M/LINE	L1	L2 BW	L2 HC	L3 BW	L3 HC	L4 BW	L4 HC	A BW	A HC	B
50	50	230	136	111	105	79	165	139	50.8	25.0	50.8
	65	230	144	118	105	79	183	157	50.8	25.0	50.8
	80	230	152	126	105	79	197	172	50.8	25.0	50.8
	100	331	161	135	105	79	215	189	50.8	25.0	101.6

SIZE	M/LINE	L1	L2 BW	L2 HC	L3 BW	L3 HC	L4 BW	L4 HC	A BW	A HC	B
65	65	248	157.3	156.5	117.3	116.5	195.8	195.0	50.8	50.0	50.8
	80	248	164.8	164.0	117.3	116.5	210.3	209.5	50.8	50.0	50.8
	100	349	174.3	173.5	117.3	116.5	229.3	228.5	50.8	50.0	101.6

SIZE	M/LINE	L1	L2 BW	L2 HC	L3 BW	L3 HC	L4 BW	L4 HC	A BW	A HC	B
80	80	292	179.3	178.5	130.8	130.0	224.8	224.0	50.8	50.0	50.8
	100	393	188.8	188.0	130.8	130.0	243.8	243.0	50.8	50.0	101.6

Size = Weir/Branch size  
M/Line = Main Line size  
All dimensions shown in millimeters

# Tee Bodies Tube Specification DIN11866 Series B/ISO 1127 Series 1

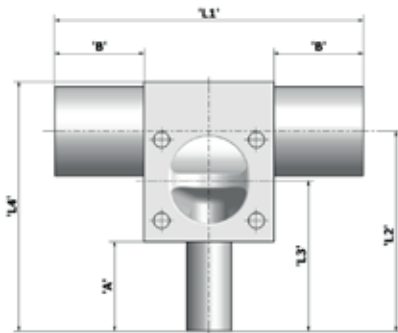

FOR DIMENSIONS L2 BW, L3 BW, L4 BW and A BW  
BW - BUTT WELD

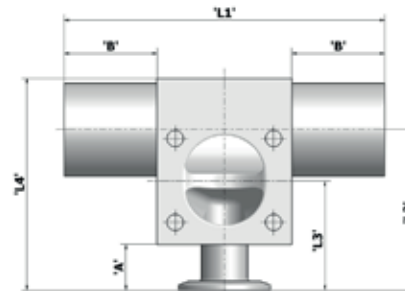

FOR DIMENSIONS L2 HC, L3 HC, L4 HC and A HC  
HC - HYGIENIC CLAMP

SIZE	M/ LINE	L1	L2 BW	L2 HC	L3 BW	L3 HC	L4 BW	L4 HC	A BW	A HC	B
20	20	166	95	69	80	54	112	86	50.8	25.0	50.8
	25	166	98	72	80	54	118	92	50.8	25.0	50.8
	32	166	103	77	80	54	127	101	50.8	25.0	50.8
	40	166	106	80	80	54	133	107	50.8	25.0	50.8
	50	166	111	85	80	54	144	118	50.8	25.0	50.8
	65	166	119	93	80	54	160	134	50.8	25.0	50.8
	80	166	125	99	80	54	173	147	50.8	25.0	50.8
	100	268	138	112	80	54	199	173	50.8	25.0	101.6

SIZE	M/ LINE	L1	L2 BW	L2 HC	L3 BW	L3 HC	L4 BW	L4 HC	A BW	A HC	B
25	25	176	105	79	86	60	125	99	50.8	25.0	50.8
	32	176	109	83	86	60	139	113	50.8	25.0	50.8
	40	176	115	89	86	60	139	113	50.8	25.0	50.8
	50	176	118	92	86	60	150	124	50.8	25.0	50.8
	65	176	125	100	86	60	166	141	50.8	25.0	50.8
	80	176	132	106	86	60	180	154	50.8	25.0	50.8
	100	277	144	119	86	60	205	179	50.8	25.0	101.6

SIZE	M/ LINE	L1	L2 BW	L2 HC	L3 BW	L3 HC	L4 BW	L4 HC	A BW	A HC	B
40	40	204	124	98	96	71	151	125	50.8	25.0	50.8
	50	204	129	103	96	71	162	136	50.8	25.0	50.8
	65	204	137	111	96	71	178	152	50.8	25.0	50.8
	80	204	143	117	96	71	191	165	50.8	25.0	50.8
	100	305	156	130	96	71	216	190	50.8	25.0	101.6

SIZE	M/ LINE	L1	L2 BW	L2 HC	L3 BW	L3 HC	L4 BW	L4 HC	A BW	A HC	B
50	50	230	139	113	105	79	173	147	50.8	25.0	50.8
	65	230	147	121	105	79	188	162	50.8	25.0	50.8
	80	230	153	127	105	79	201	175	50.8	25.0	50.8
	100	331	166	140	105	79	227	201	50.8	25.0	101.6

SIZE	M/ LINE	L1	L2 BW	L2 HC	L3 BW	L3 HC	L4 BW	L4 HC	A BW	A HC	B
65	65	248	159.8	159.0	117.3	116.5	200.8	200.0	50.8	25.0	50.8
	80	248	166.2	165.4	117.3	116.5	213.6	212.8	50.8	25.0	50.8
	100	349	178.9	178.1	117.3	116.5	239.0	238.2	50.8	25.0	101.6

SIZE	M/ LINE	L1	L2 BW	L2 HC	L3 BW	L3 HC	L4 BW	L4 HC	A BW	A HC	B
80	80	292	180.7	179.9	130.8	130.0	228.8	228.0	50.8	50.0	50.8
	100	393	193.4	192.6	130.8	130.0	253.8	253.0	50.8	50.0	101.6

Size = Weir/Branch size  
M/Line = Main Line size  
All dimensions shown in millimeters

# Saunders® Tee Body for Flow Diversion and Sampling Applications

The weir is machined in close proximity to the side wall of the tube to reduce deadleg and stagnant areas. The weir is also located at the drain point of the tube to fully drain the valve and associated horizontal tubing.

The Saunders® Tee Body meets cGMP requirements and is ideal for systems subjected to CIP and SIP processes due to minimal deadleg and free draining features.

Saunders® full portfolio of drawing data can be accessed at [www.saundersdrawings.com](http://www.saundersdrawings.com) in both 2D and 3D file format. Specific Tee Valve drawings are referenced below.

## Tube OD ASME BPE (Metric)

SIZE	DRG No (BW)	DRG No (HC)
8	WEB-004	WEB-013
8 (15)	WEB-005	WEB-014
15	WEB-006	WEB-015
20	WEB-007	WEB-016
25	WEB-008	WEB-017
40	WEB-009	WEB-018

## DIN 11866 Series A/DIN 11850

SIZE	DRG No (BW)	DRG No (HC)
8 (10)	WEB-097	WEB-105
15	WEB-098	WEB-106
20	WEB-099	WEB-107
25	WEB-100	WEB-108
40	WEB-101	WEB-109

## Tube OD ASME BPE Imperial

SIZE	DRG No (BW)	DRG No (HC)
0.25	WEB-004	WEB-013
0.25(0.5)	WEB-005	WEB-014
0.5	WEB-006	WEB-015
0.75	WEB-007	WEB-016
1.0	WEB-008	WEB-017
1.5	WEB-009	WEB-018
2.0	WEB-010	WEB-019
2.5	WEB-011	WEB-020
3.0	WEB-012	WEB-021

## DIN 11866 Series B/ISO 1127

SIZE	DRG No (BW)	DRG No (HC)
8	WEB-073	WEB-082
15	WEB-074	WEB-083
20	WEB-075	WEB-084
25	WEB-076	WEB-085
40	WEB-077	WEB-086

Weld ends are fabricated from controlled sulfur tube to facilitate orbital welding and to comply with ASME BPE standard for weld chemistry. Weld ends have overall length and control portion in compliance with ASME BPE to allow use with all common orbital weld heads.

## Size Range

- Main line: DN8 (0.25") – DN150 (6.00")
- Branch: DN8 (0.25") – DN150 (6.00")

## Materials – Body

- 316L ASTM A-479
- DIN 1.4435
- AL6XN
- Hastelloy®
- Other grades on request

## Materials – Weld Ends

- 316L ASTM A269/A270, DIN11850
- Controlled Sulfur 0.005%-0.017% ASME BPE

## End Connections

- Tube OD per ASME BPE, BS, ISO 1127, DN118650, SMS
- Hygienic Clamp

## Surface Finish ID

- All ASME BPE finishes
- Saunders®: Satin and Mirror

## Bonnets and Actuators

- Uses standard Saunders® manual bonnets
- Uses standard Saunders® actuators

## Diaphragms

Available with Saunders® Life Science FDA conforming

diaphragms

## Compliance

Complies with cGMP and ASME BPE

## Typical Applications

Sampling, Point of Use, Drain, Flow Diversion

[www.cranecpe.com](http://www.cranecpe.com)



Crane ChemPharma & Energy, Saunders® • 4526 Research Forest Dr, Suite 400, The Woodlands, TX 77381 • USA  
PH: (936)-588-8360 • [SaundersOrders@CraneCPE.com](mailto:SaundersOrders@CraneCPE.com), [SaundersQuotes@CraneCPE.com](mailto:SaundersQuotes@CraneCPE.com)

IMPORTANT: CRANE Co. and its subsidiaries are not responsible for the accuracy, compliance, and legality of material contained in this datasheet offered in print, on the company websites, or via any external links, or third party sites.