

NRG 1...-50 with four-pole connector

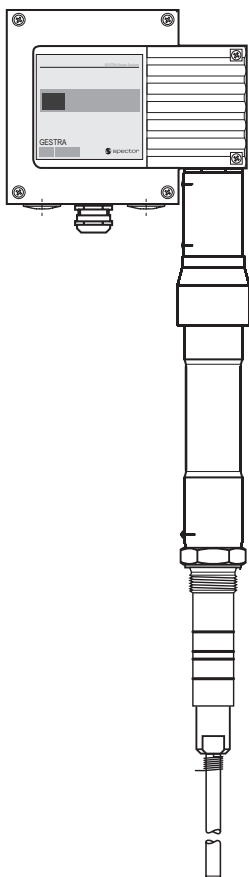

NRG 111-50F with terminal box made from aluminium

Water Level Limiter

Level Electrode

NRG 16-50, NRG 17-50, NRG 19-50, NRG 111-50

Description

The level electrodes NRG 1...-50 are used in conjunction with level switch NRS 1-50 as water level limiters for steam boiler plants and (pressurised) hot water installations.

Water level limiters switch off the heating when the water level falls below the set minimum level (low water).

Function

When the water level falls below the low level, the level electrode is exposed and a low level alarm is triggered in the level switch NRS 1-50. This switchpoint "Low water level (LW)" is determined by the length of the electrode tip. The electrode operation is based on the conductive measuring principle using the electrical conductivity of the water for signalling water level.

The self-monitoring function ensures that an alarm will also be triggered if the electrode insulation is contaminated or has developed a leak and/or if there is a malfunction in the electrical connection.

The level electrode is installed inside steam boilers, vessels or inlet lines of hot-water systems. The protection tube provided on site ensures the function.

One level electrode NRS 1...-50 can be installed together with one GESTRA level electrode, one level switch or transmitter for water level control and low level alarm in one single protection tube or level pot.

If the level electrode is installed in a level pot outside the boiler, make sure that the connecting lines are rinsed regularly. In addition, the logic unit SRL is required to monitor the purging times and the purging sequence.

If the connecting lines for steam ≥ 40 mm and water ≥ 100 mm the installation is considered as "inside". In this case the purging process does not have to be monitored.

Directives and Standards

Pressure Equipment Directive (PED) 2014/68/EU

Water level limiters are safety accessories as defined in the Pressure Equipment Directive (PED). The level electrode NRG 1...-50 in conjunction with level switch NRS 1-50 is EC type approved according to EN 12952/EN 12953. These Directives state, among other things, the requirements made on limiting systems and equipment for steam boiler plants and (pressurised) hot-water installations.

Functional Safety acc. to IEC 61508

The level electrodes NRG 1...-50, NRG 16-36 are certified acc. to IEC 61508 only if used in combination with level switch NRS 1-50. This standard describes the functional safety of safety-related electrical/electronic/programmable electronic systems.

VdTÜV Bulletin "Wasserstand 100" (= Water Level 100)

The level electrodes NRG 1-50, NRG 1...-11 and NRG 16-36 in conjunction with the level switch NRS 1-50 are type approved according to the VdTÜV Bulletin "Water Level 100".

UL/cUL (CSA) Approval

The equipment meets the requirements of Directives: UL 508 and CSA C22.2 No. 14-13, Standards for Industrial Control Equipment. File E243189.

Directives and Standards

ATEX (Atmosphère Explosible)

The level electrodes NRG 1...-50, NRG 1...-11 and NRG 16-36 are simple items of electrical equipment as specified in EN 60079-11 section 5.7. According to the European Directive 2014/34/EU the equipment must be equipped with approved Zener barriers if used in potentially explosive areas. Applicable in Ex-zones 1, 2 (1999/92/EC).

The equipment does not bear an Ex-marking. Note that the requirements of the IEC 61508 are not met if the NRG 1...-50, NRG 1...-11 and NRG 16-36 + Zener barriers + NRS 1-50 are interconnected!

Technical Data

Service pressure

NRG 16-50, PN 40, 32 bar at 238 °C
 NRG 17-50, PN 63, 60 bar at 275 °C
 NRG 19-50, PN 160, 100 bar at 311 °C
 NRG 111-50, PN 320, 183 bar at 357 °C

Mechanical connection

Screwed G $\frac{3}{4}$ A, ISO 228 (NRG 16-50, NRG 17-50, NRG 19-50)
 Screwed G 1 A, ISO 228 (NRG 111-50)

Materials

Sheath: 1.4301 X5 CrNi18-10
 Screw-in body: 1.4571 X6 CrNiMoTi 17-12-2 (NRG 16-50, NRG 17-50, NRG 19-50)
 Screw-in body: 1.4529, X1NiCrMoCuN25-20-7 (NRG 111-50)
 Measuring electrode: 1.4571 X6 CrNiMoTi 17-12-2 (NRG 16-50, NRG 17-50, NRG 19-50)
 Measuring electrode: 1.4122, X39CrMo17-1 (NRG 111-50)
 Electrode tip: 1.4401 X5 CrNiMo 17-12-2
 Electrode insulation: Gylon® (NRG 16-50, NRG 17-50, NRG 19-50)
 Electrode insulation: special ceramic (NRG 111-50)
 NRG 1...-50: Four-pole connector: polyamid (PA)
 NRG 1...-50F: Terminal box 3.2161 G AISi8Cu3

Lengths supplied

500 mm, 1000 mm, 1500 mm, 2000 mm, 2500 mm, 3000 mm

ph value

Max. admissible: 10 (NRG 111-50)

Electrical connection

NRG 1...-50: Four-pole connector, cable gland M16
 NRG 1...-50F: Aluminium terminal box, cable gland M20

Protection

IP 65 to DIN EN 60529

Max. admissible ambient temperature

70 °C

Weight

Approx. 1.2 kg (without extension)
 (NRG 16-50, NRG 17-50, NRG 19-50)
 Approx. 1.8 kg (without extension)
 (NRG 111-50)

Important Notes

Dimensions

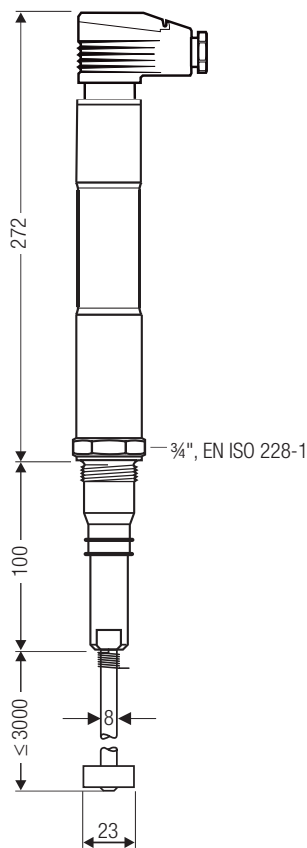

Fig. 1 NRG 16-50, NRG 17-50, NRG 19-50 with four-pole connector and measuring surface extension

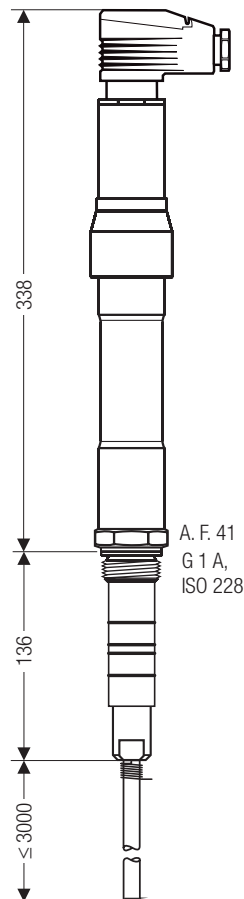

Fig. 2 NRG 111-50 with four-pole connector

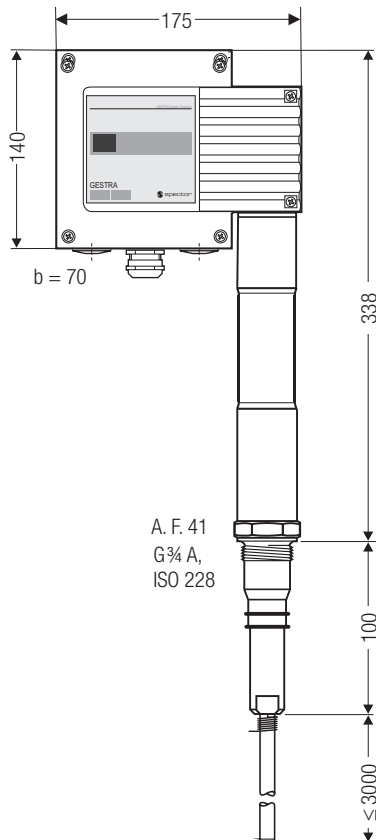

Fig. 3 NRG 16-50F, NRG 17-50F, NRG 19-50F with terminal box made from aluminium

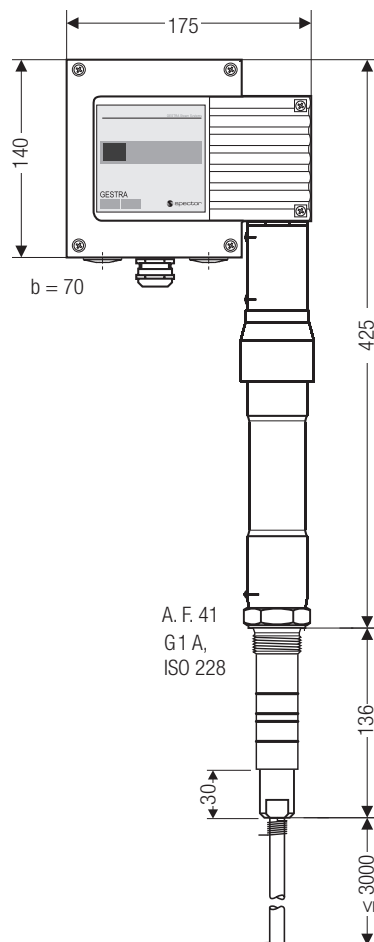

Fig. 4 NRG 111-50F with terminal box made from aluminium

Installation

- **One** level electrode NRG 1...-50 can be installed together with one GESTRA level electrode, one level switch or transmitter for water level control or low level alarm in one single protection tube or level pot (inside diameter 100 mm). If the electrode NRG 1...-50 is installed inside the vessel, it must be at least 40 mm away from the upper vent hole.
- The installation of two water-level limiting electrodes NRG 1...-50 in one single standpipe is not allowed!
- The angle of inclination of the electrode must not exceed 45°, with the length of the electrode rod being limited to 1000 mm.
- If the level switch NRS 1-50 has a response sensitivity of 0.5 μS/cm please use a measuring surface extension.
- For outdoor installations please use level electrode NRG 1...-50 F. Level electrodes with this suffix (F) feature a terminal box made from aluminium.
- Use GESTRA hat flange if the level electrode **NRG 111-50** is to be installed in a flanged standpipe DN 50.

Electrical Connection

To connect the level electrode please use:

- For level switch NRS 1-50 with response sensitivity 10 μS: Screened multi-core control cable, min. conductor size 0.5 mm², e.g. LiYCY 4 x 0.5 mm², max. length 100 m.
- For level switch NRS 1-50 with response sensitivity 0.5 μS: Double-screened multi-core low-capacitance data cable, min. conductor size 0.5 mm², **Li2YCY PiMF 2 x 2 x 0.5 mm², max. length 30 m.**

Order & Enquiry Specification

GESTRA Level electrode NRG 1...-50

PN....., connection....., inspection.....

Length suppliedmm

Water Level Limiter

Level Electrode

**NRG 16-50, NRG 17-50,
NRG 19-50, NRG 111-50**

Key

- 1 Flange PN 40, PN 63, PN 160, PN 320
DN 50, DIN EN 1092-01 (for 1 electrode)
Flange PN 40, PN 63, PN 160, DN 100,
DIN EN 1092-01 (for 2 electrodes)
- 2 For the approval of the boiler standpipe with
connecting flange the relevant regulations must be
considered.
- 3 Vent hole
- 4 Electrode rod $d = 8 \text{ mm}$
- 5 Protection tube DN 80
(in France acc. to AFAQ ≥ 100)
- 6 Low water (LW)
- 7 Reducer DIN 2616-2,
K-88.9 x 3.2 - 42.4 x 2.6 W
- 8 High water (HW)
- 9 Electrode distance $\geq 14 \text{ mm}$ (air gap and creepage
distance)
- 10 GESTRA hat flange PN 320, DN 50,
DIN EN 1092-01
- 11 Standpipe / connecting flange DN 50
- 12 Protection tube DN 100
- 13 Reducer DIN 2616-2,
K-114.3 x 3.6 - 48.3 x 2.9 W
- 14 Level pot $\geq \text{DN } 80$

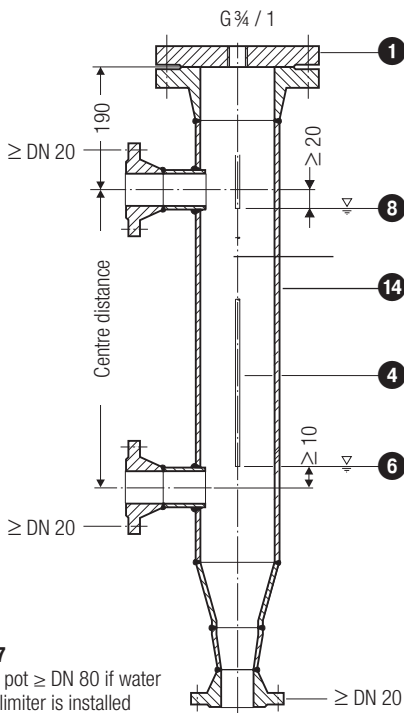

Fig. 7
Level pot $\geq \text{DN } 80$ if water
level limiter is installed
outside the boiler

Supply in accordance with our general terms of business.

Examples of installation

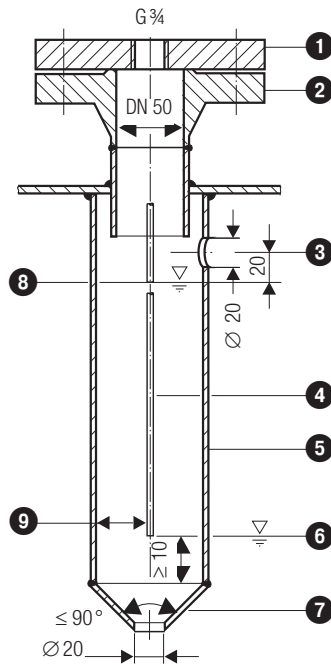

Fig. 5 Protection tube if electrode is used as internal
water-level limiter

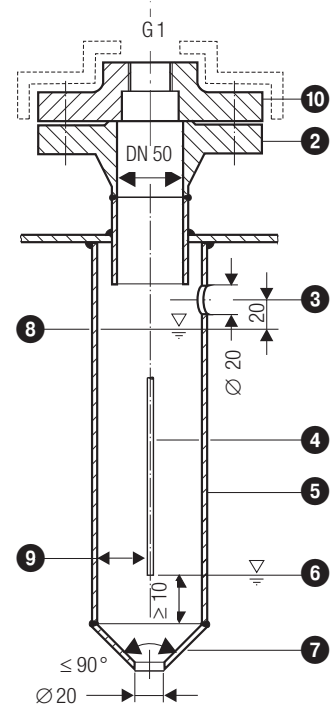

Fig. 6 Protection tube if electrode (NRG 111-50) is used as
internal water-level limiter

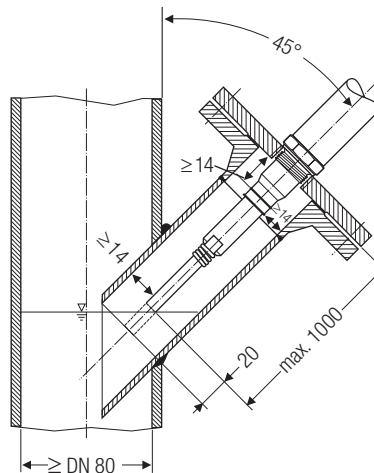

Fig. 8 Inclined installation, e. g. in ascending inlet
lines of hot-water installations or vessels
Standpipe/connecting flange DN 50

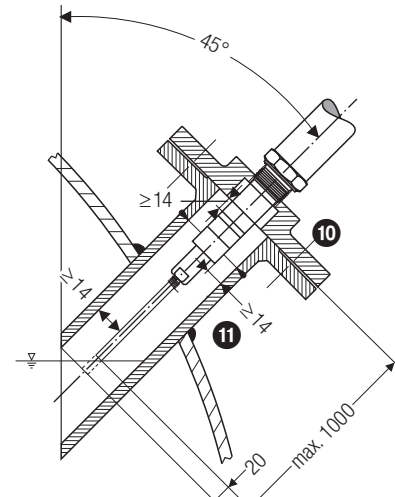

Fig. 9 Inclined installation, e. g. in steam boilers
Standpipe/connecting flange DN 50
(NRG 111-50)

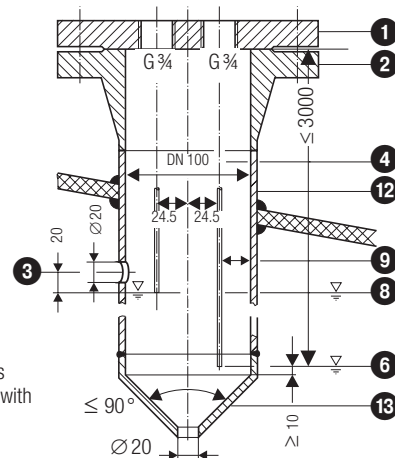

Fig. 10 Protection tube if electrode is used as
internal water level-limiter combined with
water level control or low level alarm

Alnab Armatur AB
Ögärdesvägen 4B
SE-433 30 Partille

Tel +46-31 449450
Email alnab@alnab.se
Web www.alnab.se

556312-9716

GESTRA®