

STOP GLOBE VALVE TYPE 412

CHARACTERISTIC:

Diameter	-	15 -200 mm;
Pressure	-	63 bar;
Temperature	-	up to 560°C (with PTFE sealing up to 200°C);
Medium	-	water, steam and other non-toxic, non aggressive liquid and gas media and engine fuel.

VERSIONS:

type / ends / body material / disc and disc ring / drive type

Example: 412 / --- / --- / --- / ---

Example: 412 / S / U / P / ---

Ends	Sign	Body material	Sign	Disc and disc ring	Sign	Drive type	Sign
Standard - flanged	---	(P2550GH) C 22.8	---	Standard	---	Hand wheel	---
Butt weld ends	S	or GP240GH		PTFE ring	P	AUMA drive	NA
Socket weld	SW	16Mo3 or G20Mo5	U	NBR ring	N	NWA drive	NW
Threaded	G	13CrMo4-5 or G17CrMo5-5	A	STELLIT ring	L	MODACT drive	NM
						Pneumatic drive	NP

APPLICATION:

Stop globe valve is designed to open and stop the flow. The valve is not supposed to be used as a regulating device. For regulation the version „R” with throttling plug should be applied.

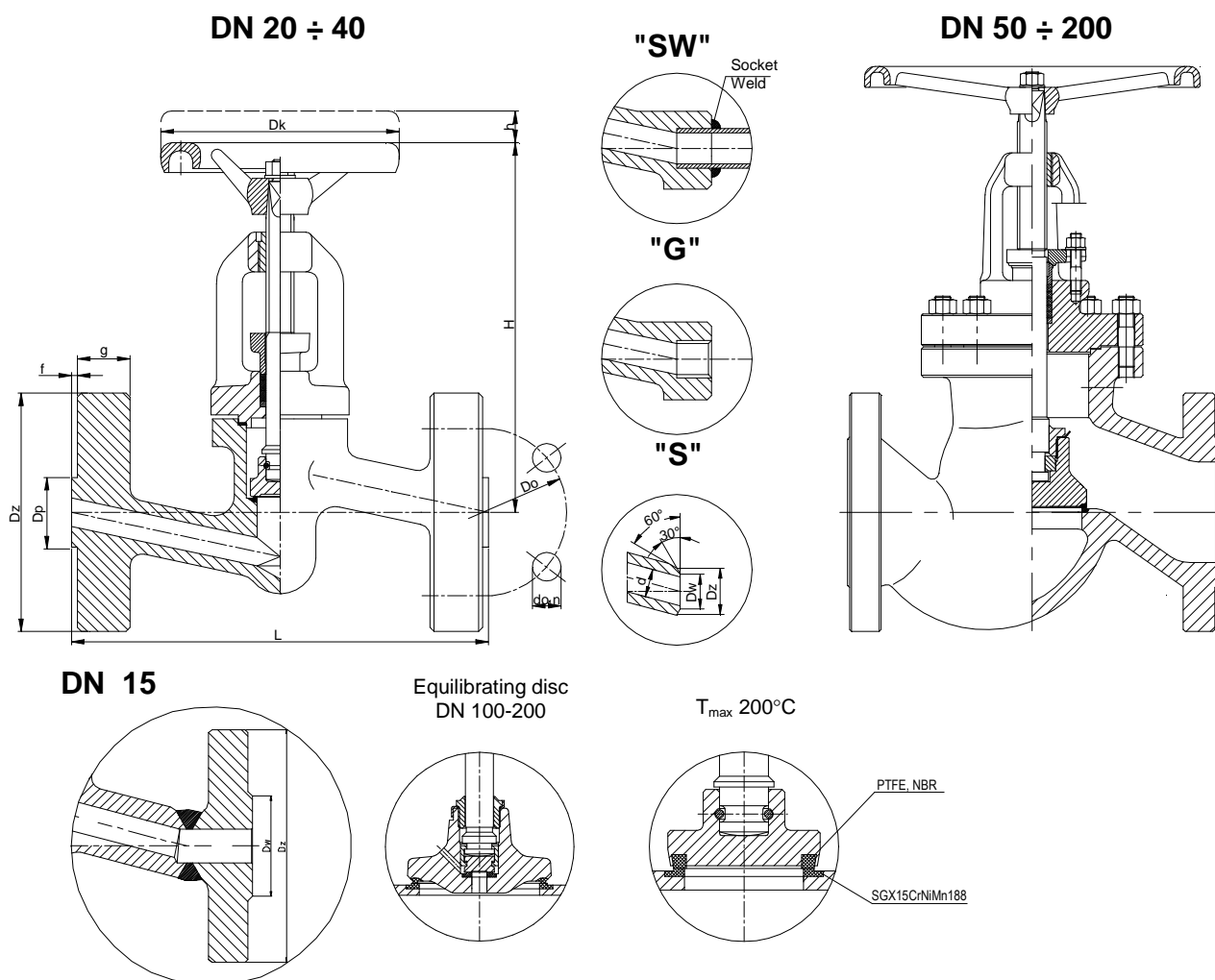

WK



FABRYKA ARMATURY PRZEMYSŁOWEJ

„WAKMET” spółka jawna

Kaczmarek, Krzywdziński, Wachowski, Wilczyński

Bodzanów 75 48-340 GŁUCHOŁAZY 1

tel. +48(077) 439-40-20, fax +48(077) 439-18-72

e-mail: wakmet@wakmet.com.pl

http: www.wakmet.com.pl

MATERIALS:

Versions	Standard	U	A	Other versions
Parts	T _{MAX} 450°C	T _{MAX} 530°C	T _{MAX} 560°C	-
Body, bonnet DN 15-40	(P250GH) C22.8 (1.0460)	16Mo3 (1.5415)	13CrMo4-5 (1.7335)	(P250GH) C22.8, 16Mo3, 13CrMo4-5
Body, bonnet DN 50-200	T _{MAX} 450°C	T _{MAX} 500°C	T _{MAX} 550°C	GP240GH, G20Mo5, G17CrMo5-5
	GP240GH (1.0619)	G20Mo5 (1.5419)	G17CrMo5-5 (1.7357)	
Seat ring DN15-25	X17CrNi16-2			Stellit
Seat ring	G 18 8 Mn (1.4370)			
Disc DN 15-50	X30Cr13 (1.4028)	X30Cr13 (1.4028)	13CrMo4-5 (1.7335)	X30Cr13, 13CrMo4-5
Disc DN 65-200	P250GH (1.0460)	P250GH (1.0460)	13CrMo4-5 (1.7335)	P250GH, 13CrMo4-5
Disc ring	G 18 8 Mn (1.4370)			Stellit, PTFE, NBR
Stem	X20Cr13 (1.4021)	X17CrNi16-2 (1.4057)	X39CrMo17-1 (1.4122)	BT9
Gasket	Grafit + austenite			
Wheel	Cast iron			

Special materials on request; modifications reserved.

DIMENSIONS:

Standard - flanged														With butt weld ends			
DN	d	Dz	Dp	Do	do	n	L	g.	f	H	h	Dk	Weight	Dz	Dw	L	Weight
15	14	105	45	75	14	4	210	20	2	160	13	120	5,40	22	17	160	3,00
20	19	130	58	90	18	4	230	22	2	160	13	160	9,80	28	22	160	3,00
25	23	140	68	100	18	4	230	24	2	160	13	160	10,80	35	28,5	160	3,00
32	30	155	78	110	22	4	260	24	2	210	16	200	15,00	44	36,5	230	9,30
40	38	170	88	125	22	4	260	28	3	210	18	200	15,70	50	43	230	9,50
50	45	180	102	135	22	4	300	26	3	250	22	250	30,70	62	54	300	19,90
65	62	205	122	160	22	8	340	26	3	290	30	250	46,00	77	69	340	30,90
80	73	215	138	170	22	8	380	28	3	300	40	320	62,00	91	81	380	48,70
100	94	250	162	200	22	8	430	30	3	500	55	360	121,50	117	104	430	95,10
125	120	295	188	240	26	8	500	34	3	600	65	400	168,00	144	130,5	500	137,90
150	144	345	218	280	33	8	550	36	3	700	70	500	251,00	172	156,5	550	201,10
200	195	415	285	345	36	12	650	42	3	900	100	600	290,00	223	204,5	650	215,00

Dimensions in mm; modifications reserved.

TECHNICAL DATA:

Body material	PN	Maximal working pressure at working temperature																
		20°C	100°C	150°C	200°C	250°C	300°C	350°C	400°C	450°C	480°C	500°C	510°C	520°C	530°C	540°C	550°C	560°C
(P250GH)C 22.8 (1.0460)	63	63,0	58,5	55,5	52,5	48,0	43,5	40,5	37,5	20,7	-	-	-	-	-	-	-	-
16Mo3 (1.5415)	63	63,0	63,0	63,0	63,0	61,5	54,0	51,0	48,0	46,5	35,3	27,9	22,8	17,7	14,1	-	-	-
13CrMo4-5 (1.7335)	63	63,0	63,0	63,0	63,0	63,0	62,7	60,0	57,0	54,0	46,2	41,1	34,6	28,2	23,4	18,3	14,7	12,0
GP240GH (1.0619)	63	63,0	49,7	45,6	41,4	37,9	34,3	32,0	30,8	19,7	-	-	-	-	-	-	-	-
G20Mo5 (1.5419)	63	63,0	52,2	48,6	45,0	42,0	39,1	36,7	35,5	34,3	25,8	20,1	-	-	-	-	-	-
G17CrMo5-5 (1.7357)	63	63,0	63,0	63,0	63,0	63,0	63,0	63,0	60,0	43,5	31,9	24,3	21,5	18,8	16,0	13,3	10,5	-

MOUNTING AND OPERATING:

The valve can only be mounted and operated by skilled, properly trained and qualified personnel. Incorrect assembly or operation of the valve may have substantial impact on the entire system such as fluid leakage, reduction in system's function etc.

Before a valve is installed the pipeline must be clean from any mechanical impurities. The compatibility of critical parameters of the flow must be checked with the parameters of the valve. Stop globe valve can be mounted to a pipe-line in any position. The direction of flow should only comply with the arrow marked on the body. The valve should be operated strictly with its assign. In order to provide valve's reliability the following suggestions must be observed:

- medium flowing through the valve is supposed to be clean out of any mechanical impurities;
- the valve must be protected from any mechanical damages during its work;
- nominal parameters marked on the valve must be observed.