

LRGT 16-1, LRGT 17-1

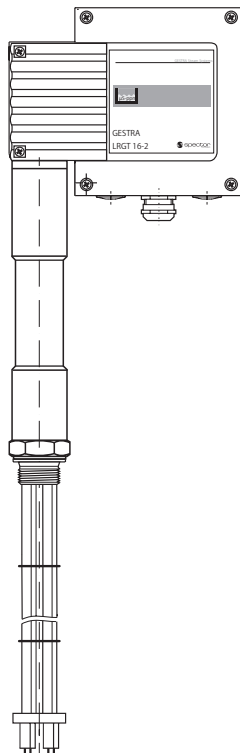

LRGT 16-2



Conductivity Monitoring

LRGT 16-1 LRGT 16-2 LRGT 17-1

Description

The compact-design conductivity transmitter LRGT 16-1, LRGT 16-2, LRGT 17-1 consists of a conductivity electrode, a temperature sensor for detecting the fluid temperature and a conductivity transmitter unit incorporated in the terminal box.

The conductivity transmitters LRGT 16-1 and LRGT 17-1 work according to the conductometric measuring method using two measuring electrodes and the conductivity transmitter LRGT 16-2 works according to the conductometric measuring method using four measuring electrodes. The equipment measures the electrical conductivity of electrically conductive fluids (TDS = Total Dissolved Solids content) and provides a 4-20 mA measuring current as a function of the detected conductivity value.

Conductivity transmitters are used in combination with the following equipment as conductivity limiters and continuous blowdown controllers in steam boilers: **Conductivity controller LRR 1-51, LRR 1-53** and **industrial controller KS 90-1**. Conductivity transmitters can also be used as conductivity monitoring equipment in condensate and feedwater systems.

The conductivity transmitters LRGT 16-1, LRGT 17-1 are mainly used in steam boilers with low TDS content, e.g. steam regenerators, high-pressure boilers or condensate tanks.

The conductivity transmitter LRGT 16-1 is also approved for feedwater monitoring on ships.

The conductivity transmitter LRGT 16-2 is mainly used in industrial boiler plants operating with pressures up to PN 40 and max. admissible conductivities acc. to TRD/EN of 6000 $\mu\text{S}/\text{cm}$.

Function

LRGT 16-1, LRGT 17-1

A measuring current of variable frequency passes through the fluid, creating a potential gradient between the measuring electrode and the reference tube which is then used as measuring voltage U_U .

LRGT 16-2

The conductivity electrode consists of two current and two voltage electrodes. The current electrodes direct the measuring current I_U with a fixed frequency into the fluid, thereby creating a potential gradient between these electrodes. This potential difference is then picked up by the voltage electrodes and evaluated as measuring voltage U_U .

LRGT 16-1, LRGT 17-1 and LRGT 16-2

The electrical conductivity is a function of temperature. A resistance thermometer integrated in the electrode measures the fluid temperatures in order to relate the measured values to the reference temperature.

The electrical conductivity is calculated from the measuring voltages U_U and U_T and – as a function of the adjusted temperature coefficient T_k – linearly based on the reference temperature of 25 °C. Once converted into a conductivity-dependent current signal, an output current of 4 – 20 mA is available for external use.

The cables leading to the measuring electrode, the reference tube and the resistance thermometer are monitored and checked for interruptions and short circuits. In addition, the circuit board is protected against excess temperatures in the terminal box. In the event of a malfunction, the LEDs will light up or flash and the current signal is set to 0 or 0.5 mA.

Function - continued -

The code switch enables the parameterisation of the transmitter, the adaptation of the cell constant and the activation of a performance test. The electrical conductivity is measured in $\mu\text{S}/\text{cm}$. In some countries ppm (parts per million) is used instead. 1 $\mu\text{S}/\text{cm}$ = 0.5 ppm.

Directives and standards

Pressure Equipment Directive 2014/68/EU

The conductivity control & monitoring equipment LRGT 1... .., LRR 1-5... .., KS 90-1 meets the safety requirements of the Pressure Equipment Directive (PED). The conductivity control & monitoring equipment is EC type approved according to EN 12952/EN 12953. These Directives state, among other things, the requirements made on limiting systems and equipment for steam boiler plants and (pressurised) hot-water installations.

VdTÜV Bulletin "Water Monitoring 100"

The conductivity transmitters LRGT 16-1, LRGT 16-2, LRGT 17-1 in conjunction with level controllers LRR 1-51, LRR 1-53 and industrial controller KS 90-1 are type approved according to the VdTÜV Bulletin "Water Monitoring 100".

The VdTÜV Bulletin "Water Monitoring 100" specifies the requirements made on water monitoring equipment.

Approvals for Marine Applications

The conductivity transmitter LRGT 16-1 is approved for marine applications.

LV (Low Voltage) Directive and EMC (Electromagnetic Compatibility)

The conductivity transmitter LRGT 16-1, LRGT 16-2, LRGT 17-1 meets the requirements of the Low Voltage Directive 2014/35/EU and the EMC Directive 2014/30/EU.

ATEX (Atmosphère Explosible)

According to the European Directive 2014/34/EU the equipment must not be used in potentially explosive areas.

UL/cUL (GSA) Approval

The equipment meets the requirements of the following standards: UL 508 and CSA C22.2 No. 14-13, Standards for Industrial Control Equipment. File E243189.

Technical data

Service pressure

LRGT 16-1, LRGT 16-2: 32 bar at 238 °C

LRGT 17-1: 60 barg at 275 °C

End connection

Screwed 1" A, ISO 228

Materials

Screw-in body: 1.4571,

X6CrNiMoTi 17-12-2

Measuring electrode(s): 1.4571, X6CrNiMoTi 17-12-2

Electrode insulation: PTFE

Terminal box: 3.2161 G AISi8Cu3

LRGT 16-1, LRGT 17-1: measuring tube/screw: 1.4571,

X6CrNiMoTi 17-12-2

LRGT 16-1, LRGT 16-2: Spacer disks PTFE/PEEK

LRGT 17-1: Spacer disks PEEK HT

Measuring length & length of installation (electrode cannot be shortened)

LRGT 16-1, LRGT 17-1: 200, 300, 400, 500, 600, 800,

1000 mm (max. 400 mm for marine applications)

LRGT 16-2: 180, 300, 380, 500, 600, 800, 1000 mm

Temperature sensor

Resistance thermometer Pt 1000

Conductivity Monitoring

LRGT 16-1

LRGT 16-2

LRGT 17-1

Technical data - continued -

Electronic module

Supply voltage

24 V DC +/- 20%

Power consumption

4.5 W

Fuse

Electronic thermal fuse $T_{max} = 85\text{ }^{\circ}\text{C}$,

Hysteresis – 2 K.

Measuring cycle

1 sec.

Temperature compensation

Linear, Tk adjustable via code switch

■ 0 % per $^{\circ}\text{C}$,

■ 1.6 – 3.0 % per $^{\circ}\text{C}$ in increments of 0.1

Time constant T

(measured according to two-bath process)

Temperature: 9 sec., conductivity: 14 sec.

Indicators and adjusters

2 LEDs for status messages

1 ten-pole code switch for parameter settings

Measuring range

Temperature coefficient

Cell constant

Performance test

Electrical connection

EMC cable gland with integrated cable gland

M 20 x 1.5

Five-pole screw-type terminal strip, detachable,

conductor size 1.5 mm²

Adjustable measuring ranges *) ($\mu\text{S}/\text{cm}$ at 25 $^{\circ}\text{C}$)

LRGT 16-1, LRGT 17-1	LRGT 16-2
0.5 to 20	100 to 3000
0.5 to 100	100 to 5000
0.5 to 200	100 to 7000
0.5 to 500	100 to 10000
Preferred measuring ranges	
0.5 to 1000	
0.5 to 2000	
0.5 to 6000	
0.5 to 12000	
*) Conversion $\mu\text{S}/\text{cm}$ in ppm (parts per million): 1 $\mu\text{S}/\text{cm} = 0.5\text{ ppm}$	

Current output

4 - 20 mA, proportional to conductivity

Protection

IP 65 to DIN EN 60529

Admissible ambient temperature

Max. 70 $^{\circ}\text{C}$

Storage and transport temperature

-40 up to +80 $^{\circ}\text{C}$

Weight

Approx. 2.5 kg

Approvals:

TÜV approval acc. to VdÜV Bulletin "Water Monitoring 100": Requirements made on water monitoring equipment Type approval no. TÜV · WÜL · XX-003, XX-017.

On board of seagoing vessels LRGT 16-1: GL 33254-06 HH

Dimensions

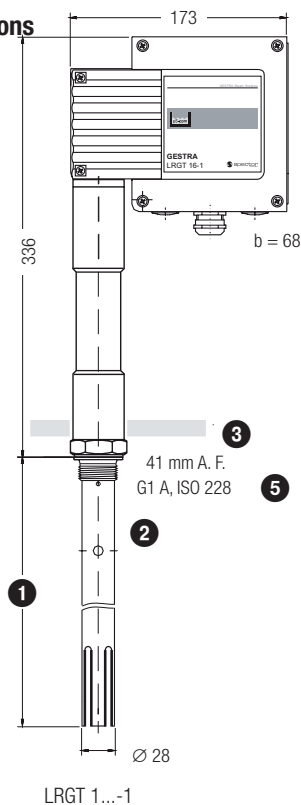

LRGT 1...-1

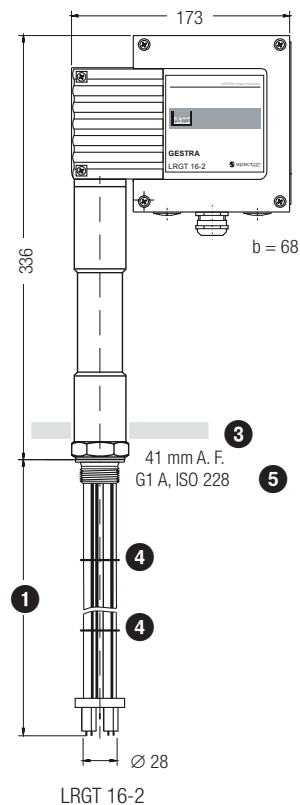

LRGT 16-2

Electrical connection

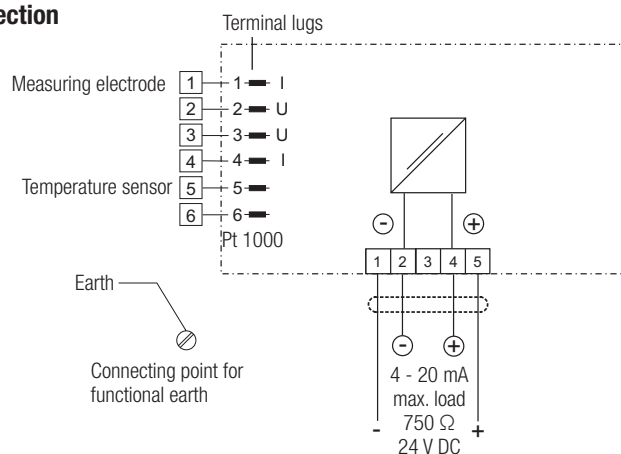

Important Notes

Installation

■ The conductivity transmitter is designed for horizontal or inclined installation. Observe the indicated distances between the lower end of the measuring tube / the measuring electrodes, the boiler wall, the smoke tubes and any other metal fittings as well as the low water level (LW). Note that the measuring surface(s) must be constantly in contact with the water.

■ The measuring tube and the measuring electrodes cannot be shortened.

Electrical connection

■ To supply the conductivity transmitter with 24 V DC, a safety power supply unit (PSU), e.g. Siemens SITOP PSU100C 24V/0.6A, must be used; this must provide a level of isolation against voltages that at least meets the requirements for double or reinforced insulation as per DIN EN 50178 or DIN EN 61010-1 or DIN EN 60730-1 or DIN EN 60950 (electrically protective separation). The PSU must be equipped with a protective device to DIN EN 61010-1.

■ To connect the equipment use screened multi-core control cable with a min. conductor size 0.5 mm², e.g. LiYCY 4 x 0.5 mm², max. length: 100 m.

■ Make sure that connecting cables leading to the equipment are segregated and run separately from power cables.

Key

- 1 Measuring length and length of installation
- 2 Measuring tube
- 3 Thermal insulation, provided on site, d = 20 mm (outside of thermal insulation of steam boiler)
- 4 Spacer disc (only LRGT 16-2 from 800 mm onwards)

Conductivity Monitoring

LRGT 16-1

LRGT 16-2

LRGT 17-1

Order & Enquiry Specification

GESTRA Conductivity Transmitter LRGT 16-1
PN 40, screwed 1"

Two-electrodes measuring system
Measuring range: 0.5 – 10,000 µS/cm
Actual value output: 4 – 20 mA
Measuring length / length of installationmm

GESTRA Conductivity Transmitter LRGT 17-1
PN 63, screwed 1"

Two-electrodes measuring system
Measuring range: 0.5 – 10,000 µS/cm
Actual value output: 4 – 20 mA
Measuring length / length of installationmm

GESTRA Conductivity Transmitter LRGT 16-2
PN 40, screwed 1"

Four-electrodes measuring system
Measuring range: 100 – 10,000 µS/cm
Actual value output: 4 – 20 mA
Measuring length / length of installationmm

Associated Controller and PSU

- Conductivity controller LRR 1-51
- Conductivity controller LRR 1-53
- Industrial Controller KS 90-1
- Power supply unit SITOP PSU100C 24V/0,6A

Key

- 5 Boiler drum
- 6 Joint ring 33 x 39 form D to DIN 7603, made of 1.4301, bright annealed
- 7 T-type connector, provided on boiler DN 50
- 8 Shut-off valve GAV
- 9 Continuous blowdown valve BAE
- 10 Level pot

Examples of installation

Conductivity monitoring, direct installation of the conductivity transmitter via flanged standpipe on side of boiler.

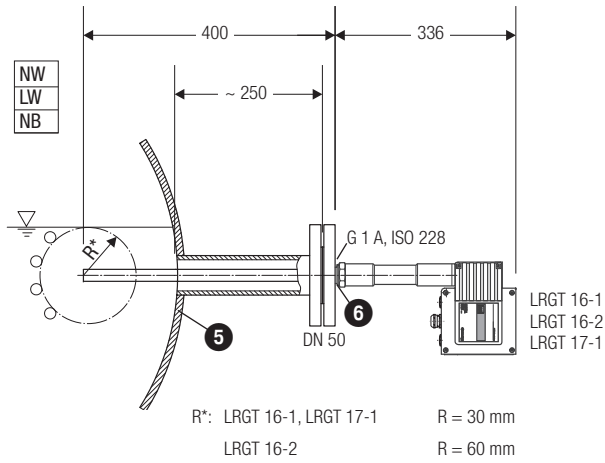

Fig. 1

Conductivity monitoring and continuous boiler blowdown, direct installation of conductivity transmitter via connector and connection of a continuous blowdown valve

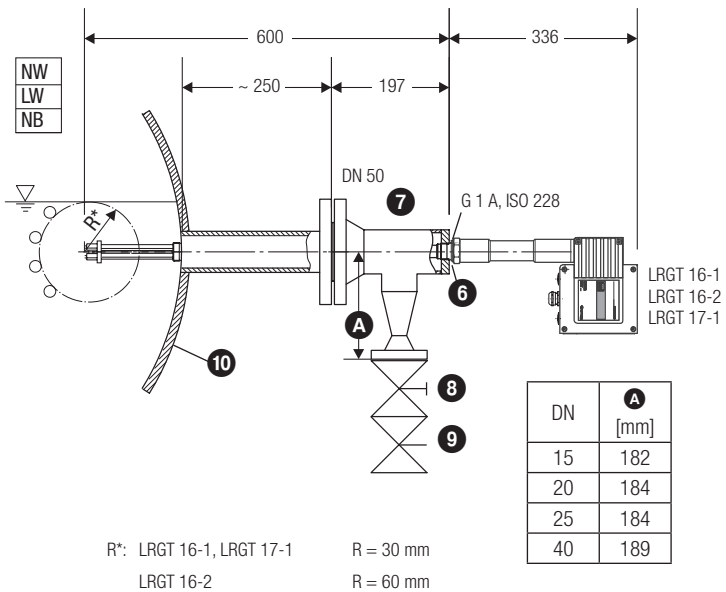

Fig. 2

Conductivity monitoring and continuous boiler blowdown, installation of conductivity transmitter in top blowdown line via separate level pot

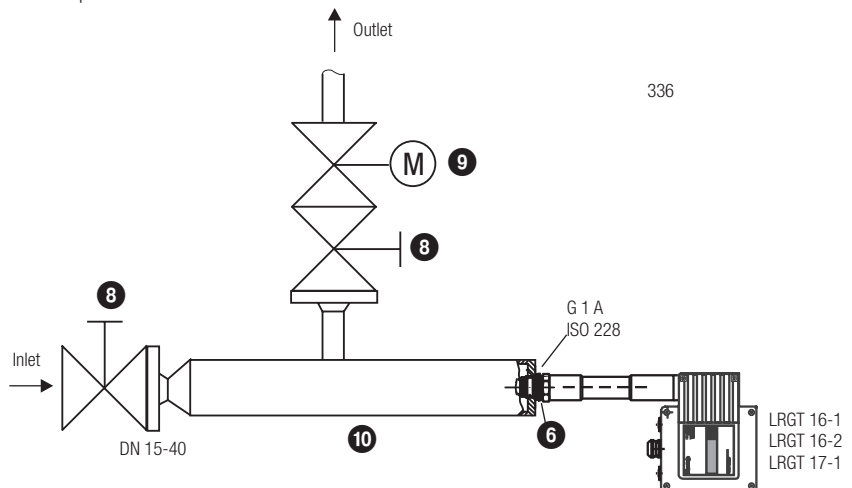

Fig. 3

Supply in accordance with our general terms of business.

Alnab Armatur AB
Ögärdesvägen 4B
SE-433 30 Partille

Tel +46-31 449450
Email alnab@alnab.se
Web www.alnab.se

556312-9716

GESTRA®