

# STOP GLOBE VALVE TYPE 530

## CHARACTERISTIC:

Diameter	-	15 -200 mm;
Pressure	-	160 bar;
Temperature	-	up to 560°C;
Medium	-	water, steam and other non-toxic, non aggressive liquid and gas media and engine fuel.

## VERSIONS:

type / ends / body material / disc and disc ring / drive type

Example: 530 / --- / --- / --- /---

Example: 530 / S / U / L / ---

Ends	Sign	Body material	Sign	Disc and disc ring	Sign	Drive type	Sign
Standard - flanged	---	(P250GH) C 22.8	---	Standard	---	Hand wheel	---
Butt weld ends	<b>S</b>	or GP240GH		STELLIT ring	<b>L</b>	AUMA drive	<b>NA</b>
Socket weld	<b>SW</b>	16Mo3 or G20Mo5	<b>U</b>			NWA drive	<b>NW</b>
Threaded	<b>G</b>	13CrMo4-5 or G17CrMo5-5	<b>A</b>			MODACT drive	<b>NM</b>
						Pneumatic drive	<b>NP</b>

## APPLICATION:

Stop globe valve is designed to open and stop the flow. The valve is not supposed to be used as a regulating device. For regulation the version „R” with throttling plug should be applied.

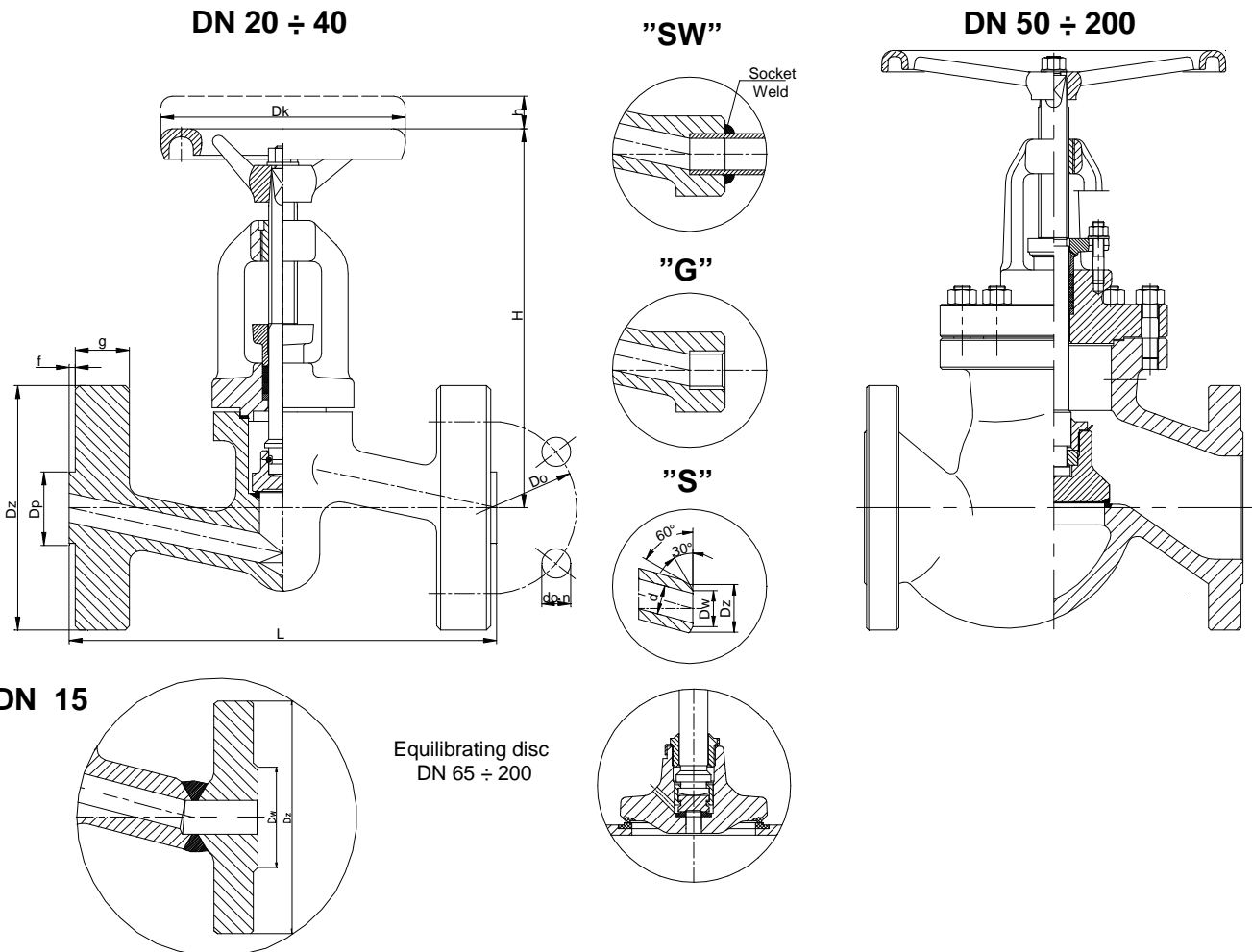

# WK



**FABRYKA ARMATURY PRZEMYSŁOWEJ**

**„WAKMET”** spółka jawna

Kaczmarek, Krzywdziński, Wachowski, Wilczyński  
**Bodzanów 75 48-340 GŁUCHOŁAZY 1**

tel.+48(077) 439-40-20, fax +48(077) 439-18-72

e-mail: wakmet@wakmet.com.pl

http: www.wakmet.com.pl

## MATERIALS:

Versions	Standard	U	A	Other versions
Parts	T <sub>MAX</sub> 450°C	T <sub>MAX</sub> 530°C	T <sub>MAX</sub> 560°C	-
Body, bonnet DN 15-40	(P250GH) C22.8 (1.0460)	16Mo3 (1.5415)	13CrMo4-5 (1.7335)	(P250GH) C22.8, 16Mo3, 13CrMo4-5
Body, bonnet DN 50-200	T <sub>MAX</sub> 450°C GP240GH (1.0619)	T <sub>MAX</sub> 500°C G20Mo5 (1.5419)	T <sub>MAX</sub> 550°C G17CrMo5-5 (1.7357)	GP240GH, G20Mo5, G17CrMo5-5
Seat ring DN15-25	X17CrNi16-2 (1.4057)			Stellit
Seat ring	G 18 8 Mn (1.4370)			
Disc DN 15-50	X30Cr13 (1.4028)	X30Cr13 (1.4028)	13CrMo4-5 (1.7335)	X30Cr13, 13CrMo4-5
Disc DN 65-200	P250GH (1.0460)	P250GH (1.0460)	13CrMo4-5 (1.7335)	P250GH, 13CrMo4-5
Disc ring	G 18 8 Mn (1.4370)			Stellit
Stem	X20Cr13 (1.4021)	X17CrNi16-2 (1.4057)	X39CrMo17-1 (1.4122)	BT9
Gasket	Grafit + austenite			
Wheel	Cast iron			

Special materials on request; modifications reserved.

## DIMENSIONS:

Standard - flanged														With dutt weld ends			
DN	d	Dz	Dp	Do	do	n	L	g.	f	H	h	Dk	Weight	Dz	Dw	L	Weight
15	15	105	45	75	14	4	210	20	2	175	13	120	5,40	22	17	160	3,05
20	20	130	58	90	18	4	230	22	2	215	13	160	9,70	28	21	160	3,05
25	24	140	68	100	18	4	230	24	2	215	13	160	10,60	35	27	160	3,10
32	30	155	78	110	22	4	260	24	2	245	16	200	15,60	44	34,5	230	9,40
40	38	170	88	125	22	4	260	28	3	245	18	200	17,30	50	43	230	9,90
50	47	195	102	145	30	4	300	30	3	300	22	250	29,00	62	52,5	300	20,90
65	63	220	122	170	26	8	340	34	3	330	30	280	47,80	77	65	340	20,90
80	78	230	138	180	26	8	380	36	3	375	40	360	62,00	91	76,5	380	23,00
100	95	265	162	210	30	8	430	40	3	520	55	360	112,00	117	98,5	430	55,00
125	120	315	188	250	33	8	500	44	3	600	65	400	165,00	144	120,5	500	70,00
150	145	355	218	290	33	12	550	44	3	700	70	500	251,00	172	144,5	550	174,00
200	195	430	285	360	36	12	650	60	3	900	110	600	295,00	223	189	650	220,00

Dimensions in mm; modifications reserved.

## TECHNICAL DATA:

Body material	PN	Maximal working pressure at working temperature																
		20°C	100°C	150°C	200°C	250°C	300°C	350°C	400°C	450°C	480°C	500°C	510°C	520°C	530°C	540°C	550°C	560°C
(P250GH)C 22.8 (1.0460)	160	160,0	160,0	160,0	144,8	129,5	114,3	99,1	83,8	52,5	-	-	-	-	-	-	-	-
16Mo3 (1.5415)	160	160,0	160,0	160,0	160,0	156,1	137,1	129,5	121,9	118,0	89,7	70,8	57,8	44,9	35,8			
13CrMo4-5 (1.7335)	160	160,0	160,0	160,0	160,0	160,0	159,2	152,3	144,7	137,1	117,4	104,3	87,9	71,6	59,4	46,4	37,3	30,4
GP240GH (1.0619)	160	160,0	126,3	115,8	105,3	96,2	87,2	81,3	78,2	49,9	-	-	-	-	-	-	-	-
G20Mo5 (1.5419)	160	160,0	132,7	123,4	114,3	106,7	99,2	93,3	90,2	87,2	65,5	51,1	-	-	-	-	-	-
G17CrMo5-5 (1.7357)	160	160,0	160,0	160,0	160,0	160,0	160,0	160,0	152,3	110,5	84,1	61,7	54,7	47,7	40,7	33,7	26,7	-

## MOUNTING AND OPERATING:

*The valve can only be mounted and operated by skilled, properly trained and qualified personnel. Incorrect assembly or operation of the valve may have substantial impact on the entire system such as fluid leakage, reduction in system's function etc.*

Before a valve is installed the pipeline must be clean from any mechanical impurities. The compatibility of critical parameters of the flow must be checked with the parameters of the valve. Stop globe valve can be mounted to a pipe-line in any position. The direction of flow should only comply with the arrow marked on the body. The valve should be operated strictly with its assign. In order to provide valve's reliability the following suggestions must be observed:

- medium flowing through the valve is supposed to be clean out of any mechanical impurities;
- the valve must be protected from any mechanical damages during its work;
- nominal parameters marked on the valve must be observed.