

GasEye Cross Duct HCHO - *in-situ* formaldehyde vapor analyzer



GasEye HCHO is the world's first *in-situ* formaldehyde vapor analyzer. Suitable for emission monitoring and process control. 24/7 continuous operation. No sample preparation. No zero drift. No field calibration. Low cost of ownership.

Features

- HCHO ranges **0-10 ppmv / 0-100 ppmv**
- Process temperature **0-650 °C**
- **Real time sensing** – response time below 0.1 second
- **High selectivity** – no interference from other constituents in the gas sample
- **High sensitivity** – detection limit below 10 ppb per meter
- ***In-situ* monitoring** – reliable and representative formaldehyde measurements in large spaces (e.g. wood-based panel production)
- **Maintenance free** – equipped with a self-calibrating feature, no field calibration necessary
- **Robustness** – IP65 enclosure, suitable for outdoor and indoor installations and harsh environments
- **Insensitive to dust and smoke** in the measured process (up to 50 g/m³)
- **ATEX** version available

Example Applications

- Wood-based panel production
- Coating and varnishing
- Engineered wood products
- Medical - Veterinary
- Coffee roasting
- Painting and corrosion resistant finishes
- Carpet manufacture & storage
- Adhesives
- Heat treatment operations
- Trailer mobile home inspecting
- Automotive emissions

Application type: Formaldehyde CD 51.01.01_AAA

Analytical performance

Formaldehyde concentration measurement ranges: 0 – 10 ppmv /0-100 ppmv

Detection limit: 0.01 ppm*m @STP and 3 sec response time

Precision: 0.01 ppm*m or 1% of the measured value, whichever is larger @STP and 3 sec response time

Accuracy: 0.01 ppm*m or 2% of the measured value, whichever is larger @STP and 3 sec response time

Process dust load: up to 50 g/Nm³ depending on the process

Calibration: NIST traceable factory calibration

Zero drift and span drift: negligible

Electric characteristics

Power input: 24 VDC nominal (19 - 30 VDC)

Power consumption: < 15VA

Dynamic performance

Warm-up time: approx. 5 minutes

Minimum response time (T90): 100 milliseconds

Electric inputs and outputs

Inputs:

4 x analog input, (4-20 mA, process temperature and pressure) - easy user selection via DIP switch between active/passive mode

1 x RTD

8 x digital input

Outputs:

4 x analog output, (4-20 mA, HCHO concentration, process transmission, 2 x AUX) - easy user selection via DIP switch between active/passive mode

8 x digital output (NAMUR)

Optional:

PROFINET, Modbus (TCP/IP), Modbus RTU

Local User Interface:

1. Local user interface (LUI) – LCD backlight display located on the transmitter housing lid

2. Ethernet:

- WebServer application – system configuration and data acquisition via web browser
- Windows based program – GasEye logger for real time data acquisition

Remote access:

Ethernet port for remote service and diagnostics

Mechanical specification

Degree of protection: In accordance with IP65

Process flange: DN50

Process windows: Sapphire window, Helium leak tested and certified in accordance to EN1779:1999 norm.

Instrument dimensions:

Transmitter: Width x height: 330 mm x 230 mm
Length: 350 mm

Receiver: Width x height: 160 mm x 160 mm
Length: 330 mm

Weight: Receiver unit: 15 kg
Transmitter unit: 13 kg

Materials: Housing: aluminium
Coating: RAL 5017
Process interface: Stainless steel 316

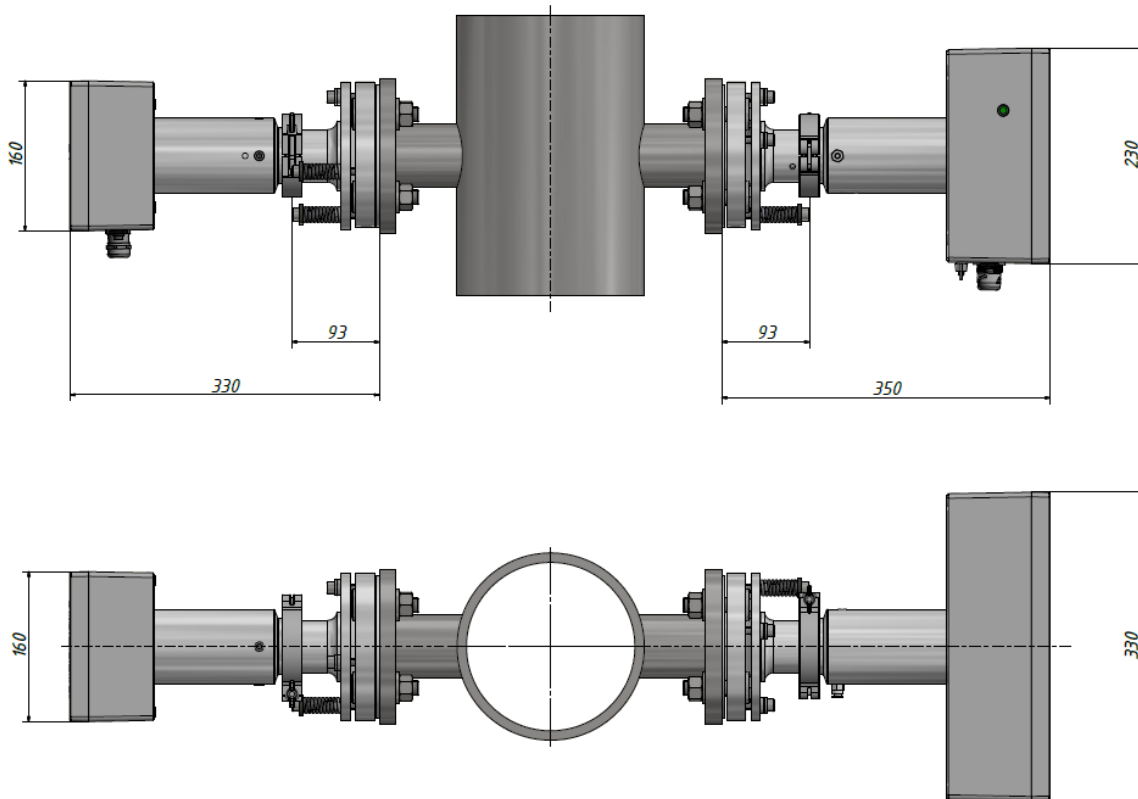

Climatic conditions

Ambient temperature:	-20°C to +55°C
Ambient pressure:	800 - 1200 hPa
Ambient humidity:	RH < 99%, non-condensing

Measurement conditions

Sample gas pressure:	0.9 - 1.1 atm
Sample gas temperature:	0°C to 250°C

Process Purging (if necessary)

Purging gas flow rate:	5 – 10 l/min
------------------------	--------------

Safety

Low Voltage Directive (LVD) 2014/35/EU



- PN-EN 61010-1:2011
- Laser radiation: Laser Class I product acc. to PN-EN 60825-1:2014-11

EMC Directive 2014/30/EU

- EN 61326-1:2013

RoHS Directive 2011/65/EU

ATEX Directive 2014/34/EU

- Explosion protection (standard version):
 - ATEX II 3G [Ex op is IIC T6 Gc]
 - ATEX II 3D [Ex op is IIIC T85°C Dc]
- Explosion protection (optional version):
 - ATEX II 3G Ex pz op is IIC T6 Gc
 - ATEX II 3D Ex pz op is IIIC T85°C Dc

Direct Sales Office:

Airoptic Sp. z o.o.

Ul. Rubiez 46 B, 61-612 Poznan, Poland

sales@airoptic.pl

www.airoptic.pl

tel. +48 61 6272 128