

CHECK VALVE TYPE 564

CHARACTERISTIC:

Diameter	-	15 -200 mm;
Pressure	-	160 bar;
Temperature	-	up to 560°C;
Medium	-	water, steam and other non-toxic, non aggressive liquid and gas media and engine fuel.

VERSIONS:

type / ends / body material / disc and disc ring / others

Example: 564 / --- / --- / --- / ---

Example: 564 / S / U / --- / ---

Ends	Sign	Body material	Sign	Disc and disc ring	Sign	Others	Sign
Standard – flanged	---	(P250GH) C 22.8 or GP240GH	---	Standard	---	-----	---
Butt weld ends	S			STELLIT ring	L		
Socket weld	SW	16Mo3 or G20Mo5	U				
Threaded	G	13CrMo4-5 or G17CrMo5-5	A				

APPLICATION:

The check valve is designed to keep pipeline safe from returning the medium.

DN 20 ÷ 40

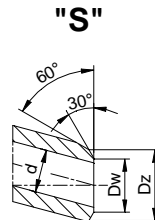
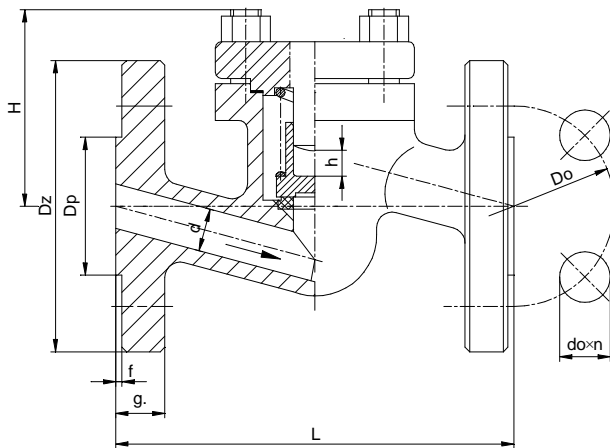

DN 50 ÷ 200

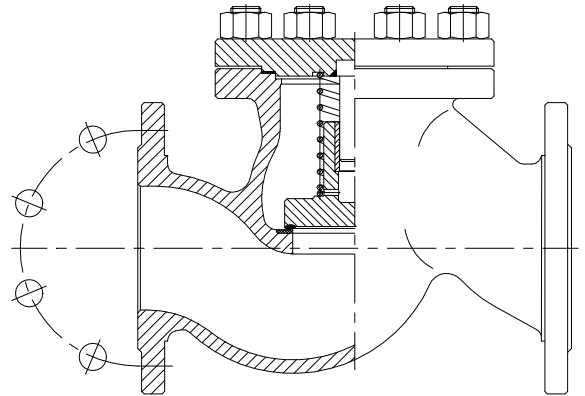

DN 15

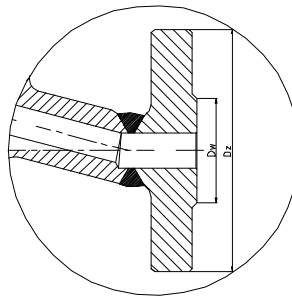

"G"

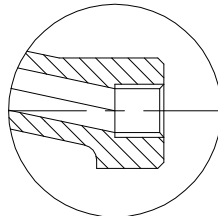

"SW"

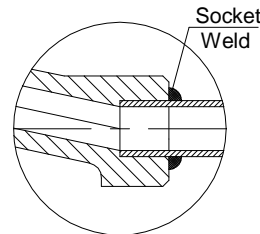

WK



FABRYKA ARMATURY PRZEMYSŁOWEJ

„WAKMET” spółka jawna

Kaczmarek, Krzywdziński, Wachowski, Wilczyński

Bodzanów 75 48-340 GŁUCHOŁAZY 1

tel. +48(077) 439-40-20, fax +48(077) 439-18-72

e-mail: wakmet@wakmet.com.pl

http: www.wakmet.com.pl

MATERIALS:

Versions	Standard	U	A	Standard	U	A
Parts	T _{MAX} 450°C	T _{MAX} 530°C	T _{MAX} 560°C	T _{MAX} 450°C	T _{MAX} 500°C	T _{MAX} 550°C
	DN 15 - 40			DN 50 - 200		
Body, bonnet	(P250GH) C22.8 (1.0460)	16Mo3 (1.5415)	13CrMo4-5 (1.7335)	GP240GH (1.0619)	G20Mo5 (1.5419)	G17CrMo5-5 (1.7357)
Seat ring DN15-25	X17CrNi16-2 (1.4057)					
Seat ring , disc ring	G 18 8 Mn (1.4370) or Stellite					
Disc	X30Cr13 (1.4028) , X17CrNi16-2 (1.4057) , P245GH (1.0352) , 13CrMo4-5 (1.7335)					
Spring	51CrV4 (1.2241)					
Gasket	Grafit + austenite					

Special materials on request; modifications reserved.

DIMENSIONS:

Standard - flanged													Butt weld ends „S”			
DN	d	Dz	Dp	Do	do	n	L	g.	f	H	h	Weight	Dz	Dw	L	Weight
15	14	105	45	75	14	4	210	20	2	70	13	4,00	22	17	160	2,70
20	19	130	58	90	18	4	230	22	2	75	13	6,20	28	21	160	2,70
25	23	140	68	100	18	4	230	24	2	75	13	8,30	35	27	160	2,70
32	30	155	78	110	22	4	260	24	2	95	16	11,50	44	34,5	230	5,20
40	38	170	88	125	22	4	260	28	3	95	18	14,80	50	43	230	7,70
50	45	195	102	145	26	4	300	30	3	140	22	15,70	62	52,5	300	12,90
65	62	220	122	170	26	8	340	34	3	170	30	37,50	77	65	340	26,30
80	73	230	138	180	26	8	380	36	3	195	40	40,30	91	76,5	380	27,50
100	94	265	162	210	30	8	430	40	3	200	55	54,00	117	98,5	430	37,20
125	120	315	188	250	33	8	500	44	3	225	95	76,00	144	120,5	500	48,90
150	144	355	218	290	33	12	550	50	3	300	100	151,00	172	144,5	550	101,10
200	195	430	285	360	36	12	650	6-0	3	400	110	210,00	223	189	650	145,00

Dimensions in mm; modifications reserved.

TECHNICAL DATA:

Body material	PN	Maximal working pressure at working temperature																
		20°C	100°C	150°C	200°C	250°C	300°C	350°C	400°C	450°C	480°C	500°C	510°C	520°C	530°C	540°C	550°C	560°C
		bar																
(P250GH)C 22.8 (1.0460)	160	160,0	160,0	160,0	144,8	129,5	114,3	99,1	83,8	52,5	-	-	-	-	-	-	-	-
16Mo3 (1.5415)	160	160,0	160,0	160,0	160,0	156,1	137,1	129,5	121,9	118,0	89,7	70,8	57,8	44,9	35,8			
13CrMo4-5 (1.7335)	160	160,0	160,0	160,0	160,0	160,0	159,2	152,3	144,7	137,1	117,4	104,3	87,9	71,6	59,4	46,4	37,3	30,4
GP240GH (1.0619)	160	160,0	126,3	115,8	105,3	96,2	87,2	81,3	78,2	49,9	-	-	-	-	-	-	-	-
G20Mo5 (1.5419)	160	160,0	132,7	123,4	114,3	106,7	99,2	93,3	90,2	87,2	65,5	51,1	-	-	-	-	-	-
G17CrMo5-5 (1.7357)	160	160,0	160,0	160,0	160,0	160,0	160,0	160,0	152,3	110,5	84,1	61,7	54,7	47,7	40,7	33,7	26,7	-

MOUNTING AND OPERATING:

The valve can only be mounted and operated by skilled, properly trained and qualified personnel. Incorrect assembly or operation of the valve may have substantial impact on the entire system such as fluid leakage, reduction in system's function etc.

Before a valve is installed the pipeline must be clean from any mechanical impurities. The compatibility of critical parameters of the flow must be checked with the parameters of the valve. Check valve can be mounted to a pipe-line in any position. The direction of flow should only comply with the arrow marked on the body. The valve should be operated strictly with its assign. In order to provide valve's reliability the following suggestions must be observed:

- medium flowing through the valve is supposed to be clean out of any mechanical impurities;
- the valve must be protected from any mechanical damages during its work;
- nominal parameters marked on the valve must be observed.