



brands you trust.

Operating and Maintenance Instructions



Bellows Sealed Globe Valves
Change Over Valves
Molten Salt Valves
Chlorine Valves



Installation, Operation & Maintenance

Bellows Sealed Globe Valves

1. General Instructions

1.1 Important Hints

Contact surfaces of the seat are carefully honed which is necessary to achieve the seat tightness when the valve is closed. Intrusion of foreign materials into the valve during transportation, mounting and operation has to be avoided to protect the sealing system from damages by impurities in spite of its high degree of hardness. The valves are transported and installed in the closed position for this reason.

Attention: Danger of squeezing in seat and stem area!

1.2 Design

Y-type, corner-type and straight-type bellows sealed valves with external or internal stem screw thread 11.3/11.35/11.9
Chlorine bellows sealed globe valves EC11.35
HF Alkylation bellows sealed globe valves HF11.35
3-way change over valves 11.7/11.8
Compact-manifold V 21.9/V21.9 K
Non return valves 14.1/19.1
Overflow valves 14.3/14.35
Strainer 18.1/18.3

1.3 Sizes

Face to face dimensions according EN 558 / EN 12982 or ASME B16.10-2000.

1.4 Application

Depending on material, working pressure, working temperature and medium the valves have to comply with technical standards.

2. Transportation and Storage

Inlets and outlets of the valves are sealed with plastic caps or blank flanges. These have to be removed before installation. Valves must be stored in a clean, tempered and dry room. Condensation inside the valve must be prevented. When storing for a longer period of time, additional corrosion protection of the interior and exterior parts has to be applied.

3. Installation

3.1 General Instruction

In principal bellows sealed valves can be installed in any position, but it is however recommended, not to install bellows sealed valves with the stem upside down in order

to prevent the accumulation of pollution in the bellows area. Before installation please ensure that all pipes and valves are free from impurities which could impair usability. Connecting pipes are to be positioned in such a way, that no undue tensions act onto the valve body.

3.2 Flange Fittings

The sealing surfaces of flange valves have to be clean and without any damages. Bolts are to be tightened cross-wise, gradually and equally along the whole circumference.

3.3 Welded Fittings

Before welding, the welding surfaces of valves and pipes have to be cleaned carefully and any corrosion has to be removed. When welding, cleanliness is an absolute must to ensure that no impurities enter the interior of the valve, which could lead to damaging of the sealing surfaces or bellows. Check if dimensions of welding surfaces of pipes and valves are compatible. Position and tack correctly. Select the appropriate filler materials and welding processes in accordance with the materials of the bodies. The valves must be closed before welding into the line.

3.4 Information to 14.1/14.3/14.35/18.1/18.3/19.1

14.1: In horizontal pipelines, mounting upright, flow direction against the disc. In vertical pipelines, valve should be mounted with the spring pointing upwards, flow direction from bottom to top.

14.3: Flow direction against the plug!

To adjust the spring range, the handwheel cap has to be removed. After correcting the set pressure, the caps have to be remounted.

14.35: Similar method of adjustment after loosening the fixing nuts.

18.1/18.3: Depending of the grade of pollution the screen must be cleaned. Screen has to be checked continuously.

Type 11.3/11.35/EC11.35/11.7/11.8/11.9/ V21.9/V21.9K/14.1/14.3/14.35/18.1/18.3/19.1

4. Start up operation

After the whole system has been pressurised, bellows sealed valves should be opened fully. This activates the metal back seat which seals the stuffing box and ensures that the valve operate free of vibrations. ON/OFF-valves and change-over-valves should not be used in intermediate position.

Standard grooved gasket with graphite layer:

The bonnet flange connection does not have to be re-tightened after reaching the operating temperature, as the gaskets used to have a high compressive resistance and are shrink resistant. However it is recommended to control bolts and nuts force after some operating time.

Grooved gasket with PTFE-layer or gasket complete PTFE:

PTFE material might shrink after a certain period of time. We recommend to check the bolts and nuts of the bonnet flange system max. 1 month after installation. In addition we recommend to check min. 2 - 3 times per year.

5. Maintenance

All valve parts are designed to be maintenance-free, as the materials used for the mating surfaces have been selected in such a way, that wear is only minimal. To ensure operational reliability, all valves should be operated and checked regularly semi-annual.

Should it become necessary to dismount the bonnet, a new gasket has to be fitted for re-mounting.

If the valve needs to be operated for the first time after several months, the stem thread must be lubricated first. If the working temperature exceeds 200°C, enough lubricant on the stem thread is an absolute necessity.

External bearings of change over valves should be checked min. twice per year and if necessary lubricated to avoid damages caused by corrosion.

6. Repair of Failures

6.1 Repacking of the safety stuffing box in case of defective bellows

If the bellows become damaged, the medium penetrates through the loosely tightened stuffing box. In this case the valve has to be fully opened to activate the back seat and then the stuffing box should be tightened slowly until the leak is repaired. In order to make the valve completely

operational again, it is necessary to replace the defective bellows as fast as possible. When the stuffing box needs to be replaced, the pipe system must be depressurised for safety reasons, as the metal back seat might not be absolute leak tight.

6.2 Defective Seats

WTA bellows sealed valves consist of a conical seat which is capable of absorbing minor damages. It is possible to polish off minor seat defects by operation the valve with some force by hand. If the damage is too extensive and no tightness can be achieved even after opening and closing the valve several times under pressure, the valve insert has to be removed. Damage to the valve disc can be removed by machining or by grinding. If the body seat is damaged, it can be re-finished or, if the damage to the seat is too extensive and re-finishing is impossible, the seat has to be renewed by build-up welding. For reasons of expediency this ought to be carried out at the manufacturer.

6.3 Damage of the bellows

As a matter of principle, the complete valve insert should be exchanged whenever the bellows is defective.

7.0 Valves with pneumatic actuators

Attention: Pretensioned springs! Check special instruction before opening.

8.0 Primer

Primer acc. WTA Standard QV0008. For long term use, all valves made of ferritic material have to be protected by additional applicable anticorrosion top coating.

Ausgabe 07/15 - Subject to change without notice

Installation, Operation & Maintenance

Molten Salt Valves

1. General Instructions

1.1 Important Hints

Contact surfaces of the seat are carefully honed which is how the necessary seat tightness is achieved when the valve is closed. The sealing system can however be damaged by impurities despite the high degree of hardness. Intrusion of foreign materials into the valve during transportation, mounting and operation must be avoided. The valves are transported and installed in the closed position for this reason.

Attention: Danger of squeezing in seat and stem area!

1.2 Design

Straight-type, Y-type and corner-type globe valves with external stem screw thread.

1.3 Sizes

Face to face dimensions according DIN, ANSi & BS.

1.4 Application

Depending on material, working pressure, working temperature and medium the valves have to comply with technical standards. The user is responsible for the correct use of the valve materials regarding the medium, corrosion, fatigue and signs of wear. Recurrent examinations are acc. to the national technical rules. We recommend such examinations once a year, but latest after 5 years of use.

2. Transportation and Storage

Inlets and outlets of the valves are sealed with plastic caps. These have to be removed before installation. Valves must be stored in a clean, tempered and dry room. Condensation inside the valve must be prevented. When storing for a longer period of time, additional corrosion protection of the interior and exterior parts has to be applied.

3. Installation

3.1 General Instruction

In principal globe valves can be installed in any position, but it is however recommended, not to install globe valves with the stem upside down in order to prevent the accumulation of pollution. Before installation please ensure that all pipes and valves are free from impurities which could impair usability. Connecting pipes are to be positioned in such a way, that no undue tensions act onto the valve body.

3.2 Welded Fittings

Before welding, the welding surfaces of valves and pipes must be cleaned carefully and any corrosion must be removed. Check if dimensions of welding surfaces of pipes and valves are compatible. Position and tack correctly. Select the appropriate filler materials and welding processes in accordance with the materials of the bodies. The valves must be closed before welding into the line.

4. Start up operation

After the whole system has been pressurised, globe valves should be opened fully. This activates the metal back seat which seals the stuffing box and ensures that the valve operate free of vibrations.

Valves with regulating plug will be supplied with a stem-nut. If the valve will be used in a position between opening and closing, this stem-nut has to be moved towards the bonnet for reducing of stem-vibrations. The bonnet flange connection does not have to be re-tightened after reaching the operating temperature, as the gaskets used to have a high compressive resistance and are shrink resistant. When using special gaskets acc. users specification, please refer to the instructions of the gasket suppliers.

5. Maintenance

All valve parts are designed to be maintenance-free, as the materials used for the mating surfaces have been selected in such a way, that wear is only minimal. To ensure operational reliability, all valves should be operated and checked regularly semi-annual.

Should it become necessary to dismount the bonnet, a new gasket has to be fitted for re-mounting.

If the valve needs to be operated for the first time after several months, the stem thread must be lubricated first. If the working temperature exceeds 200°C, enough lubricant on the stem thread is an absolute necessity.

6. Repair of Failures

6.1 Repacking of the safety stuffing box

If the packing gets leak, the medium penetrates through stuffing box. In this case the valve has to be fully opened to activate the metal back seat. The stuffing box is then tightened slowly until the leak is repaired. In order to make the valve completely operational again, it is, however, necessary to replace the packing. When the stuffing box needs to be replaced, the pipe system must be depressurised for safety reasons, as the metal back seat might not be absolute leak tight. Only use packings released by the manufacturer.

6.2 Defective Seats

WTA globe valves consist of a conical seat which is capable of absorbing minor damages. It is possible to polish off minor disc defects by operation the valve with some force by hand. If the damage is too extensive and no tightness can be achieved even after opening and closing the valve several times under pressure, the valve insert has to be removed. Damage to the valve disc can be removed by machining or by grinding. If the body seat is damaged, it can be re-finished or, if the damage to the seat is too extensive and re-finishing is impossible, the seat has to be renewed by build-up welding. For reasons of expediency this ought to be carried out at the manufacturer.

7. Installation instructions for molten salt packing QuickSet 9001

7.1 General information

For safety reasons, the piping system should be depressurized before repacking the stuffing box. After removing the old packing material from the packing chamber, ensure that there is no major visible damage or grooves in the shaft.

7.2 Technical data

The uncompressed height of the packing set is $s \times 6 + 3.2$ mm (where s = packing cross-section). The gland follower should then extend approx. 2 mm deep into the stuffing box.

For deeper stuffing boxes, a spacer bushing must be used to compensate the height. If possible, the spacer bushing should be made of the same material as the shaft.

7.3 Packing structure

The packing set consists of the following components:

- A: Low compression graphite ring
- B: High compression graphite adapter ring
- C: High compression, reinforced graphite retaining ring
- D: Metal ring
- E: Pure graphite ring
- F: Gasket ring 1303 FEP

The setup can be gathered from the following drawings:

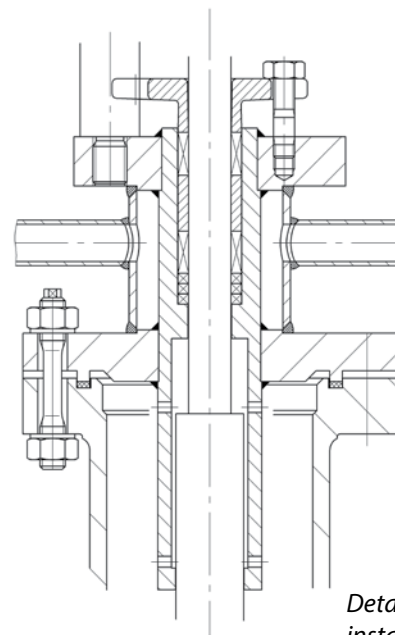

Detailed view: QuickSet installation situation

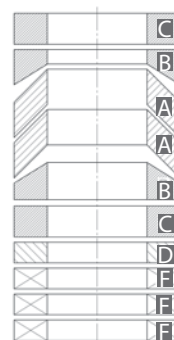

Packing structure for DN 15-65

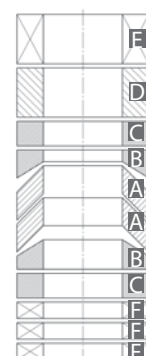

Packing structure for DN 80-200

7.4 Installation

The entire set must be compacted by approx. 20% to a maximum of 25% (packing height). Use a torque wrench to keep track of the fastening torque. After approximately five full stroke cycles, the stuffing box screws should be retightened to the previously determined fastening torque in order to ensure constant gland follower force.

Installation, Operation & Maintenance

BSGV with Pneumatic Diaphragm Actuators

1. Installation

The valves can be operated as automatic valves with pneumatic actuators which can be supplied with emergency operations, air fail spring close or spring open.

Normally, valves are opened by the air control pressure and are closed by a spring as soon as the air flow is interrupted. Valves are to be installed in such a way, that the flow direction of the medium acts against the underside of the disc.

Pneumatic diaphragm actuators are designed for an air pressure upto 6 bar maximum, whereby the built-in pressure spring seals the valve effectively against the differential pressure. The initial pressure is necessary to open the valve completely and the maximum differential pressure vary according to drive capacity and depend upon customer specifications.

2. Regulating Valve Options

Valves are furnished with a long life bellows, which is designed for a service life of 100 000 operations (fully open/close operations at maximum pressure/ temperature ratings). The valve is also fitted with a conical parabolic disc, with either linear or equal percentage flow characteristics.

If specified by the customer, it is possible to install equipment such as pressure reducing valves, filters, solenoid valves, limit switches and positioners. For technical descriptions and operating instructions, please refer to the relevant operating instructions..

3. Installation

Upon request, diaphragm actuators can be fitted with additional manual operation, which acts as an emergency device. This manual adjustment is installed on the outer diaphragm housing and always acts against the spring load. This ensures that, in an emergency, the operation of air regulation pressure can be taken over by the emergency hand wheel.

Chain-Installation Change-Over-Interlocking System Type 11.75 / 11.85

1. On both valves, handwheels to be turned **counterwise**, so that the seats are closed to the stem-side of the valves.

2. Both handwheels are designed as freewheelers for 270 degree of freedom to cover stroke differences from valve 1 to valve 2. Both **chainwheels (1,2)** have to be moved **clockwise** to the end of this degree of freedom.

3. Chain to be cut to the requested dimension first, then to be mounted. **Emergency chain link** is attached to connect the chain. The **emergency chain link** consists of 2 pcs. which have to be mounted together by staking. The **emergency chain link** is **not designed** for permanent usage and loading.

4. To tension the chain, **stud bolt 1** in **nut 2** below the chainwheel has to be loosened. Then loosen **nut 2** to move **chain tightener 3** towards the chain. Afterwards **nut 2** has to be tightened and **stud bolt 1** has to be placed correctly to secure **nut 2** in position.

5. While turning the handwheels to change the position from the valve piston, both handwheels have to be positioned correctly. Please don't work only by turning 1 handwheel. Please check closed and opened position of both valves.

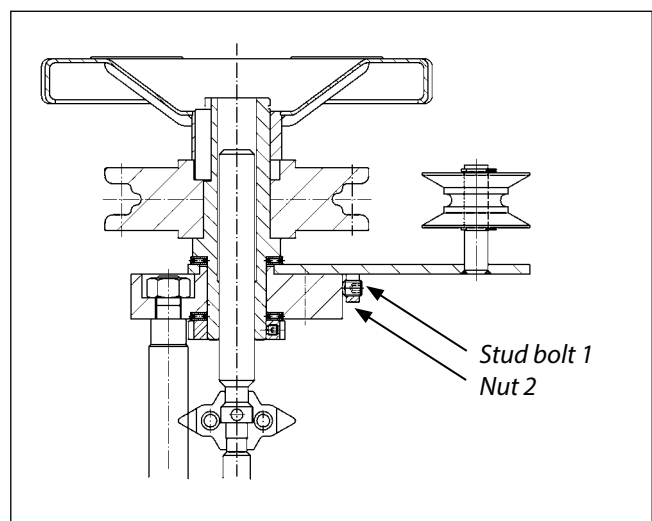
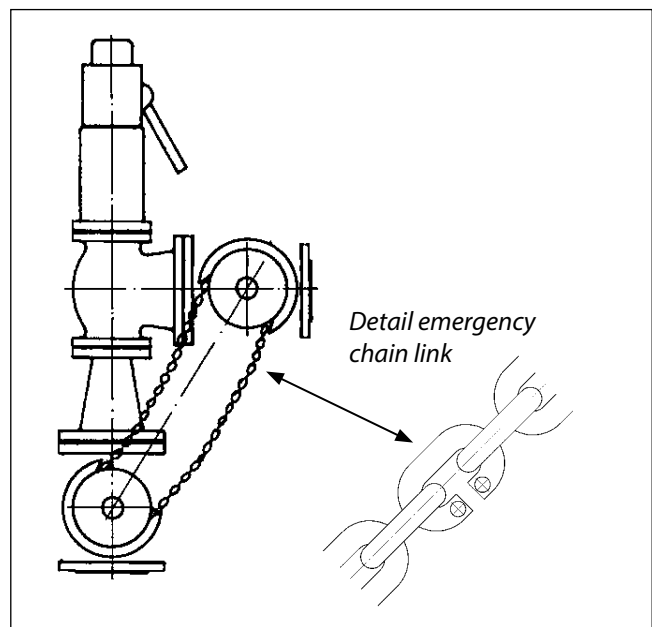
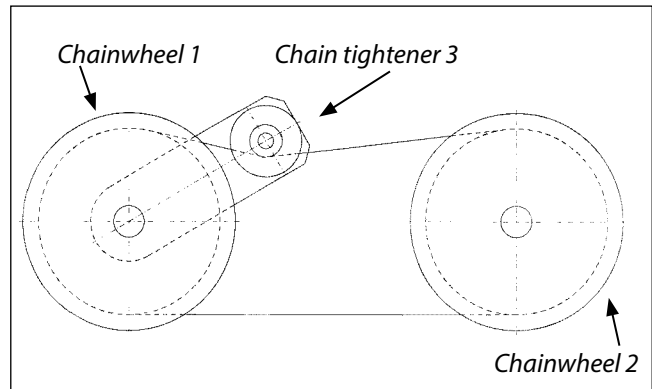



Crane ChemPharma & Energy

Xomox International GmbH & Co. OHG

Von-Behring-Straße 15,

88131 Lindau/Bodensee

Germany

Tel: +49 8382-702-0

Fax: +49 8382-702-114

www.cranecpe.com



brands you trust.



COMPAC-NOZ®



DEPA®

ELRO®

DUO-CHEK®



NOZ-CHEK®



RESISTOFLEX®



STOCKHAM®



UNI-CHEK®

wta.®

XOMOX®

Crane Co., and its subsidiaries cannot accept responsibility for possible errors in catalogues, brochures, other printed materials, and website information. Crane Co. reserves the right to alter its products without notice, including products already on order provided that such alteration can be made without changes being necessary in specifications already agreed. All trademarks in this material are property of the Crane Co. or its subsidiaries. The Crane and Crane brands logotype, in alphabetical order, (ALOYCO®, CENTER LINE®, COMPAC-NOZ®, CRANE®, DEPA®, DUO-CHEK®, ELRO®, FLOWSEAL®, JENKINS®, KROMBACH®, NOZ-CHEK®, PACIFIC VALVES®, RESISTOFLEX®, REVO®, SAUNDERS®, STOCKHAM®, TRIANGLE®, UNI-CHEK®, WTA®, and XOMOX®) are registered trademarks of Crane Co. All rights reserved.