

LRR 1-52, LRR 1-53

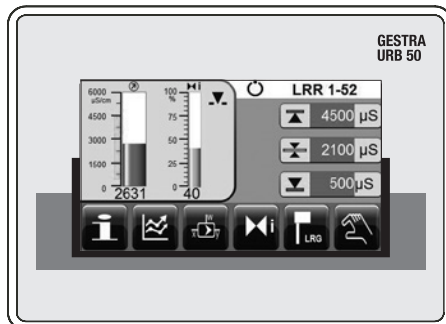

URB 50

Conductivity Controller

LRR 1-52, LRR 1-53

Operating & Display Unit

URB 50

Description

The functional unit consisting of the operating & display unit URB 50 / conductivity controller LRR 1-52, LRR 1-53 in conjunction with conductivity electrodes LRG 1... and conductivity transmitter LRGT 1... is used as conductivity controller and limiter, for instance in steam boilers, (pressurized) hot-water installations as well as condensate and feedwater tanks. The conductivity controller indicates when the preset MAX or MIN conductivity is reached, opens or closes a continuous blowdown valve and may also control an intermittent blowdown valve.

The conductivity controller can be used together with conductivity electrodes and transmitters in the following equipment combinations: Conductivity controller LRR 1-52 together with conductivity electrodes LRG 12-2, LRG 16-4, LRG 16-9, LRG 17-1 and LRG 19-1; Conductivity controller LRR 1-53 together with conductivity transmitters LRGT 16-1, LRGT 16-2, LRGT 16-3, LRGT 16-4, LRGT 17-1 and LRGT 17-3.

Function

The **operating & display unit URB 50** and the **conductivity controller LRR 1-52, LRR 1-53** form a functional unit featuring the following properties:

Conductivity controller	LRR 1-52	LRR 1-53
Conductivity monitoring using conductivity electrode LRG 1... or conductivity electrode LRG 16-9 with integrated resistance thermometer	X	
Evaluation of current signal of conductivity transmitter LRGT 1...		X
3-position stepping controller with proportional-plus-integral control action (PI controller) and control of an electrically actuated continuous blowdown valve	X	X
Indication of MAX conductivity limit (conductivity limiter)	X	X
Indication of MIN conductivity limit or control of intermittent blowdown valve	X	X
Indication of valve position if a potentiometer is incorporated in the continuous blowdown valve	X	X
Actual value output 4-20 mA	X	X
Operating & display unit	URB 50	
Indication of actual value (indicated in percent and as bar graph)	X	
Indication of valve position (indicated in percent and as bar graph)	X	
Setting of measuring range	X	
Indication/adjustment of control parameters and settings	X	
Trend record	X	
Indication and listing of errors, alarms and warnings	X	
Test of MIN / MAX output relays and/or control of intermittent blowdown valve	X	
Manual/automatic operation	X	
Password protection	X	

Directives and standards

Pressure Equipment Directive 2014/68/EU

The conductivity control & monitoring equipment LRG 1..., LRGT 1..., LRR 1-52, LRR 1-53 meets the safety requirements of the Pressure Equipment Directive (PED). The conductivity control & monitoring equipment is EC type approved according to EN 12952/EN 12953. These Directives state, among other things, the requirements made on limiting systems and equipment for steam boiler plants and (pressurised) hotwater installations.

VdTÜV Bulletin "Water Monitoring 100"

The functional unit consisting of the operating & display unit URB 50 / conductivity controller LRR 1-52, LRR 1-53 in conjunction with conductivity electrode LRG 1... and conductivity transmitters LRGT 16-1, LRGT 16-2, LRGT 16-3, LRGT 16-4, LRGT 17-1 and LRGT 17-3 is type approved according to VdTÜV Bulletin "Wasserüberwachung (= Water Monitoring) 100".

Type approval no. TÜV · WÜL · xx-017 (see name plate).

The VdTÜV Bulletin "Water Monitoring 100" states the requirements made on water monitoring equipment.

LV (Low Voltage) Directive and EMC (Electromagnetic Compatibility)

The equipment meets the requirements of the Low Voltage Directive 2014/35/EU and the EMC Directive 2014/30/EU.

ATEX (Atmosphère Explosible)

According to the European Directive 2014/34/EU the equipment must not be used in potentially explosive areas.

UL/cUL (CSA) Approval

The equipment meets the requirements of: UL 508 and CSA C22.2 No. 14-13, Standards for Industrial Control Equipment. File E243189.

Glossary

Continuous boiler blowdown

As the boiler water evaporates, the concentration of non-volatile dissolved solids (TDS) left behind in the boiler increases over time as a function of steam consumption. If the TDS (= total dissolved solids) concentration exceeds the limit defined by the boiler manufacturer, foaming and priming occurs as the density of the boiler water increases, resulting in a carry-over of solids with vapour into steam lines and superheaters.

As a consequence, the operational safety is impaired and severe damage to boiler and tubes may occur. To keep the TDS concentration within admissible limits, a certain portion of boiler water must be removed continuously or periodically (by means of a blowdown valve) and fresh make-up water must be added to the boiler feed to compensate for the water lost through blowdown.

Electrical conductivity - here as a result of the TDS content of boiler water - is measured in microSiemens/cm (µS/cm). However, in some countries ppm (parts per million) is used for conductivity readings. Conversion: 1µS/cm = 0.5 ppm.

Glossary - continued -

Intermittent boiler blowdown

During the evaporation process fine sludge deposits settle on heating surfaces and in the lowest part of the steam boiler. The accumulated sludge sediments form a thermally insulating layer and can damage the boiler walls due to excessive heat. To perform a bottom blowdown the intermittent blowdown valve must be opened abruptly. The resulting suction effect occurs only at the moment when the valve is being opened, the opening time should therefore not exceed 3 seconds. Longer blowdown periods will merely waste boiler water.

Conductivity Controller

LRR 1-52, LRR 1-53

Operating & display unit

URB 50

Glossary - continued -

Intermittent boiler blowdown

The timed pulse/interval control of the intermittent blowdown valve optimises sludge removal while minimising loss of boiler water. The interval between the intermittent blowdown pulses can be set between 1 and 200 h (intermittent blowdown interval T_i). The duration T of the intermittent blowdown can be set between 1 and 10 sec. For larger boilers it may be necessary to repeat the intermittent blowdown pulses. The repetition rate can be set between 1 and 10 with a time interval between 1 - 10 seconds (pulse interval T_p).

External intermittent blowdown

Note that simultaneous intermittent blowdown is not allowed if several steam boilers are connected to one single blowdown receiver / mixing cooler. In this case the external intermittent blowdown control unit PRL 50-4 monitors and controls the individual intermittent blowdown operations.

Temperature compensation

The electrical conductivity changes as the temperature falls or rises. To obtain meaningful readings it is therefore necessary that the measurements are based on the reference temperature of 25 °C and that the measured conductivity values are corrected by the temperature coefficient factor t_C .

Cell constant and correction factor

The cell constant is a geometric quantity characteristic of the conductivity electrode and is taken into account when calculating the conductivity. However, in the course of time this constant may change, e. g. due to dirt deposits accumulated on the measuring electrode. Deviations can be compensated by changing the correction factor CF.

Purging of the continuous blowdown valve

To prevent the continuous blowdown valve from getting stuck the valve can be rinsed automatically. At regular intervals (purging interval T_i) the continuous blowdown valve is motored into the open position and rinsed (purging time S_d). After purging the valves is motored back into the required control position.

Stand-by operation (conductivity control)

To avoid loss of water, the continuous blowdown control and the programme-controller intermittent boiler blowdown (if activated) can be de-activated during stand-by operation or when the burner is switched off. An external control command will be triggered and, as a result, the continuous blowdown valve will be closed. During stand-by operation the MIN/MAX limits and the monitoring function remain active.

After the equipment switches back to normal operation, the continuous blowdown valve is motored back into control position. In addition an intermittent blowdown pulse is triggered off (provided that automatic intermittent boiler blowdown has been activated and an interval period and pulse duration has been set).

Important Notes

The conductivity controller LRR 1-52, LRR 1-53 is clipped onto the support rail in the control cabinet. The operating & display unit URB 50 is installed in the cut-out of the control cabinet.

The conductivity controller as well as the operating unit are supplied with 24 V DC and fused internally (URB) or externally (LRR 1-5..., semi-delay 0.5 A).

The power supply unit must be electrically isolated from dangerous contact voltages and must meet at least the requirements on double or reinforced isolation according to one of the following standards: DIN EN 50178, DIN EN 61010-1, DIN EN 60730-1 or DIN EN 60950.

To prevent the welding together of contacts provide an external slow-blow fuse T 2.5 A or 1.0 A (TRD 604, 72 hrs. operation) for the output contacts.

When switching off inductive loads, voltage spikes are produced that may impair the operation of control systems. Connected inductive loads must be provided with suppressors such as RC combinations as specified by the manufacturer.

To connect the conductivity electrode LRG 12-1, LRG 16-4, LRG 17-1 and LRG 19-1 use screened multi-core control cable with a min. conductor size of 0.5 mm², e. g. LiYCY 3 x 0.5 mm².

For connecting the conductivity electrode LRG 16-9 control cable assemblies of various lengths are available as optional extra.

Note that the recommended control cable is not UV-resistant and, if installed outdoors, must be protected by a UV-resistant plastic tube or cable duct.

If you do not use the above-mentioned control cable assembly, use screened five-core control cable, e. g. LiYCY 5 x 0.5 mm², for connecting the equipment. In addition, connect at the electrode end a screened jack to the control cable.

Max. cable length between conductivity electrode and controller: 30 m, with conductivities from 1 to 10 µS/cm: max. 10 m.

Make sure that connecting cables between the equipment are segregated and run separately from power cables.

When used as conductivity limiter the conductivity controller LRR 1-52, LRR 1-53 does not interlock automatically when the readings exceed the MAX limit.

If an interlock function is required for the installation it must be provided in the follow-up circuitry (safety circuit). The circuitry must meet the requirements of the EN 50156.

Order & Enquiry Specification

Level switch type LRR 1-52

GESTRA SPECTOR^{module} Touch

Continuous conductivity controller with MIN and MAX alarm

Input: 1 input for conductivity electrode

1 input for PT 100 sensor

Output: 1 actual value 4-20mA

2 volt-free change-over contacts for MIN/MAX alarm

2 volt-free change-over contacts for valve control incl.

1 separate operating & display unit type URB 50 with colour touch panel

Supply voltage: 24 V DC, 13 VA

Level switch type LRR 1-53

GESTRA SPECTOR^{module} Touch

Continuous conductivity controller with MIN and MAX alarm

Input: 1 input for conductivity transmitter LRGT (4-20 mA)

Output: 1 actual value 4-20mA

2 volt-free change-over contacts for MIN/MAX alarm

2 volt-free change-over contacts for valve control incl.

1 separate operating & display unit type URB 50 with colour touch panel

Supply voltage: 24 V DC, 13 VA

Technical data

Supply voltage

24 VDC, + / - 20 %

Fuse

external 0.5 A (semi-delay)

Power consumption

5 VA

Reset hysteresis

MAX limit: -3 % of the adjusted MAX limit, fixed setting

Input/output

Interface for data exchange with operating & display unit URB 50

Inputs

1 volt-free input, 24 VDC, for external command "Control OFF", "Valve CLOSED", "Intermittent blowdown OFF" (stand by).

1 analogue input for potentiometer 0 - 1000 Ω, two-wire connection (indication of valve position)

Outputs

2 volt-free change-over contacts, 8 A 250 V AC / 30 V DC $\cos \varphi = 1$ (continuous blowdown valve).

2 volt-free change-over contacts, 8 A 250 V AC / 30 V DC $\cos \varphi = 1$, or

1 volt-free change-over contact, 8 A 250 V AC / 30 V DC $\cos \varphi = 1$,

1 volt-free change-over contact, 8 A 250 V AC / 30 V DC $\cos \varphi = 1$ (intermittent blowdown valve)

Provide inductive loads with RC combinations according to manufacturer's specification to ensure interference suppression.

1 analog output 4-20 mA, max. load 500 ohm (actual value) (optional)

Indicators and adjusters

1 tri-colour LED indicator

(start-up = amber, power ON = green, malfunction = red)

1 code switch with four poles for configuration

Housing

Housing material: base: polycarbonate, black; front: polycarbonate, grey

Conductor size: 1 x 4.0 mm² solid per wire or

1 x 2.5 mm² per stranded wire with sleeve to DIN 46228 or

2 x 1.5 mm² per stranded wire with sleeve to DIN 46228 (min. Ø 0.1 mm)

Terminal strips can be detached.

Fixing of housing: Mounting clip on supporting rail TH 35, EN 60715

Electrical safety

Pollution degree 2 for installation in control cabinet with protection IP 54, completely insulated

Protection

Housing: IP 40 to EN 60529

Terminal strip: IP 20 to EN 60529

Weight

approx. 0.5 kg

Further conditions:

Ambient temperature

when system is switched on: 0 ... 55 °C, during operation: -10 ... 55 °C

Transport temperature

-20 ... +80 °C (< 100 hours), defrosting time of the de-energized equipment before it can be put into operation: 24 hours.

Storage temperature

-20 ... +70 °C, defrosting time of the de-energized equipment before it can be put into operation: 24 hours.

Relative humidity

max. 95%, no moisture condensation

Conductivity Controller

LRR 1-52, LRR 1-53

Technical data

only conductivity controller LRR 1-52

Connection of conductivity electrode
 1 input for conductivity electrode LRG 1-... (cell constant 1 cm-1), 3 poles with screen or 1 input for conductivity electrode LRG 16-9 (cell constant 0.5 cm-1), with integrated resistance thermometer Pt 100, 5 poles with screen

Measuring voltage

0.8 Vss, pulse duty factor $t_v = 0.5$, frequency 20-10000 Hz.

Measuring range

1 to 10,000 $\mu\text{S}/\text{cm}$ at 25 °C or 1 to 5,000 ppm at 25 °C.

only conductivity controller LRR 1-53

Connection of conductivity transmitter
 1 analogue input 4-20 mA, e. g. for conductivity transmitter LRGT 1-... , 2 poles with screen

Beginning of measuring range SinL

0.0 - 0.5 - 100.0 $\mu\text{S}/\text{cm}$, adjustable.

End of measuring range SinH

20.0 - 100.0 - 200.0 - 500.0 - 1000.0 - 2000.0 - 3000, 0 - 5000.0 - 6000.0 - 7000.0 - 10000.0 $\mu\text{S}/\text{cm}$, adjustable.

Key

- 1 Upper terminal strip
- 2 Lower terminal strip
- 3 Housing
- 4 Supporting rail type TH 35, EN 60715
- 5 Connection of supply voltage 24 V DC with fuse 0.5 A (semi-delay) provided on site
- 6 Actual value output 4-20 mA (optional)
- 7 Indication of valve position, potentiometer 0 - 1000 Ω
- 8 Data line for operating & display unit URB 50
- 9 Conductivity electrode LRG 1-... .
- 10 Central earthing point (CEP) in control cabinet
- 11 Conductivity electrode LRG 16-9 with integrated resistance thermometer
- 12 MIN output contact or actuation of intermittent blowdown valve
- 13 Output contact for actuation of continuous blowdown valve
- 14 MAX output contact
- 15 Stand-by input, 24 VDC, for external command "Control OFF", "Valve CLOSED", "Intermittent blowdown OFF"
- 16 Conductivity transmitter LRGT 1-... , 4-20 mA, with earthing point

Dimensions

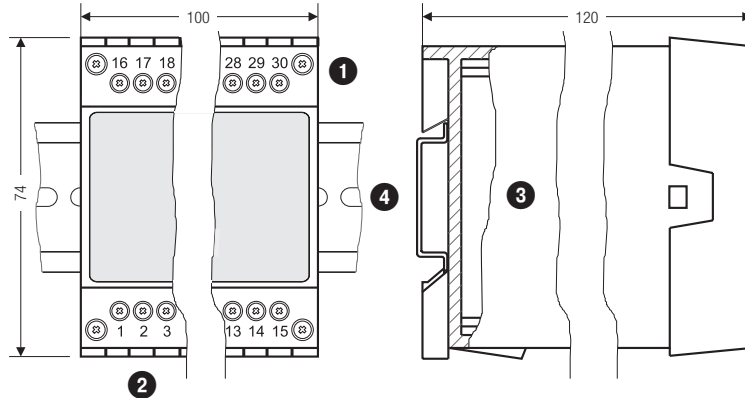

Fig. 1 LRR 1-52, LRR 1-53

Electrical connection LRR 1-52

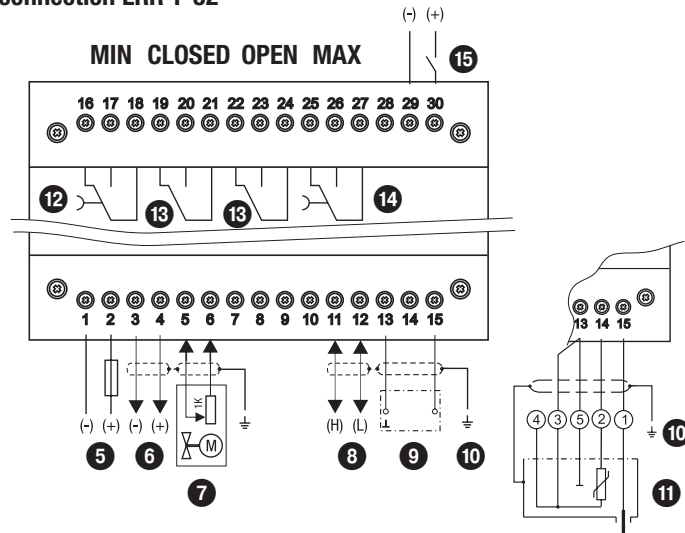

Fig. 2

Electrical connection LRR 1-53

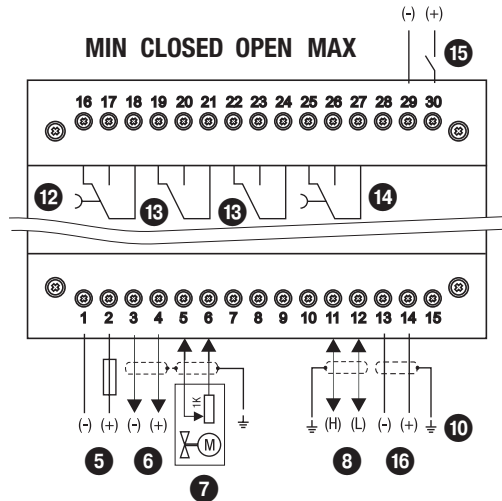

Fig. 3

Operating & display unit URB 50

Technical data

Supply voltage

24 VDC +/- 20%

Fuse

internal automatic

Power consumption

8 VA

Input/output

Interface for data exchange with level controller NRR 2-52, NRR 2-53.

User interface

Analogue resistive touch screen, resolution 480 x 271 pixels, illuminated

Dimensions

Front panel 147 x 107 mm

Panel cut-out 136 x 96 mm

Depth 56 + 4 mm

Electrical connection

1 three-pole connector

1 nine-pole D-SUB connector

Protection

Front: IP 65 to EN 60529

Back: IP 20 to EN 60529

Weight

approx. 1.0 kg

Ambient temperature

when system is switched on: 0 ° ... 55 °C,

during operation: -10 ... 55 °C

Transport temperature

-20 ... +80 °C (<100 hours), defrosting time of the

de-energized equipment before it can be put into

operation: 24 hours.

Storage temperature

-20 ... +70 °C, defrosting time of the de-energized

equipment before it can be put into operation: 24 hours.

Relative humidity

5-85 %, no moisture condensation

Key

18 Control panel cut-out 136x96 mm

19 Seal

20 D-SUB connector with 9 poles for data line

21 Connector with 3 poles for supply voltage connection

24 V DC

22 Connection for supply voltage **24 V DC**, pin assignment

CEP Central earthing point (CEP) in control cabinet

Dimensions

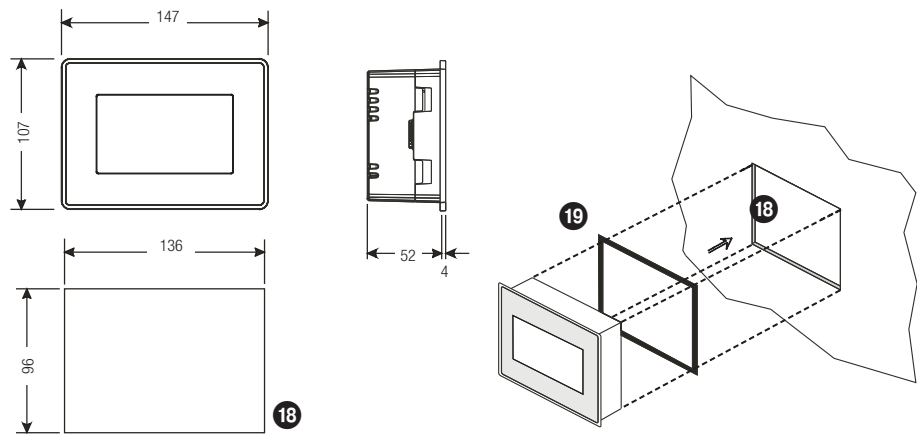
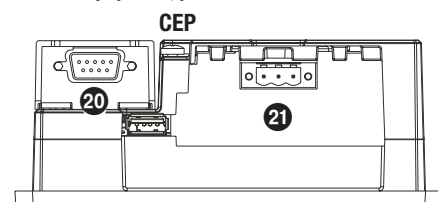

Fig. 4

Electrical connection URB 50

Back of equipment, position of connector



Connection of supply voltage

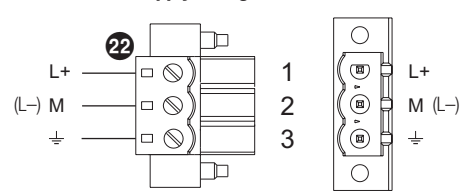

Pin assignment for data line NRR 2-52, NRR 2-53 - URB 50

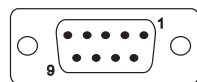

20

PIN 2	Data_L
PIN 7	Data_H

Fig. 5

Supply in accordance with our general terms of business.

Alnab Armatur AB
Ögärdesvägen 4B
SE-433 30 Partille

Tel +46-31 449450
Email alnab@alnab.se
Web www.alnab.se

556312-9716

GESTRA®