

MSB-1, MSB-1.2

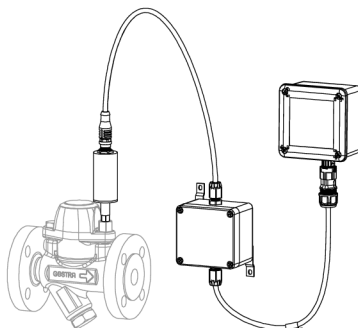

MSB-1 Ex, MSB-1.2 Ex

ecoBolt Continuous Steam Trap Monitor

MSB-1, MSB-1.2

MSB-1 Ex, MSB-1.2 Ex

EN
English

Original Installation Instructions

850910-01

Contents

Foreword	3
Availability.....	3
Formatting features in the document	3
Safety	4
Use for the intended purpose	4
Basic safety notes	4
Information on property damage or malfunctions	5
Qualification of personnel.....	5
Protective gear	5
Typographic features of warning notes.....	6
Formatting features for warnings of property damage	6
Description	6
Scope of supply and equipment specification	6
Task and function	10
Storing and transporting the equipment	11
Storing the equipment	11
Transporting the equipment	11
Mounting and connecting the equipment	11
Preparing installation	11
Mounting the equipment	12
Starting up the equipment.....	16
Operation	17
After operation	17
Switching the equipment off	17
Removing external dirt deposits	18
Maintaining the equipment.....	18
Checking the component parts for damage	18
Servicing the equipment and installing spare parts	18
Troubleshooting	20
Putting the equipment out of operation	22
Removing the equipment	22
Returning the equipment.....	23
Disposing of the equipment.....	23
Technical data	24
Dimensions and weights	24
Electrical data	25
Ambient conditions.....	25
Pressure & temperature ratings	26
Declaration of Conformity – Standards and Directives	27

Foreword

This Installation & Operating Manual will help you ensure the correct, safe and cost-effective use of the following continuous steam trap monitoring equipment:

- ▶ MSB-1, MSB-1.2
- ▶ MSB-1 Ex, MSB-1.2 Ex

This continuous steam trap monitoring equipment is referred to below simply as 'equipment'.

The equipment consists of several assemblies:

- ▶ MSBS ... sensor
- ▶ MSBA ... pre-amplifier
- ▶ MSBN ... LoRa node

This installation & operating manual is intended for anyone commissioning, using, operating, servicing, cleaning or disposing of this equipment and, in particular, for professional after-sales service technicians, qualified personnel and authorised and trained staff.

All of these persons must read and understand the content of this installation & operating manual.

Following the instructions given in this installation & operating manual helps avoiding danger and increases the reliability and service life of the equipment. Please note that in addition to the instructions given in this installation & operating manual you must also observe all locally applicable rules and regulations concerning the prevention of accidents as well as approved safety guidelines for good professional practice.

Please also read and follow the instructions in the MSBN-1/MSBN-1 Ex LoRa node Installation & Operating Manual and, with the MSBN-1 Ex, in the certificate as well.

Availability

Keep this installation & operating manual together with the plant documentation for future reference. Make sure that this installation & operating manual is available to the operator.

The installation & operating manual is part of the equipment. Please hand over this installation & operating manual when selling the equipment or passing it on.

Formatting features in the document

Certain text elements of this installation & operating manual feature a specific typographic design. You can easily distinguish the following text elements:

Standard text

Cross-reference

- ▶ Listing
 - ▶ Sub-items in listings
- Steps for action.



Here you will find additional useful information and tips serving to assist you in using the equipment to its fullest potential.

Use for the intended purpose

The MSB-1, MSB-1.2 continuous steam trap monitor is used for testing steam traps for loss of steam and banking up of condensate outside potentially explosive atmospheres. It must not be used in potentially explosive atmospheres.

The MSB-1 Ex, MSB-1.2 Ex continuous steam trap monitor is used for testing steam traps for loss of steam and banking up of condensate in potentially explosive atmospheres.

The MSB-1.2 or MSB-1.2 Ex continuous steam trap monitor is designed for use at higher noise levels than the MSB-1 or MSB-1 Ex.

This allows the MSB-1.2 or MSB-1.2 Ex to be used at higher pressures or condensate flowrates than the MSB-1 or MSB-1 Ex.

You can find the precise areas of application of the different versions together with their installation options in the data sheet.

Intended use also includes reading and following all the instructions in this manual and in the MSBN-1/MSBN-1 Ex LoRa node Installation & Operating Manual and, with the MSBN-1 Ex, in the certificate as well. This applies in particular to the safety notes and requirements.

Use for the intended purpose also includes correct handling of the batteries used as described in the LoRa node Installation & Operating Manual. You can obtain information on correct handling from the manufacturer of the LoRa node.

Any other use of the equipment is considered to be improper.

The following use, in particular, is deemed improper use:

- Using equipment without Ex classification in a potentially explosive atmosphere
- Use of the equipment by untrained personnel

Basic safety notes

Explosion hazard

- Use the equipment in areas at risk of gas explosion only under the following conditions:
 - Only use equipment type MSB-1 Ex or MSB-1.2 Ex, consisting of the MSBS-1 Ex sensor, MSBA-1 Ex or MSBA-1.2 Ex pre-amplifier with connecting cable and the MSBN-1 Ex LoRa node in potentially explosive atmospheres.
 - Make sure that all equipment assemblies are free from damage.
 - Only connect the equipment to earthed pipes or steam traps.
 - Never connect or disconnect equipment assemblies in potentially explosive atmospheres.

Exception: The MSBN-1 Ex (Press'0 0-5V) may be disconnected from and connected to the MSBA-1 Ex or MSBA-1.2 Ex in potentially explosive atmospheres.

- Never open equipment assemblies in potentially explosive atmospheres.
- Make sure that no potentially explosive atmosphere is present during installation.
- Minimise electrostatic charge on non-metallic parts of the MSBN-1 Ex LoRa node.
- Pay attention to the safety notes in the enclosed MSBN-1 Ex LoRa node certificate, particularly in relation to the batteries.
- Only replace the battery outside the potentially explosive atmosphere. Only use SAFT LS 17500 batteries.
- Risk of explosion due to sparks. In potentially explosive atmospheres, do not use objects that can produce sparks.

Risk of severe injuries

- ▶ The steam traps being monitored are hot and under pressure. Only work on the steam traps if the following conditions are satisfied:
 - ▶ Avoid skin contact with the monitored steam trap and other plant components.
 - ▶ Wear suitable protective clothing.
 - ▶ Make sure there is no escaping fluid around the steam trap to be monitored.
- ▶ Risk of accident if pressure-bearing screws come loose.
Make sure that pressure-bearing screws are not unscrewed during installation and connection.

Risk of minor injuries

- ▶ There is a risk of cuts from sharp-edged parts of the equipment. Always wear protective gloves when working on the equipment.

Information on property damage or malfunctions

- ▶ Incorrect installation, connection and handling can cause malfunctions and damage to electronic components.
Never open the equipment assemblies.

Qualification of personnel

A qualified person must be acquainted with and experienced in the following:

- ▶ The pertinent on-site rules and regulations for preventing fire and explosions as well as industrial safety regulations
- ▶ Working on pressure equipment
- ▶ Working with dangerous (hot or pressurized) fluids
- ▶ Observing all notes and instructions in this installation & operating manual and the applicable documents
- ▶ Working with portable instruments
- ▶ Working with personal computers (PCs)
- ▶ Working with menu-driven software
- ▶ Working with computer networks

Protective gear

The operator must ensure that anyone working on the equipment must wear the required protective clothing and safety gear stipulated for the site of installation. The protective clothing must be suitable for the used media and must protect the wearer against safety and health hazards associated with a particular job to be carried out at the site of installation. Protective clothing & equipment must provide protection from potential hazards, in particular from injuries to:

- ▶ Head
- ▶ Eyes
- ▶ Body
- ▶ Hand
- ▶ Feet
- ▶ Hearing

Note that this list is not exhaustive. The operator must establish personal protective equipment guidelines and specify any additional protective gear that is required if the worker is exposed to a specific risk at the site of installation.

Typographic features of warning notes



DANGER

Notes with the heading DANGER warn against imminent dangerous situations that can lead to death or serious injuries.



WARNING

Notes with the heading WARNING warn against possibly dangerous situations that could lead to death or serious injuries.



CAUTION

Notes with the heading CAUTION warn against dangerous situations that could lead to minor or moderate injuries.

Formatting features for warnings of property damage

Attention!

This information warns of a situation leading to property damage.

Description

Scope of supply and equipment specification

Scope of supply

The equipment assemblies are supplied individually and must be connected and installed before use.

For MSB-1 or MSB-1.2 equipment, delivery includes the following:

- MSBS-1 Ex sensor
- MSBA-1 or MSBA-1.2 pre-amplifier with connecting cable
- MSBN-1 LoRa node type LSN50 v2

For MSB-1 Ex or MSB-1.2 Ex equipment, delivery includes the following:

- MSBS-1 Ex sensor
- MSBA-1 Ex or MSBA-1.2 Ex pre-amplifier with connecting cable
- MSBN-1 Ex LoRa node type Press'O 0-5V

These assemblies are intended for use in potentially explosive atmospheres. They are marked as such on their name plates.

Equipment specification

MSB-1, MSB-1.2

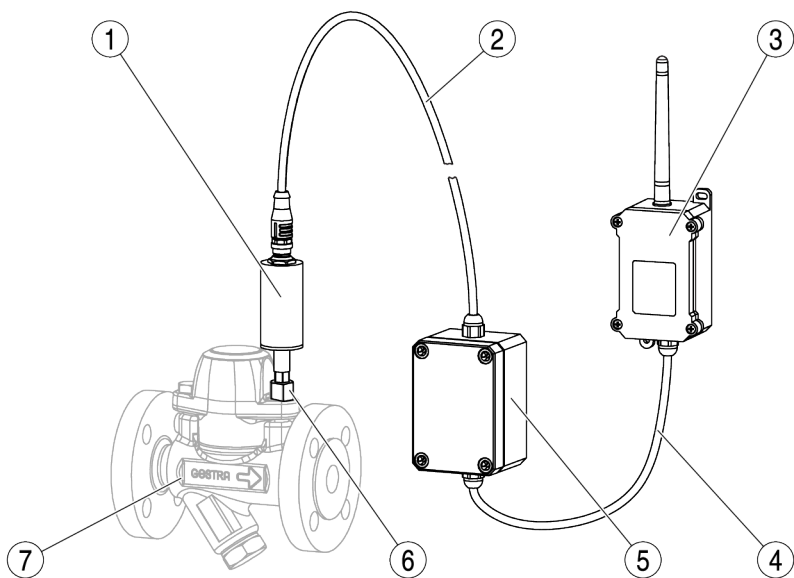

No.	Designation
1	MSBS-1 Ex sensor
2	Connecting cable
3	MSBN-1 LoRa node
4	Connecting cable

No.	Designation
5	MSBA-1, MSBA-1.2 pre-amplifier
6	Pressure-bearing screw (accessory)
7	Steam trap (BK 45 shown here as an example)

MSB-1 Ex, MSB-1.2 Ex

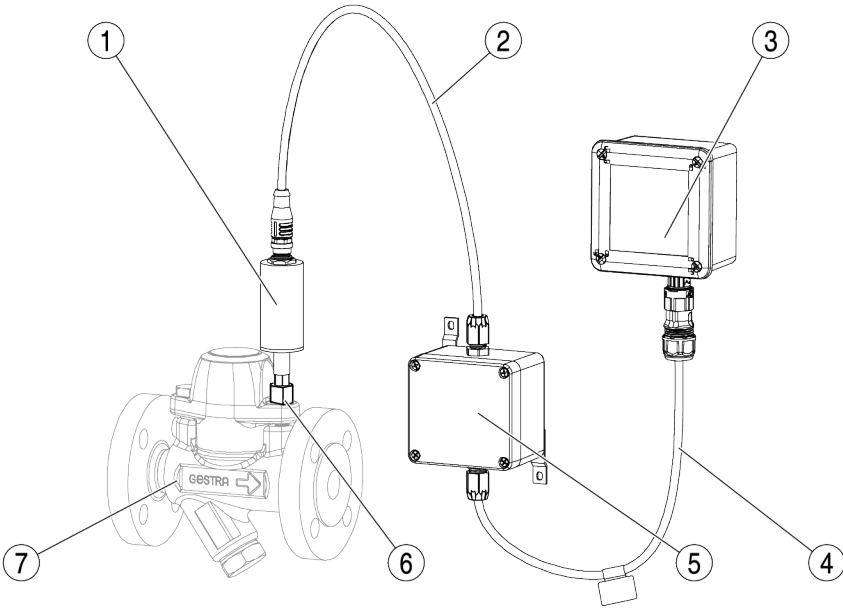

No.	Designation
1	MSBS-1 Ex sensor
2	Connecting cable
3	MSBN-1 Ex LoRa node
4	Connecting cable including equipment name plate

No.	Designation
5	MSBA-1 Ex, MSBA-1.2 Ex pre-amplifier
6	Pressure-bearing screw (accessory)
7	Steam trap (BK 45 shown here as an example)

Optional extras

The following add-on equipment is available:

- ▶ Pressure-bearing screws (PBS) of steel or stainless steel
- ▶ 90° adapter (ADP)
- ▶ Clips (RFC) for mounting on pipes (including clip adapters)
- ▶ Mounting system for pre-amplifier and LoRa node
- ▶ LoRa gateway

Further accessories are available on request.

Name plate

MSB-1 Ex, MSB-1.2 Ex equipment: Name plate on connecting cable from pre-amplifier to MSBN-1 Ex LoRa node

Name plates are affixed to the individual assemblies:

- ▶ MSBS-1 Ex sensor: on the housing (incl. ATEX number)
- ▶ Pre-amplifier
 - ▶ MSBA-1, MSBA-1.2: on the side
 - ▶ MSBA-1 Ex, MSBA-1.2 Ex: on the side (incl. ATEX test number)
- ▶ LoRa node:
 - ▶ Equipment name plate on the front (MSBN-1) or on the side (MSBN-1 Ex)
 - ▶ The Ex-classified equipment (MSBN-1 Ex) also has the ATEX test number on the name plate.

The name plates contain the following indications:

- ▶ Manufacturer
- ▶ Type designation
- ▶ Serial number
- ▶ Admissible ambient temperature
- ▶ QR code

Traceability

The MSB-1 Ex or MSB-1.2 Ex is subject to the traceability requirements of Directive 2014/34/EU.

Therefore, the name plates of these equipment assemblies (sensor, pre-amplifier and LoRa node) have serial numbers.

When the equipment or individual assemblies are purchased, the customer data is linked to the relevant serial numbers, ensuring traceability. If the equipment or individual assemblies are resold or passed on, the vendor is responsible for ensuring that traceability is maintained. To do this, the vendor must archive the new owner's data together with the serial numbers of the equipment/assemblies, and share this data with GESTRA AG if so requested.

The digital name plates are linked to the GESTRA database by scanning the QR code on the equipment housing.

Alternatively, the vendor can also transfer this data directly to GESTRA AG. In this case, the manufacturer, GESTRA AG, will take on the management of the relevant data.

ATEX Directive

MSB-1 Ex and MSB-1.2 Ex equipment is approved for use in potentially explosive atmospheres. You can find more detailed information on the MSBN-1 Ex LoRa node in the Installation & Operating Manual and certificate of this assembly.

The following assemblies are approved for use in potentially explosive atmospheres:

- ▶ MSBS-1 Ex sensor with Ex classification
- ▶ MSBA-1 Ex or MSBA-1.2 Ex pre-amplifier with Ex classification
- ▶ MSBN-1 Ex LoRa node with Ex classification

The MSBS-1 Ex sensor has the following classification:

MSBS-1 Ex

II 2G Ex ib IIC T4 Gb

BVS 23 ATEX E 008 X

The MSBA-1 Ex or MSBA-1.2 Ex pre-amplifier has the following classification:

MSBA-1 Ex or MSBA-1.2 Ex

II 2G Ex ib IIC T4 Gb

BVS 23 ATEX E 008 X

For the classification of the MSBN-1 Ex LoRa node, refer to the section "Equipment specification (MSBN-1 Ex)" and the Installation & Operating Manual of this assembly.

Only MSBS-1 Ex sensors and MSBA-1 Ex or MSBA-1.2 Ex pre-amplifiers may be connected to the MSBN-1 Ex LoRa node.

Only connect the equipment assemblies outside the potentially explosive atmosphere.

Task and function

Purpose

The MSB-1 or MSB-1.2 equipment is used for monitoring steam traps for loss of steam and banking up of condensate.

The MSB-1 Ex or MSB-1.2 Ex equipment is used for monitoring steam traps for loss of steam and banking up of condensate in potentially explosive atmospheres.

The MSB-1.2 and MSB-1.2 Ex equipment is intended for use at higher noise levels, e.g. at higher pressures or condensate flowrates. You can find precise information on the areas of application in the data sheet.

Monitoring enables the early detection of faulty steam traps and banking up of condensate.

The early detection of faulty valves increases the efficiency of the plant as a whole and reduces its energy consumption.

The detection of banked up condensate prevents damage and malfunctions in the plant as a whole.

To use the equipment, a LoRa gateway and LoRa network server are required for displaying readings.

Function

The equipment monitors steam traps using ultrasonic and temperature measurements by a piezo element. These measurements are performed automatically at regular intervals.

The measured data is analysed in the MSBN ... LoRa node and transferred to the LoRa gateway (accessory). The data is transferred by LoRa wireless technology via network protocol.

The measurement results are analysed on the basis of the sound and temperature values and parameters of the steam trap under test. You can find further information on analysis in the network protocol.

Storing and transporting the equipment

Storing the equipment

- Please observe the following items when storing the equipment:
 - ▶ The equipment and all assemblies must be protected against jolts and impacts.
 - ▶ Only store the equipment in enclosed spaces.
 - ▶ Make sure the conditions in the Technical Data on page 26 ff. are complied with.
- Make sure that all these requirements are always met when storing the equipment.
- Please contact the manufacturer if you cannot comply with the recommended storage conditions.

Transporting the equipment

- Meet the requirements for storage also when transporting the equipment.



DANGER

Risk of explosion due to static charging during transport.

- Transport the equipment and all its components only after measurements have confirmed the lack of a potentially explosive atmosphere in the plant.
 - Before transport, make sure that no potentially explosive atmosphere is present.
-
- For transport, adhere to the conditions in the technical data on page 26.
 - When transporting the equipment to the location of use, make sure it is secured against falling and impacts.



DANGER

Risk of fire due to the equipment's lithium metal batteries if the equipment is not transported correctly.

- When transporting the equipment, pay attention to the international rules on the transport of hazardous goods.
-
- When transporting the equipment, pay attention to the international rules on the transport of lithium metal batteries.

Mounting and connecting the equipment

Preparing installation

- Take the equipment out of the transport packaging.
- Check the equipment for transport damage.
- Contact the manufacturer if you detect any kind of shipping damage.



DANGER

Personnel working on pipes are exposed to safety risks and may suffer severe injuries, poisoning or even loss of life.

- Make sure that no hot or hazardous fluid is in the equipment or the pipes.
- Make sure that the pipes upstream and downstream of the equipment are depressurised.
- Make sure that the installation is switched off and protected against unauthorised or unintended activation.
- Make sure that the equipment and the pipes have cooled down to room temperatures.
- Wear protective clothing that is suitable for the fluid and, if necessary, wear protective gear.

For more information on suitable protective clothing and safety gear refer to the safety data sheet of the fluid in question.



DANGER

Risk of explosion due to static electricity on plant components.

- Before starting work, take suitable measures to ensure that no plant parts are live or statically charged.
- Only install the equipment on earthed pipes or steam traps.

- Make sure that there is no potentially explosive atmosphere at the installation site.



WARNING

Risk of electric shock when working on a pipe that is live.

- Before starting work, take suitable measures to ensure that no parts of the pipe are live.
- Only install the equipment on earthed pipes or steam traps.

- Drain pipes until they are empty.
- Switch the installation off and protect it against unauthorised or unintended re-activation.

You will need the following tools to install and connect the equipment

- Size 10 combination spanner, DIN 3113, form B
- Size 16 combination spanner, DIN 3113, form B
- Size 17 combination spanner, DIN 3113, form B
- Size 10 torque wrench, 2.5–25 Nm, ISO 6789
- Size 16 torque wrench, 2.5–25 Nm, ISO 6789
- Size 17 torque wrench, 2.5–25 Nm, ISO 6789
- Phillips screwdriver, 2.5 Nm

- Make sure the required tools are to hand.

Mounting the equipment



DANGER

Risk of explosion due to static electricity on plant components.

- Make sure that no potentially explosive atmosphere is present at the installation site.



DANGER

Incorrectly connected equipment can cause fatal accidents or severe injuries.

- Make sure that only qualified skilled personnel connect the equipment to pipes.

Specialist personnel must be highly qualified and fully experienced in making pipe connections for the respective type of end connection.



CAUTION

There is a risk of injury from sharp edges of fastening materials.

- Wear suitable protective clothing, especially sturdy gloves, during installation.

Attention!

The fastenings of vibrating plant parts may become detached if improperly fastened.

- If the mounting system is fastened to vibrating plant parts, the use of threadlocker (e.g. Loctite) is recommended for the MSBA and MSBN.

- Make sure that the pipe system of the plant is clean.

You can install the equipment sensor in the following locations:

- In a pressure-bearing screw (PBS), in place of a cover screw in the steam trap
- Fastened to the pipe by a clip

The pressure-bearing screw (PBS) is available as an accessory.

Fitting the sensor to the steam trap



DANGER

A loose pressure-bearing screw can lead to accidents resulting in very serious injury or death.

- Make sure that pressure-bearing screws do not come loose during installation and connection.

The sensor with pressure-bearing screw (PBS) is attached to the outlet side of the thermostatic steam trap in place of the cover screw.

- Undo both cover screws on the steam trap (7).
- Remove the cover screw (8) on the outlet side.
- Check that the gasket is in perfect condition.
- Replace the gasket if necessary, as described in the steam trap Installation & Operating Manual.
- Insert the pressure-bearing screw (6) in the thread.
- Alternately tighten the cover screw and pressure-bearing screw to a torque of 25 Nm.
- With your hand, screw the MSBS ... sensor (1) into the pressure-bearing screw (6).
- Tighten the MSBS ... sensor to a torque of 2.5 Nm.

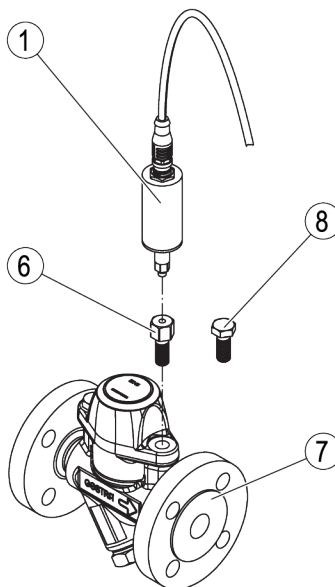

Clipping the sensor to a pipe



DANGER

Risk of explosion due to static electricity on plant components.

- Make sure that the clip has an electrical connection to the earthed pipe.

Mount the MSBS sensor ... (1) on the pipe using a clip. Clips in various sizes are available as accessories. The adapter (12) includes a clip for fastening it.

The location of the sensor on the pipe must meet the following conditions:

- ▶ The sensor must be upstream of the test object.
 - ▶ The distance between the sensor and the test object must not exceed 20 cm.
 - ▶ Do not fit the sensor to an insulated section of pipe.
- Fit the clip (11) in a suitable location on the pipe.
 - Tighten the screw (10) of the clip to a torque of 2.5 Nm.
 - Screw the adapter into the thread of the clip.
 - Tighten the adapter to a torque of 2.5 Nm.
 - Screw the MSBS ... sensor (1) into the thread of the adapter (12).
 - Tighten the sensor to a torque of 2.5 Nm.

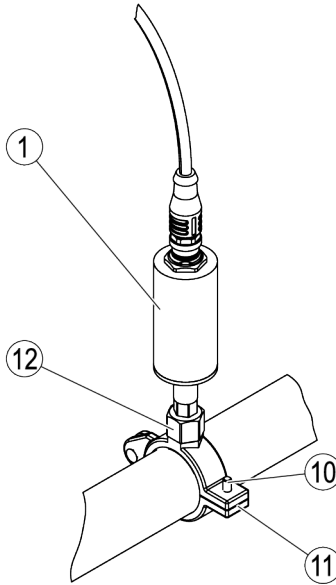

Installing the MSBA ... pre-amplifier

Attention!

Incorrect installation can cause damage to cables or incorrect readings.

- Fit the MSBA ... pre-amplifier (5) in a location with a maximum temperature of 50 °C.
- Fit the pre-amplifier so that the cable can be connected without strain.

- Fit the MSBA ... pre-amplifier (5) in a suitable location.

This could be an insulated pipe, a wall or a mounting panel, for example, at a sufficient distance from the heat source.

- Connect the cable (2) of the pre-amplifier (5) to the socket of the sensor (1), making sure it is not under strain.

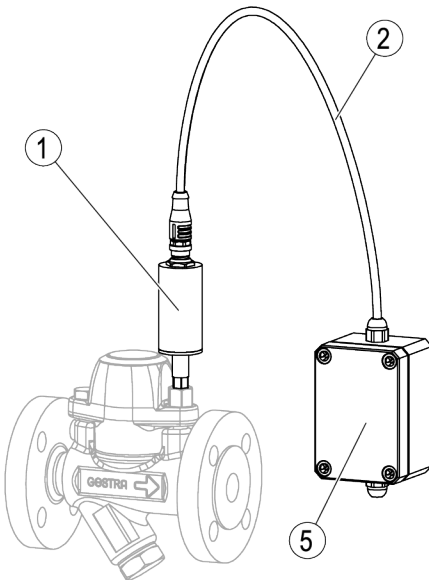

Installing the MSBN ... LoRa node

Attention!

Incorrect installation can cause damage to cables or incorrect readings.

- Fit the LoRa node (3) in a location with a maximum temperature of 50 °C.
- Fasten the LoRa node so that the cable can be connected without strain.

- Fit the LoRa node (3) in a suitable location.

This could be an insulated pipe, a wall or a mounting panel, for example, at a sufficient distance from the heat source.

- Connect the cable (4) of the pre-amplifier (5) to the socket of the LoRa node (3).

With the MSB-1 or MSB-1.2, the pre-amplifier is already connected to the LoRa node on delivery.

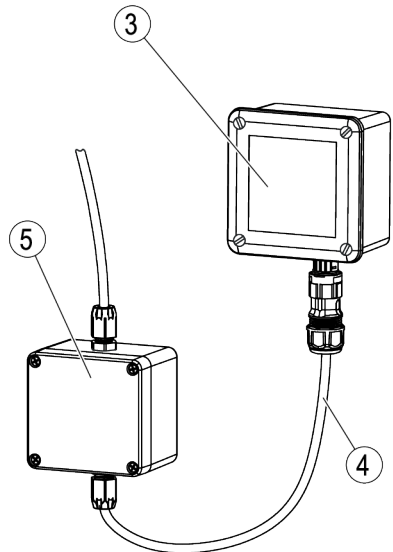

Starting up the equipment



DANGER

Risk of explosion due to static electricity on plant components.

- Minimise electrostatic charge on non-metallic parts of the MSBN-1 Ex LoRa node.

Registering the equipment

When the LoRa node is switched on, it can distinguish between equipment with and without Ex classification:

Equipment without explosion protection (MSBN-1 LoRa node) is switched on by setting a jumper on the PCB. Equipment with explosion protection (MSBN-1 Ex LoRa node) must be switched on using a magnet.

- Make sure that a configured LoRa gateway is available.

You can find information on the LoRa gateway in the supplied manufacturer's instruction manual.

- Switch on the LoRa node as described in the manufacturer's Installation & Operating Manual.

When the MSBN-1 Ex LoRa node is switched on, two LEDs indicate the operating state. During the booting process, the red LED on the equipment flashes rapidly.

- When the green LED starts flashing at five-second intervals, you can remove the magnet.

When the MSBN-1 Ex LoRa node is switched on, the green LED lights up for three seconds. Once it is on, the LoRa node automatically connects to the LoRa gateway.

For use, the equipment assemblies must be registered in the GESTRA MSB web application. This also applies if you do not want to register the LoRa node with the GESTRA network server. To register, you must create a client account and log on.

To do this, you will need the GESTRA MSB web application and the QR code on the housing. You can find further information in the supplied documents and on the website www.gestra.com.

Proceed as follows to create the necessary client account:

- Go to the website crp.gestra.com using your preferred browser.
- To create a new client account, follow the on-screen instructions.
- If you have already created a client account, log in with your user credentials.

Proceed as follows to register the assemblies:

- Open the link to the GESTRA MSB web application on the website crp.gestra.com.
- Log in with your user credentials.

You can copy the necessary equipment data from the digital name plate using the QR code.

- Enter your equipment data as directed by the on-screen instructions.

Connecting your equipment to the LoRa network server

The network login credentials are supplied with the LoRa node. You can find further information in the network server documentation.

Proceed as follows to connect the LoRa node to the network server:

- Register the LoRa node in the GESTRA web application (see page 16).
- Install the LoRa node as described in the supplied manufacturer's instruction manual.
- Register the LoRa node with the LoRa network server.

Possible network servers are LORIOT or The Things Network, for example. However, you can also register the LoRa node with the GESTRA LoRa network server using the GESTRA web application.

- To do this, follow the supplied manufacturer's instructions.

To register the LoRa node with your own LoRa network server, you will need the following data:

- ▶ DevEUI: 16 hex digits (e.g. 0123456789ABCDEF)
- ▶ AppEUI: 16 hex digits (e.g. 0123456789ABCDEF)
- ▶ AppKEY: 32 hex digits (e.g. 0123456789ABCDEF0123456789ABCDEF).

This data can be found on a sticker in the packaging, via the QR code, or can be sent in a separate list.

The LoRa node is linked to a LoRa gateway. The data is transferred to the LoRa network at regular intervals.

Operation

You cannot perform work on the equipment during operation.

The readings are taken automatically at regular intervals. During data acquisition, the LED on the pre-amplifier lights up.

Please refer to the supplied documentation for information on evaluating readings.

You can analyse the tests using the data analysis app. You can find further information in the operating instructions supplied with this app.

After operation



DANGER

Risk of explosion due to static electricity on plant components.

- ▶ Make sure that no potentially explosive atmosphere is present at the installation site.



WARNING

Risk of electric shock when working on a pipe that is live.

- ▶ Before starting work, take suitable measures to ensure that no parts of the pipe are live.
- ▶ Only perform work on earthed pipes.

Switching the equipment off

The LoRa node only needs to be switched off for taking out of service or in the event of a malfunction. When it is switched on, it determines whether or not the connected equipment has Ex classification.

- ▶ To switch off a LoRa node without Ex classification, open the housing.
- ▶ Remove the jumper as described in the supplied manufacturer's Installation & Operating Manual.
- ▶ To switch off a LoRa Node with Ex classification, hold a magnet against the housing for five seconds.

The LED on the Ex-classified equipment flashes slowly five times and the equipment switches off.

Removing external dirt deposits



DANGER

Risk of explosion due to static electricity on plant components.

- Minimise electrostatic charge on non-metallic parts of the MSBN-1 Ex LoRa node.
- Only clean the NSBN-1 Ex LoRa node assembly outside potentially explosive atmospheres.

Attention!

If fluids penetrate the equipment it may get damaged.

- Make sure that fluids cannot get into the equipment.
- Use only a slightly moistened cloth to clean the equipment.

- To remove dirt deposits rinse the equipment with fresh water and wipe it with a clean, lint-free cloth.
- To remove any persistent residues use a cleaning agent that is suitable for the material and carefully wipe the equipment with a clean, lint-free cloth.

Maintaining the equipment

The equipment does not require any particular maintenance.

Checking the component parts for damage

- Check that all equipment assemblies are in perfect condition before and after use.
- Do not bring damaged assemblies into service.
- Replace damaged assemblies.

Servicing the equipment and installing spare parts

If an assembly is defective, it must be replaced.

- Register replaced assemblies with the network.
- Replace components only with genuine spare parts from the manufacturer.



DANGER

Risk of explosion due to static electricity on plant components.

- Make sure that no potentially explosive atmosphere is present at the installation site.
-

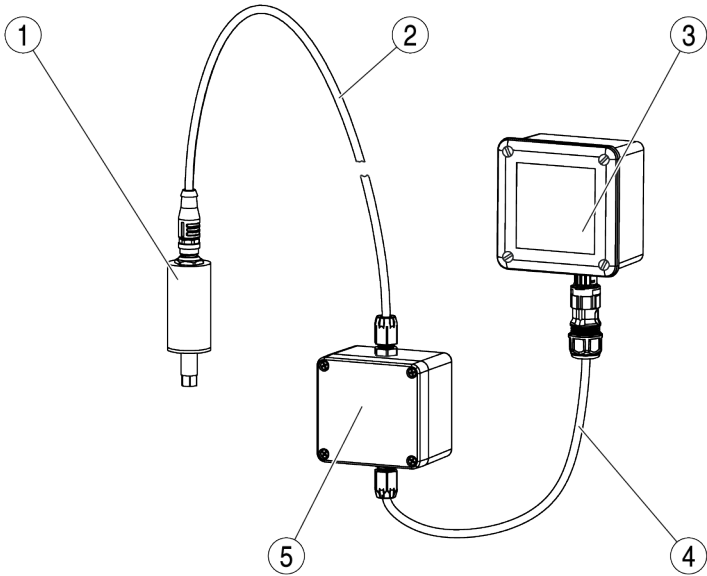

MSB-1 and MSB-1 Ex spare parts

No.	Designation	Stock code	
		MSB-1	MSB-1 Ex
1	MSBS-1 Ex sensor	442010	
2, 4, 5	MSBA-1 Ex pre-amplifier with connecting cable	–	442023
2, 3, 4, 5	Pre-amplifier MSBA-1 EU/UK, LoRa node MSBN-1 EU/UK	442026	–
3	LoRa node MSBN-1 Ex EU/UK	–	442033

MSB-1.2 and MSB-1.2 Ex spare parts

No.	Designation	Stock code	
		MSB-1.2	MSB-1.2 Ex
1	MSBS-1 Ex sensor	442010	
2, 4, 5	MSBA-1.2 Ex pre-amplifier with connecting cable	–	442025
2, 3, 4, 5	Pre-amplifier MSBA-1.2 EU/UK, LoRa node MSBN-1 EU/UK	442038	–
3	LoRa node MSBN-1 Ex EU/UK	–	442033

Troubleshooting

Problem	Cause	Action
Cannot log in to the LoRa network server.	Login credentials not available.	Contact Support.
	Wrong login credentials entered.	Check entered values: DevEUI: 16 hex digits AppEUI: 16 hex digits AppKEY: 32 hex digits
LoRa node cannot be switched on.	The battery is empty.	Replace the assembly.
	Repeat the switch-on sequence.	MSB-1: Check jumper MSB-1 Ex: Use a different magnet.
LoRa node does not send any data.	LoRa node is not registered.	Set up the LoRa node again and register it.
	The battery is empty.	Replace the assembly.
	Poor reception of transferred data.	Change the installation location of the LoRa node or the gateway. With the MSB-1, ensure the supplied antenna is mounted correctly.
	Firewall prevents the gateway from communicating with the network server (only if using Ethernet/Wi-Fi).	Check your firewall settings.
	Gateway has no mobile phone coverage (only if using GSM/LTE).	Insert a SIM card and have it activated by the network operator. Make sure the gateway has mobile network coverage and is correctly positioned.
LoRa node only sends data sporadically (not hourly).	LoRa wireless coverage insufficient.	Check the spreading factor and change the installation position of the LoRa node or gateway if necessary. With the MSB-1, make sure the supplied antenna is mounted correctly. If just individual data packages are missing (e.g. one per week), this is not an error. If necessary, enable and configure the "Confirmed Messaging" function. This will lead to increased battery usage, however.

Problem	Cause	Action
LoRa node sends implausible data.	Pre-amplifier or sensor is not connected.	Compare data with a reference measurement using a VKP. Ensure the LoRa node, pre-amplifier and sensor are correctly connected. Contact the manufacturer. Replace equipment assemblies if necessary.
LoRa node issues an ambient temperature warning or ambient temperature error.	Ambient temperature is too high or too low.	Check the ambient temperature. If necessary, choose a different position for the LoRa node.
LoRa node issues a temperature warning or temperature error.	Pre-amplifier or sensor is not connected.	Ensure the LoRa node, pre-amplifier and sensor are correctly connected.
	Sensor open circuit or short circuit.	Check the wiring between the LoRa node, pre-amplifier and sensor.
LoRa node issues a battery warning or battery error.	The battery is empty.	Replace the assembly.
LoRa node issues a piezo warning or piezo error.	Pre-amplifier or sensor is not connected.	Ensure the LoRa node, pre-amplifier and sensor are correctly connected.
QR codes cannot be read.	Wrong distance or poor lighting.	Adjust the distance or lighting.
"Live steam leakage" is displayed even though the steam trap is intact.	Wrong equipment version (MSB-1 (Ex) or MSB-1.2 (Ex)) selected.	Use a different equipment version.
"Steam trap OK" is displayed even though the steam trap is faulty.	Wrong equipment version (MSB-1 (Ex) or MSB-1.2 (Ex)) selected.	Use a different equipment version.



MSBN-1 Ex: LEDs on the LoRa node provide further information on the operating state. You can find information on the LEDs and their meaning in the supplied manufacturer's instructions.

- If you are unable to remedy the problem with the help of these instructions, please contact the manufacturer, GESTRA.

Putting the equipment out of operation

The LoRa node only needs to be switched off for taking out of service or in the event of a malfunction. When it is switched on, it determines whether or not the connected equipment has Ex classification.

- To switch off a LoRa node without Ex classification, open the housing.
- Remove the jumper as described in the supplied manufacturer's Installation & Operating Manual.
- To switch off a LoRa Node with Ex classification, hold a magnet against the housing for five seconds.

The LED on the Ex-classified equipment flashes slowly five times and the equipment switches off.



WARNING

Risk of electric shock when working on a pipe that is live.

- Before starting work, take suitable measures to ensure that no parts of the pipe are live.
- Only perform work on earthed pipes.

Removing the equipment



DANGER

Risk of explosion due to sparks if cables are disconnected!

- Always disconnect the cables of assemblies outside the potentially explosive atmosphere.

Exception: The MSBN-1 Ex (Press'O 0-5V) may be disconnected from and connected to the MSBA-1 Ex in the potentially explosive atmosphere.



DANGER

Risk of explosion due to static electricity on plant components.

- Only perform work on plant parts that are earthed.

- Make sure that there is no potentially explosive atmosphere at the installation site.



DANGER

Personnel working on pipes are exposed to safety risks and may suffer severe injuries, poisoning or even loss of life.

- Make sure that no hot or hazardous fluid is in the equipment or the pipes.
- Make sure that the pipes upstream and downstream of the equipment are depressurised.
- Make sure that the installation is switched off and protected against unauthorised or unintended activation.
- Make sure that the equipment and the pipes have cooled down to room temperatures.
- Wear protective clothing that is suitable for the fluid and, if necessary, wear protective gear.

For more information on suitable protective clothing and safety gear refer to the safety data sheet of the fluid in question.

- Remove the sensor in reverse order to steam trap installation.
- If necessary, fit the screw to the cover of the steam trap, as described in the steam trap Installation & Operating Manual.
- Install the LoRa node in reverse order to installation.
- Take the still connected assemblies out of the potentially explosive atmosphere.
- Only disconnect the cables from the sensor and the LoRa node when they are outside the potentially explosive atmosphere.
- Store the equipment as described on page 11.

Returning the equipment

You can return the equipment to your contractual partner.

- Make sure that all harmful substances are removed from the equipment.
- Pay attention to the instructions in section "Transporting the equipment" from page 11.
- Pack the equipment in its original packaging or in suitable transport packaging.

The transport packaging must protect the equipment from damage in the same way as the original packaging.

- Send the completed and signed declaration of decontamination with the equipment. The declaration of decontamination must be attached to the packaging so that it is accessible from the outside.
- Register the return delivery with your contractual partner before returning the equipment.

Disposing of the equipment



CAUTION

Environmental damage may be caused by poisonous fluid residues.

- Before disposing of the equipment make sure that it is clean and free of fluid residues.
- For the disposal of all materials observe the pertinent legal regulations concerning waste disposal.

The equipment is made from the following materials:

Component	Material
Housing of MSBS-1 Ex sensor	1.4305
Housing of MSBA-1, MSBA-1.2 pre-amplifier	Polycarbonate GF10
Housing of MSBA-1 Ex, MSBA-1.2 Ex pre-amplifier	Polyester
MSBN-1, MSB-1 Ex LoRa node	See LoRa node documentation
Battery	Lithium metal battery (Li-SOCl ₂)



You can find information on the materials of the assemblies in the supplied manufacturer's documentation.

The equipment and its assemblies contain electronic parts.

Technical data

Dimensions and weights

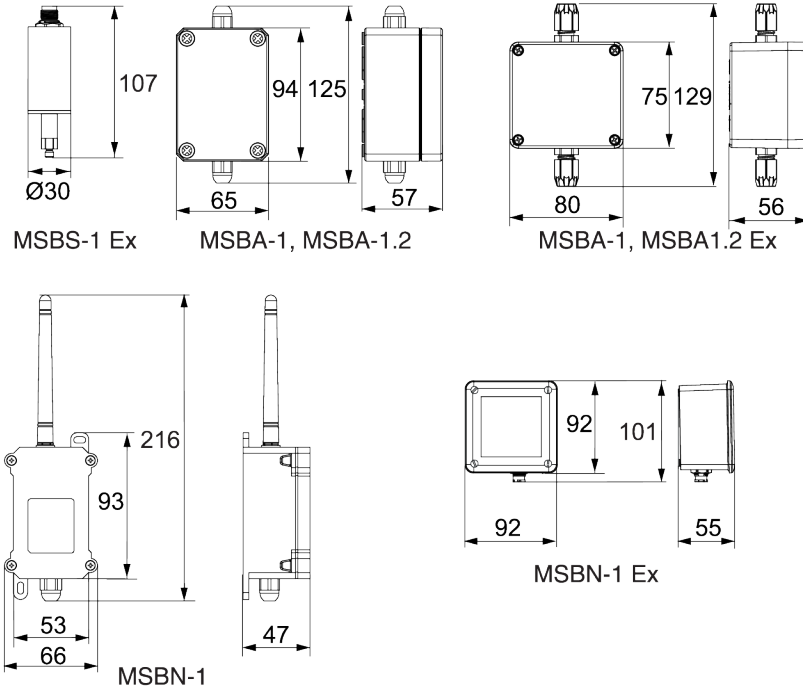

Dimensions [mm]

Assembly	Dimensions mm			Weight g
	Length/height	Width/diameter	Depth	
MSBS-1 Ex sensor	107	30	–	160
MSBA-1, MSBA-1.2 pre-amplifier	94	65	57	270 ¹
MSBA-1 Ex, MSBA-1.2 Ex pre-amplifier	75	80	56	430 ¹
Cable (sensor–pre-amplifier)	800	–	–	–
Cable (pre-amplifier–LoRa node)	200	–	–	–
MSBN-1 LoRa node	216	66	47	190
MSBN-1 Ex LoRa node	See Installation & Operating Manual of the assembly			

1 includes cable

Electrical data

Assembly	Supply voltage	Protection class	Overvoltage category
MSBS-1 Ex sensor	–	III (SELV)	I
MSBN-1 LoRa node	3.6 V		
MSBN-1 Ex LoRa node	See Installation & Operating Manual of the assembly		
MSBA-1 or MSBA-1.2 pre-amplifier	5.0 V / 5 mA		
MSBA-1 Ex or MSBA-1.2 Ex pre-amplifier			

Battery life with one measurement per hour: approx. 10 years in ideal conditions (SF7, constant ambient temperature of 20 °C)

Assembly	Wireless device class	Maximum output power	Frequency range	Detection range
MSBN-1 EU/UK MSBN-1 Ex EU/UK	LoRaWAN Class A	+14 dBm / 25 mW	LoRaWAN network protocol 863–870 MHz	Depending on installation location and gateway position. (Up to 3 km in urban areas, up to 10 km in rural areas)

Ambient conditions

Area of application	Indoors and outdoors
Maximum altitude	2,000 m
Protection against ingress of foreign bodies	Suitable for industrial use
Pollution degree	4
Admissible ambient temperature	–20 — 50 °C

Pressure & temperature ratings

MSB-1, MSB-1 Ex

Assembly	Storage/ operating temperature °C	IP rating
MSBS-1 Ex sensor ¹	-20 — 50	IP64
MSBA-1 pre-amplifier		IP66
MSBA-1 Ex pre-amplifier		IP66
MSBN-1 LoRa node ²		IP68
MSBN-1 Ex LoRa node ²	See Installation & Operating Manual of the assembly	

- 1 The temperature of the fluid in the steam trap must not exceed 240 °C.
- 2 Battery life with one measurement per hour: approx. 10 years

MSB-1.2, MSB-1.2 Ex

Assembly	Storage/ operating temperature °C	IP rating
MSBS-1 Ex sensor ¹	-20 — 50	IP64
MSBA-1.2 pre-amplifier		IP66
MSBA-1.2 Ex pre-amplifier		IP66
MSBN-1 LoRa node ²		IP68
MSBN-1 Ex LoRa node ²	See Installation & Operating Manual of the assembly	

- 1 The temperature of the fluid in the steam trap must not exceed 240 °C.
- 2 Battery life with one measurement per hour: approx. 10 years

Declaration of Conformity – Standards and Directives

You can find details on the conformity of the equipment and the applicable standards and directives in the Declaration of Conformity and the relevant certificates.

You can download the latest Declaration of Conformity at www.gestra.com. You can request the relevant certificates by writing to the following address:

GESTRA AG

Münchener Straße 77

28215 Bremen

Germany

Phone +49 421 3503-0

Fax +49 421 3503-393

e-mail info@de.gestra.com

Web www.gestra.com

Modifications to the equipment not approved by us will invalidate the Declaration of Conformity and the certificates.



You can find our authorized agents around the world at: www.gestra.com

GESTRA AG

Münchener Strasse 77
28215 Bremen
Germany

Phone +49 421 3503-0
Fax +49 421 3503-393
e-mail info@de.gestra.com
Web www.gestra.com

UK Importer

GESTRA UK Ltd

Unit 1 Sopwith Park, Royce Close,
West Portway Business Park, Andover,
Hampshire SP10 3TS
United Kingdom

850910-01/10-2023 kx_mm (809196-02) © GESTRA AG Bremen Printed in Germany