

Ball Float Steam Trap

UNA 14

UNA 16

UNA 16A

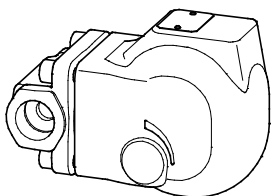

Float trap for compressed air line
drainage

UNA 14P

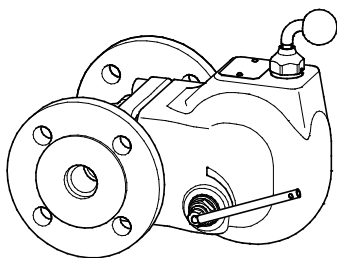

Contents

Foreword	3
Availability.....	3
Formatting features in the document	3
Safety	3
Use for the intended purpose	3
Basic safety notes	4
Information on property damage or malfunctions	4
Typographic features of warning notes.....	5
Formatting features for warnings of property damage	5
Description	6
Scope of supply and equipment specification	6
Task and function	9
Storing and transporting the equipment	10
Storing the equipment	10
Transporting the equipment	10
Mounting and connecting the equipment	11
Preparing installation	11
Connecting the equipment	12
Operation	13
After operation	13
Removing external dirt deposits.....	13
Maintaining the equipment.....	14
Servicing the equipment and installing spare parts	17
Changing the position of installation.....	21
Troubleshooting	22
Putting the equipment out of operation	24
Removing harmful substances.....	24
Removing the equipment	24
Re-using equipment after storage.....	25
Disposing of the equipment.....	25
Technical data	27
Dimensions and weights	27
Pressure & temperature ratings.....	28
Manufacturer's declaration	30

Foreword

This installation & operating manual will help you use the following types of equipment safely and efficiently for their intended purpose.

- ▶ Ball float steam trap UNA 14
- ▶ Float trap for compressed air line drainage UNA 14P
- ▶ Ball float steam trap UNA 16
- ▶ Ball float steam trap UNA 16A (stainless steel)

These types will be called equipment in this document.

This installation & operating manual is intended for anyone commissioning, using, operating, servicing, cleaning or disposing of this equipment and, in particular, for professional after-sales service technicians, qualified personnel and authorised and trained staff.

All of these persons must read and understand the content of this installation & operating manual.

Following the instructions given in this installation & operating manual helps avoiding danger and increases the reliability and service life of the equipment. Please note that in addition to the instructions given in this installation & operating manual you must also observe all locally applicable rules and regulations concerning the prevention of accidents as well as approved safety guidelines for good professional practice.

Availability

Keep this installation & operating manual together with the plant documentation for future reference. Make sure that this installation & operating manual is available to the operator.

The installation & operating manual is part of the equipment. Please hand over this installation & operating manual when selling the equipment or passing it on.

Formatting features in the document

Certain text elements of this installation & operating manual feature a specific typographic design. You can easily distinguish the following text elements:

Standard text

Cross-reference

- ▶ Listing
 - ▶ Sub-items in listings
- Steps for action.



Here you will find additional useful information and tips serving to assist you in using the equipment to its fullest potential.

Safety

Use for the intended purpose

The UNA 14, UNA 16 and UNA 16A are designed for draining condensate from steam or gas systems.

The UNA 14P is designed for draining condensate from compressed air or gas systems.

Equipment with control unit SIMPLEX R and DUPLEX are also designed for air venting the installation.

Equipment with control unit SIMPLEX - if installed in inverted position - can vent gas or air from liquids.

The equipment must only be used within the allowable pressure and temperature limits and only if the chemical and corrosive influences on the equipment are taken into account.

Do not expose the thermostatic capsule of equipment with a DUPLEX control unit to superheat conditions above 5 °C.

Correct use includes compliance with the instructions given in this installation & operating manual, in particular obedience to all safety instructions.

Any other use of the equipment is considered to be improper.

Note that the equipment is also used incorrectly if the materials of the equipment are not suitable for the fluid.

Basic safety notes

Risk of severe injuries

- ▶ The equipment is under pressure and hot during operation. Before carrying out any work on the equipment make sure that the following requirements are met:
 - ▶ The pipes must be depressurized (0 bar).
 - ▶ The fluid must be completely removed from the pipes and the equipment.
 - ▶ During work on the equipment the installation must be switched off and protected against unauthorised or unintended activation.
 - ▶ The pipes and the equipment must have cooled down to room temperature (approx. 20 °C).
- ▶ If the equipment is used in contaminated areas there is a risk of severe injuries or death caused by harmful substances in or on the equipment. Before working on the equipment make sure that it is completely decontaminated. Always wear the protective clothing prescribed for contaminated areas when working on the equipment.
- ▶ The equipment must only be used with fluids that do not attack the material and the gaskets and sealings of the equipment. Otherwise leaks may occur and hot or toxic fluid could escape.
- ▶ The equipment and its component parts must only be mounted or removed by qualified personnel. A qualified person must be acquainted with and experienced in the following:
 - ▶ Making pipe connections.
 - ▶ Working with dangerous (contaminated, hot or pressurized) fluids.
- ▶ If the admissible temperature and pressure limits are exceeded the equipment may be destroyed and hot or pressurized fluid may

escape. This presents the risk of severe injuries or death. Make sure that the equipment is only operated within the admissible service range. For more information on limits and pressure & temperature ratings see name plate and the section "*Technical Data*".

Risk of minor injuries

- ▶ Sharp edges on internals present the danger of cuts to hands. Always wear industrial gloves when servicing the equipment.
- ▶ If the support of the equipment during installation is insufficient the equipment might fall down, thereby causing bruises or injuries. Make sure the equipment is safely held in place during installation and cannot fall down. Wear protective safety footwear.

Information on property damage or malfunctions

- ▶ Malfunctions will occur if the equipment is installed in a wrong position or with the flow arrow pointing in the opposite direction of the fluid flow. This may result in damage to the equipment or the installation. Make sure that the flow arrow on the equipment body matches the indicated direction of the fluid flow in the pipe.
- ▶ If the material is unsuitable for the fluid, increased wear may occur and fluid may escape. Make sure that the material is suitable for the fluid used in your installation.

Typographic features of warning notes



DANGER

Notes with the heading DANGER warn against imminent dangerous situations that can lead to death or serious injuries.



WARNING

Notes with the heading WARNING warn against possibly dangerous situations that could lead to death or serious injuries.



CAUTION

Notes with the heading CAUTION warn against dangerous situations that could lead to minor or moderate injuries.

Formatting features for warnings of property damage

Attention!

This information warns of a situation leading to property damage.

Description

Scope of supply and equipment specification

Scope of supply

Our equipment is delivered packed and ready for assembly.

Equipment specification

For the designation of the individual component parts please refer to the following pages.

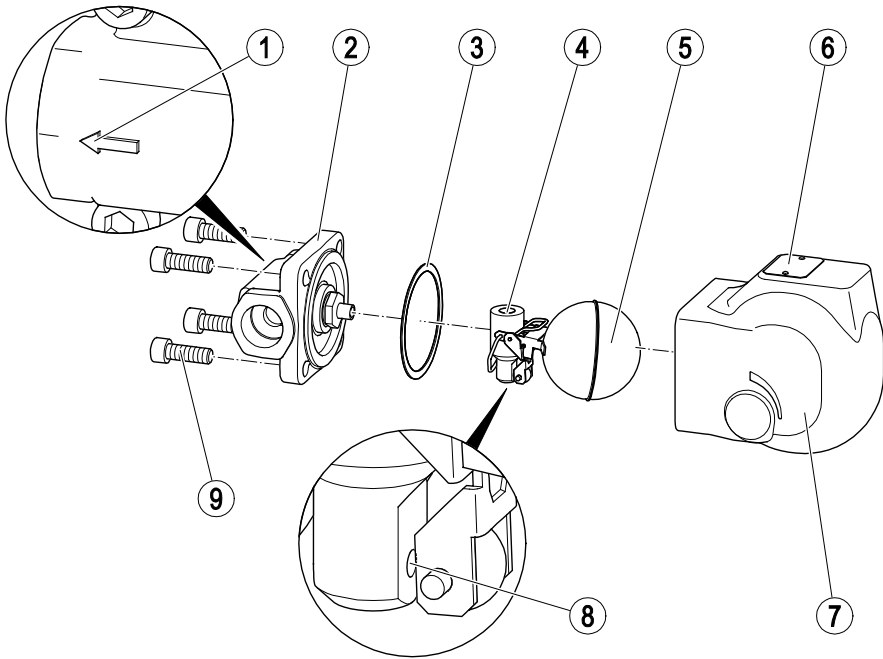

No.	Designation
1	Flow arrow
2	Body
3	Gasket
4	Control unit (here: type SIMPLEX)
5	Float

No.	Designation
6	Name plate
7	Cover
8	Orifice in shut-off unit
9	4 socket-head cap screws

Optional extras

The following types of control unit are available:

- ▶ SIMPLEX with level-dependant float control
- ▶ SIMPLEX R with level-dependant float control and permanent gas venting
- ▶ DUPLEX with level-dependant float control and automatic venting of steam systems

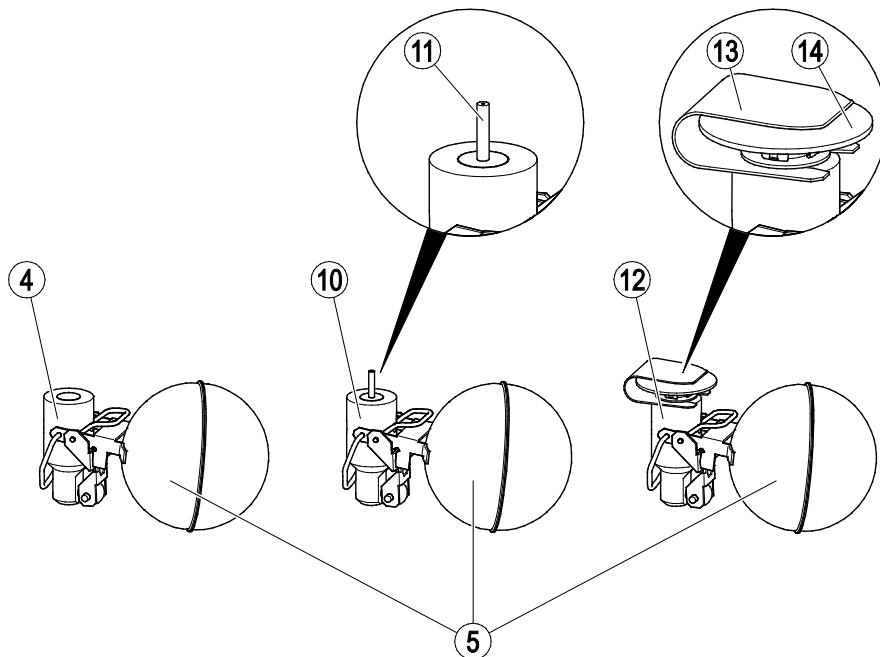

No.	Designation
4	Control unit SIMPLEX or SIMPLEX P
5	Float
10	Control unit Simplex R
11	Permanent air vent (tube)

No.	Designation
12	Control unit DUPLEX
13	Retainer for thermostatic capsule
14	Thermostatic capsule 5N2

The following types of UNA 14P are available:

- ▶ SIMPLEX with level-dependent float control with rolling ball made from stainless steel
- ▶ SIMPLEX P with level-dependent float control with rolling ball made from Perbunan[®]

The following items are available as optional extra:

- ▶ Hand vent valve
- ▶ Float-lifting lever with lever extension (standard with UNA 14P)

The vent hole in the cover for the hand-vent valve can also be used for connecting a balance line.

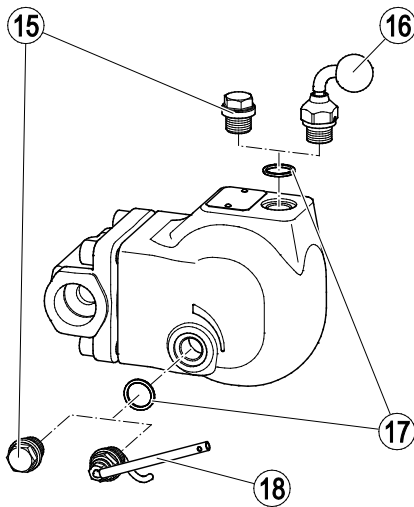

No.	Designation
15	Sealing plug
16	Hand vent valve
17	Gasket
18	Float-lifting lever with lever extension

The control unit is available with different types of orifices

Orifice-number	UNA 14	UNA 14P	UNA 16	UNA 16A
Orifice 4	X	–	X	X
Orifice 13	X	X	X	X
Orifice 22	–	–	X	X

End connections

The equipment is available with the following end connections:

- ▶ Flanges
- ▶ Screwed sockets
- ▶ Butt-weld ends via transition pieces
- ▶ Socket-weld ends

Name plate

The indications on the name plates vary according to the equipment type.

The name plate may specify the following:

- ▶ Manufacturer
- ▶ Type designation
- ▶ Design
- ▶ Nominal size
- ▶ Pressure rating
- ▶ Design temperature
- ▶ Max. service temperature
- ▶ Max. service pressure
- ▶ Orifice or max. admissible differential pressure
- ▶ Installation position

The following items are indicated on the equipment body:

- ▶ Material
- ▶ Identification marking of material testing
- ▶ Batch code
- ▶ Direction of flow

The manufacturing date is located at different positions depending on the equipment type.

- ▶ on the name plate
- ▶ on the body next to the name plate
- ▶ on the body next to the connection

The manufacturing date is stated as quarter and year of the production.

Example: "3/10" reads: manufactured in the third quarter of 2010.

The following items are indicated on the end connections:

- ▶ Flange size
- ▶ Flange face type (RJ number)
- ▶ Thread type

Application of European Directives

Pressure Equipment Directive

The equipment conforms to this directive (see "Manufacturer's Declaration" section) and can be used for the following media:

UNA 14, UNA 14P:

- ▶ Fluids of group 2

UNA 16, UNA 16A (stainless steel):

- ▶ Fluids of group 1
- ▶ Fluids of group 2

ATEX Directive

The equipment does not have its own potential ignition source and is not subject to this directive (see "Manufacturer's Declaration" section).

When installed, static electricity may arise between the equipment and the connected system.

When used in potentially explosive atmospheres, the plant manufacturer or plant operator is responsible for discharging or preventing possible static charge.

If it is possible for medium to escape, e.g. through actuating mechanisms or leaks in threaded joints, the plant manufacturer or plant operator must take this into consideration when dividing the area into zones.

Task and function

Purpose

This equipment is designed for draining condensate and liquids from steam or gas systems.

The UNA 14P is designed for draining condensate from compressed air or gas systems.

Equipment with control unit SIMPLEX R or DUPLEX are also designed for air venting the installation.

Equipment with control unit SIMPLEX can also be used for venting gases from liquids when installed in an inverted position.

Function

The ball float opens the orifice as a function of the liquid level. A rising level results in a proportional opening of the equipment. The max. discharge capacity depends on the orifice size when the ball is completely lifted off its seat and the orifice is fully open.

A manual float-lifting lever is provided so that the equipment can be manually opened (e. g. to purge the seat area or check the position of the float).

Equipment with a SIMPLEX R control unit is fitted with an internal bypass for air venting. Steam, gas or air is continuously discharged through this vent pipe.

Equipment with a DUPLEX control unit provides automatic air venting as a function of the amount of air/gas formed in the steam system. The thermostatic capsule controls the amount of steam that is discharged.

The hand vent valve is an optional extra and allows the equipment to be vented manually.

The equipment can be installed in horizontal or vertical pipelines. A conversion is possible by turning the control unit by 90 °.

Storing and transporting the equipment

Attention!

Equipment can be damaged if stored or transported improperly.

- Close all openings with the sealing plugs or covers supplied with the equipment or use similar sealing covers.
- Protect the equipment against moisture and corrosive atmospheres.
- Please contact the manufacturer if the specified transport and/or storage requirements cannot be met.

Storing the equipment

Please observe the following items when storing the equipment:

- ▶ Do not store the equipment for more than 12 months.
- ▶ Use the supplied sealing plugs or other suitable seal caps in order to seal off all openings of the equipment.
- ▶ Protect the sealing surfaces and contact areas against mechanical damage.
- ▶ Protect the equipment and all components against hard shocks and impacts.
- ▶ Store the equipment only in closed rooms that meet the following environmental conditions:
 - ▶ Air humidity below 50 %, not condensing
 - ▶ Indoor air: clean, salt-free and non-corrosive
 - ▶ Temperature 5–40 °C.
- Make sure that all these requirements are always met when storing the equipment.
- Please contact the manufacturer if you cannot comply with the recommended storage conditions.

Transporting the equipment

- Meet the requirements for storage also when transporting the equipment.
- Prior to transport seal off connections with sealing plugs.



If you do not have the sealing plugs supplied with the equipment use appropriate seal caps to seal off the connections.

- For short distances (only a few metres) you can transport the equipment unpacked.
- When transporting the equipment over larger distances use the original packaging.
- If you do not have the original packaging use a box that protects the equipment adequately against corrosion and physical damage.



For a short period of time the equipment may be transported even if the temperature is below 0 °C, provided that the equipment is completely empty and dry.

Mounting and connecting the equipment

Preparing installation

- Take the equipment out of the transport packaging.
- Check the equipment for transport damage.
- Contact the manufacturer if you detect any kind of shipping damage.

When supplied by the factory, the connections may be sealed off with sealing plugs.

- Remove sealing plugs before mounting the equipment.
- Keep the sealing plugs and the packing for further use.



The equipment can be installed in different positions.

When used as steam trap or float trap for compressed air line drainage the equipment must be installed with the name plate on the cover on top.

When the equipment with a SIMPLEX control unit is to be used for venting gases from liquids the name plate on the cover must be oriented downward. For better air venting capacity in this case equipment with vertical end connection should be used.

Attention!

Malfunctions may occur if the control unit is installed incorrectly.

- When installing the equipment make sure that the name plate is on top and the float is free to move up and down.
- To change the position of installation please follow the instructions given from page 21.



In equipment with SIMPLEX control unit connect a balance line to the optional top connection for the hand vent valve. This is required in particular in the following cases:

- in float traps for compressed air line drainage
- in installations where condensate is lifted upstream of the steam trap.

The balance line improves the condensate flow to the equipment, thereby ensuring the trouble-free operation of equipment with SIMPLEX control unit.

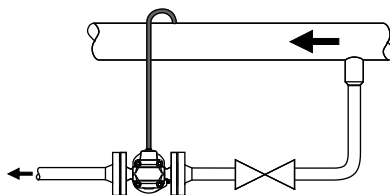

DANGER

Personnel working on pipes are exposed to safety risks and may suffer severe injuries, poisoning or even loss of life.

- Make sure that no hot or hazardous fluid is in the equipment or the pipes.
- Make sure that the pipes upstream and downstream of the equipment are depressurised.
- Make sure that the installation is switched off and protected against unauthorised or unintended activation.
- Make sure that the equipment and the pipes have cooled down to room temperatures.
- Wear protective clothing that is suitable for the fluid and, if necessary, wear protective gear.

For more information on suitable safety clothing and safety gear refer to the safety data sheet of the fluid in question.

- Drain pipes until they are empty.
- Make sure that all pipelines upstream and downstream of the equipment are depressurised.
- Switch the installation off and protect it against unauthorised or unintended re-activation.

Connecting the equipment



DANGER

Incorrectly connected equipment can cause fatal accidents or severe injuries.

- Make sure that only qualified skilled personnel connect the equipment to pipes.
- Make sure that the flow arrow on the equipment body matches the direction of flow in the pipe.

Specialist personnel must be highly qualified and fully experienced in making pipe connections for the respective type of end connection.

Attention!

Equipment will be damaged if the end connections are undersized.

- Make sure that the connections are strong and rigid enough to support the weight of the equipment and to withstand the forces that occur during operation.

To allow easy access for routine servicing and exchanging components observe the indicated withdrawal distance of 120 mm from the cover to adjacent installation parts.

- Make sure that the pipe system of the plant is clean.

- Make sure that the equipment is free from foreign matter.

Attention!

Malfunctions may occur if the equipment is installed incorrectly.

- Equipment that is used for discharging condensate ("liquid drainer") must be installed with the name plate on top.
- Equipment that is used for venting gas or air from liquids ("gas vent") must be installed with the name plate oriented downwards.



You can use equipment with SIMPLEX control unit also for venting gas from liquids.

Note that the line leading to the equipment must be below the equipment. The name plate on the cover must point downwards. When the equipment is used for this purpose it must be installed in inverted position.

When the equipment is used for this purpose very low level leakage will occur.

- Mount the equipment in the desired installation position.
- Make sure that the equipment is safely mounted and that all connections are made correctly.

Operation

Do not work on the equipment while it is operating.

The optional hand vent valve allows manual gas venting.

- To vent gas or air open the hand vent valve.
- Close the hand vent valve fingertight after venting.

The optional float-lifting lever allows the float to be manually lifted irrespective of the liquid level in the trap. It can be used to purge any dirt out of the equipment and away from the seat area by opening the orifice and draining the liquid.

- To open the equipment turn the lever (viewed from body end) anticlockwise.
- To close the equipment turn the float-lifting lever (viewed from body end) clockwise.

After operation



DANGER

If fluid escapes personnel may suffer severe injuries, poisoning or even loss of life.

- After working on the equipment make sure that all connections and valves are tight.
- Make sure that the gaskets of the body are leakproof.



DANGER

If the equipment is used in contaminated areas there is a risk of severe injuries or death caused by harmful substances in or on the equipment.

- Only qualified personnel are allowed to perform work on contaminated equipment.
- Always wear the protective clothing prescribed for contaminated areas when working on the equipment.
- Make sure that the equipment is completely decontaminated before carrying out any service work.
- Follow the pertinent instructions for handling the hazardous substances in question.

Attention!

Frost damage may occur when the installation is shut down.

- Drain the equipment if ambient temperatures below 0 °C (frost) are to be expected.

Removing external dirt deposits

- To remove dirt deposits rinse the equipment with fresh water and wipe it with a clean, lint-free cloth.
- To remove any persistent residues use a cleaning agent that is suitable for the material and carefully wipe the equipment with a clean, lint-free cloth.

Maintaining the equipment

For work on the equipment you will need the following tools:

- ▶ Hexagon socket screw key ("Allen key") size 8, DIN 911L
- ▶ Screwdriver 5.5/125, DIN 5265
- ▶ Punch 120/10, DIN 7250
- ▶ Hammer, 500 g, DIN 1041
- ▶ Torque spanner (US: wrench) 20–120 Nm, DIN ISO 6789

To mount and remove the optional float-lifting lever and the hand vent valve you need the following tools:

- ▶ Combination spanner A. F. 17 mm, DIN 3113, form B



Malfunions may occur if the equipment is used with different types of condensate: The following condensates in particular cause problems:

- ▶ very oily condensates
- ▶ condensates that resinify or become gummy
- ▶ condensates that recrystallize
- ▶ condensates that contain solid matter.

In these cases check the equipment at regular intervals for contamination and, if necessary, remove dirt deposits.

To reduce contamination we recommend installing a sedimentation vessel or a dirt pocket arrangement upstream of the equipment.

Normally you do not have to clean the internal parts of the equipment.

To clean the equipment completely take off the cover and remove the control unit.

Removing cover

- ▶ Undo the four socket-head cap screws of the body.
- ▶ Lift the cover off the body.
- ▶ Remove the gasket.

- ▶ For the disposal of the gasket observe the pertinent on-site regulations concerning waste disposal.

Removing control unit

- ▶ Take the cover off the body as described from page 14 onwards.

Attention!

Malfunions may occur if the mounting support (19) is removed.

- ▶ Do not unscrew the mounting support off the body.
- ▶ Remove the control unit from the mounting support.

The mounting support (19) is firmly attached to the body. You can remove the control unit from the mounting support.

- ▶ Insert a screwdriver (as shown in the drawing) between the control unit (4) and the mounting support (19).
- ▶ To remove the control unit from the mounting bracket hit the screwdriver with a hammer.

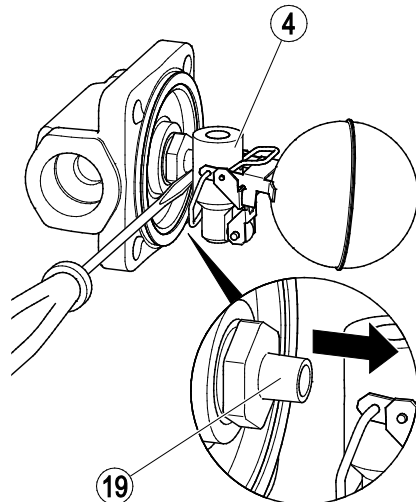

Cleaning the equipment

Check the equipment at regular intervals for contamination. The intervals depend on the amount of dirt in the system. The operator must determine the maintenance intervals.

- To remove dirt deposits rinse the equipment with fresh water and wipe it with a clean, lint-free cloth.
- To remove any persistent residues use a cleaning agent that is suitable for the material and carefully wipe the equipment with a clean, lint-free cloth.
- Remove any parts that are dirty and cannot be cleaned properly.

To clean the inside of the equipment proceed as follows:

- Take the cover off the body as described from page 14 onwards.
- Remove the control unit as described from page 14 onwards.
- To remove dirt deposits rinse the equipment with fresh water and wipe it with a clean, lint-free cloth.
- To remove any persistent residues use a cleaning agent that is suitable for the material and carefully wipe the equipment with a clean, lint-free cloth.
- Attach the control unit to the body as described from page 16 onwards.
- Attach the control unit to the body as described from page 17 onwards.

Cleaning and checking the membrane regulator capsule

To clean the thermostatic capsule of equipment with a DUPLEX control unit proceed as follows:

- Take the cover off the body as described from page 14 onwards.
- Remove the control unit as described from page 14 onwards.
- Attach the control unit to the body as described from page 19 onwards.
- Clean the thermostatic capsule with cold clean water.
- Use a depth gauge to check the dimension x of the membrane regulator capsule as shown in the following drawing.



The membrane regulator capsule is intact if dimension x exceeds 4.0 mm.

- Discard and replace defective membrane regulator capsule with a new one.
- Attach the control unit to the body as described from page 19 onwards.

Mounting the control unit

Attention!

Malfunctions may occur if the control unit is installed incorrectly.

- When installing the equipment make sure that the name plate is on top and the float is free to move up and down.
- Make sure that the flow arrow on the equipment body matches the direction of flow in the pipe.
- Make sure that the control unit is firmly pressed into the mounting support.



If you use equipment with SIMPLEX control unit for venting gas or air from a liquid, make sure that the equipment is installed in inverted position. The name plate on the cover must be oriented downwards.

- Before installation make sure that all component parts are clean.
- Turn the control unit (4) into the desired position of installation.
- Press the control unit into the mounting support.
- Lift the float and hold it in this position.
- Put the punch onto the marking (20).
- Fix the control unit in place by hitting the punch twice with a hammer.

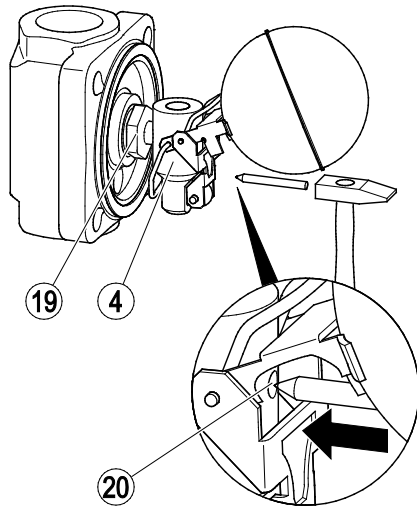

- Attach the control unit to the body as described from page 17 onwards.

Mounting cover

Attention!

Equipment may leak if the gasket is damaged.

- It is therefore essential that you always insert a new gasket before re-attaching the cover.
- Make sure that the cover is not tilted or skewed when refitted.

-
- Clean the gasket surfaces of the cover and body.
 - Apply heat-resistant lubricant (OKS 217) to the threads of the socket-head cap screws and the gasket surface of the cover.
 - Insert a new gasket in the body.
 - Put a new cover onto the body, assuring that the name plate is on top.

Note that the name plate on the cover must be oriented downwards if the equipment with a SIMPLEX control unit is to be used for venting gases from liquids.

- Tighten the four socket-head cap screws evenly in diagonally opposite pairs to a torque of 35 Nm.

Servicing the equipment and installing spare parts

You may exchange the following component parts in case of wear or damage:

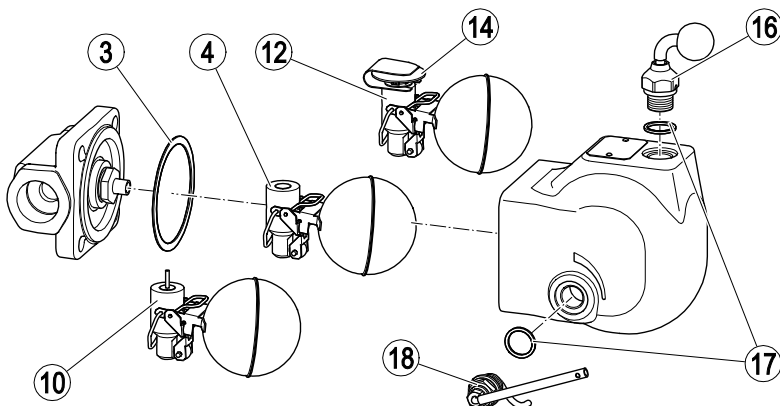

No.	Designation	Stock code #			
		UNA 14	UNA 14P	UNA 16	
3, 4	Control unit SIMPLEX, complete with gasket	Orifice 4	560416	–	560416
		Orifice 13	560415		
		Orifice 16 ¹			
		Orifice 16P ²	–	560418	–
3, 10	Control unit SIMPLEX R, complete with gasket	Orifice 4	560413	–	560413
		Orifice 13	560412	–	560412
		Orifice 22	–	–	560411
3, 12	Control unit DUPLEX, complete with gasket	Orifice 4	560410	–	560410
		Orifice 13	560409	–	560409
		Orifice 22	–	–	560408
3, 14	Thermostatic capsule 5N2, with gasket (graphite/CrNi)	560494	–	560494	
16, 17	Hand vent valve, complete with gasket	560676		560676 ³	
17, 18	Float-lifting lever, complete with gasket	560434		560434 ⁴	
3	Gasket (graphite/CrNi) ⁵	560493			
17	Gasket ⁵	560486		560486 ⁶	

1 Control unit SIMPLEX with rolling ball made from steel for UNA 14P, up to 120 °C to ΔPMX 16 bar

2 Control unit SIMPLEX P with rolling ball made from Perbunan® for UNA 14P, up to 40 °C to ΔPMX 16 bar

3 Stock code number for UNA 16A (stainless steel): 560676

4 Stock code number for UNA 16A (stainless steel): on request

5 Packaged 20 pcs. per box. Contact your local dealer for smaller quantities.

6 Stock code number for UNA 16A (stainless steel): 560514

Packaged 20 pcs. per box. Contact your local dealer for smaller quantities.

Exchanging the control unit

- Take the cover off the body as described from page 14 onwards.
- Remove the control unit as described from page 14 onwards.
- Attach the control unit to the body as described from page 16 onwards.
- Attach the control unit to the body as described from page 17 onwards.

Exchanging the membrane regulator capsule

- Take the cover off the body as described from page 14 onwards.
- Remove the control unit as described from page 14 onwards.
- Pull the bracket (13) sideways off the control unit (1.).
- Push the thermostatic capsule (14) upwards and take it off (2.).

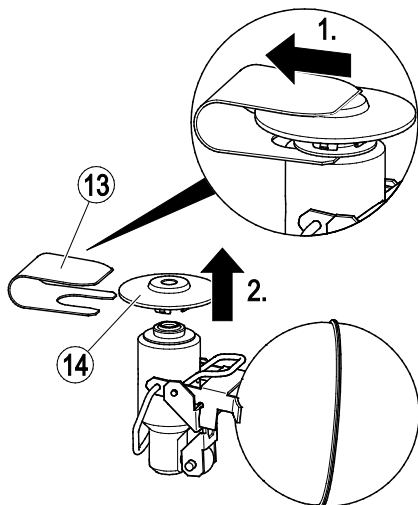

Install a new thermostatic capsule as follows:

- Press the thermostatic capsule (14) onto the seat (21) until it snaps into place.

Slide the tongues of the bracket (13) into the groove underneath the thermostatic capsule.

- Slide the bracket (13) as shown onto the control unit until it snaps into place (2.).
- Rotate the bracket until the two tongues are oriented towards the float.

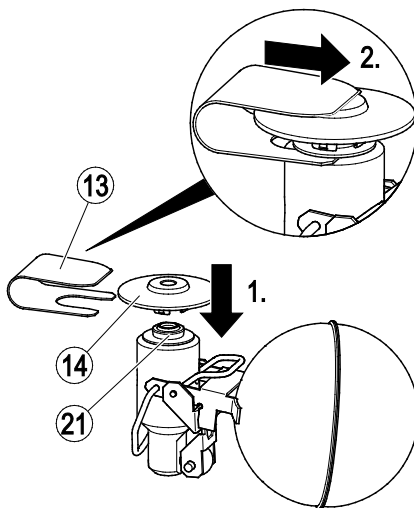

- Attach the control unit to the body as described from page 16 onwards.
- Attach the control unit to the body as described from page 17 onwards.

Exchanging the hand-vent valve



The hand vent valve is an optional extra for all types of equipment.

The hand vent valve can only be installed to equipment with a special cover for fitting such a valve.

- Unscrew the hand vent valve or the sealing plug off the bore.



Danger

Fluid may escape if connections are leaking or sealing rings are damaged.

- Insert a new gasket before re-installation.
 - Use the sealing plug to close the vent hole if you do not mount the hand vent valve.
-
- Insert a new gasket into the bore.
 - Screw the hand vent valve or the sealing plug hand tight into the bore.
 - Tighten the hand vent valve or the sealing plug to a torque of 75 Nm.

Exchanging the float-lifting lever



The float-lifting lever is an optional extra for all types of equipment.

The float-lifting lever can only be installed to equipment with a special cover for fitting such a device.



Danger

Fluid may escape if connections are leaking or sealing rings are damaged.

- Insert a new gasket before re-installation.
 - Use the sealing plug to close the bore if you do not mount the float-lifting lever.
-
- Insert a new gasket into the bore.
 - Screw the float-lifting lever or the sealing plug hand tight into the bore.
 - Tighten the float-lifting lever or the sealing plug to a torque of 75 Nm.

Changing the position of installation



The equipment can be installed in different positions.

When used as steam trap or float trap for compressed air line drainage the equipment must be installed with the name plate on the cover on top.

When the equipment with a SIMPLEX control unit is to be used for venting gases from liquids the name plate on the cover must be oriented downward. For better air venting capacity in this case equipment with vertical end connection should be used.

Attention!

Malfunctions may occur if the control unit is installed incorrectly.

- When installing the equipment make sure that the name plate is on top and the float is free to move up and down.

For this purpose proceed as follows:

- Take the cover off the body as described from page 14 onwards.
- Remove the control unit as described from page 14 onwards.
- Turn the control unit by 90 ° or 180 ° into the desired position of installation.
- Install the control unit such that the float is free to move up and down.

Troubleshooting

Problem	Cause	Remedy
Insufficient condensate discharge. Insufficient thermal output of the user.	The isolating valves for condensate inlet or outlet are closed.	Open the isolating valves.
	The condensate inlet or outlet or the orifice are dirty.	Clean the pipes. If fitted, operate the float-lifting lever. Clean the equipment. Clean the control unit. If necessary, replace the control unit.
	The steam trap is undersized.	Use a steam trap with a larger condensate discharge capacity.
	The differential pressure is too small.	Increase the steam pressure. Lower the pressure in the condensate line. Check the size of the condensate line. Use a steam trap with a larger condensate discharge capacity, a pump steam trap or a condensate return system.
	The condensate line does not have a slight fall from the the drain point towards the steam trap. The condensate is lifted upstream of the steam trap.	Lay the condensate line with a gradient so that the condensate is free to fall towards the equipment. Change the orientation of the condensate line. Connect a balance pipe to the equipment.
	Insufficient deaeration.	Provide additional deaeration.
The steam trap is cold or only hand-hot.	The isolating valves for condensate inlet or outlet are closed.	Open the isolating valves.
	The condensate inlet or outlet or the orifice are dirty.	Clean the pipes. If fitted, operate the float-lifting lever. Clean the equipment.

Problem	Cause	Remedy
The steam trap is blowing off live steam.	There are dirt deposits in the equipment.	If fitted, operate the float-lifting lever. Clean the equipment. Replace the control unit.
	The control unit is worn.	Replace the control unit.
Fluid escapes (equipment is leaking).	The end connections are not tight.	Seal off the end connections (e. g. flanged or screwed ends).
	A gasket on the body is defective.	Replace the gasket with a new one.
	The body has been damaged by corrosion or erosion.	Check the resistance of the material for the fluid used. Use a steam trap made from a material that is suitable for the fluid used.
	The equipment has been damaged by frost.	Replace the equipment with a new one. When shutting down the installation make sure that the condensate lines and the steam trap are completely drained.
	The equipment has been damaged by waterhammer.	Replace the equipment with a new one. Take appropriate measures to protect the equipment against waterhammer, e. g. by installing suitable non-return valves.

- If faults occur that are not listed above or cannot be corrected, please contact our Technical Service or authorized agency in your country.

Putting the equipment out of operation

Removing harmful substances



DANGER

If the equipment is used in contaminated areas there is a risk of severe injuries or death caused by harmful substances in or on the equipment.

- Only qualified personnel are allowed to perform work on contaminated equipment.
- Always wear the protective clothing prescribed for contaminated areas when working on the equipment.
- Make sure that the equipment is completely decontaminated before carrying out any service work.
- Follow the pertinent instructions for handling the hazardous substances in question.

Qualified personnel must have extensive experience with and a working knowledge of:

- ◆ pertinent rules and regulations concerning handling hazardous substances
- ◆ special regulations for handling the hazardous substances encountered on site
- ◆ using the required personal protective equipment (PPE) and clothing

Attention!

Environmental damage may be caused by poisonous fluid residues.

- Before disposing of the equipment make sure that it is clean and free of fluid residues.
 - For the disposal of all materials observe the pertinent legal regulations concerning waste disposal.
-
- Remove all residues from the equipment.
 - For the disposal of all residues observe the pertinent legal regulations concerning waste disposal.

Removing the equipment



DANGER

Personnel working on pipes are exposed to safety risks and may suffer severe injuries, poisoning or even loss of life.

- Make sure that no hot or hazardous fluid is in the equipment or the pipes.
- Make sure that the pipes upstream and downstream of the equipment are depressurised.
- Make sure that the installation is switched off and protected against unauthorised or unintended activation.
- Make sure that the equipment and the pipes have cooled down to room temperatures.
- Wear protective clothing that is suitable for the fluid and, if necessary, wear protective gear.

For more information on suitable safety clothing and safety gear refer to the safety data sheet of the fluid in question.

- Make sure that all pipelines upstream and downstream of the equipment are depressurised.



CAUTION

Danger of bruising if the equipment falls down.

- When removing the equipment make sure the it is safely held in place and cannot fall down.

Suitable measures are for instance:

- ◆ Equipment that is not too heavy may be supported by a second person.
- ◆ For heavy equipment use suitable lifting equipment of sufficient strength.
- Detach the end connections of the equipment from the pipes.
- Put the equipment onto a suitable base.
- Store the equipment as described in section "*Storing the equipment*" on page 10.

Re-using equipment after storage

Observe the following instructions if you want to remove the equipment and use it again somewhere else:

- ◆ Make sure that the equipment is free of any fluid residues.
- ◆ Make sure that all connections are in good condition and leak-free.
- ◆ If necessary re-work welded connections in order to ensure that they are in good working condition.
- Use the equipment only for its intended purpose and the service conditions for which it was specified.

Disposing of the equipment

Attention!

Environmental damage may be caused by poisonous fluid residues.

- Before disposing of the equipment make sure that it is clean and free of fluid residues.
 - For the disposal of all materials observe the pertinent legal regulations concerning waste disposal.
-

The equipment is made from the following materials:

Component	EN number	ASTM
Body UNA 14, UNA 14P, UNA 16	1.0460 (P250GH)	A105
Body UNA 16A (stainless steel)	1.4404 (X2CrNiMo17-12-2)	A182-F316L
Cover UNA 14, UNA 14P	EN-JS-1049 (EN-GJS-400-18-LT)	A536 60-40-18 ¹
Cover UNA 16	1.0619 (GP240GH)	A216-WCB
Cover UNA 16A (stainless steel)	1.4408 (GX5CrNiMo19-11-2)	A351-CF8M
Screws UNA 14, UNA 14P, UNA 16	1.7225 (42CrMo4)	A193-B7
Screws UNA 16A (stainless steel)	1.4980 (X6NiCrTiMoVB25-15-2)	—
Float	1.4571 (X6CrNiMoTi17-12-2)	AISI 316Ti ¹
Orifice	1.4305 (X8CrNiS18-9)	AISI 303 ¹
Rolling ball ²	1.4301 (X5CrNi18-10)	A182-F304 ¹
Gasket (3)	graphite-CrNi	
Thermostatic capsule 5N2	Hastelloy / stainless steel	
Other parts of the control unit, gasket (17)	Stainless steel	

1 Physical and chemical properties comply with DIN grade. ASTM nearest equivalent grade is stated for guidance only.

2 A rolling ball made from Perbunan for UNA 14P is also available.

Technical data

Dimensions and weights

UNA 14 and UNA 14P

		DN 15	DN 20	DN 25
Length L [mm]	Screwed G and NPT	95		
	Flanged to EN 1092-1 and ASME	150		160
Depth (from centre of connection) [mm]	without space required for servicing	156		
	with space required for servicing	276		
Height [mm]		127		
Weight [kg]	Flanges	6.0	6.5	7.0
	Screwed sockets	4.5		
	Socket-weld ends			
	Butt-weld ends (via transition pieces)			

UNA 16 and UNA 16A stainless steel

		DN 15	DN 20	DN 25
Length L [mm]	Screwed sockets	95		
	Flanged to EN 1092-1 and ASME	150		160
	Socket-weld ends	95		
	Butt-weld ends (via transition pieces)	200		
Depth (from centre of connection) [mm]	without space required for servicing	156		
	with space required for servicing	276		
Height [mm]		127		
Weight [kg]	Flanges	6.0	6.5	7.0
	Screwed sockets	4.5		
	Socket-weld ends			
	Butt-weld ends (via transition pieces)			

Pressure & temperature ratings

The max. differential pressure Δ PMX of the equipment depends on the type of orifice used.

Note that the pressure and temperature limits might be further restricted by the type of end connection used.

Orifice	Δ PMX [bar]
4	4
13	13*
22	22

* Equipment fitted with an orifice 13 have a max. differential pressure Δ PMX of 16 bar at a liquid density of $\rho = 1,000 \text{ kg/m}^3$.

Pressure & temperature ratings for UNA 14 made from ductile iron (3 E0), PN25 to EN 1092-1

p (pressure) [bar]	Orifice	25	19.4	17.8	15
T (temperature) [°C]			20	200	250
Max. differential pressure Δ PMX [bar]	Orifice 4	4			
	Orifice 13	13			

Pressure & temperature ratings for UNA 14 P made from ductile iron (3 E0), PN16 to EN 1092-1

	Rolling ball made from steel	Rolling ball made from Perbunan®
p (pressure) [bar]	25	
T (temperature) [°C]	120	40
Max. differential pressure Δ PMX [bar]	16	

Pressure & temperature ratings for UNA 16 made from carbon steel (3 E0), PN40 to EN 1092-1

p (pressure) [bar]	Orifice	40	30.2	25.8	23.1
T (temperature) [°C]			20	200	300
Max. differential pressure Δ PMX [bar]	Orifice 4	4			
	Orifice 13	13			
	Orifice 22	22			

Pressure & temperature ratings for UNA 16 made from carbon steel CLASS 150

p (pressure) [bar]	Orifice	17.3	13.8	10.2	6.5
T (temperature) [°C]			20	200	300
Max. differential pressure Δ PMX [bar]	Orifice 4	4			
	Orifice 13	13			

Pressure & temperature ratings for UNA 16A made from stainless steel (13 E0), PN40 to EN 1092-1

p (pressure) [bar]	Orifice	40	35.6	29.3	25.8
T (temperature) [°C]		20	100	200	300
Min. temperature up to PN [°C]		-196			
Max. differential pressure Δ PMX [bar]	Orifice 4	4			
	Orifice 13	13			
	Orifice 22	22			

Pressure & temperature ratings for UNA 16A made from stainless steel CLASS 150, flanged

p (pressure) [bar]	Orifice	19.3	17.0	14.0	10.2
T (temperature) [°C]		20	100	200	300
Min. temperature up to PN [°C]		-196			
Max. differential pressure Δ PMX [bar]	Orifice 4	4			
	Orifice 13	13			
	Orifice 22	22			

For the flowrate as a function of the differential pressure see the capacity chart in the data sheet. Equipment with a DUPLEX control unit has a higher flowrate during start-up with cold water. The corresponding values are indicated in the data sheet.

Manufacturer's declaration

For more information on the Conformity Assessment according to European rules refer to our Declaration of Conformity or our Declaration by Manufacturer.

To download the current Declaration of Conformity or Declaration by Manufacturer go to www.gestra.com/documents or contact:

GESTRA AG

Münchener Straße 77

28215 Bremen

Germany

Telefon +49 421 3503-0

Telefax +49 421 3503-393

E-Mail info@de.gestra.com

Web www.gestra.de

This declaration is no longer valid if modifications are made to the equipment without consultation with us.



Agencies all over the world: www.gestra.de

GESTRA AG

Münchener Strasse 77

28215 Bremen

Germany

Phone +49 421 3503-0

Fax +49 421 3503-393

e-mail info@de.gestra.com

Web www.gestra.com

810877-05/09-2017 kx_mm (808563-04) © GESTRA AG Bremen Printed in Germany