

UNA 47 v, DN 25

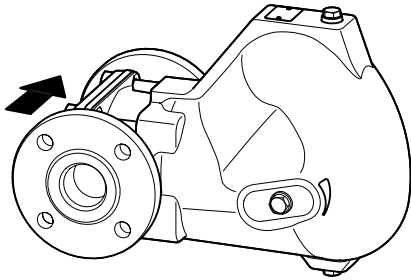
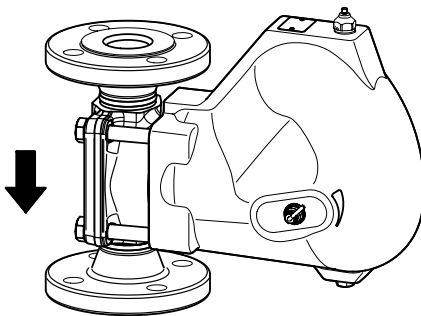

UNA 47 hi, DN 50

 UNA 47 v MAX, DN 50
with manual vent valve and manual lifting lever

Ball Float Steam Trap

UNA 47, DN 15, 20, 25, 40, 50
UNA 47 MAX, DN 40, 50
PN 63

Description

Type UNA 47 and UNA 47 MAX ball float steam traps are used to discharge condensate from steam or other gases or gaseous mixtures.

Models with SIMPLEX control unit are particularly suited to cold condensates, cold distillates and superheated steam.

UNA 47 with SIMPLEX control unit are controlled by the float with rolling ball regulator.

UNA 47 MAX with SIMPLEX control unit are controlled by the float with pilot valve and bellows.

Models with DUPLEX control unit also vent the system. This control unit is especially suitable for steam systems.

UNA 47 with DUPLEX control unit have an additional temperature-dependent bimetallic vent, and are also suitable for superheated steam.

UNA 47 MAX with DUPLEX control unit have an additional temperature-dependent vent with membrane regulator capsule. In these models, the overheating of the steam on the membrane regulator capsule must not exceed 5 K.

The cover has four holes.

You can lift the ball float manually using the optional manual lifting lever.

The optional manual vent valve allows you to vent the equipment and pipe manually.

The equipment may only be used within the admissible pressure and temperature ratings, with due consideration of chemical and corrosive influences.

Fluids

The equipment is designed for the following fluids, in accordance with the EU Pressure Equipment Directive (Pressure Equipment (Safety) Regulations in the UK):

UNA 47, UNA 47 MAX

Fluid group 1

Fluid group 2

Due consideration must be given to chemical and corrosive influences.

Potentially explosive atmospheres

The equipment does not have its own potential source of ignition (as per ATEX Directive). Please note the following information:

Once installed, static electricity may arise between the equipment and the connected system.

If used in potentially explosive atmospheres, the plant manufacturer or owner is responsible for discharging or preventing possible static charge.

If there is a possibility of fluid escaping, e.g. via actuating devices or leaks in threaded connections, the manufacturer or owner of the system must take this into consideration when classifying potentially explosive zones.

Optional equipment

- Manual lifting lever for manually lifting the ball float
- Manual vent valve for manually venting the steam trap and pipe (standard for SIMPLEX version)
- Flow runs horizontally to the right (hr)

Function

The control unit opens the orifice based on the fill level. This regulates the drainage rate. With the orifice opened to maximum, the drainage rate depends on the diameter of the orifice.

Thanks to the different versions available, you can adapt the equipment's direction of flow to suit your plant. The following installation positions are possible:

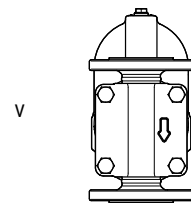

Position "v" for installation in vertical pipes with downward direction of flow

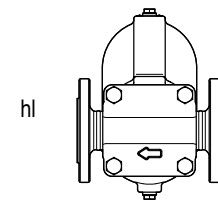

Position "hl" for direction of flow to the left

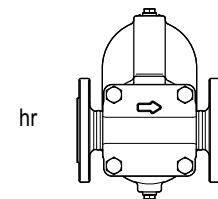

Position "hr" for direction of flow to the right

Connections

- Flange EN 1092-1, B2, PN 63
- Flange ASME B 16.5 Class 400/(600) RF
- Socket-weld end DIN EN 12760
- Butt-weld end via transition pieces EN 12627, welded joint geometry ISO 9692-1 code no. 1.3 (30° chamfer)
- Butt-weld end via transition pieces ASME B 16.25, ASME B 36.10

Materials

Component	EN
Body	1.5415
Cover of UNA 47	1.5419
Cover of UNA 47 MAX	1.7357
Body gasket	Graphite CrNi
Bolts	1.7225

Pressure and temperature ratings of UNA 47: Flange PN 63, socket-weld end, butt-weld end via transition pieces

Pressure ¹⁾ p	[barg]	63	61.5	54	51	47.1	45.3	43.5
Temperature ¹⁾ T	[°C]	-10/200	250	300	350	400	425	450
Maximum admissible differential pressure Δ PMX	[bar]	16, 28, 45						

¹⁾ Limit ratings for strength of body/cover to EN 1092-1

Structural diagram of UNA 47

UNA 47 SIMPLEX version

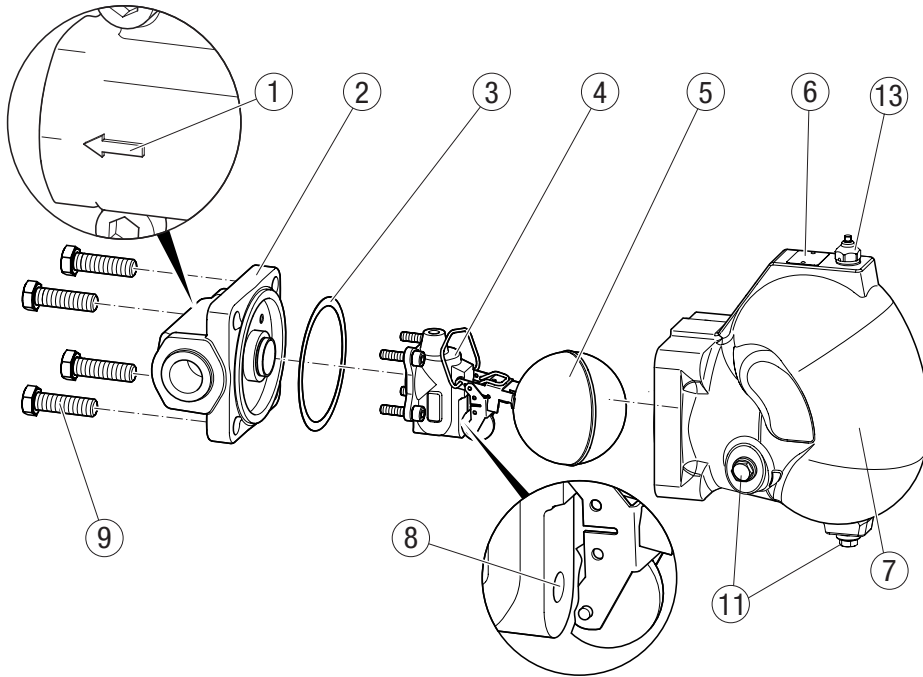

UNA 47 DUPLEX version

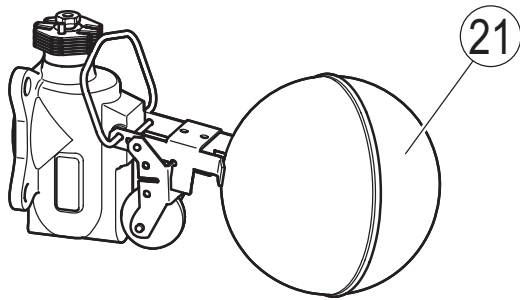

Optional equipment

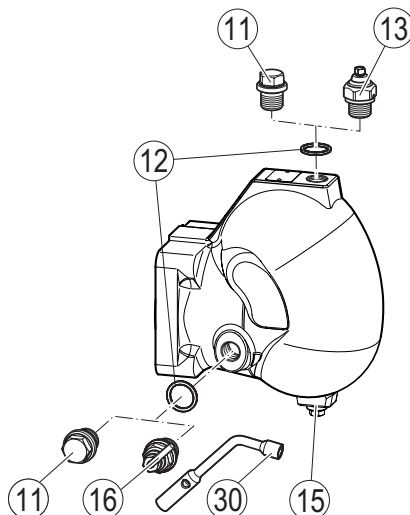

The maximum differential pressure Δ PMX of the equipment depends on the orifice used.

Orifice	Δ PMX [bar]	Hole diameter [mm]
16	16	8.5
28	28	7.0
45	45	6.5

UNA 47 SIMPLEX version

No.	Designation
1	Direction of flow arrow
2	Body
3	Body gasket
4	SIMPLEX control unit
5	Ball float
6	Name plate
7	Cover
8	Orifice
9	Bolts (4x)
11	Sealing plug
13	Manual vent valve (optional with DUPLEX version)

UNA 47 DUPLEX version

No.	Designation
21	DUPLEX control unit

Optional equipment

No.	Designation
11	Sealing plug
12	Sealing ring
13	Manual vent valve with socket wrench The hole in the cover for the manual vent valve can also be used to connect an air balance pipe.
15	Drain with sealing plug
16	Manual lifting lever with socket wrench
30	Socket wrench

By way of example, the diagram below shows a unit with standard cover and flanged end for a downward flow.

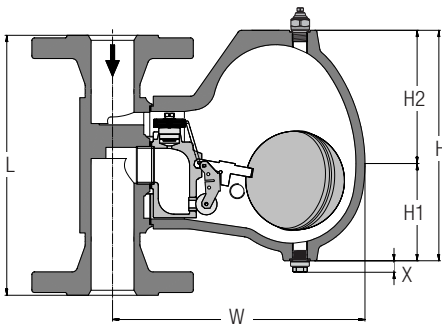

UNA 47
DUPLEX control unit with bimetallic regulator

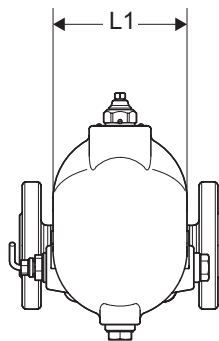

Horizontal installation

Dimensions and weights

UNA 47

Nominal size	DN 15 (½")	DN 20 (¾")	DN 25 (1")	DN 40 (1½")	DN 50 (2")
W [mm (in)]	290 (11.5)				
H1 [mm (in)]	110 (4.4)				
H2 [mm (in)]	155 (6.2) 1)				
H [mm (in)]	260 (10.3) 1)				
L1 [mm (in)]	175 (6.8) 2)				
X [mm (in)]	13 (0.5)				

1) Plus 25 mm if fitted with manual vent valve.

2) Plus 35 mm if fitted with manual lifting lever.

UNA 47 with flange EN 1092-1, B2, PN 63

Nominal size	DN 15 (½")	DN 20 (¾")	DN 25 (1")	DN 40 (1½")	DN 50 (2")
Length L [mm (in)]	230 (9.1)	260 (10.3)		290 (11.5)	
Weight [kg]	26	28	29	33	34
Weight [lb]	57.3	61.7	64.0	63.9	75.0

UNA 47 with flange ASME B16.5 Class 400/(600)

Nominal size	DN 15 (½")	DN 20 (¾")	DN 25 (1")	DN 40 (1½")	DN 50 (2")
Length L [mm (in)]	241 (9.5)	267 (10.5)		292 (11.5)	
Weight [kg]	25	26	27	32	34
Weight [lb]	55.1	57.3	59.5	70.5	75.0

Non-standard length: UNA 47hl replaces UNA 27h with flange EN 1092-1, B2, PN 63

Nominal size	DN 25 (1")	DN 40 (1½")	DN 50 (2")
Length L [mm]	300	420	416
Weight [kg]	29	35	37

UNA 47 DN15 to DN40 with socket-weld end, UNA 47 DN50 with socket-weld end via transition pieces

Nominal size	DN 15 (½")	DN 20 (¾")	DN 25 (1")	DN 40 (1½")	DN 50 (2")
Length L [mm (in)]	165 (6.5) (Socket-weld end)				290 (11.4) (Socket-weld end via transition pieces EN, ASME)
Weight [kg]	24	23	25	27	
Weight [lb]	52.9	50.7	55.1	59.5	

Service dimensions

A service dimension S of 240 mm is required for removing the cover.

Models with fitted socket wrench require an additional distance of 100 mm.

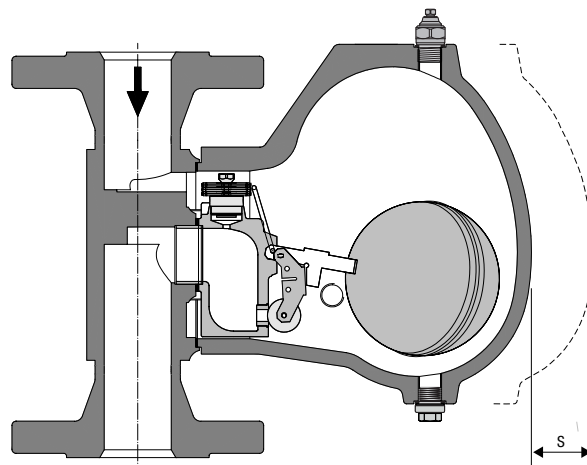

Pressure and temperature ratings of UNA 47 MAX: Flange PN 63, (butt)/socket-weld end, butt-weld end via transition pieces

Pressure ¹⁾ p	[barg]	63	61.5	54	51	47.1	45.3	43.5
Temperature ¹⁾ T	[°C]	-10/200	250	300	350	400	425	450
Maximum admissible differential pressure Δ PMX	[bar]	4, 8, 13, 22, 32						

¹⁾ Limit ratings for strength of body/cover to EN 1092-1

Models with DUPLEX control unit with membrane regulator capsule: The maximum operating temperature is equal to the saturated steam temperature +5 K.

Structural diagram of UNA 47 MAX

UNA 47 MAX DUPLEX version

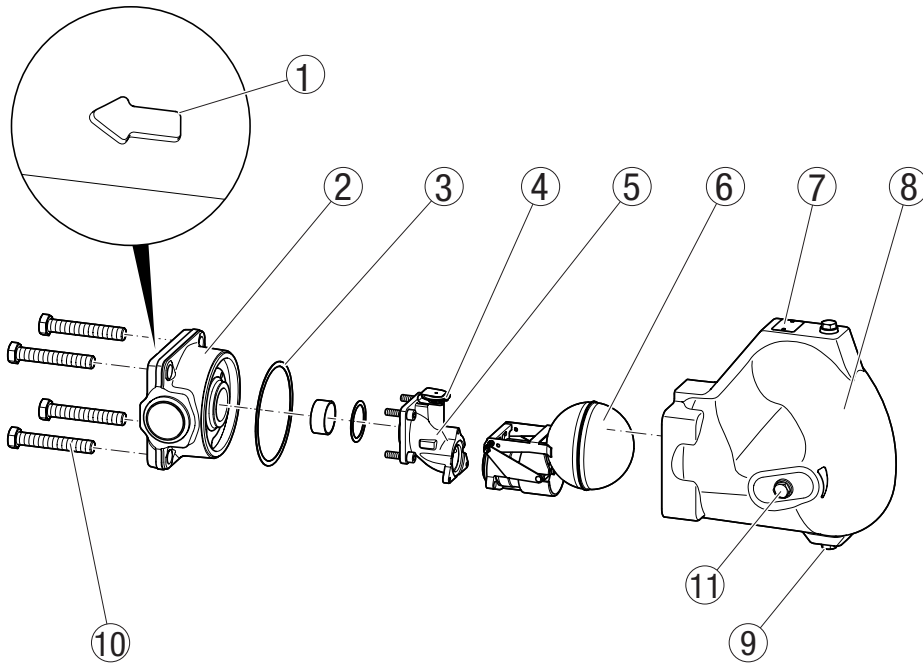

UNA 47 MAX SIMPLEX version

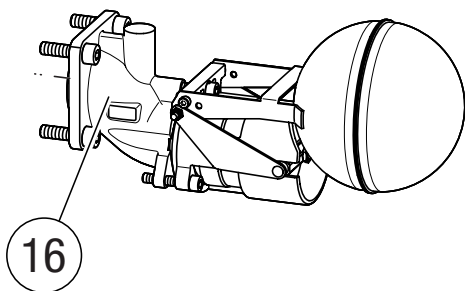

Optional equipment

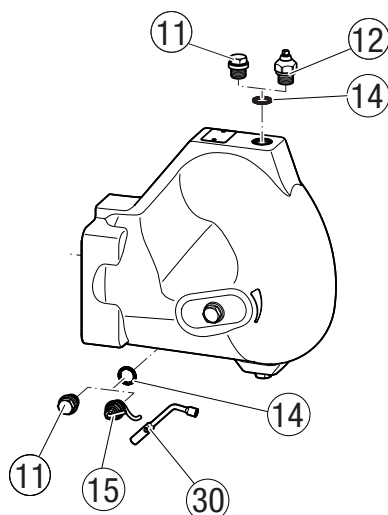

The maximum differential pressure Δ PMX of the equipment depends on the orifice used.

Orifice	Δ PMX [bar]	Hole diameter [mm]
4	4	27.5
8	8	19.4
13	13	15.3
22	22	11.7
32	32	9.7

UNA 47 DUPLEX version

No.	Designation
1	Direction of flow arrow
2	Body
3	Body gasket
4	Membrane holder with membrane regulator capsule
5	Adapter with DUPLEX control unit
6	Membrane regulator capsule
7	Name plate
8	Cover with 4 holes
9	Drain with sealing plug
10	Hexagon head bolts (4x)
11	Sealing plug

UNA 47 SIMPLEX version

No.	Designation
16	Adapter with SIMPLEX control unit

Optional equipment

No.	Designation
12	Manual vent valve with socket wrench The hole in the cover for the manual vent valve can also be used to connect an air balance pipe.
14	Sealing ring
15	Manual lifting lever with socket wrench
30	Socket wrench

By way of example, the diagram below shows a unit with standard cover and flanged end for a downward flow.

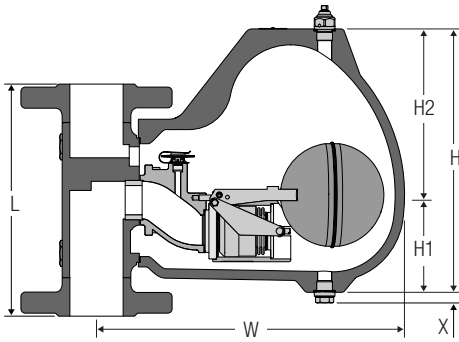

UNA 47 MAX
DUPLEX control unit
Version with flange

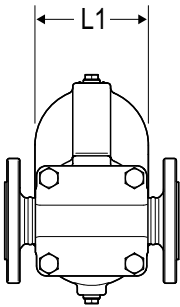

Horizontal installation

Dimensions and weights

UNA 47 MAX

Nominal size	DN 40 (1½")	DN 50 (2")
W [mm (in)]	328 (12.9)	
H1 [mm (in)]	98 (3.9)	
H2 [mm (in)]	182 (7.2) ¹⁾	
H [mm (in)]	280 (11.0) ¹⁾	
L1 [mm (in)]	160 (6.3) ²⁾	
X [mm (in)]	13 (0.5)	

¹⁾ Plus 25 mm if fitted with manual vent valve.

²⁾ Plus 35 mm if fitted with manual lifting lever.

UNA 47 MAX DN 40/DN 50 flange EN 1092-1 PN 63

Nominal size	DN 40 (1½")	DN 50 (2")
Length L [mm (in)]	290 (11.4)	
Weight [kg]	41.0	42.0
Weight [lb]	90.5	92.5

UNA 47 with flange ASME B16.5 Class 400/(600)

Nominal size	DN 40 (1½")	DN 50 (2")
Length L [mm (in)]	241 (9.5)	267 (10.5)
Weight [kg]	39.0	41.0
Weight [lb]	86.0	90.5

UNA 47 MAX DN 40 with socket-weld end, DN 50 with socket-weld end via transition pieces

Nominal size	DN 40 (1½")	DN 50 (2")
Length L [mm (in)]	165 (6.5)	290 (11.4)
Weight [kg]	25.0	34.0
Weight [lb]	55.1	75.0

UNA 47 MAX with butt-weld end via transition pieces

Nominal size	DN 40 (1½")	DN 50 (2")
Length L [mm (in)]	292 (11.5)	
Weight [kg]	32.0	34.0
Weight [lb]	70.5	75.0

Service dimensions

A service dimension S of 270 mm is required for removing the cover.

Models with fitted socket wrench require an additional distance of 100 mm.

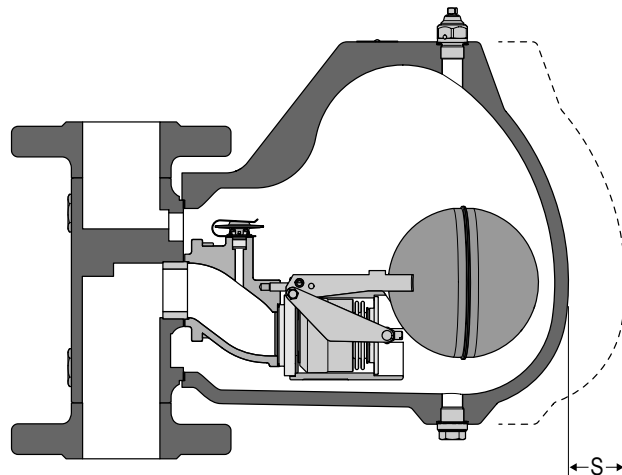

Ball Float Steam Trap
UNA 47
UNA 47 MAX
PN 63/Class 400/(600)

Capacity chart

The chart shows the maximum flowrates of hot condensate at the orifices.

The differential pressure (service pressure) influences the flowrates.

It is the result of the pressure upstream of the steam trap minus the pressure downstream of the trap, and is dependent on the line routing, among other things. If the condensate is lifted downstream of the steam trap, the differential pressure is reduced by practically 1 bar per 7 m of discharge head.

The maximum admissible differential pressure depends on the discharge cross section of the orifice and the density of the discharging fluid.

UNA 47 and UNA 47 MAX steam traps discharge the hot condensate volumes stated here with virtually no banking up.

The cold water capacity for UNA 47 steam traps with SIMPLEX or DUPLEX control unit equals: flowrate multiplied by factor F.

Acceptance tests

An inspection certificate to EN 10204 can be provided as verification of material and construction tests. All inspection requirements must be stated in the request for a quote or in the order. Inspection certificates can no longer be issued once delivery has been made. The standard test scope and costs of the above-mentioned test certificates can be found in our price list "Test and Inspection Charges for Standard Equipment". If you require a different inspection scope, please request a separate quote.

Directives and standards

You can find details on the conformity of the equipment and the applicable standards and directives in our Declaration of Conformity and the relevant certificates or approvals.

Please note our general terms of business.

Capacity chart of UNA 47

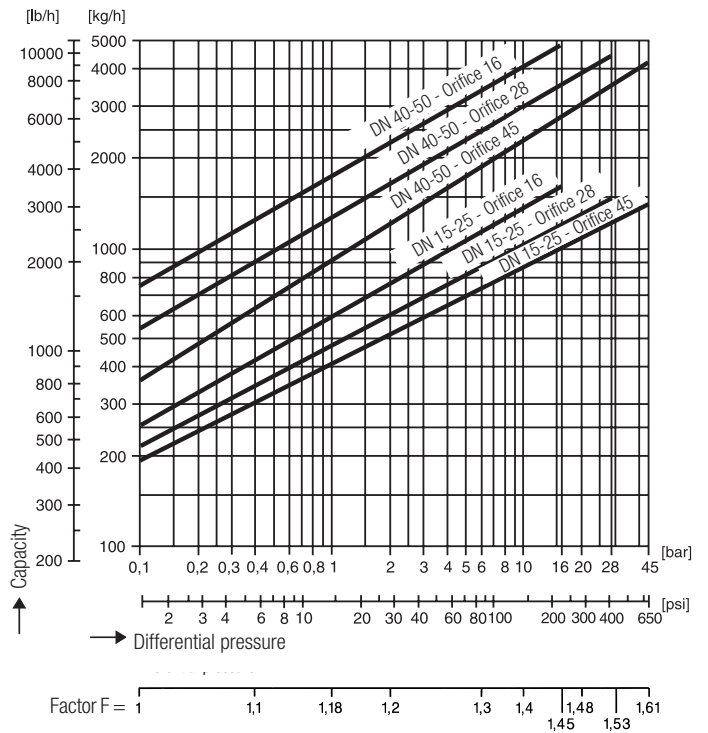

Capacity chart of UNA 47 MAX with hot condensate

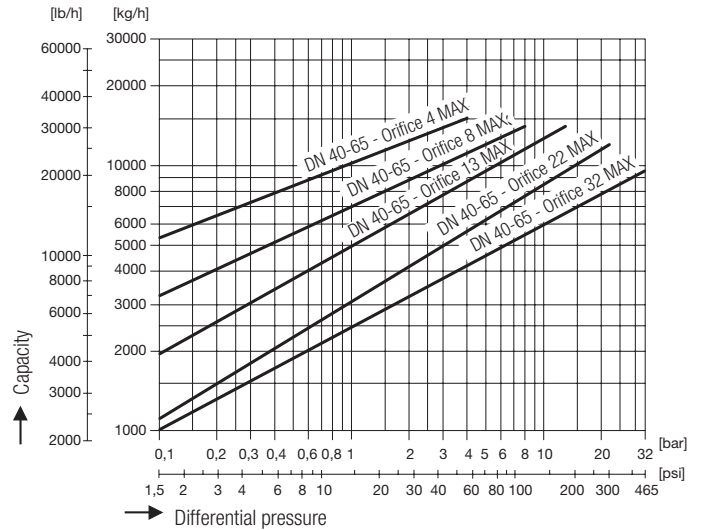

Capacity chart of UNA 47 MAX with cold water

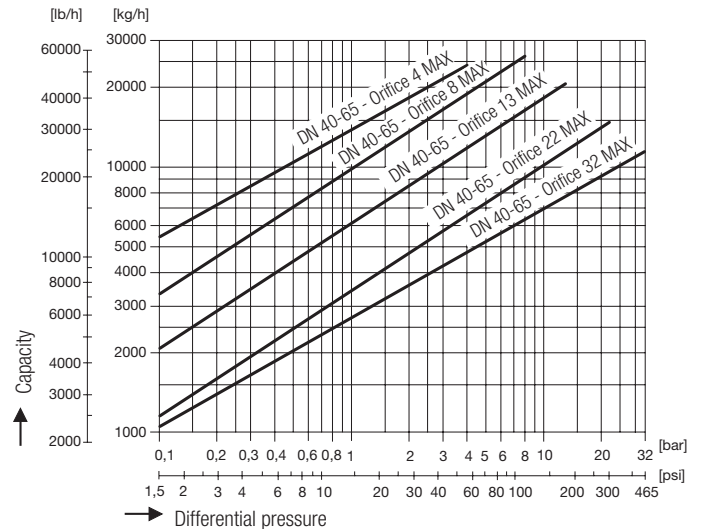

GESTRA AG

Münchener Straße 77, 28215 Bremen, Germany
 Tel. +49 421 3503-0, Fax +49 421 3503-393
 e-mail info@de.gestra.com, website www.gestra.com

