



Gas cooler series EGK 4S

In the chemical industry, petrochemistry or biochemistry, reliable process control relies on prompt and exact determination of the operating parameters.

Here, gas analysis is the key for safe and efficient control of process flows, environmental protection and quality assurance. This benefits controlling flue gas emission in power stations or exhaust gas analysis in automotive engineering, as well as the efficient control of air separators or sterile production and packaging in the food industry.

Many of the analysis processes used in these fields require extracting the sample gas. This inevitably also extracts process-related contamination such as particles or moisture. These in turn can impact the measurement results or damage the measuring cells. The sample gas must therefore be conditioned before entering the analyser.

The EGK 4S is a compressor sample gas cooler for up to 8 separate gas paths and is an essential component in sophisticated analysis systems.

19" rack, wall-mounting or tabletop use

Compact size

Up to 4 stainless steel, glass or PVDF heat exchangers per unit, up to 8 gas paths available upon request

Electronic control with cooling block temperature display

Self-monitoring with contact output $\pm 3\text{ }^{\circ}\text{C}$

Rated cooling power 800 kJ/h

Dew point stability $0.1\text{ }^{\circ}\text{C}$

CFC-free



Performance Data

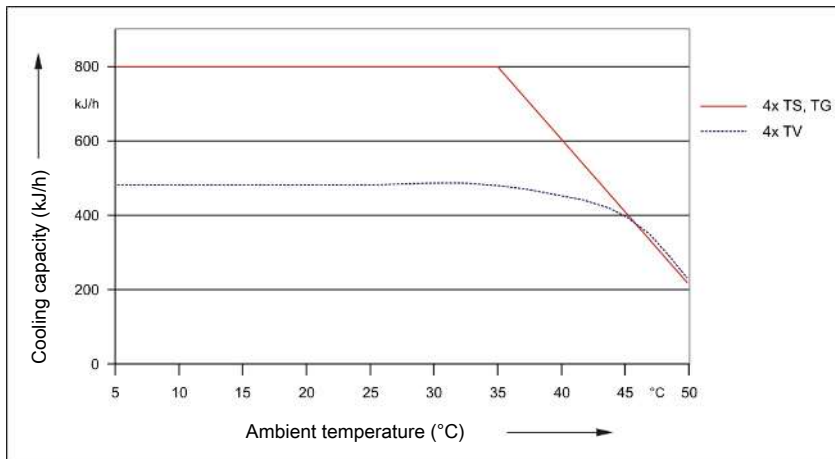

Note: The limit curves for the heat exchangers exchanger apply to a dew point of 65 °C.

Technical Data

Gas Cooler Technical Data

Ready for operation	after max. 15 minutes	
Rated cooling capacity (at 25 °C)	800 kJ/h	
Ambient temperature	5 °C to 50 °C	
Gas output dew temperature, preset:	5 °C	
Dew point fluctuations		
static:	± 0.2 K	
in the entire specification range:	± 2 °C	
IP rating	IP 20	
Housing	Stainless steel	
Packaging dimensions	approx. 510 x 355 x 450 mm	
Weight incl. 4 heat exchangers	max. 32 kg	
Electric supply	115 V, 60 Hz or 230 V, 50 Hz	
Status output switching capacity	250 VAC/ 150 VDC Changeover contact 2 A, 30 VA	
Electrical data	230 V	115 V
	Typical power input:	240 VA 215 VA
	max. operating current:	2.5 A 4.6 A
Starting current	10 A	
Status output switching capacity	250 VAC/ 150 VDC Changeover contact 2 A, 30 VA	

Diagram typical installation

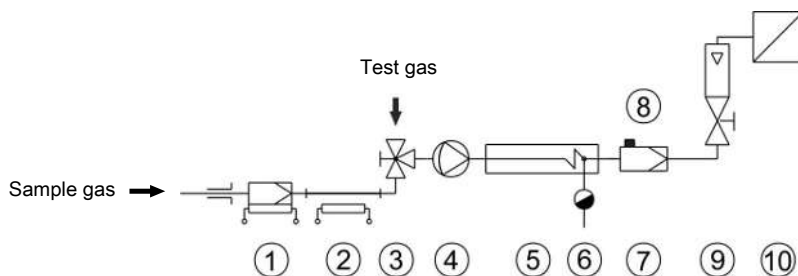

1 Sample gas probe	2 Sample gas line
3 Reversing tap	4 Sample gas pump
5 Sample gas cooler	6 Automatic condensate drain
7 Fine mesh filter	8 Moisture detector
9 Flow meter	10 Analyser

See data sheets for individual component models and data.

Heat exchanger description

The energy content of the sample gas and the required cooling capacity of the gas cooler is determined by three parameters: gas temperature ϑ_G , (inlet) dew point τ_e (moisture content) and volume flow v . The outlet dew point rises with increasing energy content of the gas. The approved energy load from the gas is therefore determined by the tolerated rise in the dew point.

The following limits are specified for a normal standard operating point of $\tau_e = 65^\circ\text{C}$ and $\vartheta_G = 90^\circ\text{C}$. The maximum volume flow v_{max} in NI/h of cooled air is indicated, so after moisture has condensed.

If the values fall below τ_e and ϑ_G , the flow v_{max} may be increased. For example, on the TG heat exchanger the parameter triple $\tau_e = 65^\circ\text{C}$, $\vartheta_G = 90^\circ\text{C}$ and $v = 280\text{ NI/h}$ may also be used in place of $\tau_e = 50^\circ\text{C}$, $\vartheta_G = 80^\circ\text{C}$ and $v = 380\text{ NI/h}$

Please contact our experts for clarification or refer to our design program.

Heat exchanger overview

Heat exchanger	TS TS-I ²⁾	TG TG	TV TV-I ²⁾
Version / Material	Stainless steel	Glass	PVDF
Flow v_{max} ¹⁾	530 L/h	280 L/h	150 L/h
Inlet dew point $\tau_{e,\text{max}}$ ¹⁾	80 °C	80 °C	65 °C
Gas inlet temperature $\vartheta_{G,\text{max}}$ ¹⁾	180 °C	140 °C	140 °C
Max. Cooling capacity Q_{max}	450 kJ/h	230 kJ/h	120 kJ/h
Gas pressure p_{max}	160 bar	3 bar	3 bar
Pressure drop Δp ($v=150\text{ L/h}$)	8 mbar	8 mbar	8 mbar
Dead volume V_{tot}	69 ml	48 ml	129 ml
Gas connections (metric)	G1/4	GL 14 (6 mm) ³⁾	DN 4/6
Gas connections (US)	NPT 1/4"	GL 14 (1/4") ³⁾	1/4"-1/6"
Condensate out connections (metric)	G3/8	GL 25 (12 mm) ³⁾	G3/8
Condensate out connections (US)	NPT 3/8"	GL 25 (1/2") ³⁾	NPT 3/8"

¹⁾ Max. cooling capacity of the cooler must be considered

²⁾ Models marked I have NPT threads or US tubes, respectively.

³⁾ Gasket inside diameter

Dimensions (mm)

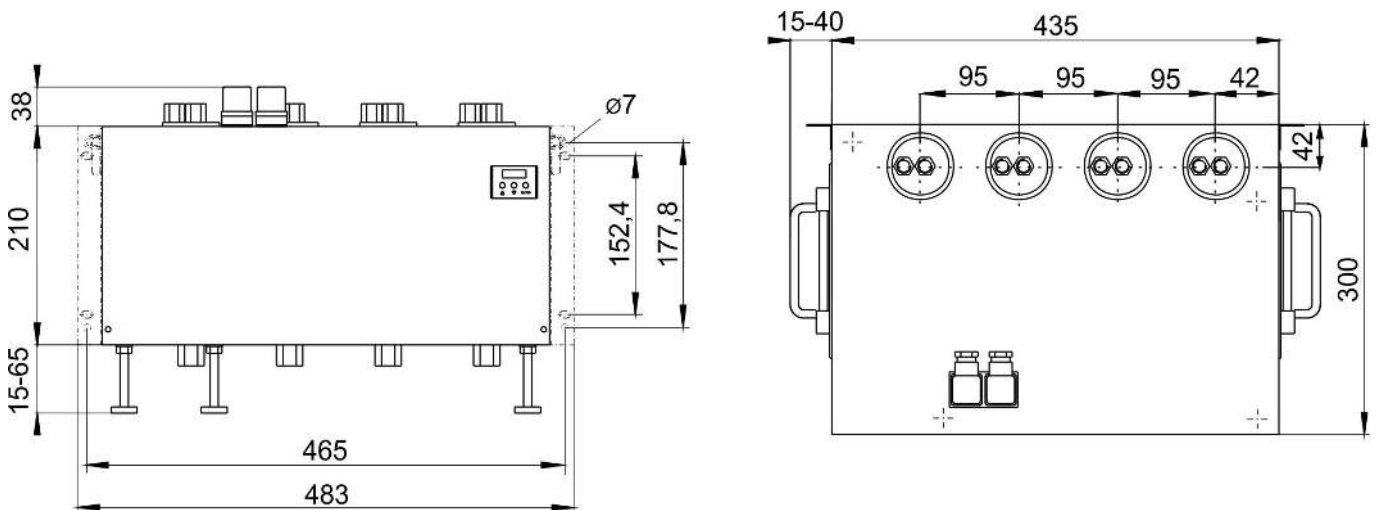

Ordering instructions

The item number is a code for the configuration of your unit. Please use the following model key:

457	X	X	X	X	X	0	0	0	X	Product Characteristics
										Gas cooler models
	0									Wall mounting
	1									19" rack installation
										Supply voltage
		1								115 V metric screw connections
		2								230 V metric screw connections
		3								115 V US screw connections
		4								230 V US screw connections
										Gas paths ¹⁾
		0								without heat exchanger
		1								1 gas path
		2								2 gas paths
		3								3 gas paths
		4								4 gas paths
										Heat exchanger
		0	0							without heat exchanger
		1	0							Single stainless steel heat exchanger/ (TS or TS-I)
		2	0							Single glass heat exchanger/ (TG)
		3	0							Single PVDF heat exchanger/ (TV or TV-I)
										Condensate drain ²⁾
			0							without condensate drain
										Mounting Accessories
									0	without mounting accessories
									1	with mounting brackets
									2	with feet
									3	with mounting brackets and feet
									4	with handles
									5	with mounting brackets and handles
									6	with feet and handles
									7	with all mounting accessories

¹⁾ up to 8 gas paths upon request.

²⁾ Peristaltic pumps must be installed separately or can be mounted to the cooler using a mounting angle. The supply voltage corresponds with that of the main unit. Automatic condensate drains are installed separately.

Spare Parts and Accessories

Item no.	Description
44 10 00 1	Automatic condensate drain 11 LD V 38
44 10 00 4	Automatic condensate drain AK 20, PVDF
44 10 00 5	Condensate trap GL 1; glass, 0.4 L
44 10 01 9	Condensate trap GL 2; glass, 1 L
see data sheet 450020	Peristaltic Pump CPsingle, CPdouble
45 70 00 8	Mounting angles for up to 4 peristaltic pumps