

Operating and maintenance manual
Control valve ECOTROL®
Series 8C

Original instructions

© ARCA Regler GmbH. All rights reserved.

Cover picture background: Freepik.com

Table of contents

1	General data	5
1.1	Validity of the manual	5
1.2	Contact details.....	5
1.3	Other applicable documents.....	5
1.4	Place of storage of the manual.....	5
1.5	ARCA ONSITE	5
2	Safety	7
2.1	General safety information	7
2.2	Explanation of symbols and notices	7
2.3	Structure of the warning notices	7
2.4	Intended use.....	8
2.5	Inappropriate use	9
2.6	Residual risks	9
2.7	Qualification of the personnel.....	9
2.8	Operator's duty of care	10
2.9	Personal protective equipment.....	11
3	Transport, storage and packaging	12
3.1	Transport	12
3.2	Storage	12
3.3	Packaging.....	12
4	Nameplate	13
5	Type key	14
6	Sectional drawings	15
6.1	Parts list.....	15
6.2	8C1-P1	17
6.3	8C1-P1	17
6.4	8C1-L1-LK1	18
6.5	8C1-P1-BG.....	18
6.6	8C3-L1.....	19
6.7	8C4-P1	20
6.8	8C5-P1 to -50 °C	21
6.9	8C7-P1	22
7	Functional description	23
8	Fitting	24
9	Commissioning / Decommissioning	26
10	Maintenance	28
10.1	Care.....	28
10.2	Maintenance	28

10.3	Stem seal – Detail X.....	28
10.3.1	V-collars	29
10.3.2	Packing rings.....	30
10.3.3	Shaped ring	30
11	Disassembly / assembly of the valve	31
11.1	Procedure.....	31
11.2	Actuator	31
11.3	Bonnet.....	31
11.4	Stem sealing.....	32
11.5	Plain bearing	32
11.6	Intermediate flange (version with bellows)	32
11.7	Cylinder tube (version with balancing system).....	33
11.8	Plug	33
11.9	Stem	33
11.10	Balancing seal - Detail Z (version with balancing system)	35
11.11	Retainer & seat.....	36
12	Torque tables - bolted connections.....	38
12.1	Screws according to DIN EN ISO 4017/4014, DIN 939	38
12.2	Screws according to DIN 2510	38
12.3	Screws according to ASME B16.5	38
12.4	Hex nut (57).....	38
13	Fault removal	40
14	Disposal and recycling	41

1 General data

This operating manual contains instructions that enable the product to be safely and properly installed, put into operation and maintained.

The target group for this operating manual is exclusively specially trained and authorised technical personnel.

Please contact the manufacturer if you encounter problems that cannot be solved with the aid of this operating manual.

The product is subject to technical changes at any time.

1.1 Validity of the manual

This operating manual applies to the product in the version described in the device pass.

1.2 Contact details

Further information about the product can be obtained from:

Manufacturer's address

ARCA Regler GmbH
Kempener Str. 18
D-47918 Tönisvorst
Tel.: +49 (0) 2156-7709-0
Fax: +49 (0) 2156-7709-55
E-mail: sale@arca-valve.com
www.arca-valve.com

1.3 Other applicable documents

The product can be delivered as part of an actuator and equipped with additional components that are described in their own operating manuals. The instructions as well as the warning and safety information contained therein must also be observed.

Furthermore, the following documents apply in addition to this operating manual.

- Device pass
- Installation drawing

1.4 Place of storage of the manual

The operating manual and all other applicable documents are part of the product. They must be kept in the immediate vicinity of the product and must be accessible to the personnel at all times.

1.5 ARCA ONSITE

Acceptance documents (if ordered) and operating documentation for this product can be downloaded from the ARCA ONSITE portal.

Two options are available here:

1. Scan the **QR Code**¹ on the product. Further entries are not required.

2. Visit the website <https://onsite.arca-valve.com/search> and enter the ARCA order no. and ARCA serial no. The order no. and serial no. can be found in the device pass and in our order confirmation.

Entry example

2512345	1234567
---------	---------

Search	Clear
--------	-------

[← back / zurück](#)

Illustration 1: ARCA ONSITE

¹ **QR Code** is a registered trademark of DENSO WAVE INCORPORATED

2 Safety

2.1 General safety information

The operating manual contains detailed descriptions for the safe installation, commissioning and maintenance of the product.

- Read this operating manual attentively in its entirety in order to familiarise yourself with the product.
- Particular attention must be paid to the information in this chapter.

2.2 Explanation of symbols and notices

Safety and warning instructions are intended to avoid hazards to the life or health of operating or maintenance personnel, and to avoid material damage. It is emphasised through the use of the special terms defined here. Additionally, their location is marked by warning symbols (pictograms). The signal terms used have the following meanings:



DANGER

means that death, serious injuries and/or considerable damage to property will occur if the corresponding preventive measures are not taken and maintained.



WARNING

means that death, serious injuries and/or considerable damage to property can occur if the corresponding preventive measures are not taken and maintained.



CAUTION

means that minor injuries and/or damage to property can occur if the corresponding preventive measures are not taken and maintained.



NOTICE

indicates an important item of information about the product itself or how the product should be handled, to which special attention should be paid.

2.3 Structure of the warning notices

Section-related warning notice

Section-related warning notices refer to the entire chapter, sections or several paragraphs within this operating manual. Section-related warning notices are structured as follows:



⚠ DANGER

Type and source of the danger

Possible consequences of disregard

- ▶ Measure to avoid the danger
- ▶ Further measures

Embedded warning notice

Embedded warning notices refer to a certain area within a section. They apply to smaller information units than the section-related warning notices. Embedded warning notices are structured as follows:

⚠ DANGER! Instructions for avoiding a dangerous situation.

2.4 Intended use

The product complies with laws, regulations and standards valid at the time of delivery.

The product does not pose a danger to people, property or environment if it is used for its intended purpose and the warning notices contained in this operating manual and attached to the product are observed. This applies to the entire lifetime, from the delivery, assembly and operation to the disassembly and disposal.

The following is deemed to be used for the intended purpose:

- Operate the product exclusively in accordance with this operating manual and in accordance with the specification in the order confirmation and the device pass.
- Use exclusively original ARCA spare parts for the maintenance of the product.



⚠ DANGER

Risk of death and serious injuries as well as damage to property and the environment!

Risk of death and serious injuries as well as damage to property and the environment due to hazardous operating media, high temperatures and pressures as well as moving parts.

- ▶ The following requirements and conditions must be complied with without fail.
- ▶ Observe warning notices.

Maintenance

Ensure or observe the following before performing any maintenance work:

- Depressurise the pipeline.
- Completely empty the pipeline and, in the case of hazardous operating media, thoroughly rinse it using a suitable cleaning fluid.
- Inform yourself about possible hazards that could arise due to residues of the operating medium and take suitable precautions if necessary. (Wear personal protective equipment, etc.).
- If necessary, cool the valve down or heat it up to ambient temperature.

- Disconnect the auxiliary energy supply to the actuator and drive it to its end position.
- Ensure that the system cannot be started up by third parties.
- You are expressly directed to observe the regulations for potentially explosive equipment where necessary.

2.5 Inappropriate use

Inappropriate use is use of the product other than as described in the chapter entitled [2.4] *Intended use*.

In addition, the following applies:

- Unauthorised modifications to the product can lead to injuries, damage to property and malfunctions. The user alone bears this risk. Warranty and liability claims are excluded.

2.6 Residual risks

There may still be residual risks even if the product is used for its intended purpose.

- Danger of being crushed by unsecured actuators

In case of negligent use of personal protective equipment:

- Danger due to noise resulting in hearing loss
- Thermal hazards (burning, scalding, etc.)
- Danger due to escape of the operating medium

Furthermore, there may be unapparent residual risks despite all precautions taken.

Residual risks can be minimised if the notes on safety and commissioning as well as the operating manual as a whole are observed.

2.7 Qualification of the personnel

The product is exclusively intended for use in plants and installations in which trained technical personnel carry out the necessary work. Technical personnel are persons who are entrusted with the installation, commissioning and operation of this product and who have the appropriate qualifications for their work activities, such as, for example:

- training or instruction in accordance with current technical safety standards in the maintenance and usage of appropriate safety equipment.
- Training in First Aid.
- In the case of systems with explosion protection: training or instruction and authorisation to carry out work on potentially explosive systems.

Repair work may be carried out only by trained and qualified technical personnel.

Work on electrical equipment may be carried out only by trained electricians or persons who have received electrotechnical instruction.

Persons	Instructed persons	Persons with a recognised technical education	Persons with a recognised electrotechnical education	Superiors with relevant skills	ARCA service personnel
Transport	X	X	X	X	X
Installation	X	X	X	X	X
Commissioning		X	X	X	X
Maintenance	X	X	X	X	X
Fault finding		X	X		X
Mechanical troubleshooting		X			X
Electrical troubleshooting			X		X
Repairs		X	X	X	X
Disposal	X	X	X	X	X

2.8 Operator's duty of care

To avoid accidents, malfunctions and environmental impacts, the respective person responsible for the transport, commissioning, operation, maintenance and disposal of the product must ensure the following:

- Observation of all warning and danger notices.
- Regular instruction of personnel on all applicable questions of work safety, the operating manual and in particular the safety instructions that it contains.
- Regulations and work instructions for safe working as well as the corresponding instructions for the conduct of the personnel in case of accidents and fire are to be kept at the ready at all times and hung up in the plant if necessary.
- Operate the product only if it is in perfect working order.
- Use only spare parts, lubricants and operating resources approved by the manufacturer.
- Observe the specified operating conditions and requirements at the place of installation.
- Provide all necessary devices and the personal protective equipment required for the respective task.
- Refer to the chapter entitled Maintenance for the prescribed maintenance intervals and comply with the corresponding regulations.
- Allow installation, commissioning and maintenance of the product to be carried out only by qualified and trained personnel in accordance with this operating manual.
- The operator must ensure that the product is used for its intended purpose.
- Before commissioning the product the operator must carry out a risk assessment and define appropriate inspection and maintenance intervals according to the operating conditions.

2.9 Personal protective equipment

Personal protective equipment must be worn during work in order to minimise health risks.

- During work, always wear the protective equipment necessary for the respective work
- Follow the notices about personal protective equipment displayed in the working area.

Always wear	
	<p>Protective clothing</p> <p>Tight-fitting work clothes with a low tear resistance, with narrow sleeves and without protruding parts. They primarily serve to protect against being caught up by moving machine parts.</p> <p>Do not wear rings, chains or other jewellery.</p>
	<p>Safety shoes</p> <p>To protect against heavy falling parts and slipping on smooth floors.</p>
Wear in case of particular environmental conditions	
	<p>Special protective equipment is necessary in particular environmental conditions.</p> <p>It is to be selected according to the environment.</p> <p>Safety glasses</p> <p>To protect the eyes against flying parts and splashes of liquids.</p>
	<p>Helmet</p> <p>To protect against falling and flying parts and materials.</p>
	<p>Hearing protection</p> <p>To protect against hearing damage.</p>

3 Transport, storage and packaging

3.1 Transport



WARNING

Tipping or falling load!

Danger of death and danger of damage to property due to load tipping over or falling!

- ▶ Only suitable and approved means of transport and lifting equipment may be used for transporting the product.
- ▶ Lifting equipment must generally be attached to the housing of the product, not to attachments.
- ▶ Allow only instructed persons to select and attach the lifting equipment.
- ▶ Do not stand under suspended loads.

Transport at a temperature lower than -40 °C or higher than $+80\text{ °C}$ is not permissible.

The valve may only be transported in a pressureless and rinsed-out condition.

Particular attention is to be paid to dead spaces (pressure compensation, bellows, etc.) when rinsing the valve.

3.2 Storage



NOTICE

Improper storage!

There is a danger of the product and in particular the attached electronic accessories no longer functioning if stored improperly.

- ▶ Storage at a temperature lower than -40 °C or higher than $+80\text{ °C}$ is not permissible.
- ▶ It must be stored in roofed-over storage places and that are weather-proof.

To protect against contamination and to protect the sealing surfaces, openings such as nozzles, flanges, etc. must be sealed using suitable means. These should be removed by technical personnel at the place of installation.

3.3 Packaging

The product is packed in a PE film inside the outer packaging (cardboard box, wooden crate, pallet, lattice box).

If the packaging, in particular the PE film, has been opened, the product must be stored immediately in a heated room.

The product must be packed in weatherproof or seaworthy packaging for transport by ship, airplane, rail or truck.

4 Nameplate

CONTROL-VALVE	App.-No.	1	Series	2				
	Body-Type	3	DN	4		mm PN	5	
	Kv	6	Seat- ϕ	7		mm Stroke	8	mm
	Material	9				Function	10	
	Servo-Motor	11	Air-Supply	12		Signal-Range	13	
	14							

Illustration 2: Nameplate

1	App. no. / Serial no.
2	Type designation / Year of manufacture
3	Valve design
4	Nominal size
5	Nominal pressure
6	Flow coefficient, characteristic curve
7	Seat diameter
8	Valve stroke
9	Material of housing / trim
10	Actuator function
11	Actuator type
12	Max. actuation pressure
13	Actuation pressure range
14	Actuator type key

Place of installation

The nameplate is attached to the actuator yoke or the actuator head.

Serial no.

The serial no. of the valve is stamped on the neck flange of the housing. If it differs from the type plate, the serial no. on the housing is binding.

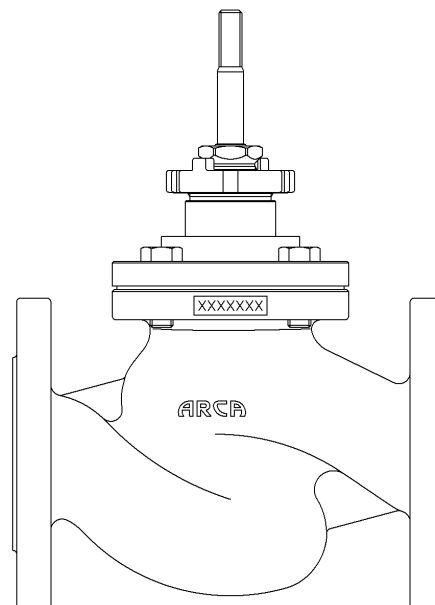

Illustration 3: Serial no.

5 Type key

Series	
8C-	
Bonnet (..X)	
--1	Standard
--2	Double stuffing box
--3	Cooling fins
--4	Bellows
--5	Extension (insulating column)
--7	Standard balanced
--8	Cooling fins balanced
--9	Special design in acc. with order
Trim (...-XX)	
P1 – P5	Parabolic plug (1 - 5 step)
L1 – L4	Perforated plug (1 - 4 step)
S	On/off plug
LN	Retainer (low-noise, single, double)
LK1 – LK4	Low noise cage (single to quadruple)
SLK1 – SLK3	Seat low noise cage (single to triple)
LS1 – LS4	Perforated disc, welded in (single to quadruple)
SS	Dirt strainer
BG	Additional lower stem guide in the seat

Example of type designation

8C3-P1-LN

Control valve ECOTROL 8C – cooling fins – bonnet – 1 step parabolic plug – low-noise retainer

6 Sectional drawings

Some versions of the valve are illustrated below. Further versions are possible by combining the different components.

Drawing details

X see [10.3] *Stem sealing*

Y see [11.11] *Retainer & seat*

Z see [11.10] *Balancing sealing*

6.1 Parts list

Item	Name
1	Housing
2	Bonnet
6	Intermediate flange
20	* Seat
26	* Plug (compl.)
50	* Stem
51	* Clamping sleeve
56	* Shaft
57	* Hex nut
59	* Lock washer
60	Cylinder tube
65	Guide bush
80	* Screw(bolt)
81	* Nut
90	* Screw(bolt)
110	Low noise cage
117	* Wiper ring
140	* Gasket
142	* Bellows unit
143	* Gasket
144	* Gasket
150	Slotted nut
152	Stuffing box screw
154	* Base ring
156	* Seal set
164	* Plain bearing
166	* O-ring
168	* Gasket
169	Sleeve
170	Stuffing box gland
172	* Screw
173	* Spring lock washer
177	* Piston ring
180	* Sealing element

Item	Name
181	Clamping ring
182	Retainer
183	* O-ring
184	* Sealing element
185	Lower guide
186	* Plain bearing
198	* Sealing element
199	* Support ring
356	* Sealing element
523	Disc
	* recommended spare part / wearing part

6.2 8C1-P1

Standard bonnet DEK1 with parabolic plug P1.

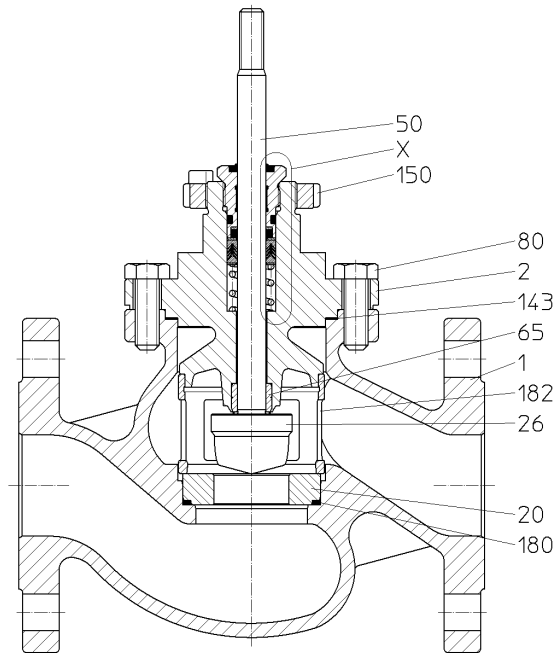

1	Housing
2	Bonnet
20 *	Seat
26 *	Plug (compl.)
50 *	Stem
65	Guide bush
80 *	Screw(bolt)
143 *	Gasket
150	Slotted nut
180 *	Sealing element
182	Retainer
* recommended spare part / wearing part	

Illustration 4: 8C1-P1

6.3 8C1-P1

Standard bonnet DEK1 with parabolic plug P1 and soft seal. See also [11.11] Version with soft seal – Detail Y

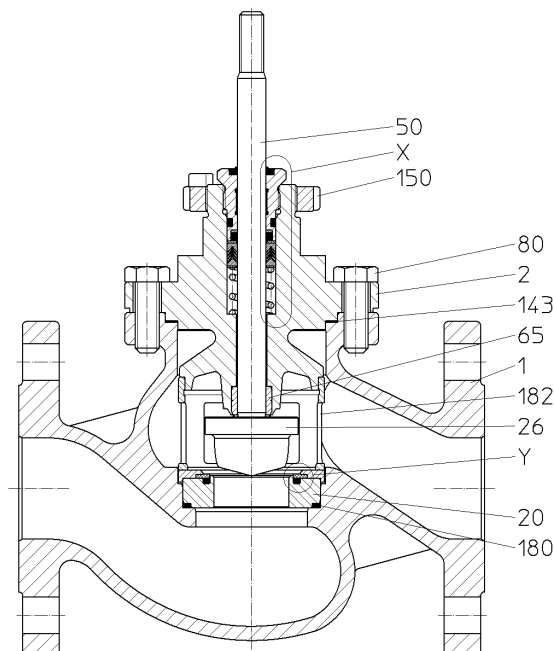

1	Housing
2	Bonnet
20 *	Seat
26 *	Plug (compl.)
50 *	Stem
65	Guide bush
80 *	Screw(bolt)
143 *	Gasket
150	Slotted nut
180 *	Sealing element
182	Retainer
* recommended spare part / wearing part	

Illustration 5: 8C1-P1

6.4 8C1-L1-LK1

Standard bonnet DEK1 with perforated plug L1 and low noise cage LK1.

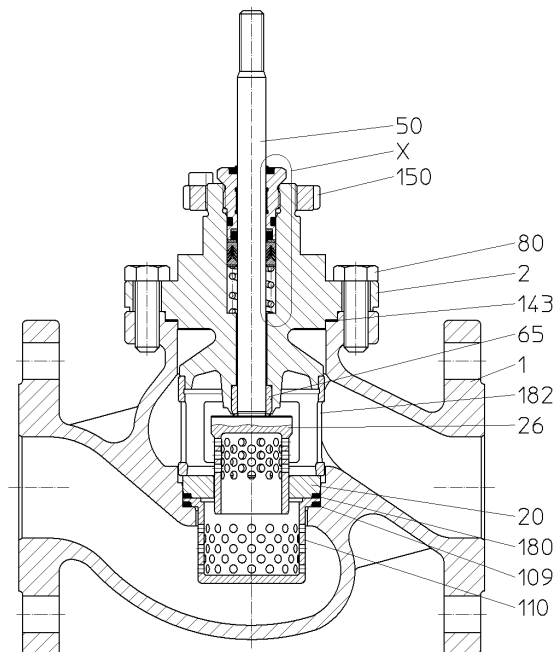

1	Housing
2	Bonnet
20 *	Seat
26 *	Plug (compl.)
50 *	Stem
65	Guide bush
1	
182	
26	
109 *	Gasket
110	Low noise cage
143 *	Gasket
150	Slotted nut
180 *	Sealing element
182	Retainer
* recommended spare part / wearing part	

Illustration 6: 8C1-L1-LK1

6.5 8C1-P1-BG

Standard bonnet DEK1 with parabolic plug P1 and lower guide BG.

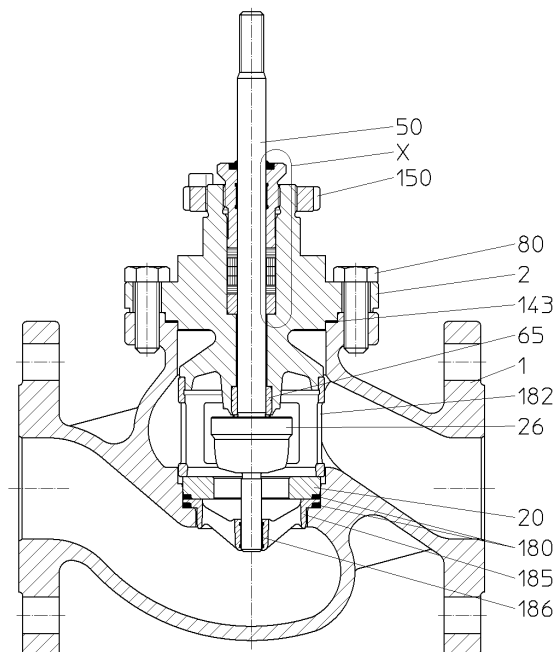

1	Housing
2	Bonnet
20 *	Seat
26 *	Plug (compl.)
50 *	Stem
65	Guide bush
1	
182	
26	
143 *	Gasket
150	Slotted nut
180 *	Sealing element
182	Retainer
20	
180	
185	Lower guide
186 *	Plain bearing
* recommended spare part / wearing part	

Illustration 7: 8C1-P1-BG

6.6 8C3-L1

Bonnet with cooling fins DEK3 and perforated plug L1.

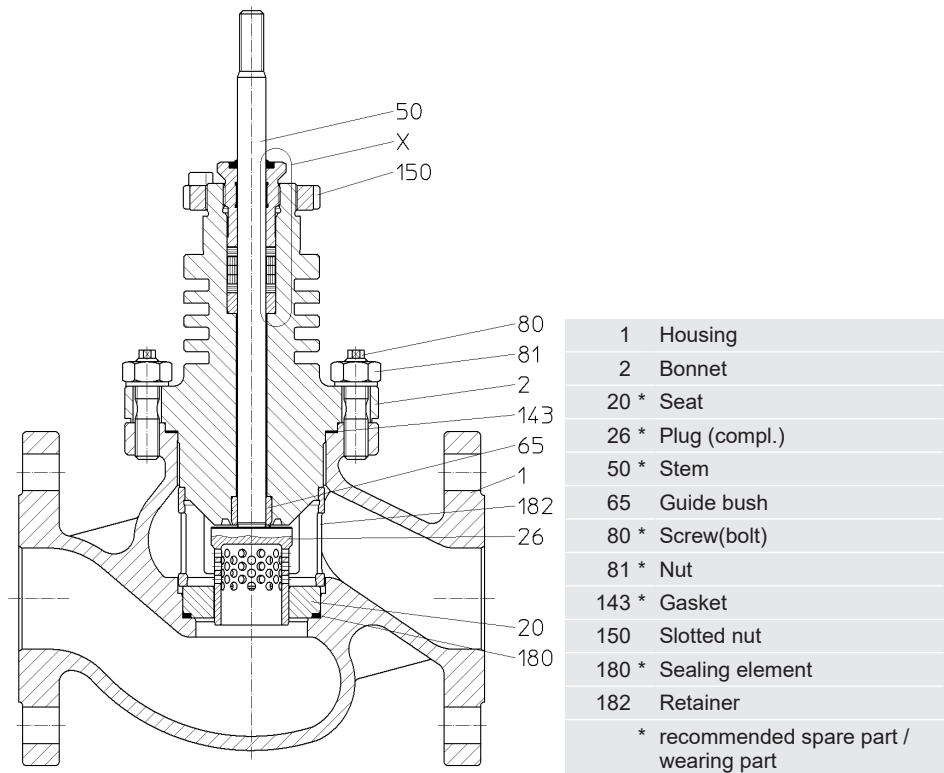
*Illustration 8: 8C3-L1*

6.7 8C4-P1

Bonnet with bellows DEK4 and parabolic plug P1.

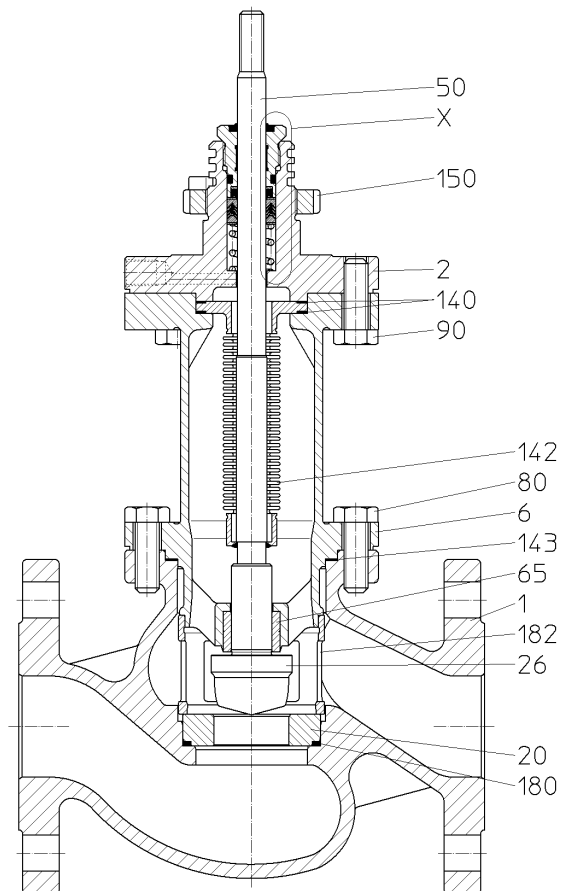

1	Housing
2	Bonnet
6	Intermediate flange
20 *	Seat
26 *	Plug (compl.)
50 *	Stem
65	Guide bush
80 *	Screw(bolt)
90 *	Screw(bolt)
140 *	Gasket
142 *	Bellows unit
143 *	Gasket
150	Slotted nut
180 *	Sealing element
182	Retainer
* recommended spare part / wearing part	

Illustration 9: 8C4-P1

6.8 8C5-P1 to -50 °C

Bonnet with insulating column DEK5 and parabolic plug P1.

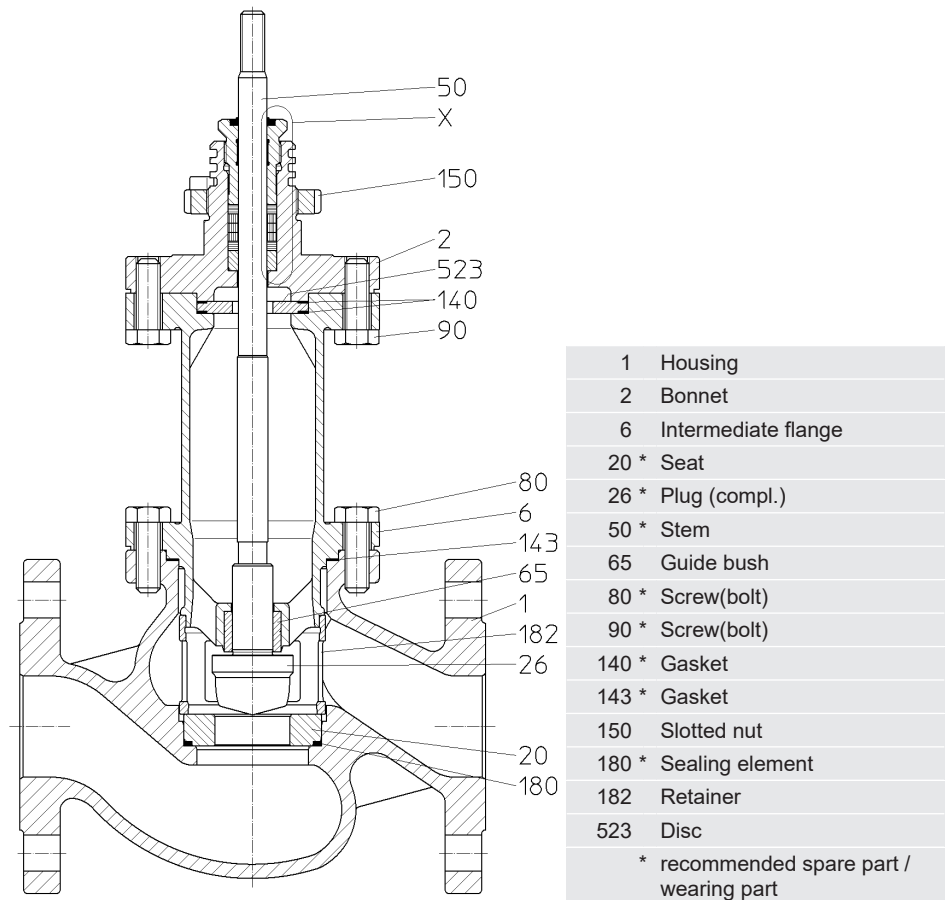
*Illustration 10: 8C5-P1*

6.9 8C7-P1

Bonnet with balancing system DEK7 and parabolic plug P1. See also [11.10] *Balancing seal – Detail Z*

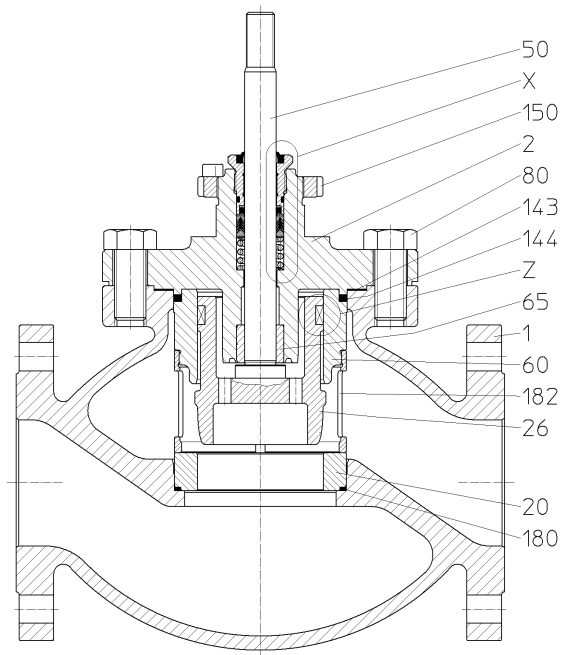

1	Housing
2	Bonnet
20 *	Seat
26 *	Plug (compl.)
50 *	Stem
60	Cylinder tube
65	Guide bush
80 *	Bolt / threaded bolt
143 *	Gasket
144 *	Gasket
150	Slotted nut
180 *	Sealing element
182	Retainer
	* recommended spare part / wearing part

Illustration 11: 8C7-P1

7 Functional description

Valves from this series are usually used as actuators within the meaning of DIN IEC 60050-351.

The valve serves to reduce the pressure and quantity of a flow of medium through the plug.

The flow of medium through the seat (20) is regulated by the position of the plug (26). The plug (26) is adjusted with the aid of an attached actuator, which acts on the Stem (50) connected to the plug (26).

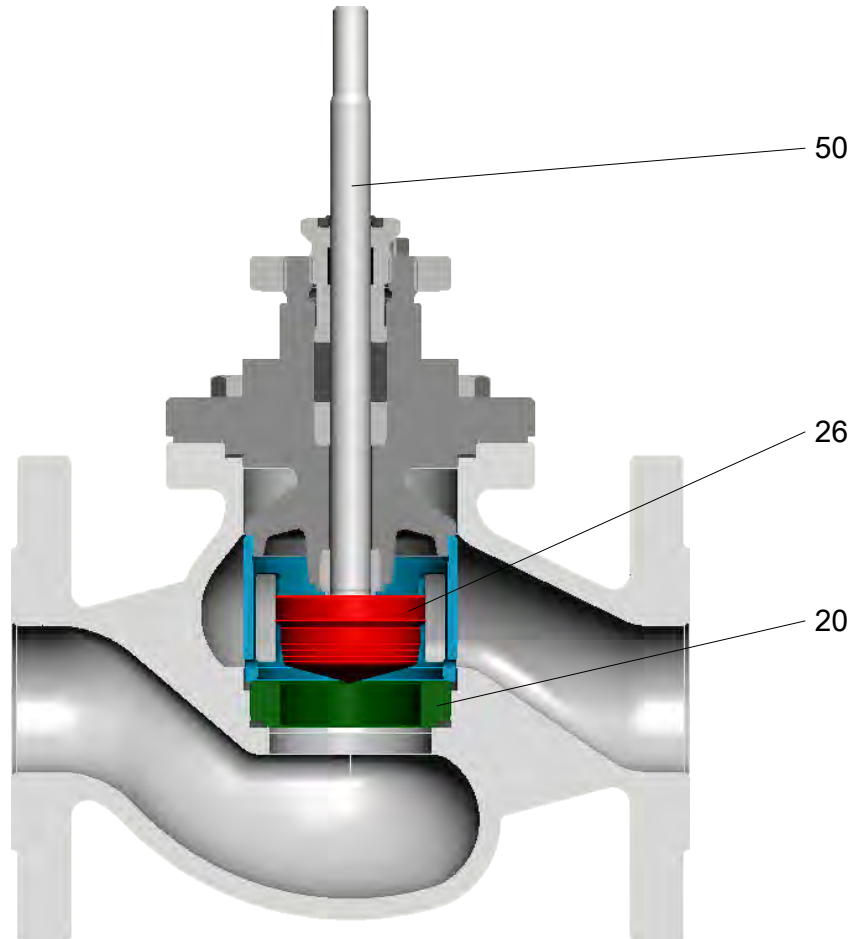

Illustration 12: Sectional drawing

8 Fitting

Place of installation

The valve should be easily accessible from at least one side.
 Include a catwalk or similar in the planning in case of greater heights.
 An electric crane or block and tackle should be provided, depending on the weight.

Valve with flanges

After removal of the protective caps from the inlet and outlet sealing surfaces, valves with flanges are installed in the pipeline using gaskets and bolts provided by the customer. Following the installation, check the flange connection and the surface coating, in particular the area around the contact surfaces of the flange joints. Damage to the coating caused by transport or installation in the pipeline is to be treated with a suitable coating system in order to restore the factory corrosion protection.

Valve with welded ends

Valves with welded ends are welded into the pipeline. Following the installation, check the welded connection and the surface coating. Damage to the coating caused by transport or installation in the pipeline is to be treated with a suitable coating system in order to restore the factory corrosion protection.

Please note:



⚠ CAUTION

Mounting position

- ▶ Pipeline horizontal
- ▶ Actuator above the valve
- ▶ Pay attention to the flow direction arrow on the housing flange

In case of a different mounting position, special measures need to be taken to support the weight of the actuator!

Forces from the pipeline must not be transmitted to the valve.
 A straight section of pipeline with a length of at least 10x the nominal size of the pipeline must be provided for in front of and behind the valve.
 Built-in parts and branches are not permitted.
 A bypass line is recommended with shut-off valves before and after the valve.

It recommended to install a dirt trap / filter before the valve.

NOTICE! Following the installation of the valve, check that the installation conditions mentioned have been met.

Attachment of an actuator

The valve enables the attachment of different actuators. Various mounting kits and couplings are available for this.
 The actuator must be mounted according to the actuator manufacturer's operating manual. The maximum permissible actuating forces must be observed.

DN	Stem thread	Max. actuating force [kN]
15 - 65 → 1/2" - 2 1/2"	M12	16
80 - 100 → 3" - 4"	M18x1.5	41

**⚠ CAUTION**

The following must additionally be observed when constructing an electric or hydraulic actuator:

- ▶ Switch-off in the closing direction via torque switch
- ▶ Switch-off in the opening direction via displacement switch

9 Commissioning / Decommissioning

Before the initial commissioning	<p>In order to avoid damage to the trim due to possible existing contamination in the piping network, the piping network must be cleaned by rinsing and if necessary pickling.</p> <p>The following procedures are recommended:</p>
Rinsing with rinsing set	<p>A rinsing set and rinsing flange(s) is mounted in place of the trim.</p> <ul style="list-style-type: none"> ▪ Completely dismantle the valve so that only the housing remains in the pipeline ▪ Mount the rinsing set in place of the seat (to be ordered separately) ▪ Mount the rinsing flange(s) (to be ordered separately) ▪ Rinse and if necessary pickle ▪ Dismount the rinsing set and the rinsing flange(s) ▪ Clean the valve and replace the seal(s) ▪ Mount the trim and completely reassemble the valve
Rinsing with spacer	<p>A spacer is installed in the pipeline in place of the valve</p> <ul style="list-style-type: none"> ▪ Remove the valve from the pipeline (flange-mounted valves only) ▪ Install the spacer in the pipeline ▪ Rinse and if necessary pickle ▪ Remove the spacer from the pipeline again ▪ Replace the seals ▪ Install the valve in the pipeline again
Commissioning	<ul style="list-style-type: none"> ▪ Pay attention to the chapter entitled [2] <i>Safety</i> ▪ Avoid thermal shocks <ul style="list-style-type: none"> – Bring the valve slowly up to operating temperature At a temperature difference of 300 K or more, the speed of temperature change must be restricted to max. 2 K/min. ▪ Check the flange connections for leaks <ul style="list-style-type: none"> – Tighten the bolted connections diagonally. Refer to the chapter entitled [12] <i>Torque tables</i> for the tightening torques ▪ Check the stem sealing for leaks <ul style="list-style-type: none"> – See the chapter entitled [10.3] <i>Stem seal – Detail X</i> for this
Decommissioning	<p>We recommend the following procedure for taking the valve out of service:</p>
The valve remains installed	<p>In case of lengthy standstills, the valve and the pipeline must be emptied and rinsed, depending on the operating medium.</p>
The valve is removed	<ul style="list-style-type: none"> ▪ Pay attention to the chapter entitled [2] <i>Safety</i> ▪ Remove the valve from the pipeline ▪ Treat the interior of the housing with a suitable preservative and seal the openings with suitable caps

- To protect against corrosion, treat all unpainted parts and surfaces made of materials that are not rustproof with a suitable preservative

Recommissioning

NOTICE! All seals must be replaced if the valve has been out of service for more than one year.

- Mount the valve in accordance with the chapter entitled [8] *Fitting*
- Carry out the work according to the chapter entitled [10.1] *Care*
- Commission the valve according to the chapter entitled [9] *Commissioning*

10 Maintenance

10.1 Care

- Clean the stem (50) if necessary
 - Clean the stem (50) of adhering dirt using a soft cloth

NOTICE! Never use sandpaper, since this will damage the surface of the stem and reduce the lifetime of the stem sealing.

10.2 Maintenance

The valve is for the most part maintenance-free.

Nevertheless, the flange connections and the stuffing box seal must be checked regularly for leaks. If necessary the work is to be carried out in accordance with the chapter entitled [9] *Commissioning*. Depending on the operating conditions of the valve, the operator is responsible for defining appropriate checking and maintenance intervals.

10.3 Stem seal – Detail X



NOTICE

In general we wish to point out that all types of stuffing box seals are subject to wear due to the respective operating conditions and must be inspected and if necessary replaced at regular intervals.

Stuffing box seal with V-collar

The stuffing box seal with V-collar is not adjustable. In case of leaks the entire seal set must be exchanged.

Stuffing box seal with packing rings

The stuffing box seal with packing rings is adjustable. The stuffing box screw (152) can be tightened if the stuffing box seal should leak.

The stuffing box screw should only be tightened to the extent that the force of the actuator still allows jerk-free movement of the stem (50).

If the stuffing box screw (152) is tightened too much and the stem (50) jams or jerks, the stuffing box screw (152) must be loosened again until jerk-free operation is possible. Nevertheless, the sealing integrity must still be guaranteed.

Packing rings can be added if no further tightening of the stuffing box screw (152) is possible. See section entitled **Addition of packing rings**.

Stuffing box seal with shaped ring

The stuffing box seal with shaped ring is not adjustable. In case of leaks the entire seal set must be exchanged.

Addition of packing rings

Split packing rings can be temporarily added.

However, an exchange of the complete stuffing box seal should take place as soon as possible.

- Pay attention to the chapter entitled [2] *Safety*
- **!WARNING!** Drive the actuator to the upper end position and secure it
- Unscrew and remove the stuffing box screw (152)

- Carry out the work according to the chapter entitled [10.1] *Care*
- Insert a split packing ring
- Fit the stuffing box screw (152)
- Commission the valve according to the chapter entitled [9] *Commissioning*

Stuffing box chamber sleeve

In order to prevent corrosion of the stuffing box chamber, a sleeve (169) made of stainless steel is inserted in the case of bonnets made of materials that are not rustproof.

10.3.1 V-collars

V-collars

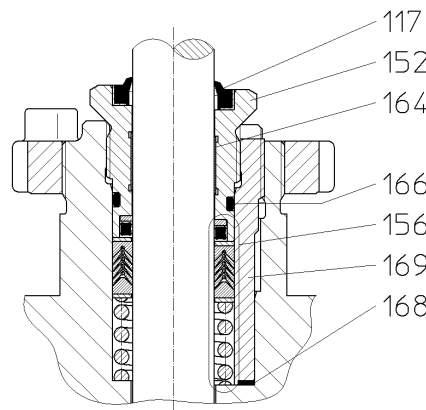

117 *	Wiper ring
152	Stuffing box screw
156 *	Seal set
164 *	Plain bearing
166 *	O-ring
168 *	Gasket
169	Sleeve
* recommended spare part / wearing part	

Illustration 13: V-collars

V-collars vacuum operation

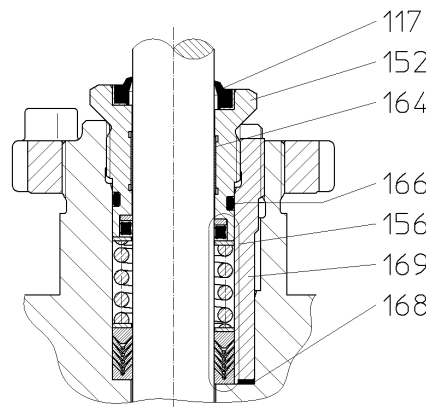

117 *	Wiper ring
152	Stuffing box screw
156 *	Seal set
164 *	Plain bearing
166 *	O-ring
168 *	Gasket
169	Sleeve
* recommended spare part / wearing part	

Illustration 14: V-collars vacuum operation

10.3.2 Packing rings

Packing rings

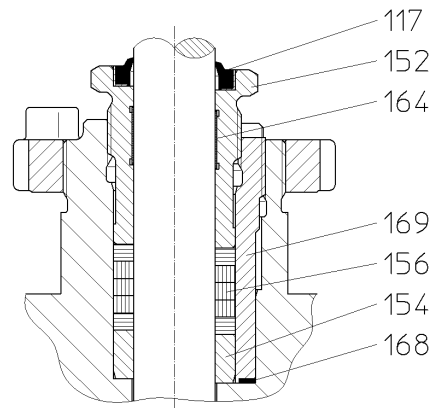

117 *	Wiper ring
152	Stuffing box screw
154 *	Base ring
156 *	Seal set
164 *	Plain bearing
168 *	Gasket
169	Sleeve
* recommended spare part / wearing part	

Illustration 15: Packing rings

10.3.3 Shaped ring

Double quad ring

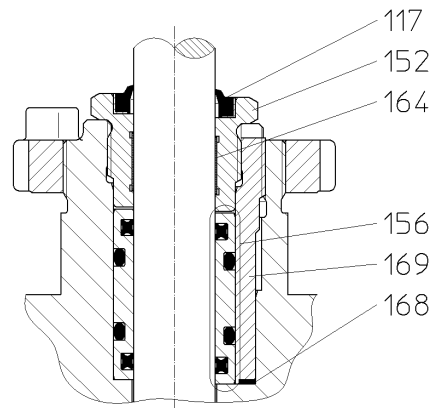

117 *	Wiper ring
152	Stuffing box screw
156 *	Seal set
164 *	Plain bearing
168 *	Gasket
169	Sleeve
* recommended spare part / wearing part	

Illustration 16: Double quad ring

Variseal ring

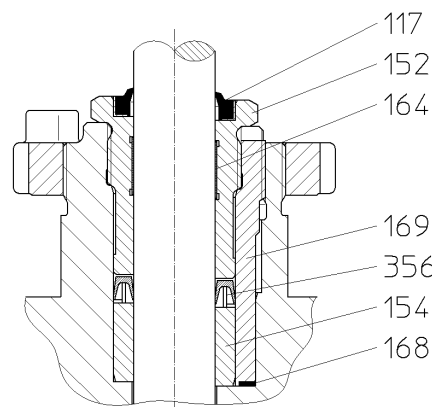

117 *	Wiper ring
152	Stuffing box screw
154 *	Base ring
164 *	Plain bearing
168 *	Gasket
169	Sleeve
356 *	Sealing element
* recommended spare part / wearing part	

Illustration 17: Variseal ring

11 Disassembly / assembly of the valve



⚠ WARNING

Disregarding the safety instructions

Risk of injury!

- ▶ Observe the notes in the chapter entitled [2] *Safety*

11.1 Procedure

- Disassembly of the valve.
 - Dismounted parts are to be secured carefully against falling down (risk of injury or damage).
- Clean all components.
- Assembly in the reverse order using the new components.
 - Seals and packings are generally to be replaced.
 - Insert any existing dynamically loaded O-rings and shaped rings using a suitable lubricant, provided that the process conditions allow.
 - Refer to the chapter entitled [12] *Torque tables* for the tightening torques of bolted connections.
 - Following assembly, the plug must be moved to the upper and lower end positions by hand or using auxiliary energy. The plug may neither jerk nor scrape when doing this.
 - If necessary the bonnet connections must be loosened, the components re-aligned to one another and the connections tightened again.
 - Then commission the valve according to the chapter entitled [9] *Commissioning*.

11.2 Actuator

- **⚠ WARNING!** Drive the actuator to the central stroke position and secure it.
- Decouple and remove the actuator.
 - Follow the actuator manufacturer's mounting instructions!

11.3 Bonnet

Standard/cooling fins/
insulating column versions
down to -196 °C

- Unscrew the stuffing box screw (152)
 - Refer also to the chapter entitled [10.3] *Stem sealing – Detail X* for this
- Release the bolted connection between the housing (1) and the bonnet (2)
- Lift off the bonnet (2)
 - **⚠ CAUTION!** The plug (26) may be lifted off with the bonnet (2)
 - Pull the plug (26) out of the bonnet (2)
 - Do not bend the stem (50)

Bellows/insulating column versions down to -50 °C

- Unscrew the stuffing box screw (152)
 - Refer also to the chapter entitled [10.3] *Stem sealing – Detail X* for this
- Release the bolted connection between the bonnet (2) and the intermediate flange (6)
- Lift off the bonnet (2)
 - ⚠ **CAUTION!** Do not bend the stem (50)!

11.4 Stem sealing**V-collars**

- Remove the seal set (156) consisting of V-collar, support disc and spring
 - Refer also to the chapter entitled [10.3] *Stem sealing – Detail X* for this

Packing rings

- Remove the sealing set (156) and the base ring (154)
 - Refer also to the chapter entitled [10.3] *Stem sealing – Detail X* for this

Double quad ring

- Seal set (156)
 - Refer also to the chapter entitled [10.3] *Stem sealing – Detail X* for this

Variseal ring

- Remove the sealing element (356) and the base ring (154)
 - Refer also to the chapter entitled [10.3] *Stem sealing – Detail X* for this

11.5 Plain bearing

- Remove the plain bearing (164) from the stuffing box screw (152)
 - ⚠ **NOTICE!** Observe the following when mounting the plain bearing (164):
 - Coated side towards the stem (50)
 - Fabric side towards the stuffing box screw (152)

11.6 Intermediate flange (version with bellows)

- Release the bolted connection between the housing (1) and the intermediate flange (6)
- Lift off the intermediate flange (6) with bellows (142) and plug (26)
 - ⚠ **NOTICE!** For version with balancing system, also lift cylinder tube (60)
 - ⚠ **CAUTION!** Observe the following during the lifting:
 - Do not bend or damage the stem (50)!
 - The lifting device must be fastened to the stem thread to prevent overstretching the bellows (142)!

11.7 Cylinder tube (version with balancing system)

Standard

- Pull out the cylinder tube (60)
 - Depending on the size and version, use a mounting thread and if necessary lifting equipment

Version with bellows

The cylinder tube (60) can be taken off only after disassembly of the plug (26). Refer to the chapter entitled Plug → version with bellows for this.

11.8 Plug

Depending on the version the plug (26) has already been dismantled.

Standard

- Pull the plug (26) with the stem (50) out of the housing (1)

Version with bellows

The plug can be exchanged only in connection with **new** bellows (142). However, the bellows (142) can be exchanged without a new plug (26). Refer also to the chapter entitled [11.9] Stem → version with bellows for this.

11.9 Stem

Standard

The stem (50) can only be exchanged complete with the plug (26).

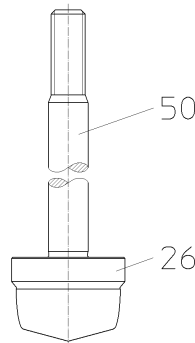

26 * Plug (compl.)

50 * Stem

* recommended spare part / wearing part

Illustration 18: Plug/stem fastening – standard

Example illustration with parabolic plug

Version with bellows

The stem can only be exchanged complete with bellows unit (142).

- Remove the clamping sleeve (51)
 - To do this, compress the bellows unit (142) with the help of the stem (50)
- Unscrew the plug (26)
 - ⚠ **CAUTION!** The bellows unit (142) must not be subjected to twisting forces!
- Replace the seal (140)
- Insert the new stem (50) with bellows (142) into the intermediate flange (6), screw on the plug (26) and drill

- Drive in the clamping sleeve (51)

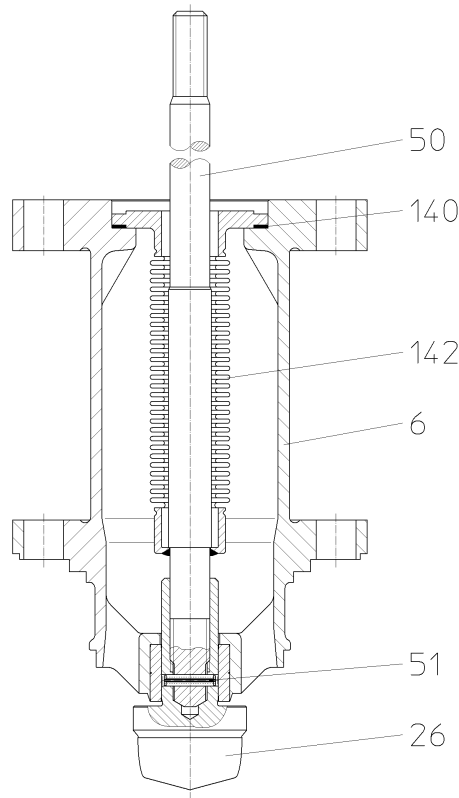

6	Intermediate flange
26 *	Plug (compl.)
50 *	Stem
51 *	Clamping sleeve
140 *	Gasket
142 *	Bellows unit
* recommended spare part / wearing part	

Illustration 19: Plug/stem fastening - bellows
 Example illustration with parabolic plug

Version with insulating column The stem (50) can be exchanged.

- Remove the clamping sleeve (51)
- Unscrew and remove the stem (50) and exchange it
- Screw the new stem (50) to the plug (26) and drill
- Drive in the clamping sleeve (51)

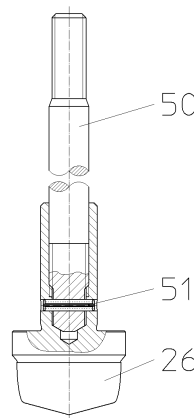

26 *	Plug (compl.)
50 *	Stem
51 *	Clamping sleeve
* recommended spare part / wearing part	

Illustration 20: Plug/stem fastening – insulating column
 Example illustration with parabolic plug

Version with balancing system The stem (50) can be exchanged.

- Unscrew and remove the hex nut (57) and replace it

- Take off and replace lock washer (59)
- Pull the stem (50) out of the plug (26)

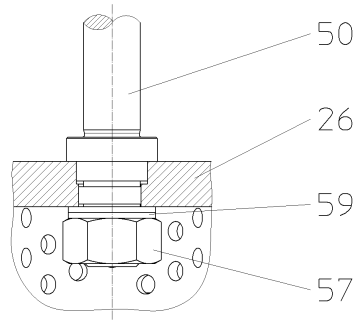

26 * Plug (compl.)
50 * Stem
57 * Hex nut
59 * Lock washer
* recommended spare part / wearing part

Illustration 21: Plug/stem fastening – balancing system

Example illustration with perforated plug

11.10 Balancing seal - Detail Z (version with balancing system)

Quad ring

- Exchange the sealing element (198) and support rings (199)

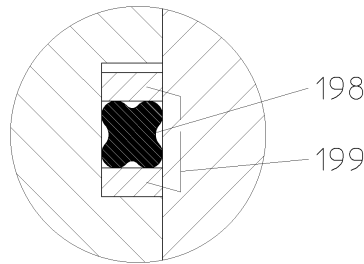

198 * Sealing element
199 * Support ring
* recommended spare part / wearing part

Illustration 22: Balancing seal quad ring – Detail Z

Piston rings

- Dismount the piston rings (177) using a piston ring expander

NOTICE! During assembly, the piston rings must be positioned in accordance with the embossed marking "TOP" in relation to the respective flow direction (FTO / FTC). The piston ring joints must be arranged with an offset of 180 degrees to one another.

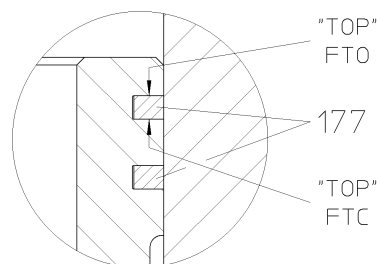

177 * Piston ring
* recommended spare part / wearing part

Illustration 23: Balancing seal piston rings – Detail Z

Variseal ring

- Replace sealing element (198)
 - Observe the flow direction (FTO / FTC)

NOTICE! Warm up the sealing element in a water bath before assembly. The expanded sealing element must be calibrated after assembly. The cylinder tube (60) can be used as a calibration sleeve for this purpose.

FTO

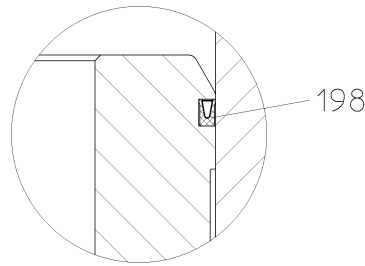

198 * Sealing element
* recommended spare part / wearing part

Illustration 24: Balancing seal Variseal ring FTO – Detail Z

FTC

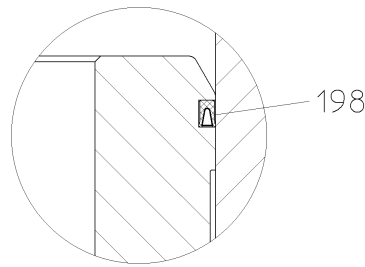

198 * Sealing element
* recommended spare part / wearing part

Illustration 25: Balancing seal Variseal ring FTC – Detail Z

11.11 Retainer & seat

Standard

- Take the retainer (182) and seat (20) out of the housing (1)
- Exchange sealing element (180)

Version with soft seal – Detail Y

Flat gasket & O-ring

- Take the retainer (182), clamping ring (181) and complete seat (20, 183, 184) out of the housing (1)
- Replace the sealing element (184) and O-ring (183)
- Exchange sealing element (180)

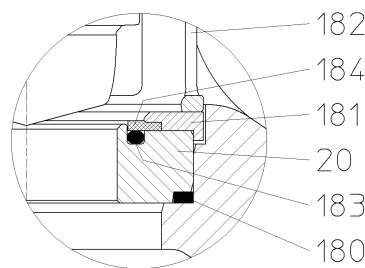

20 * Seat
180 * Sealing element
181 Clamping ring
182 Retainer
183 * O-ring
184 * Sealing element
* recommended spare part / wearing part

Illustration 26: Soft seal, flat gasket & O-ring – Detail Y

Example illustration with parabolic plug

Trapezoidal ring

- Take the retainer (182), clamping ring (181) and complete seat (20, 184) out of the housing (1)
- Exchange sealing element (184)

- Exchange sealing element (180)

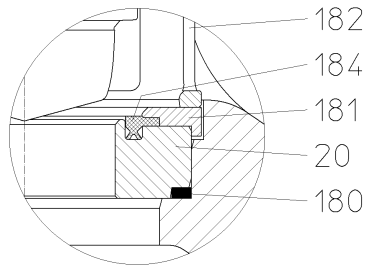

20 *	Seat
180 *	Sealing element
181	Clamping ring
182	Retainer
184 *	Sealing element
*	recommended spare part / wearing part

Illustration 27: Soft seal, trapezoidal ring – Detail Y

Example illustration with parabolic plug

12 Torque tables - bolted connections

12.1 Screws according to DIN EN ISO 4017/4014, DIN 939

Thread	Torque [Nm/lbf ft]
	A2-70
M8	13/10
M10	30/22
M12	50/37
M16	120/90
M20	230/170
M24	390/290
M27	580/430

12.2 Screws according to DIN 2510

Thread	Torque [Nm/lbf ft]				
	A2-70	1.7709	1.7218	1.4923	1.4913
M10 *	19/14	23/17	19/14	25/18	32/24
M12	35/26	40/30	35/26	45/33	60/44
M14	50/37	65/48	50/37	70/52	90/66
M16	90/66	110/80	85/63	120/90	150/110
M20	170/125	200/150	160/120	220/160	280/210
M24	280/210	350/260	280/210	380/280	470/350
M27	410/300	500/370	400/300	550/410	690/510
M30	580/430	710/520	570/420	780/580	970/720
M33	770/570	950/700	760/560	1000/740	1300/960
M36	990/730	1200/885	960/710	1300/960	1600/1180

* Works standard

12.3 Screws according to ASME B16.5

Thread	Torque [Nm/lbf ft]		
	A193B7	A193B8	A193B7M
½"-UNC	100/75	50/35	75/55
⅝"-UNC	185/135	90/66	140/100
¾"-UNC	325/240	155/110	250/180
⅞"-UNC	520/380	250/180	400/300
1"-UNC	780/580	370/270	600/440
1⅛"-UNC	1100/800	520/380	840/620
1¼"-UNC	1520/1120	730/540	1160/860

12.4 Hex nut (57)

Thread	Torque [Nm/lbf ft]
	Plug material

Thread	Torque [Nm/lbf ft]	
	1.4571, 1.4301, 1.4404, 1.4306	All other plug materials
M20x1.5	300/220	350/260
M24x1.5	500/370	600/440
M36x3	1500/1110	2000/1480
M48x2	3600/2660	4000/2950

13 Fault removal



⚠ WARNING

Improper troubleshooting work on the valve

Risk of injury!

- ▶ For all troubleshooting work on the valve, observe the corresponding notes in this operating manual or in the operating manuals for the additionally installed components.

Please contact the manufacturer if problems occur that are not described in this table.

Fault	Possible causes	Action
No flow	Valve closed	Open the valve by means of the actuator
	Flange covers (transport protection) have not been removed	Remove flange covers
Inadequate flow	Valve not opened sufficiently	Open the valve by means of the actuator
	Blockage in the piping system	Check the pipeline
	Incorrect valve or incorrect Kvs value selected	Use valve with correct Kvs value
Stem moves jerkily	Stuffing box screw overtightened (in case of valves with adjustable stem sealing)	Slacken off the stuffing box screw a little Sealing integrity must be maintained
Stem or plug doesn't move	Stuffing box screw overtightened (in case of valves with adjustable stem sealing)	Slacken off the stuffing box screw a little Sealing integrity must be maintained
	Seat and plug very dirty	Clean seat and plug
	Due to contamination in the medium, the stem or plug has eaten into its guide	Replace the stem, plug and guides
Stem seal is leaking	Stuffing box seal damaged or worn	Replace sealing element
	Stuffing box pretension too low (in case of valves with adjustable stem seal)	Tighten the stuffing box screw
Leakage rate too high in the closed state	Sealing edges on the plug and/or seat damaged	Rework or replace plug and/or seat
	Dirt/foreign bodies in the valve	Clean the interior of the valve, fit a dirt trap if necessary
	Balancing seal worn in balanced valves	Replace sealing element
	Closing force of the actuator too low	Use a more powerful actuator, Check the operating data

14 Disposal and recycling



WARNING

Operating media and auxiliary materials that are hazardous to health

Danger to people and the environment!

- ▶ Wear suitable protective equipment
- ▶ If applicable, collect and dispose of rinsing medium or residual medium. Particular attention is to be paid to dead spaces (pressure compensation, bellows, etc.)
- ▶ Observe the legal regulations for the disposal of media that are hazardous to health

ARCA products are modularly constructed and can be sorted by material into the following components.

- Electronic components
- Metals
- Plastics
- Greases and oils
- Packaging material

The general rules are:

- greases and oils are usually water pollutants and must not be allowed to escape into the environment
- Dispose of dismantled materials properly or recycle the separate materials
- Observe national disposal regulations



www.arca-valve.com