

UNA 38h

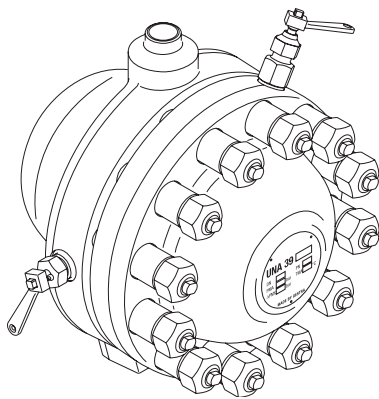

UNA 39

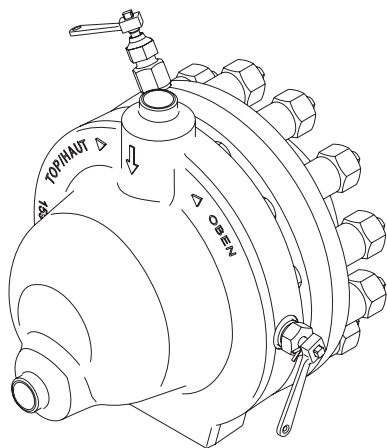

UNA 39 Rear view

Ball Float Steam Trap

UNA 38, PN 100/CL 600, DN 15-50

UNA 39, PN 160/CL 900/CL 1500, DN 15-50

Description

UNA 3.. are steam traps with ball float and needle valve for high-pressure applications. The steam traps can be used for all operating conditions, as they are unaffected by back pressure.

The steam trap UNA 3.. consists of a body with bolted cover and a control unit. Various control units are available for the steam trap.

The control unit SIMPLEX is a level-dependent float controller and especially suitable for cold condensate and superheated steam.

The control unit DUPLEX (UNA 38) is a float controller with automatic and temperature dependent deaeration facility by means of a bimetallic air vent. The control unit DUPLEX is suitable for saturated steam and superheated steam.

The control unit with orifice (O) 80 MAX (UNA 38) is designed for large flowrates and high pressures and available as SIMPLEX or DUPLEX version.

The control unit with orifice (O) 140 MAX (UNA 39) is a SIMPLEX control unit for large flowrates and high pressure.

Function

As the condensate flows into the steam trap it operates the float, which in turn opens the rolling ball valve of the control unit, and in doing so uncovers the discharge passage. The cross-sectional area of the orifice dictates the max. flowrate when the discharge passage is completely open. The max. allowable differential pressure of the control unit used depends on the cross-sectional area of the orifice and the density of the fluid to be discharged.

UNA 38 with control unit Orifice 80 MAX and UNA 39 with control unit Orifice 140 MAX:

The float controls a pilot valve as a function of the condensate level in the steam trap. If more condensate flows through the pilot valve out of the control chamber than follows through a balance opening, the pressure in the control chamber drops and the bellows of the control chamber is compressed. The main valve then opens and the condensate is discharged.

The flowing condensate moves the float ball upwards and the pilot valve closes. The vent hole ensures that the pressure between the control chamber and the interior of the steam trap is evened out such that the main valve closes.

The size of the cross-sectional area of the pilot valve and the main valve ensures only one orifice (O) is needed for the entire range of differential pressure up to 80 bar (or 140 bar).

Optional extras

Manual float-lifting lever

Hand-vent valve for version with DUPLEX control

Material for higher capacities, flanges / butt-weld ends via transition pieces: 1.7335 (UNA 38) high temperature

Flow from right to left for UNA 38
(viewed from cover end)

End connections

UNA 38

Flange EN 1092-1 B2 PN 100

Flange ASME B 16.5 CL 600 RF

Socket-weld ends to DIN EN 12760

Socket-weld ends to ASME B 16.11 CL 3000

Butt-weld ends via transition pieces EN 12627, weld joint geometry to ISO 9692-1

Code number 1.3 (30° chamfer)

Butt-weld ends via transition pieces ASME B 16.25 ASME B 36.10

UNA 39

Flange EN 1092-1 B2 PN 160

Flange ASME B 16.5 CL 900 RF

Butt-weld ends EN 12627, weld joint geometry to ISO 9692-1

Code number 1.3 (30° chamfer)

Socket-weld ends to DIN EN 12760

Socket-weld ends to ASME B 16.11 CL 6000

Design

		UNA 38 ¹⁾	UNA 39
Body connection	horizontal	●	
	vertical	●	
	angle-type		●
Orifice (O) max. differential pressure in [bar]		Orifice 50 Orifice 64 Orifice 80 Orifice 80 MAX	Orifice 80 Orifice 110 Orifice 140 Orifice 140MAX
Control unit	SIMPLEX ²⁾	●	●
	DUPLEX	●	

¹⁾ It is always possible to convert "h" to "v" design or vice versa to suit the pipework layout by repositioning the body and control unit

²⁾ incl. hand-vent valve

Materials of construction

Designation	UNA 38		UNA 39	
	EN	ASTM*	EN	ASTM*
Body	1.5415	A182-F1	1.7335	A182-F12
Flanged, socket-weld, butt-weld ends Flange / butt-weld ends via transition pieces made from	1.5415 1.7335	A182-F1 A182-F12	1.7335	A182-F12
Cover	1.7357	A217-WC6	1.7335	A182-F12
Body gasket	Graphite/CrNi	Graphite/CrNi	Graphite/CrNi	Graphite/CrNi
Stud bolts and sleeves	1.7709		1.7709	
Hexagon nuts	1.7709		1.7709	
Internals	Stainless steel	Stainless Steel	Stainless steel	Stainless Steel

* ASTM nearest equivalent grade is stated for guidance only. Physical and chemical properties comply with EN grade.

Pressure and temperature ratings

UNA 38						
End connection	Flange PN 100, socket-weld , butt-weld					
Pressure ¹⁾ p [barg]	100	85.7	69	35.2	28	22.3
Temperature ¹⁾ T [°C]	-10 / 20	300	450	510	520	530
Max. allowable differential pressure ΔPMX [psi]	50 (orifice 50), 64 (orifice 64), 80 (orifice 80) 725 (orifice 50), 928 (orifice 64), 1160 (orifice 80)					
Pressure ¹⁾ p [psig]	1450	1243	1001	510	406	323
Temperature ¹⁾ T [°F]	14 / 392	572	842	950	968	986

¹⁾ Resistance limits for body/cover to EN 1092-1

UNA 38						
End connection	Flange Class 600					
Pressure ¹⁾ p [barg]	100	100	69.9	61.7	59.7	42.5
Temperature ¹⁾ T [°C]	-10 / 20	100	300	400	450	500
Max. allowable differential pressure ΔPMX [psi]	50 (orifice 50), 64 (orifice 64), 80 (orifice 80) 725 (orifice 50), 928 (orifice 64), 1160 (orifice 80)					
Pressure ¹⁾ p [psig]	1450	1450	1014	895	866	616
Temperature ¹⁾ T [°F]	14 / 68	212	572	752	842	932

¹⁾ Resistance limits for body/cover to EN 1759-1

UNA 38 High-temperature						
End connection	Flange PN 100					
Pressure ¹⁾ p [barg]	100	100	100	83.7	51.2	32.4
Temperature ¹⁾ T [°C]	-10 / 20	100	300	450	500	530
Max. allowable differential pressure ΔPMX [psi]	50 (orifice 50), 64 (orifice 64), 80 (orifice 80) 725 (orifice 50), 928 (orifice 64), 1160 (orifice 80)					
Pressure ¹⁾ p [psig]	1450	1450	1450	1214	742	470
Temperature ¹⁾ T [°F]	14 / 68	212	572	842	932	986

¹⁾ Resistance limits for body/cover to EN 1092-1 (≤ 400°C) and to EN 12516-2 (> 450 °C)

UNA 38 High-temperature						
End connection	Socket-weld end, butt-weld ends via transition pieces					
Pressure ¹⁾ p [barg]	100	100	100	83.7	51.2	32.4
Temperature ¹⁾ T [°C]	-10 / 20	100	350	450	500	530
Max. allowable differential pressure ΔPMX [psi]	50 (orifice 50), 64 (orifice 64), 80 (orifice 80) 725 (orifice 50), 928 (orifice 64), 1160 (orifice 80)					
Pressure ¹⁾ p [psig]	1552	1552	1552	1214	742	470
Temperature ¹⁾ T [°F]	14 / 68	212	662	842	932	986

¹⁾ Resistance limits for body/cover to EN 12516-2

UNA 38 High-temperature						
End connection	Flange Class 600					
Pressure ¹⁾ p [barg]	100	100	78.2	67.6	51.2	32.4
Temperature ¹⁾ T [°C]	-10 / 20	100	350	450	500	530
Max. allowable differential pressure ΔPMX [psi]	50 (orifice 50), 64 (orifice 64), 80 (orifice 80) 725 (orifice 50), 928 (orifice 64), 1160 (orifice 80)					
Pressure ¹⁾ p [psig]	1494	1494	1134	980	742	470
Temperature ¹⁾ T [°F]	14 / 68	212	662	842	932	986

¹⁾ Resistance limits for body/cover to EN 1759-1 (≤ 450°C) and to EN 12516-2 (> 500 °C)

Pressure and temperature ratings

UNA 39						
End connection	Flange PN 160, Flange CL 1500					
Pressure ¹⁾ p [barg]	160	134.8	104.3	71.6	46.4	37.3
Temperature ¹⁾ T [°C]	-10 / 300	450	500	520	540	550
Max. allowable differential pressure [barg]	80 (orifice 80), 110 (orifice 110), 140 (orifice 140)					
ΔPMX [psi]	1160 (orifice 80), 1595 (orifice 110), 2030 (orifice 140)					
Pressure ¹⁾ p [psig]	2320	1955	1512	1038	673	541
Temperature ¹⁾ T [°F]	14 / 572	842	932	968	1004	1022

¹⁾ Resistance limits for body/cover to EN 1092-1

UNA 39						
End connection	Socket-weld end, butt-weld end					
Pressure ¹⁾ p [barg]	160	134.8	104.3	71.6	46.4	37.3
Temperature ¹⁾ T [°C]	-10 / 300	450	500	520	540	550
Max. allowable differential pressure [barg]	80 (orifice 80), 110 (orifice 110), 140 (orifice 140)					
ΔPMX [psi]	1160 (orifice 80), 1595 (orifice 110), 2030 (orifice 140)					
Pressure ¹⁾ p [psig]	2320	1955	1512	1038	673	541
Temperature ¹⁾ T [°F]	14 / 572	842	932	968	1004	1022

¹⁾ Resistance limits for body/cover to EN 12516-2

UNA 39						
End connection	Flange Class 900					
Pressure ¹⁾ p [barg]	155	117	84.6	64.5	41.8	33.6
Temperature ¹⁾ T [°C]	-10 / 100	350	500	520	540	550
Max. allowable differential pressure [barg]	80 (orifice 80), 110 (orifice 110), 140 (orifice 140)					
ΔPMX [psi]	1160 (orifice 80), 1595 (orifice 110), 2030 (orifice 140)					
Pressure ¹⁾ p [psig]	2248	1697	1227	935	606	487
Temperature ¹⁾ T [°F]	14 / 212	662	932	968	1004	1022

¹⁾ Resistance limits for body/cover to EN 12516-2

Orifice and differential pressure

Orifice (Ø)	Hole diameter [mm]		Differential pressure ΔPMX [bar]
	UNA 38	UNA 39	
50	2.8	–	50
64	2.3	–	64
80	2	1.9	80
80 MAX	6.5	–	80
110	–	1.6	110
140	–	1.4	140
140 MAX	–	6.5	140

Dimensions and weights

UNA 38		[mm]	15	20	25	40	50
		[inch]	½	¾	1	1½	2
Overall length [mm]	Flange EN / DIN (PN 100)	L	300	300	300	420	416
	Flange to ASME (Class 600)	L	300	300	300	421	427
	Socket-weld end	L	300	300	300	420	420
	Butt-weld end	L	300	300	300	300	300
	Butt-weld ends via transition pieces of 1.7335	L	300	300	300	420	420
Weight	with flange	[kg]	38	38	38	40	42
	with socket-weld, butt-weld, butt-weld ends via transition pieces	[kg]	35	35	35	35	35

Dimensions UNA 38

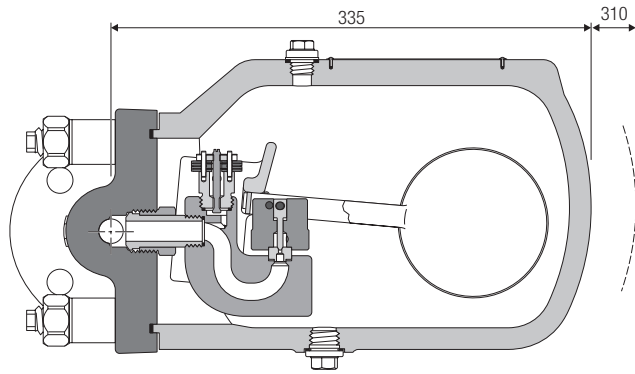

UNA 38h

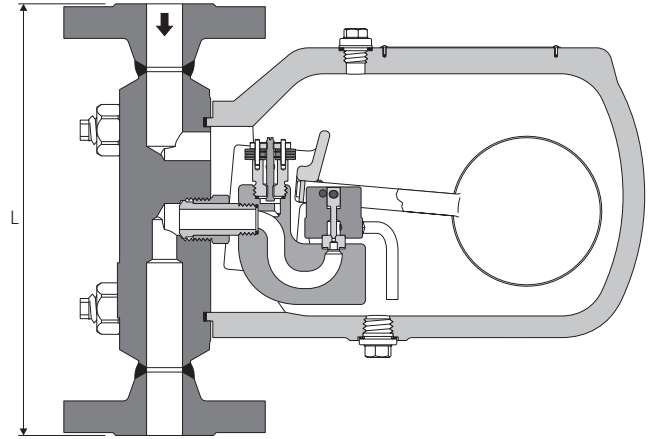

UNA 38v

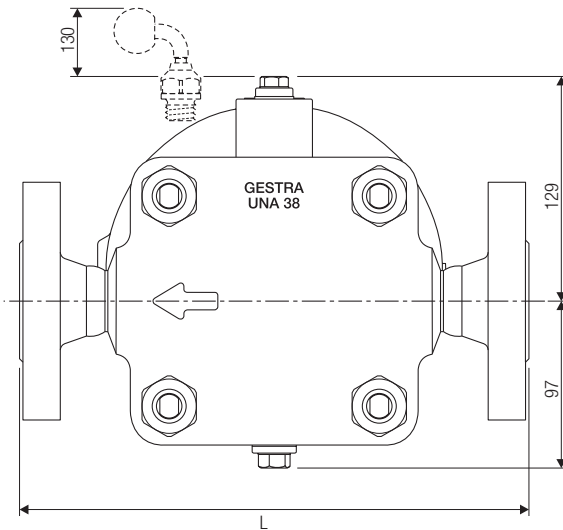

UNA 38h, flow from left to right (viewed from cover end)

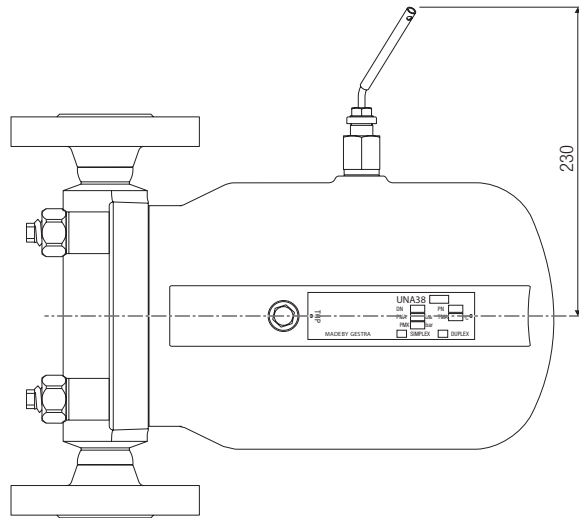

UNA 38h

Dimensions UNA 39

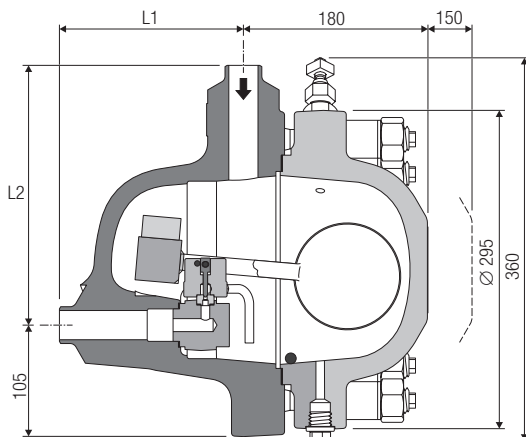

Dimensions and weights

UNA 39		[mm]	15	25	40	50
		[inch]	½	1	1½	2
Length [mm]	Flange to EN / DIN (PN 160)	L1	215	230		245
		L2	285	300		315
	Flange to ASME (Class 900/1500)	L1	240	250		280
		L2	310	320		350
	Socket-weld end	L1	170	170		170/245 ¹⁾
	Butt-weld end	L2	240	240		240/315 ¹⁾
	for pipe		21.3 x 2.0	33.7 x 3.2	48.3 x 3.6	60.3 x 4.0
Weight	with flange	[kg]	67	70		78
	with socket-weld, butt-weld, butt-weld ends via transition pieces	[kg]	65	65		65

¹⁾ Socket-weld/butt-weld

Capacity Charts

The chart shows the maximum capacities for hot condensate for the respective orifice.

The capacities are dependent on the differential pressure (working pressure).

The differential pressure is the difference between inlet and outlet pressure and depends among other things on the run of the condensate line.

If the condensate downstream of the trap is lifted, the differential pressure is reduced by 1 bar for 7 m lift.

The maximum admissible differential pressure is dependent on the cross-sectional area of the orifice and the density of the liquid to be discharged.

The charts show the maximum capacities for hot condensate.

The max. capacity of cold water that the steam trap with control unit SIMPLEX or DUPLEX can discharge is: Capacity multiplied by factor F.

Capacity Charts

UNA 38

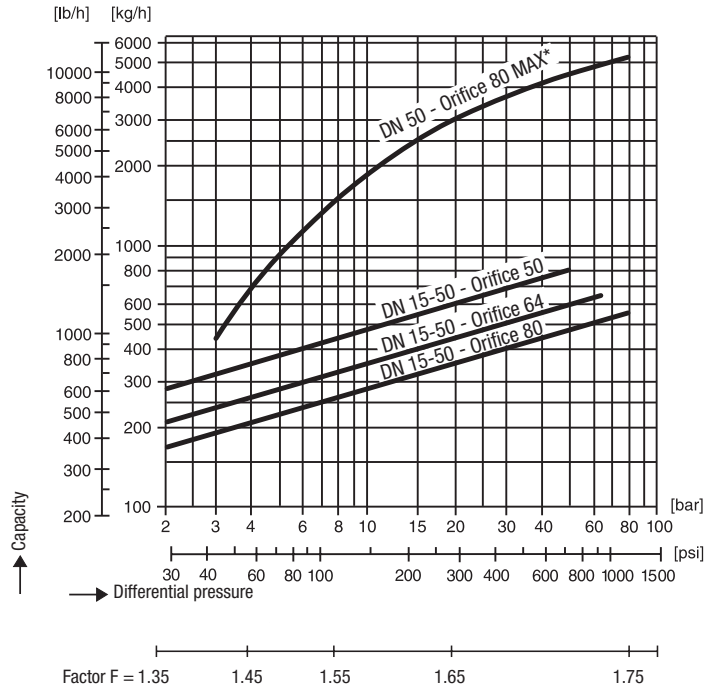

Additional cold-water start-up capacity due to thermostatic capsule DUPLEX design (only UNA 38)

Δp	[barg]	1	2	4	8	12	20	80
Flowrate	approx.kg	180	260	380	560	720	950	2100

UNA 39

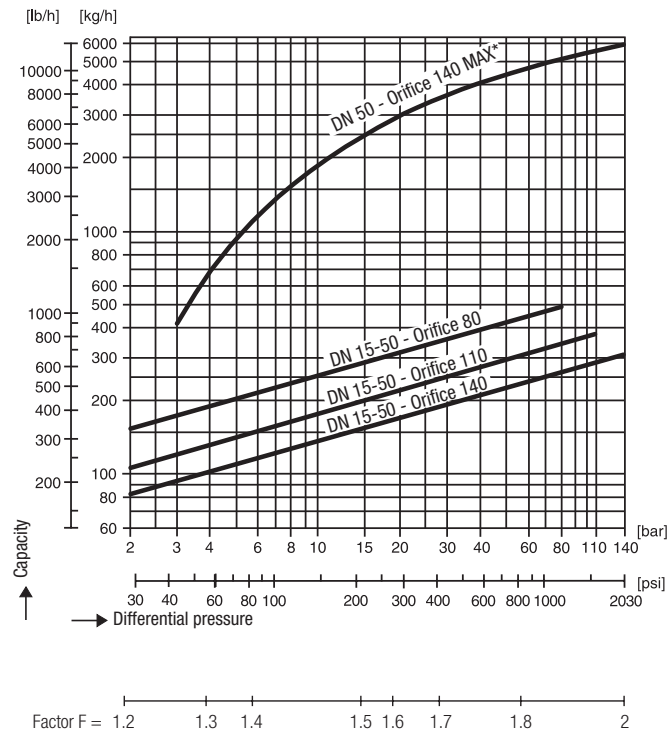

* Note that equipment with smaller end connections does not achieve the indicated flowrates.

Ball Float Steam Trap

UNA 38, PN 100/CL 600, DN 15-50

**UNA 39, PN 160/CL 900/CL 1500,
DN 15-50**

Inspection & Certification

Documentation regarding material tests and in-house examination with test report EN10204 available. All inspection requirements have to be stated with the enquiry or order. After supply of the equipment certification cannot be established. Charges and extent of the above mentioned test certificates as well as the different tests confirmed therein are listed in our Price List "Test and Inspection Charges for Standard Equipment". For other tests and inspections than those listed above, please consult us.

Application of European Directives

Pressure Equipment Directive (PED)

The equipment conforms to this directive and can be used for the following media:

- UNA 38, UNA 39
- Fluids of group 1
- Fluids of group 2

ATEX Directive

The equipment does not have its own potential ignition source and is not subject to this directive.

When installed, static electricity may arise between the equipment and the connected system. When used in potentially explosive atmospheres, the plant manufacturer or plant operator is responsible for discharging or preventing possible static charge.

If it is possible for medium to escape, e.g. through actuating mechanisms or leaks in threaded joints, the plant manufacturer or plant operator must take this into consideration when dividing the area into zones.

Spare parts for UNA 38

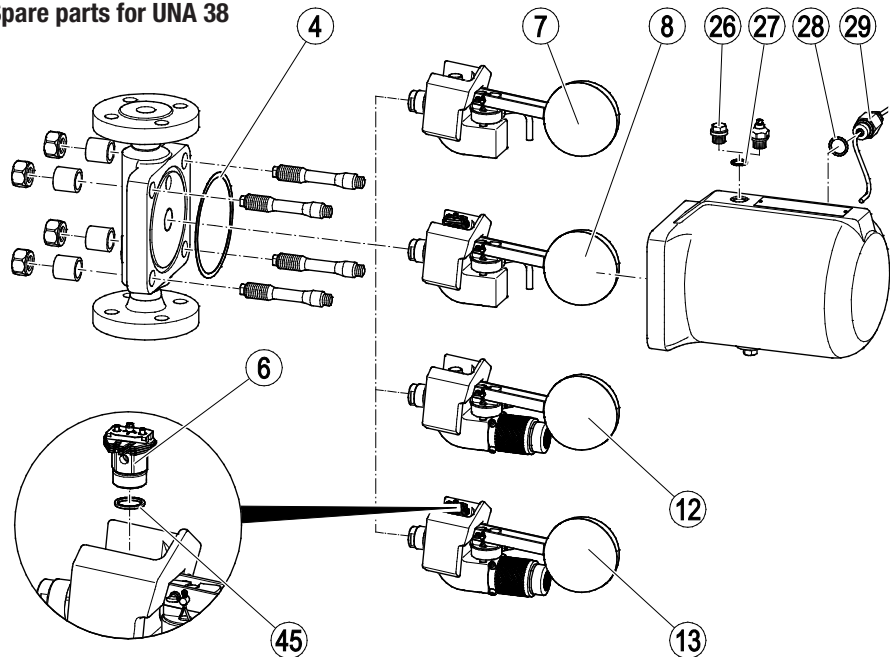

Item no.	Designation	Orifice	Stock code #
4	Body gasket	all	524532
4, 8	Control unit DUPLEX, complete with body gasket	50	560550
		64	560551
		80	560552
4, 13	Control unit DUPLEX Orifice 80 MAX, complete with body gasket	80 MAX	560553
4, 7	Control unit SIMPLEX, complete with body gasket	50	560554
		64	560555
		80	560556
4, 12	Control unit SIMPLEX Orifice 80 MAX, complete with body gasket	80 MAX	560557
26, 27	Hand vent valve, complete with gasket	all	560559
28, 29	Float-lifting lever, complete with gasket	all	560560
6, 45	Bimetallic air vent, compl. with gasket	all	560558

Spare parts UNA 39

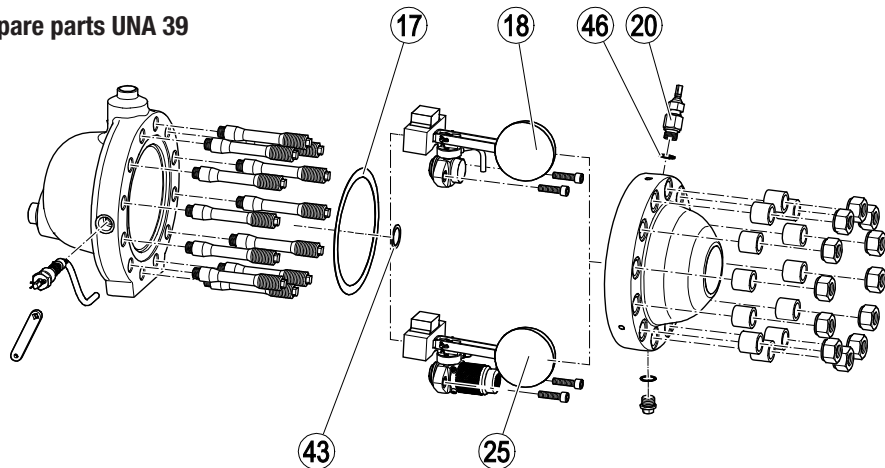

Item no.	Designation	Orifice	Stock code #
17	Body gasket	all	523031
17, 18	Control unit, complete with body gasket	80	560172
		110	560171
		140	560170
17, 25	Control unit, complete with body gasket	140 MAX	560179
20, 46	Hand vent valve, complete with gasket	all	560179
17, 43, -	Gasket kit ¹⁾	all	560539

Supply in accordance with our general terms of business.

¹⁾ Contains: Body gasket (17), gasket for control unit (§§), seat gasket (-)

GESTRA AG

Münchener Straße 77, 28215 Bremen, Germany
 Telefon +49 421 3503-0, Telefax +49 421 3503-393
 E-mail info@de.gestra.com, Web www.gestra.de

