

# STOP GLOBE VALVE TYPE 218

## CHARACTERISTIC:

Diameter	-	10 -300 mm;
Pressure	-	40 bar (flanges may be drilled for PN 6, 10, 16, 25 bar);
Temperature	-	up to 560°C (with PTFE sealing up to ≤ 200°C);
Medium	-	water, steam and other non-toxic, non aggressive liquid and gas media and engine fuel, sea water.

## VERSIONS:

type / ends / body material / disc and disc ring / others/ drive type

Example: 218 / --- / --- / --- / ---

Example: 218 / S / U / R / WM

Ends	Sign	Body material	Sign	Disc and disc ring	Sign	Others	Sign	Drive type	Sign
Standard - flanged	---	(P250GH) C 22.8 or GP240GH	---	Standard	---	Position indicator	X	Hand wheel	---
Butt weld ends	S			PTFE	P			AUMA drive	NA
Socket weld	SW	16Mo3 or G20Mo5	U	NBR	N			NWA drive	NW
Threaded	G	13CrMo4-5 or G17CrMo5-5	A	STELLIT	L			MODACT drive	NM
				Titan	T			Pneumatic drive	NP

## APPLICATION:

Stop globe valve is designed to open and stop the flow. The valve is not supposed to be used as a regulating device.

DN 15 - 50

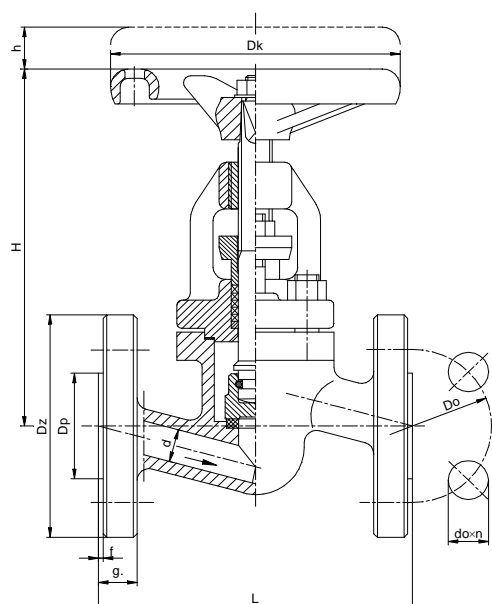

"SW"

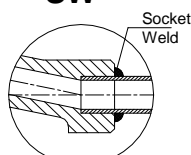

"G"

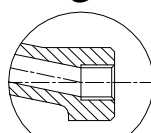

"S"

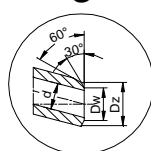

DN 65 - 300

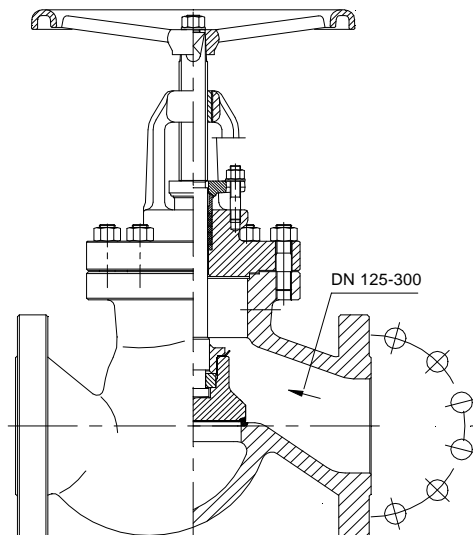

Equilibrating disc DN  
125-300

T<sub>max</sub> 200°C

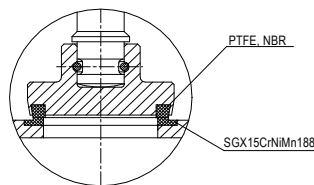
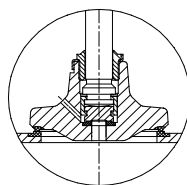

# WK



FABRYKA ARMATURY PRZEMYSŁOWEJ

„WAKMET” spółka jawna

Kaczmarek, Krzywdziński, Wachowski, Wilczyński

Bodzanów 75 48-340 GŁUCHOŁAZY 1

tel. +48(077) 439-40-20, fax +48(077) 439-18-72

e-mail: wakmet@wakmet.com.pl

http: www.wakmet.com.pl

## MATERIALS:

Versions	Standard	U	A	WM	Other versions
<b>Parts</b>	<b>T<sub>MAX</sub> 450°C</b>	<b>T<sub>MAX</sub> 530°C</b>	<b>T<sub>MAX</sub> 560°C</b>	<b>T<sub>MAX</sub> 450°C</b>	-
Body, bonnet DN 15-50	(P250GH) C22.8 (1.0460)	16Mo3 (1.5415)	13CrMo4-5 (1.7335)	(P250GH) C22.8 (1.0460)	(P250GH) C22.8, 16Mo3, 13CrMo4-5
Body, bonnet DN 65-300	<b>T<sub>MAX</sub> 450°C</b> GP240GH (1.0619)	<b>T<sub>MAX</sub> 500°C</b> G20Mo5 (1.5419)	<b>T<sub>MAX</sub> 550°C</b> G17CrMo5-5 (1.7357)	<b>T<sub>MAX</sub> 450°C</b> GP240GH (1.0619)	GP240GH, G20Mo5, G17CrMo5-5
Seat ring DN15-25	X17CrNi16-2				Stellit lub CW306G
Seat ring	G 18 8 Mn(1.4370)				
Disc DN 15-50	X30Cr13 (1.4028)	X30Cr13 (1.4028)	13CrMo4-5 (1.7335)	X17CrNi16-2 (1.4057)	CW306G
Disc DN 65-300	P250GH (1.0460)	P250GH (1.0460)	13CrMo4-5 (1.7335)	P250GH (1.0460)	CW306G
Disc ring	G 18 8 Mn (1.4370)				Stellit lub CW306G lub PTFE lub NBR
Stem	X20Cr13 (1.4021)	X17CrNi16-2 (1.4057)	X39CrMo17-1 (1.4122)	X17CrNi16-2 (1.4057)	BT9 lub CW306G
Packing rings, gasket	Grafit				
Wheel	Cast iron				

Special materials on request; modifications reserved.

## DIMENSIONS:

DN	Standard - flanged												With butt weld ends							
	PN 40												PN 16							
	Dz	Dp	Do	do	n	L	g.	f	H	h	Dk	Weight	Dz	Dp	Do	do	n	Dz	Dw	Weight
15	95	45	65	14	4	130	16	2	155	13	120	3,80	95	45	65	14	4	22	17	2,40
20	105	58	75	14	4	150	18	2	155	13	120	4,50	105	58	75	14	4	28	22	2,50
25	115	68	85	14	4	160	18	2	155	13	120	5,00	115	68	85	14	4	35	28,5	2,80
32	140	78	100	18	4	180	18	2	195	15	160	9,50	140	78	100	18	4	44	37	6,20
40	150	88	110	18	4	200	18	3	205	19	160	10,70	150	88	110	18	4	50	43	5,90
50	165	102	125	18	4	230	20	3	215	24	160	12,80	165	102	125	18	4	62	54	8,10
65	185	122	145	18	8	290	22	3	245	30	200	28,40	185	122	145	18	4	77	69	17,50
80	200	138	160	18	8	310	24	3	300	40	250	36,70	200	138	160	18	8	91	81	23,50
100	235	162	190	22	8	350	24	3	402	45	320	52,50	220	158	180	18	8	117	104	40,80
125	270	188	220	26	8	400	26	3	436	55	280	70,20	250	184	210	18	8	144	130,5	67,70
150	300	218	250	26	8	480	28	3	496	65	320	106,50	285	212	240	22	8	172	156,5	86,60
200	375	285	320	30	12	600	34	3	576	75	400	207,20	340	268	295	22	12	223	204,5	171,40
250	450	345	385	33	12	730	38	3	590	130	400	325,00	405	320	355	26	12	278	256,5	276,60
300	515	410	450	33	16	850	42	3	730	205	600	530,00	460	370	410	26	12	329	306,5	456,00
350	515	410	450	33	16	850	42	4	730	205	600	620,00	520	-	470	26	16	362	336,5	-

Dimensions in mm; modifications reserved.

## TECHNICAL DATA:

Body material	PN	Maximal working pressure at working temperature																		
		20°C	100°C	150°C	200°C	250°C	300°C	350°C	400°C	450°C	500°C	510°C	520°C	530°C	540°C	550°C	560°C			
(P250GH)C 22.8 (1.0460)	40	40,0	40,0	40,0	36,2	32,4	28,6	24,8	20,9	13,1	-	-	-	-	-	-	-	-	-	-
16Mo3 (1.5415)	40	40,0	40,0	40,0	40,0	39,0	34,3	32,4	30,5	29,5	22,4	17,7	14,5	11,2	9,0	-	-	-	-	-
13CrMo4-5 (1.7335)	40	40,0	40,0	40,0	40,0	40,0	39,8	38,1	36,2	34,3	29,3	26,1	22,0	17,9	14,9	11,6	9,3	7,6	-	-
GP240GH (1.0619)	40	40,0	31,6	28,9	26,3	24,1	20,3	25,7	19,5	12,5	-	-	-	-	-	-	-	-	-	-
G20Mo5 (1.5419)	40	40,0	33,2	30,9	28,6	26,7	24,8	23,3	22,5	21,8	16,4	12,8	-	-	-	-	-	-	-	-
G17CrMo5-5 (1.7357)	40	40,0	40,0	40,0	40,0	40,0	40,0	40,0	38,1	27,6	21,5	15,4	13,7	11,9	10,2	8,4	6,7	-	-	-

## MOUNTING AND OPERATING:

*The valve can only be mounted and operated by skilled, properly trained and qualified personnel. Incorrect assembly or operation of the valve may have substantial impact on the entire system such as fluid leakage, reduction in system's function etc.*

Before a valve is installed the pipeline must be clean from any mechanical impurities. The compatibility of critical parameters of the flow must be checked with the parameters of the valve. Stop globe valve can be mounted to a pipe-line in any position. The direction of flow should only comply with the arrow marked on the body. The valve should be operated strictly with its assign. In order to provide valve's reliability the following suggestions must be observed:

- medium flowing through the valve is supposed to be clean out of any mechanical impurities;
- the valve must be protected from any mechanical damages during its work;
- nominal parameters marked on the valve must be observed.