

Pump Trap

UNA 25-PK

Condensate Lifter

UNA 25-PS

EN
English

Original Installation Instructions
818979-04

Contents

Foreword	3
Availability.....	3
Formatting features in the document	3
Safety	3
Use for the intended purpose	3
Basic safety notes	4
Qualification of personnel.....	5
Protective gear	5
Typographic features of warning notes.....	5
Formatting features for warnings of property damage	5
Description	6
Scope of supply and equipment specification	6
Task and function	9
Storing and transporting the equipment	10
Storing the equipment	10
Transporting the equipment	10
Mounting and connecting the equipment	11
Preparing installation	11
Connecting the equipment	11
Operation	14
After operation	14
Removing external dirt deposits.....	14
Maintaining the equipment.....	14
Servicing the equipment and installing spare parts	19
Troubleshooting	22
Putting the equipment out of operation	24
Removing harmful substances.....	24
Removing the equipment	24
Re-using equipment after storage.....	25
Disposing of the equipment.....	25
Technical data	26
Dimensions and weights	26
Pressure & temperature ratings.....	27
Declaration of Conformity – Standards and Directives	27

Foreword

This installation & operating manual will help you use the following types of equipment safely and efficiently for their intended purpose.

- ▶ Pump Trap UNA 25-PK
- ▶ Condensate Lifter UNA 25-PS

These types will be called equipment in this document.

This installation & operating manual is intended for anyone commissioning, using, operating, servicing, cleaning or disposing of this equipment and, in particular, for professional after-sales service technicians, qualified personnel and authorised and trained staff.

All of these persons must read and understand the content of this installation & operating manual.

Following the instructions given in this installation & operating manual helps avoiding danger and increases the reliability and service life of the equipment. Please note that in addition to the instructions given in this installation & operating manual you must also observe all locally applicable rules and regulations concerning the prevention of accidents as well as approved safety guidelines for good professional practice.

Availability

Keep this installation & operating manual together with the plant documentation for future reference. Make sure that this installation & operating manual is available to the operator.

The installation & operating manual is part of the equipment. Please hand over this installation & operating manual when selling the equipment or passing it on.

Formatting features in the document

Certain text elements of this installation & operating manual feature a specific typographic design. You can easily distinguish the following text elements:

Standard text

Cross-reference

- ▶ Listing
 - ▶ Sub-items in listings
- Steps for action.



Here you will find additional useful information and tips serving to assist you in using the equipment to its fullest potential.

Safety

Use for the intended purpose

UNA 25-PS and UNA 25-PK is steam process equipment designed for the effective removal of condensate from steam.

The equipment must only be used within the allowable pressure and temperature limits and only if the chemical and corrosive influences on the equipment are taken into account.

Correct use includes compliance with the instructions given in this installation & operating manual, in particular obedience to all safety instructions.

Any other use of the equipment is considered to be improper.

Note that the equipment is also used incorrectly if the materials of the equipment are not suitable for the fluid.

Basic safety notes

Risk of severe injuries

- ▶ The equipment is under pressure during operation and may be hot. Before carrying out any work on the equipment make sure that the following requirements are met:
 - ▶ The pipes must be depressurized (0 bar).
 - ▶ The fluid must be completely removed from the pipes and the equipment.
 - ▶ During work on the equipment the installation must be switched off and protected against unauthorised or unintended activation.
 - ▶ The pipes and the equipment must have cooled down to room temperature (approx. 20 °C).
- ▶ If the equipment is used in contaminated areas there is a risk of severe injuries or death caused by harmful substances in or on the equipment. Before working on the equipment make sure that it is completely decontaminated. Always wear the protective clothing prescribed for contaminated areas when working on the equipment.
- ▶ The equipment must only be used with fluids that do not attack the material and the gaskets and sealings of the equipment. Otherwise leaks may occur and hot or toxic fluid could escape.
- ▶ The equipment and its component parts must only be mounted or removed by qualified personnel. A qualified person must be acquainted with and experienced in the following:
 - ▶ Making pipe connections.
 - ▶ Selecting suitable lifting gear and understanding the rules for its safe use.
 - ▶ Working with dangerous (contaminated, hot or pressurized) fluids.
- ▶ If the admissible temperature and pressure limits are exceeded the equipment may be destroyed and hot or pressurized fluid may escape. Make sure that the equipment is only operated within the admissible service range and limits.
For more information on limits and pressure &

temperature ratings see name plate and the section "*Technical Data*".

Risk of minor injuries

- ▶ Sharp edges on internals present the danger of cuts to hands. Always wear industrial gloves when servicing the equipment.
- ▶ Do not drop the equipment. If it falls down it may cause bruises and injuries. The equipment does not have fixing points for lifting gear. Note that the position of the equipment is unstable as long as it is not mounted in place. To transport the equipment safely use suitable lifting gear. Connect the noose strap of the lifting gear to the body. Provide sufficient support for the equipment during transport and installation. Wear protective safety footwear.

Information on property damage or malfunctions

- ▶ Malfunctions will occur if the equipment is installed in a wrong position or with the flow arrow pointing in the opposite direction of the fluid flow. This may result in damage to the equipment or the installation. Make sure that the flow arrow on the equipment body matches the indicated direction of the fluid flow in the pipe.
- ▶ If the material is unsuitable for the fluid, increased wear may occur and fluid may escape. Make sure that the material is suitable for the fluid used in your installation.
- ▶ If the equipment is not suited for the service conditions of the plant, it may result in damage and/or failure of the equipment or installation. Make sure that the following conditions are satisfied:
 - ▶ A venting pipe must always be installed.
 - ▶ The steam pressure of the plant must always be higher downstream of the UNA 25 PS than upstream of it.
 - ▶ Observe the required net positive suction head (NPSH).
 - ▶ The condensate line upstream of the equipment must be adequately sized to handle the build up of condensate produced during the pumping process and act as a

reservoir.
Provide a pipe bend right in front of the equipment in order to allow the fluid to back up vertically.

Qualification of personnel

A qualified person must be acquainted with and experienced in the following:

- ▶ the pertinent on-site rules and regulations for preventing fire and explosions as well as industrial safety regulations
- ▶ working on pressure equipment
- ▶ making pipe connections
- ▶ working with dangerous (hot or pressurized) fluids
- ▶ lifting and transporting loads
- ▶ observing all notes and instructions in this installation & operating manual and the applicable documents

Protective gear

The required protective gear depends on the types of fluid used and the regulations on site. For more information on suitable protective clothing and safety gear refer to the safety data sheet of the fluid in question.

Protective gear comprises the following items:

- ▶ Safety helmet to EN 397
- ▶ Safety footwear to EN ISO 20345
- ▶ Protective leather gloves to EN 388

Wear some form of ear protection to EN 352 when standing close to the equipment (1 m or less) during operation.

Typographic features of warning notes



DANGER

Notes with the heading DANGER warn against imminent dangerous situations that can lead to death or serious injuries.



WARNING

Notes with the heading WARNING warn against possibly dangerous situations that could lead to death or serious injuries.



CAUTION

Notes with the heading CAUTION warn against dangerous situations that could lead to minor or moderate injuries.

Formatting features for warnings of property damage

Attention!

This information warns of a situation leading to property damage.

Description

Scope of supply and equipment specification

Scope of supply

Our equipment is delivered packed and ready for assembly.

Equipment specification

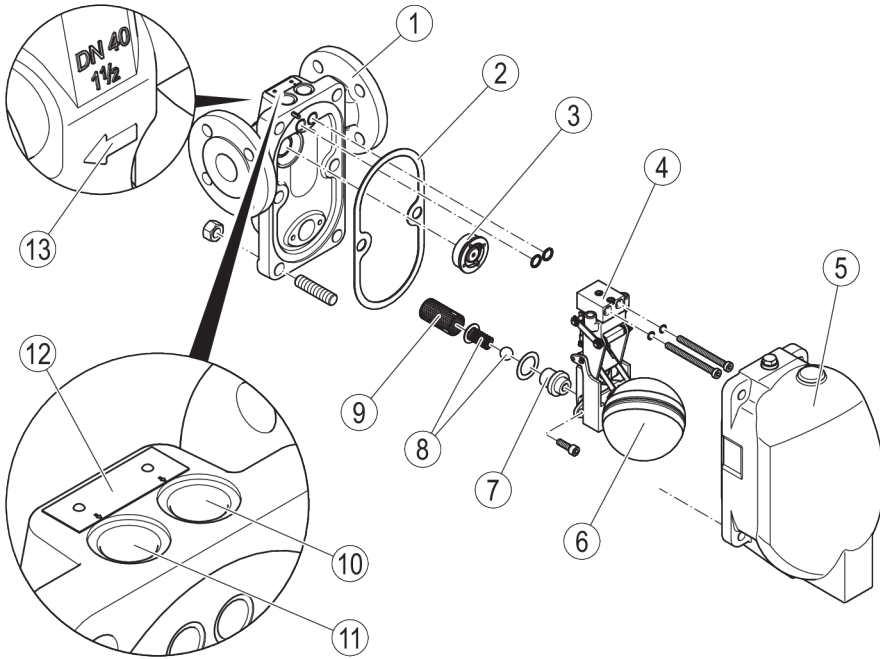

No.	Designation
1	Body
2	Gasket
3	Inlet non-return valve
4	Control unit (here: UNA 25-PK)
5	Cover
6	Float
7	Orifice (O, for UNA 25-PK) (for UNA 25-PS: seat)

No.	Designation
8	Outlet non-return valve
9	Anti-wear element
10	Connection for motive steam line
11	Connection for vent line
12	Name plate
13	Flow arrow

Control unit

The types UNA 25-PK and UNA 25-PS differ only in their control units:

The control unit of the UNA 25-PK is equipped with a lightweight float. This float controls the condensate discharge via the connected counter-balance weight and changeover linkage fitted with a rolling ball.

The control unit of the UNA 25-PS is equipped with a standard float. This float controls the condensate discharge via the connected immersion tube.

UNA 25-PK

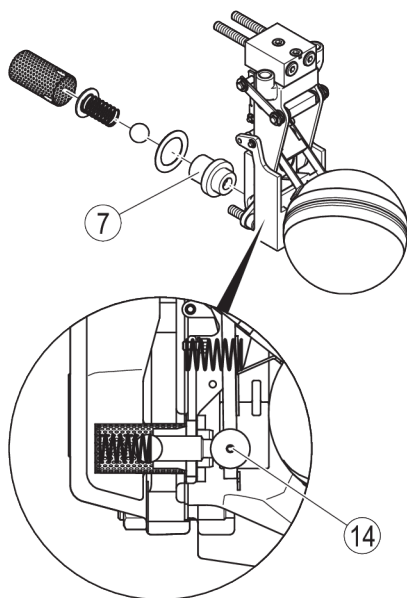

UNA 25-PS

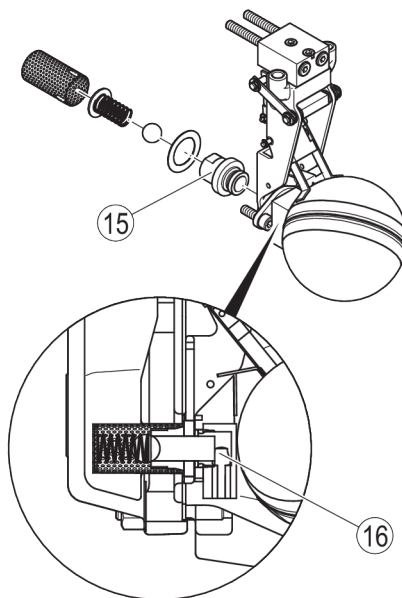

No.	Designation
7	Orifice (UNA 25-PK)
14	Changeover linkage with rolling ball
15	Seat (UNA 25-PS)
16	Immersion tube

Optional extras

The following items are available as optional extra:

- Hand vent valve

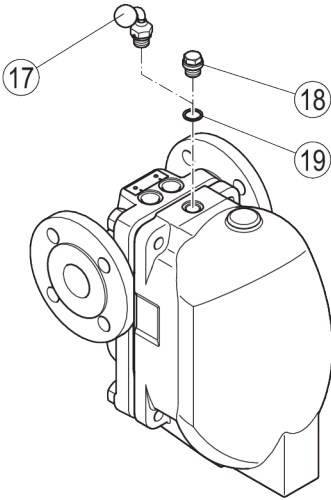

No.	Designation
17	Hand vent valve
18	Sealing plug
19	Gasket

End connections

The equipment is available with the following end connections:

- Flanges
- Screwed sockets
- Pipe thread

Name plate/identification

The following items are indicated on the name plate:

- Manufacturer
- Type designation
- Pressure rating
- Max. service temperature
- Max. service pressure
- Max. admissible back pressure
- Mark (if required), e. g. CE, UKCA, EAC

The following items are indicated on the equipment body:

- Nominal size
- Material
- Direction of flow
- Date of manufacturing

Application of European Directives

Fluids

The equipment is designed for the following fluids (in accordance with the EU Pressure Equipment Directive or Pressure Equipment (Safety) Regulations in the UK):

- Fluids of group 2

Due consideration must be given to chemical and corrosive influences.

Potentially explosive atmospheres

The equipment does not have its own potential source of ignition (as per ATEX Directive). Please pay attention to the following information:

When installed, static electricity may arise between the equipment and the connected system.

When used in potentially explosive atmospheres, the plant manufacturer or plant operator is responsible for discharging or preventing possible static charge.

If it is possible for medium to escape, e.g. through actuating mechanisms or leaks in threaded joints, the plant manufacturer or plant operator must take this into consideration when dividing the area into zones.

Task and function

Purpose

UNA 25-PS and UNA 25-PK is steam process equipment designed for the effective removal of condensate from steam.

Condensate is discharged by means of motive steam.

The equipment can therefore remove condensate even if the steam pressure is so low that conventional steam traps could no longer discharge condensate.

Equipment type UNA 25-PS works as cyclic condensate lifter without valve closure. In this case the upstream pressure must be lower than the back pressure.

Equipment type UNA 25-PK works in pumping mode as cyclic condensate lifter with rolling ball valve closure.

If there is (enough) differential pressure, this type of equipment will also work as modulating steam trap.

Function UNA 25-PS

Condensate enters the trap body and causes the float to rise.

Once the upper tripping point is reached the float operates the valve control linkage which in turn opens the motive steam inlet and closes the vent valve.

The motive steam forces the condensate through the immersion tube out of the trap body. As the condensate level falls, the float sinks.

During this pumping process condensate collects in the supply line.

As soon as the float has reached its lower tripping point, the valve control linkage closes the motive steam inlet and opens the vent valve.

Condensate flows into the trap body and a new cycle begins.

The gas-tight non-return valve prevents backflow of condensate or motive steam through the condensate inlet. The spring-loaded ball in the outlet prevents backflow at the condensate outlet.

Function UNA 25-PK

If the differential pressure is sufficient, equipment type UNA 25-PK works in continuous trapping mode with leakproof rolling ball valve closure. If the differential pressure is too low, the equipment works as cyclic condensate lifter.

If the upstream pressure of the condensate is higher than the back pressure, UNA 25-PK works in normal operating mode.

Condensate enters the trap body and causes the float to rise.

The float moves the rolling ball, thereby opening the orifice (O). An open orifice allows the condensate to be drained continuously. The vent valve is now open.

As the condensate level falls within the trap body, the float sinks and, by closing the orifice, provides a leakproof seal.

If the upstream pressure of the condensate is lower than the back pressure, condensate cannot drain. The condensate level within the trap body rises. The float is lifted until it reaches its upper tripping point for the valve control linkage.

The control linkage opens the motive steam inlet and closes the vent valve.

The equipment works now as cyclic condensate lifter. This function is described in the section on the UNA 25-PS.

Storing and transporting the equipment



CAUTION

Do not drop the equipment. If it falls down it may cause bruises and injuries.

- To transport and mount the equipment safely use suitable lifting gear.
- Connect the noose strap of the lifting gear to the body.
- Provide sufficient support for the equipment during transport and installation.
- Wear protective safety footwear.

Attention!

Equipment can be damaged if stored or transported improperly.

- Close all openings with the sealing plugs or covers supplied with the equipment or use similar sealing covers.
- Protect the equipment against moisture and corrosive atmospheres.
- Please contact the manufacturer if the specified transport and/or storage requirements cannot be met.

Storing the equipment

- Please observe the following items when storing the equipment:
 - Do not store the equipment for more than 12 months.
 - Use the supplied sealing plugs or other suitable seal caps in order to seal off all openings of the equipment.
 - Protect the sealing surfaces and contact areas against mechanical damage.
 - Protect the equipment and all components against hard shocks and impacts.
 - Store the equipment only in closed rooms that meet the following environmental conditions:
 - Air humidity below 50 %, not condensing

- Indoor air: clean, salt-free and non-corrosive
- Temperature 5–40 °C.

- Make sure that all these requirements are always met when storing the equipment.
- Please contact the manufacturer if you cannot comply with the recommended storage conditions.

Transporting the equipment

- Meet the requirements for storage also when transporting the equipment.
- Prior to transport seal off connections with sealing plugs.



If you do not have the sealing plugs supplied with the equipment use appropriate seal caps to seal off the connections.

- For short distances (only a few metres) you can transport the equipment unpacked.
- When transporting the equipment over larger distances use the original packaging.
- If you do not have the original packaging use a box that protects the equipment adequately against corrosion and physical damage.



For a short period of time the equipment may be transported even if the temperature is below 0 °C, provided that the equipment is completely empty and dry.

Mounting and connecting the equipment

Preparing installation

- Take the equipment out of the transport packaging.
- Check the equipment for transport damage.
- Contact the manufacturer if you detect any kind of shipping damage.

When supplied by the factory, the connections may be sealed off with sealing plugs.

- Remove sealing plugs before mounting the equipment.
- Keep the sealing plugs and the packing for further use.

Install the equipment only in horizontal pipelines.



DANGER

Personnel working on pipes are exposed to safety risks and may suffer severe injuries, poisoning or even loss of life.

- Make sure that no hot or hazardous fluid is in the equipment or the pipes.
- Make sure that the pipes upstream and downstream of the equipment are depressurised.
- Make sure that the installation is switched off and protected against unauthorised or unintended activation.
- Make sure that the equipment and the pipes have cooled down to room temperatures.
- Wear protective clothing that is suitable for the fluid and, if necessary, wear protective gear.

For more information on suitable protective clothing and safety gear refer to the safety data sheet of the fluid in question.

- Drain pipes until they are empty.
- Make sure that all pipelines upstream and downstream of the equipment are depressurised.

- Switch the installation off and protect it against unauthorised or unintended re-activation.

Connecting the equipment



DANGER

Incorrectly connected equipment can result in accidents with extremely severe injuries or death.

- Make sure that only specialist personnel connect the equipment to the pipe.
- Make sure that the direction of flow in the pipe matches the flow direction arrow on the equipment.
- Make sure that the connected pipe does not subject the body to any stress (forces or torques) during installation and operation.

Specialist personnel must have knowledge and experience of the type of pipe connection used.



CAUTION

Do not drop the equipment. If it falls down it may cause bruises and injuries.

- To transport and mount the equipment safely use suitable lifting gear.
- Connect the noose strap of the lifting gear to the body.
- Provide sufficient support for the equipment during transport and installation.
- Wear protective safety footwear.

Attention!

Equipment will be damaged if the end connections are undersized.

- Make sure that the connections are strong and rigid enough to support the weight of the equipment and to withstand the forces that occur during operation.

To allow easy access for routine servicing and exchanging components observe the indicated withdrawal distance of 200 mm from the cover to adjacent installation parts.

- Make sure that the pipe system of the plant is clean.
- Make sure that the equipment is free from foreign matter.
- Mount the equipment in the desired installation position.

To connect the equipment you will need the following tools:

- ◆ Combination spanner A. F. 22, DIN 3113, form B
- ◆ Torque spanner (US: wrench) 20–120 Nm, DIN ISO 6789
- Make sure the motive steam and vent lines satisfy the following conditions:
 - ◆ Use the metal sealing rings in the screw-in threads. Do not use hemp or PTFE tape.
 - ◆ Lines must be routed such as to avoid water pockets.
 - ◆ Lines must have a minimum cross-section of DN15 (½ inch).

- ◆ With UNA 25 PK equipment, a vent line must be installed. Discharging into the atmosphere will lead to malfunctions.
- Make sure the condensate supply and condensate outflow lines satisfy the following conditions:
 - ◆ The minimum inlet height must be complied with. At maximum motive steam pressure and a back pressure of 1 barg, the inlet height must be 0.5 m minimum.
 - ◆ The condensate line upstream of the equipment must be adequately sized to handle the build up of condensate produced during the pumping process and act as a reservoir.
 - ◆ With UNA 25 PS equipment, the upstream pressure must be lower than the downstream pressure. Otherwise, live steam leakage may occur.
- If you are unable to satisfy one or more of these requirements, please contact the manufacturer.

It is recommended that the motive steam line is fitted with a strainer and a pressure gauge.

- Seal off the lines with a G ½ threaded coupling on the body.
- Connect the body to the pipework as shown in the following drawing.

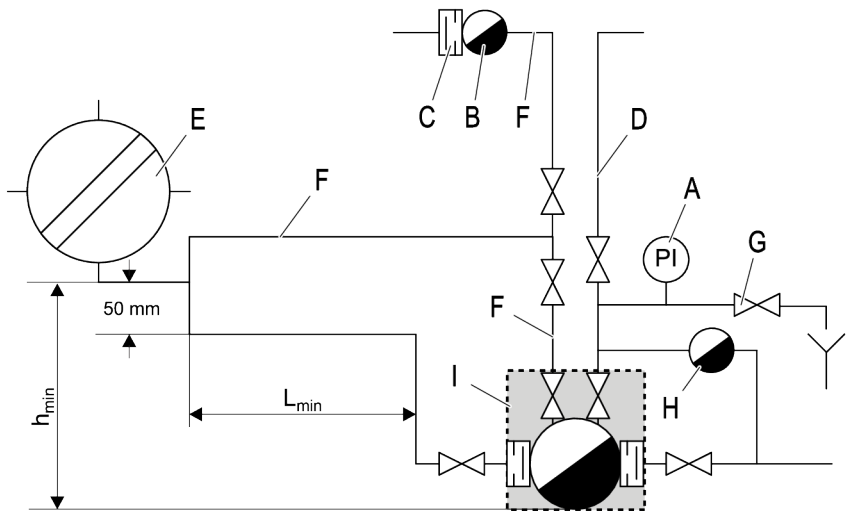

A	Pressure gauge
B	Thermostatic steam trap, e. g. MK, for venting
C	Optional non-return valve in order to prevent air from entering if a vacuum is formed.
D	Motive steam line (drained, DN 15)

E	Heat exchanger
F	Vent line, size DN15
G	Pressure relief valve
H	Thermostatic steam trap for draining motive steam line, e.g. BK
I	UNA 25-PK/ UNA 25-PS

L_{min} 2.5 m, DN40

h_{min} 0.5 m

- Make sure that the equipment is safely mounted and that all connections are made correctly.

Operation

Do not work on the equipment while it is operating.

The optional hand vent valve allows manual gas venting.

- To vent gas or air open the hand vent valve.
- Close the hand vent valve fingertight after venting.

After operation



DANGER

If fluid escapes personnel may suffer severe injuries, poisoning or even loss of life.

- After working on the equipment make sure that all connections and valves are tight.
- Make sure that the gaskets of the body are leakproof.



DANGER

If the equipment is used in contaminated areas there is a risk of severe injuries or death caused by harmful substances in or on the equipment.

- Only qualified personnel are allowed to perform work on contaminated equipment.
- Always wear the protective clothing prescribed for contaminated areas when working on the equipment.
- Make sure that the equipment is completely decontaminated before carrying out any service work.
- Follow the pertinent instructions for handling the hazardous substances in question.

Attention!

Frost damage may occur when the installation is shut down.

- Drain the equipment if ambient temperatures below 0 °C (frost) are to be expected.

Removing external dirt deposits

- To remove dirt deposits rinse the equipment with fresh water and wipe it with a clean, lint-free cloth.
- To remove any persistent residues use a cleaning agent that is suitable for the material and carefully wipe the equipment with a clean, lint-free cloth.

Maintaining the equipment



DANGER

Personnel working on pipes are exposed to safety risks and may suffer severe injuries, poisoning or even loss of life.

- Make sure that no hot or hazardous fluid is in the equipment or the pipes.
- Make sure that the pipes upstream and downstream of the equipment are depressurised.
- Make sure that the installation is switched off and protected against unauthorised or unintended activation.
- Make sure that the equipment and the pipes have cooled down to room temperatures.
- Wear protective clothing that is suitable for the fluid and, if necessary, wear protective gear.

For more information on suitable protective clothing and safety gear refer to the safety data sheet of the fluid in question.

For work on the equipment you will need the following tools:

- ▶ Combination spanner A. F. 17, DIN 3113, form B
- ▶ Combination spanner A. F. 19, DIN 3113, form B
- ▶ Combination spanner A. F. 22, DIN 3113, form B
- ▶ Combination spanner A. F. 24, DIN 3113, form B
- ▶ Torque spanner (US: wrench) 10-60 Nm, DIN ISO 6789
- ▶ Torque spanner (US: wrench) 60-120 Nm, DIN ISO 6789
- ▶ Torque spanner (US: wrench) 120–300 Nm, DIN ISO 6789
- ▶ Key for hexagon socket screws A.F. 5, DIN ISO 2936
- ▶ Key for hexagon socket screws A.F. 6, DIN ISO 2936
- ▶ Key for hexagon socket screws A.F. 10, DIN ISO 2936
- ▶ Screwdriver 5.5/125, DIN 5265
- ▶ Adjustable pin spanner (US: wrench) for 2 hole nuts, cranked, pin diameter 4 mm

i Malfunctions may occur if the equipment is used with different types of condensate: The following condensates in particular cause problems:

- ▶ very oily condensates
- ▶ condensates that resinify or become gummy
- ▶ condensates that recrystallize
- ▶ condensates that contain solid matter.

In these cases check the equipment at regular intervals for contamination and, if necessary, remove dirt deposits.

To reduce contamination we recommend installing a sedimentation vessel or a dirt pocket arrangement upstream of the equipment.

Normally you do not have to clean the internal parts of the equipment.

To clean the equipment completely take off the cover and remove the control unit.

i The following drawings show equipment type UNA 25-PK.

Removing cover

- ▶ Unscrew hexagon nuts (29) off the stud bolts (28) on the body.
- ▶ Lift the cover (5) off the body (1).
- ▶ Remove the gasket (2).
- ▶ For the disposal of the gasket observe the pertinent on-site regulations concerning waste disposal.

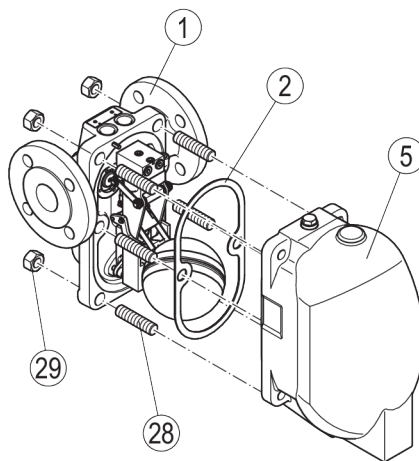

Removing control unit

- Take the cover off the body as described from page 15 onwards.
- Loosen the socket-head cap screws (25).
- Loosen the socket-head cap screws (26).
- Remove the gaskets (24).
- Remove the control unit (4) together with the orifice / seat (7) from the body.
- Remove the gaskets (20).

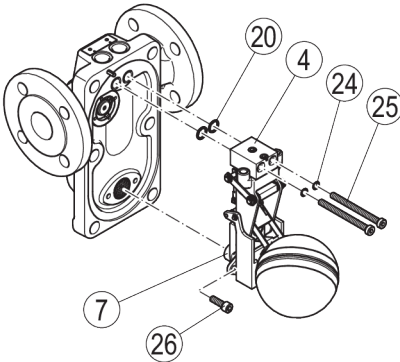

- **i** If Loctite 62 was used to fix the gasket in place, completely remove all Loctite 62 residues from the body and gasket.

- Remove the gasket (23) from the non-return valve.
- Take the orifice or the seat (7) off the body.
- Pull the ball (22) and the spring (21) of the non-return valve out of the anti-wear element (9).

- **i** The anti-wear element (9) is permanently fixed to the body and cannot be removed.

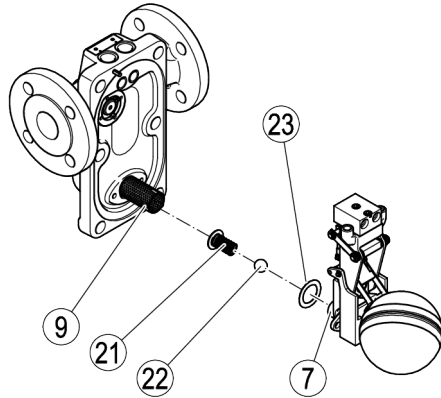

- For the disposal of the gaskets observe the pertinent on-site regulations concerning waste disposal.

Cleaning the equipment

Check the equipment at regular intervals for contamination. The intervals depend on the amount of dirt in the system. The operator must determine the maintenance intervals.

- To remove dirt deposits rinse the equipment with fresh water and wipe it with a clean, lint-free cloth.
- To remove any persistent residues use a cleaning agent that is suitable for the material and carefully wipe the equipment with a clean, lint-free cloth.
- Remove any parts that are dirty and cannot be cleaned properly.

To clean the inside of the equipment proceed as follows:

- Take the cover off the body as described from page 15 onwards.
- Remove the control unit as described from page 16 onwards.
- To remove dirt deposits rinse the equipment with fresh water and wipe it with a clean, lint-free cloth.
- To remove any persistent residues use a cleaning agent that is suitable for the material and carefully wipe the equipment with a clean, lint-free cloth.
- Attach the control unit to the body as described from page 17 onwards.
- Attach the control unit to the body as described from page 18 onwards.

Mounting the control unit

- Check all removed parts for signs of damage.
- Replace all worn or damaged parts.
- Clean all dirty parts.
- Apply high-resistant lubricant to all threads, bearing faces of screws, nuts and bolts.

The lubricant must have the same properties as OKS® 217.

- Replace all gaskets with new ones of the same type.
- Put the spring (21) and the ball (22) of the non-return valve into the anti-wear element (9).
- Insert a new gasket (23) for the seat (7) in the non-return valve.

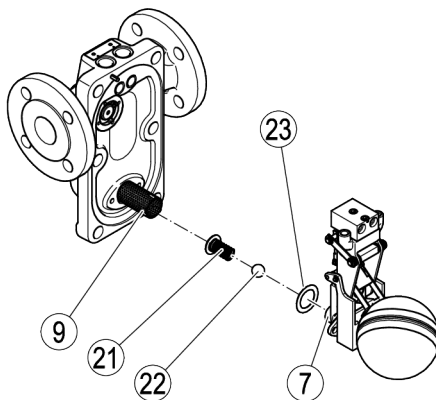

i The seat of the UNA 25-PS is screwed together with the immersion tube.

- To fix the seat in place screw it into the immersion tube, applying a torque of 75 Nm.

The closing unit (orifice) of the UNA 25-PK is plugged into the control unit and therefore no screwed union is required.

The seats of the UNA 25-PS and UNA 25-PK are fixed in different ways.

The closing unit (orifice) of the UNA 25-PK is inserted into the body and fixed in place by the integrated control unit.

The seat of the UNA 25-PS is screwed together with the immersion tube. For more information on how to fix the seat and immersion tube refer to section "*Exchanging the control unit*" on page 20.

- Attach the orifice or the seat (7) to the non-return valve.

i If Loctite 62 was used to fix the gasket that you removed in place, apply Loctite 62 (or a similar glue) to the body and the new gasket.

- Insert the new gaskets (20) and (24) into the control unit.
- Fix the control unit in place using the socket-head cap screws (25) and (26).
- Tighten the socket-head cap screws (25) with a torque of 20 Nm.
- Tighten the socket-head cap screws (26) with a torque of 10 Nm.

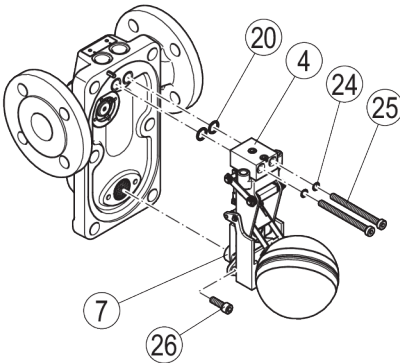

- Attach the control unit to the body as described from page 18 onwards.

Mounting cover

Attention!

Equipment may leak if the gasket is damaged.

- It is therefore essential that you always insert a new gasket before re-attaching the cover.
 - Make sure that the cover is not tilted or skewed when refitted.
-
- Clean the gasket surfaces of the cover and body.
 - Apply heat-resistant lubricant (OKS® 217) to the threads and the gasket faces of the stud bolts.
 - Put a new gasket (2) onto the body (1).
 - Insert the four stud bolts (28) into the bores of the body.
 - Put the cover (5) as shown onto the body.
 - Insert hexagon nuts (29) on both ends of the four stud bolts (28).
 - Tighten the hexagon nuts evenly in diagonally opposite pairs to a torque of 115 Nm.

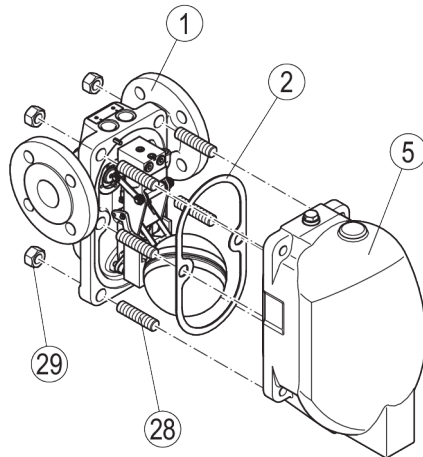

Servicing the equipment and installing spare parts

You may exchange the following component parts in case of wear or damage:

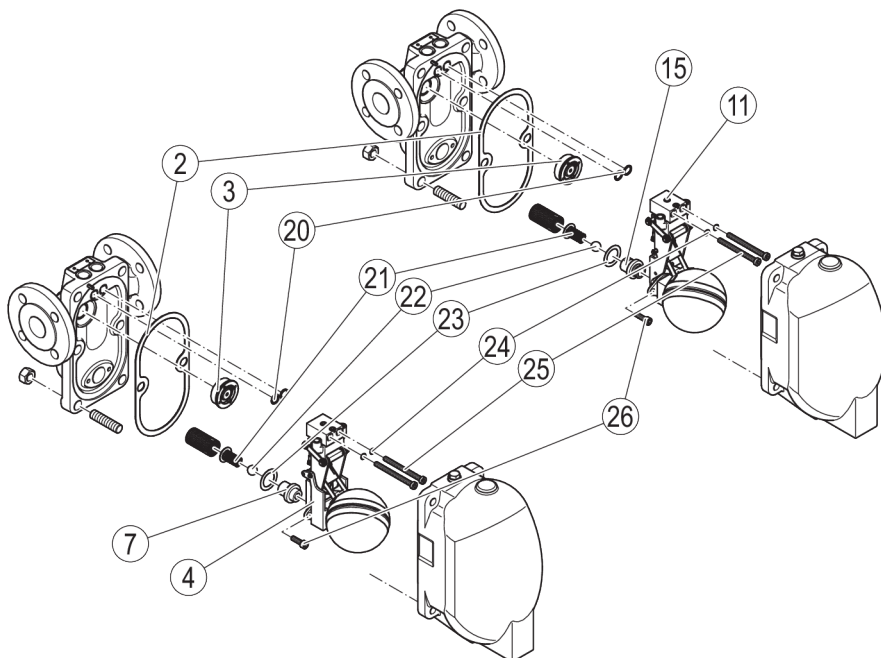

No.	Designation	Order number	
		UNA 25-PK	UNA 25-PS
2, 4, 20, 23, 24, 25, 26	Control unit UNA 25-PK, AO 6, complete	560593	–
	Control unit UNA 25-PK, AO 13, complete	560624	–
2, 11, 20, 23, 24, 25, 26	Control unit UNA 25-PS, complete	–	560594
2, 3, 20, 23, 24, 25, 26	Inlet non-return valve	560595	
2, 7, 20, 21, 22, 23, 24, 25, 26	Outlet non-return valve, UNA 25-PK, AO 6, complete	560597	–
	Non-return valve UNA 25-PK, AO 13, complete	560625	–
2, 15, 20, 21, 22, 23, 24, 25, 26	Outlet non-return valve, UNA 25-PS, complete	–	560598

Exchanging the control unit

- Take the cover off the body as described from page 15 onwards.
- Remove the control unit as described from page 16 onwards.

The immersion tube for UNA 25-PS is not a spare part. You have to remove the immersion tube from the old control unit and install it in the new one.

- Unscrew the seat (15) from the immersion tube (16).
- Detach the immersion tube from the old control unit (11).
- Attach the immersion tube to the new control unit.
- Screw the seat with a torque of 75 Nm to the immersion tube.

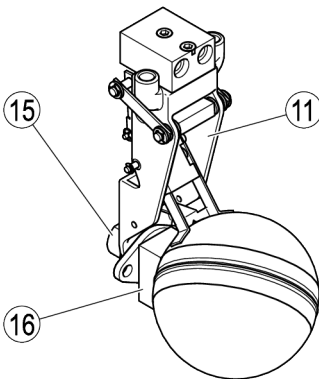

- Attach the control unit to the body as described from page 17 onwards.
- Attach the control unit to the body as described from page 18 onwards.

Replacing outlet non-return valve

- Take the cover off the body as described from page 15 onwards.
- Replace any damaged parts of the non-return valve.
- Attach the control unit to the body as described from page 17 onwards.
- Attach the control unit to the body as described from page 18 onwards.

Replacing inlet non-return valve

- Take the cover off the body as described from page 15 onwards.
- Remove the control unit as described from page 16 onwards.
- Insert a pin spanner (US: wrench) for 2 holes (30) into the bores in the inlet non-return valve (3).
- Detach the inlet non-return valve.
- Screw the new inlet non-return valve to the body with a torque of 55 Nm.

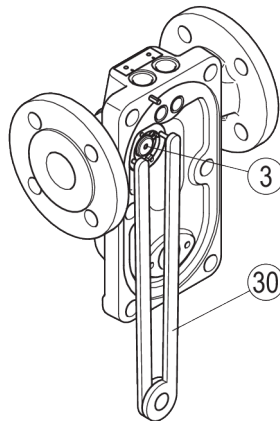

- Attach the control unit to the body as described from page 17 onwards.
- Attach the control unit to the body as described from page 18 onwards.

Exchanging the hand-vent valve



The hand vent valve is an optional extra for all types of equipment.

The hand vent valve can only be installed to equipment with a special cover for fitting such a valve.

- Unscrew the hand vent valve or the sealing plug off the bore.



Danger

Fluid may escape if connections are leaking or sealing rings are damaged.

- Insert a new gasket before re-installation.
 - Use the sealing plug to close the vent hole if you do not mount the hand vent valve.
-
- Insert a new gasket into the bore.
 - Screw the hand vent valve or the sealing plug hand tight into the bore.
 - Tighten the hand vent valve or the sealing plug to a torque of 75 Nm.

Troubleshooting

Problem	Cause	Remedy
<p>Insufficient condensate discharge.</p> <p>Insufficient thermal output of the user.</p> <p>The steam trap is cold or only hand-hot.</p> <p>The equipment is in pumping mode despite sufficient differential pressure (only UNA 25-PK).</p>	The shut-off valves for condensate inlet or outlet are closed.	Open the shut-off valves.
	The condensate inlet or outlet or the orifice is/are dirty.	<p>Clean the pipes.</p> <p>Clean the equipment.</p> <p>Clean the control unit.</p> <p>If necessary, replace the control unit.</p> <p>Clean the orifice.</p>
	The steam trap is undersized.	<p>Use a steam trap with a larger condensate discharge capacity.</p> <p>Mount two traps in parallel.</p>
The steam trap is cold or only hand-hot.	The shut-off valves for condensate inlet or outlet are closed.	Open the shut-off valves.
	The condensate inlet or outlet is dirt clogged.	<p>Clean the pipes.</p> <p>Clean the equipment.</p>
The steam trap is blowing off live steam.	There are dirt deposits in the equipment.	<p>Clean the equipment.</p> <p>Replace the control unit.</p>
	The control unit is worn.	Replace the control unit.
Condensate does not flow into the equipment.	The shut-off valves for condensate inlet or outlet are closed.	Open the shut-off valves.
	The shut-off valve in the deaeration line is closed.	
	The inlet non-return valve is blocked or defective.	Replace the inlet non-return valve.
	The pressure in the deaeration line is too high.	Connect the deaeration line according to the wiring diagram shown in the data sheet.

Problem	Cause	Remedy
Fluid escapes (equipment is leaking).	The end connections are not tight.	Seal off the end connections (e. g. flanged or screwed ends).
	A gasket on the body is defective.	Replace the gasket with a new one.
	The body has been damaged by corrosion or erosion.	Check the resistance of the material for the fluid used. Use a steam trap made from a material that is suitable for the fluid used.
	The equipment has been damaged by frost.	Replace the equipment with a new one. When shutting down the installation make sure that the condensate lines and the steam trap are completely drained.
	The equipment has been damaged by waterhammer.	Replace the equipment with a new one. Take appropriate measures to protect the equipment against waterhammer, e. g. by installing suitable non-return valves.

- If faults occur that are not listed above or cannot be corrected, please contact our Technical Service or authorized agency in your country.

Putting the equipment out of operation

Removing harmful substances



DANGER

If the equipment is used in contaminated areas there is a risk of severe injuries or death caused by harmful substances in or on the equipment.

- Only qualified personnel are allowed to perform work on contaminated equipment.
- Always wear the protective clothing prescribed for contaminated areas when working on the equipment.
- Make sure that the equipment is completely decontaminated before carrying out any service work.
- Follow the pertinent instructions for handling the hazardous substances in question.

Qualified personnel must have extensive experience with and a working knowledge of:

- pertinent rules and regulations concerning handling hazardous substances
- special regulations for handling the hazardous substances encountered on site
- using the required personal protective equipment (PPE) and clothing



CAUTION

Environmental damage may be caused by poisonous fluid residues.

- Before disposing of the equipment make sure that it is clean and free of fluid residues.
- For the disposal of all materials observe the pertinent legal regulations concerning waste disposal.

- Remove all residues from the equipment.

- For the disposal of all residues observe the pertinent legal regulations concerning waste disposal.

Removing the equipment



DANGER

Personnel working on pipes are exposed to safety risks and may suffer severe injuries, poisoning or even loss of life.

- Make sure that no hot or hazardous fluid is in the equipment or the pipes.
- Make sure that the pipes upstream and downstream of the equipment are depressurised.
- Make sure that the installation is switched off and protected against unauthorised or unintended activation.
- Make sure that the equipment and the pipes have cooled down to room temperatures.
- Wear protective clothing that is suitable for the fluid and, if necessary, wear protective gear.

For more information on suitable protective clothing and safety gear refer to the safety data sheet of the fluid in question.

- Make sure that all pipelines upstream and downstream of the equipment are depressurised.



CAUTION

Risk of injuries if the equipment falls down.

- When removing the equipment make sure the it is safely held in place and cannot fall down.

Suitable measures are for instance:

- Equipment that is not too heavy may be supported by a second person.
- For heavy equipment use suitable lifting equipment of sufficient strength.

- Detach the end connections of the equipment from the pipes.
- Put the equipment onto a suitable base.
- Store the equipment as described on page 10.

Re-using equipment after storage

Observe the following instructions if you want to remove the equipment and use it again somewhere else:

- ◆ Make sure that the equipment is free of any fluid residues.
- ◆ Make sure that all connections are in good condition and leak-free.
- ◆ If necessary re-work welded connections in order to ensure that they are in good working condition.
- Use the equipment only for its intended purpose and the service conditions for which it was specified.

Disposing of the equipment



CAUTION

Environmental damage may be caused by poisonous fluid residues.

- Before disposing of the equipment make sure that it is clean and free of fluid residues.
- For the disposal of all materials observe the pertinent legal regulations concerning waste disposal.

The equipment is made from the following materials:

Component	EN number	ASTM ¹
Body	EN-JS 1049	A 395
Cover	EN-JS-1049	A 395
Internals	Stainless steel	

- 1 Physical and chemical properties comply with EN grade. ASTM nearest equivalent grade is stated for guidance only.

Technical data

Dimensions and weights

	End connection	
Overall length [mm]	Flansch EN	230
	Screwed sockets G, NPT, Flange Class 150	227
Width B [mm]	(all)	325
Space required for servicing S [mm]		200
Total height H [mm]		318 ¹
Weight [kg]	Flanges	31
	Screwed sockets G, NPT	26

1 If equipped with hand-vent valve add 38 mm.

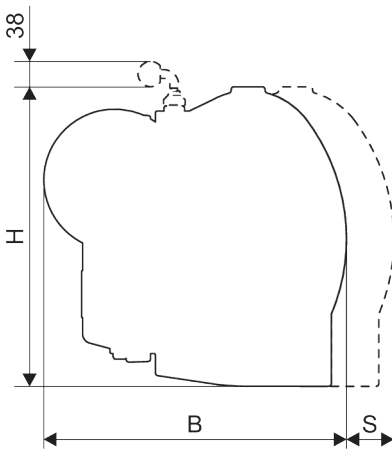

Pressure & temperature ratings

Pressure/temperature limits for flange PN 40 to EN 1092-2, screwed ends G to EN ISO 228-1, 1½, screwed sockets NPT to ASME B1.20.1, 1½				
p (pressure) [bar]	40.0	38.3	31.6	25.0
T (temperature) [°C]	20	120	250	350

Pressure/temperature limits for flange Class 150 to ASME B16.5				
p (pressure) [bar]	17.2	13.9	12.1	6.6
T (temperature) [°C]	20	200	250	350

Motive steam pressure, differential pressure and back pressure		
	UNA 25-PK	UNA 25-PK UNA 25-PS
Max. motive steam pressure and differential pressure Δ PMX [bar]	6	13
Max. operating back pressure P _{MOB} [bar]	3	5

Declaration of Conformity – Standards and Directives

You can find details on the conformity of the equipment and the applicable standards and directives in the Declaration of Conformity and the relevant certificates.

You can download the latest Declaration of Conformity at www.gestra.com. You can request the relevant certificates by writing to the following address:

GESTRA AG

Münchener Straße 77

28215 Bremen

Germany

Phone +49 421 3503-0

Fax +49 421 3503-393

e-mail info@de.gestra.com

Web www.gestra.com

Modifications to the equipment not approved by us will invalidate the Declaration of Conformity and the certificates.



You can find our authorized agents around the world at: www.gestra.com

GESTRA AG

Münchener Strasse 77
28215 Bremen
Germany

Phone +49 421 3503-0
Fax +49 421 3503-393
e-mail info@de.gestra.com
Web www.gestra.com

UK Importer

GESTRA UK Ltd

Unit 1 Sopwith Park, Royce Close,
West Portway Business Park, Andover,
Hampshire SP10 3TS
United Kingdom

818979-04/05-2022_kx_mm [uk] (808831-05) © GESTRA AG Bremen Printed in Germany