

Ball Float Steam Trap

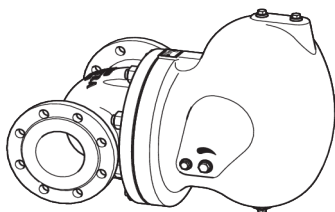

**UNA 43**

**PN 16/CL 125/JIS 10K**

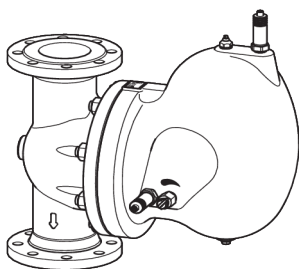

**UNA 46**

**PN 40/CL 150/CL 300/**

**JIS 10K/JIS 20K**

# Contents

<b>Foreword</b> .....	<b>3</b>
Availability.....	3
Formatting features in the document .....	3
<b>Safety</b> .....	<b>3</b>
Use for the intended purpose .....	3
Basic safety notes .....	4
Information on property damage or malfunctions .....	4
Qualification of personnel.....	5
Protective gear .....	5
Typographic features of warning notes.....	5
Formatting features for warnings of property damage .....	5
<b>Description</b> .....	<b>5</b>
Scope of supply and equipment specification .....	5
Task and function .....	9
<b>Storing and transporting the equipment</b> .....	<b>10</b>
Storing the equipment .....	10
Transporting the equipment .....	10
<b>Mounting and connecting the equipment</b> .....	<b>11</b>
Preparing installation .....	11
Orientation of the equipment .....	11
Connecting the equipment .....	12
<b>Operation</b> .....	<b>14</b>
<b>After operation</b> .....	<b>15</b>
Removing external dirt deposits .....	16
Maintaining the equipment.....	16
Servicing the equipment and installing spare parts .....	20
<b>Troubleshooting</b> .....	<b>24</b>
<b>Putting the equipment out of operation</b> .....	<b>26</b>
Removing harmful substances.....	26
Removing the equipment .....	26
Re-using equipment after storage.....	27
Disposing of the equipment.....	28
<b>Technical data</b> .....	<b>29</b>
Dimensions and weights .....	29
Pressure & temperature ratings.....	33
<b>Declaration of Conformity – Standards and Directives</b> .....	<b>34</b>

## Foreword

This installation & operating manual will help you use the following types of equipment safely and efficiently for their intended purpose.

- ▶ UNA 43
- ▶ UNA 46

These types will be called equipment in this document.

This installation & operating manual is intended for anyone commissioning, using, operating, servicing, cleaning or disposing of this equipment and, in particular, for professional after-sales service technicians, qualified personnel and authorised and trained staff.

All of these persons must read and understand the content of this installation & operating manual.

Following the instructions given in this installation & operating manual helps avoiding danger and increases the reliability and service life of the equipment. Please note that in addition to the instructions given in this installation & operating manual you must also observe all locally applicable rules and regulations concerning the prevention of accidents as well as approved safety guidelines for good professional practice.

## Availability

Keep this installation & operating manual together with the plant documentation for future reference. Make sure that this installation & operating manual is available to the operator.

The installation & operating manual is part of the equipment. Please hand over this installation & operating manual when selling the equipment or passing it on.

## Formatting features in the document

Certain text elements of this installation & operating manual feature a specific typographic design. You can easily distinguish the following text elements:

Standard text

*Cross-reference*

- ▶ Listing
  - ▶ Sub-items in listings
- Steps for action.



Here you will find additional useful information and tips serving to assist you in using the equipment to its fullest potential.

## Safety

### Use for the intended purpose

Steam traps type UNA 43 and UNA 46 are designed for draining condensate from steam systems.

Steam traps type UNA 43 can also be used for removing condensate from compressed air systems.

Steam traps type UNA 46 can also be used for removing condensate from gases or gas mixtures.

The equipment must only be used within the allowable pressure and temperature limits and only if the chemical and corrosive influences on the equipment are taken into account.

On type UNA 45, UNA 46 and UNA 46A models with DUPLEX control unit and control membrane, the superheated steam on the control membrane must not exceed 5 K.

Correct use includes compliance with the instructions given in this installation & operating manual, in particular obedience to all safety instructions.

Any other use of the equipment is considered to be improper.

Note that the equipment is also used incorrectly if the materials of the equipment are not suitable for the fluid.

## Basic safety notes

### Risk of severe injuries

- ▶ The equipment is under pressure during operation and may be hot. Before carrying out any work on the equipment make sure that the following requirements are met:
  - ▶ The pipes must be depressurized (0 bar).
  - ▶ The fluid must be completely removed from the pipes and the equipment.
  - ▶ During work on the equipment the installation must be switched off and protected against unauthorised or unintended activation.
  - ▶ The pipes and the equipment must have cooled down to room temperature (approx. 20 °C).
- ▶ If the equipment is used in contaminated areas there is a risk of severe injuries or death caused by harmful substances in or on the equipment. Before working on the equipment make sure that it is completely decontaminated. Always wear the protective clothing prescribed for contaminated areas when working on the equipment.
- ▶ The equipment must only be used with fluids that do not attack the material and the gaskets and sealings of the equipment. Otherwise leaks may occur and hot or toxic fluid could escape.
- ▶ The equipment and its component parts must only be mounted or removed by qualified personnel. A qualified person must be acquainted with and experienced in the following:
  - ▶ Making pipe connections.
  - ▶ Selecting suitable lifting gear and understanding the rules for its safe use.
  - ▶ Working with dangerous (contaminated, hot or pressurized) fluids.
- ▶ If the admissible operating limits are exceeded, the equipment may be destroyed and hot or pressurised medium may escape. Make sure

that the equipment is always used within the admissible operating limits. You can find information on the operating limits in the "*Technical data*" section.

- ▶ If unsuitable lifting gear is used or the gear is used improperly the equipment or parts of it could fall down.
  - ▶ Make sure that only qualified personnel lifts the equipment or parts of it.
  - ▶ Make sure that nobody is standing or working below the hoisted equipment.
  - ▶ Make sure that the lifting gear is of sufficient strength for the load to be hoisted and that the load is properly secured and attached to it. For more information on the nature and weight of the components and safe lifting points please contact the manufacturer.
  - ▶ Make sure that all locally applicable regulations on safety and the prevention of accidents are strictly adhered to.

### Risk of minor injuries

- ▶ Sharp edges on internals present the danger of cuts to hands. Always wear industrial gloves when servicing the equipment.
- ▶ If the support of the equipment during installation is insufficient the equipment might fall down, thereby causing bruises or injuries. Make sure the equipment is safely held in place during installation and cannot fall down. Wear protective safety footwear.

### Information on property damage or malfunctions

- ▶ Malfunctions will occur if the equipment is installed in a wrong position or with the flow arrow pointing in the opposite direction of the fluid flow. This may result in damage to the equipment or the installation. Make sure that the flow arrow on the equipment body matches the indicated direction of the fluid flow in the pipe.
- ▶ If the material is unsuitable for the fluid, increased wear may occur and fluid may escape. Make sure that the material is suitable for the fluid used in your installation.

## Qualification of personnel

A qualified person must be acquainted with and experienced in the following:

- ▶ the pertinent on-site rules and regulations for preventing fire and explosions as well as industrial safety regulations
- ▶ working on pressure equipment
- ▶ making pipe connections
- ▶ working with dangerous (hot or pressurized) fluids
- ▶ lifting and transporting loads
- ▶ observing all notes and instructions in this installation & operating manual and the applicable documents

## Protective gear

The operator must ensure that anyone working on the equipment must wear the required protective clothing and safety gear stipulated for the site of installation. The protective clothing must be suitable for the used media and must protect the wearer against safety and health hazards associated with a particular job to be carried out at the site of installation. Protective clothing & equipment must provide protection from potential hazards, in particular from injuries to:

- ▶ Head
- ▶ Eyes
- ▶ Body
- ▶ Hand
- ▶ Feet
- ▶ Hearing

Note that this list is not exhaustive. The operator must establish personal protective equipment guidelines and specify any additional protective gear that is required if the worker is exposed to a specific risk at the site of installation.

## Typographic features of warning notes



### **DANGER**

Notes with the heading **DANGER** warn against imminent dangerous situations that can lead to death or serious injuries.



### **WARNING**

Notes with the heading **WARNING** warn against possibly dangerous situations that could lead to death or serious injuries.



### **CAUTION**

Notes with the heading **CAUTION** warn against dangerous situations that could lead to minor or moderate injuries.

## Formatting features for warnings of property damage

### ***Attention!***

This information warns of a situation leading to property damage.

## Description

### **Scope of supply and equipment specification**

#### **Scope of supply**

Our equipment is delivered packed and ready for assembly.

## Component parts

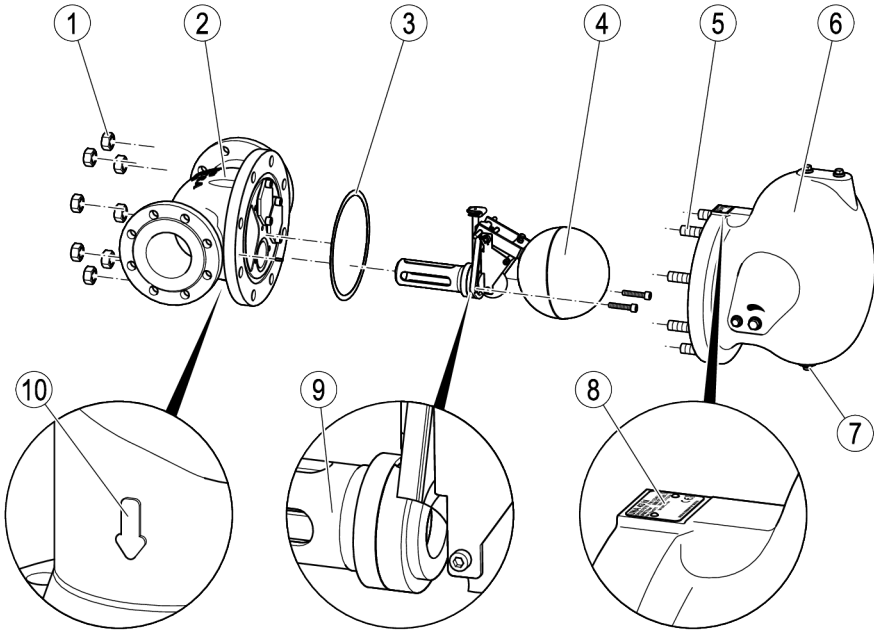

Item no.	Designation
1	Hexagon nuts
2	Body
3	Body gasket
4	Control unit DUPLEX
5	Stud bolts

Item no.	Designation
6	Cover
7	Drain with sealing plug
8	Name plate
9	Adapter
10	Direction of flow arrow

## Optional extras

The following items are available as optional extra:

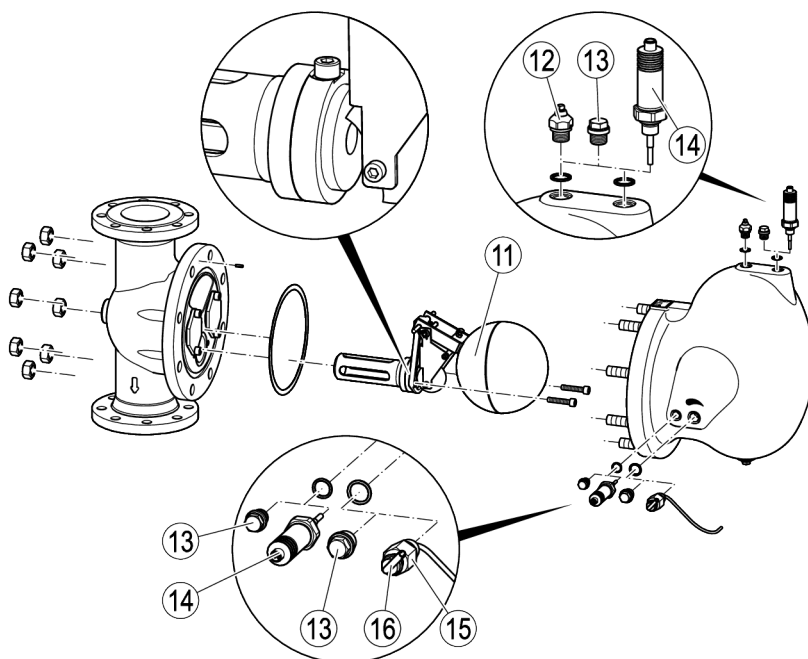

Item no.	Designation
11	Control unit SIMPLEX
12	Hand-vent valve with socket spanner (socket spanner not shown) The vent hole in the cover for the hand-vent valve can also be used for connecting a balance line.

Item no.	Designation
13	Sealing plug
14	Electrodes NRG 16-19 or NRG 16-27
15	Manual float-lifting lever
16	Lever extension

**i** In equipment with control unit SIMPLEX the hand-vent valve is included as standard.

**i** If you want to mount the optional level indicator please contact the manufacturer and refer to the installation and operating manual for the level indicator.

The different equipment versions allow you to adjust the flow direction of the equipment to the flow pattern of your installation. The flow arrow must correspond to the direction of the fluid flow. The following positions of installation are possible:

- ▶ "v" for installation in vertical pipework with downward flow
- ▶ "hl" for flow from right to left (when viewed from the body end)
- ▶ "hr" for flow from left to right (when viewed from the body end)

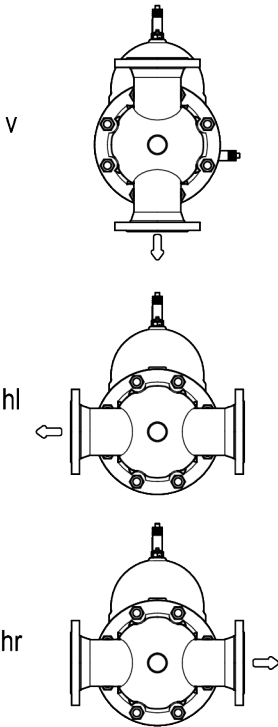

**Name plate/identification**

The indications on the name plates vary according to the equipment type.

The name plate may specify the following:

- ▶ Manufacturer
- ▶ Type designation
- ▶ Design
- ▶ Nominal size
- ▶ Pressure rating
- ▶ Design pressure
- ▶ Design temperature
- ▶ Max. service temperature
- ▶ Max. admissible differential pressure
- ▶ Material number
- ▶ Mark (if required), e. g. CE, UKCA, EAC
- ▶ Date of manufacturing

The following items are indicated on the equipment body:

- ▶ Material
- ▶ Identification marking of material testing
- ▶ Batch code
- ▶ Direction of flow

The following items are indicated on the end connections:

- ▶ Flange face type (RJ number)

**End connections**

The equipment is available with the following end connections:

- ▶ Flanges



## Application of European Directives

### Fluids

The equipment is designed for the following fluids (in accordance with the EU Pressure Equipment Directive or Pressure Equipment (Safety) Regulations in the UK):

#### UNA 43

- ▶ Fluids of group 2

#### UNA 46

- ▶ Fluids of group 1
- ▶ Fluids of group 2

Due consideration must be given to chemical and corrosive influences.

### Potentially explosive atmospheres

The equipment does not have its own potential source of ignition (as per ATEX Directive). Please pay attention to the following information:

When installed, static electricity may arise between the equipment and the connected system.

When used in potentially explosive atmospheres, the plant manufacturer or plant operator is responsible for discharging or preventing possible static charge.

If it is possible for medium to escape, e.g. through actuating mechanisms or leaks in threaded joints, the plant manufacturer or plant operator must take this into consideration when dividing the area into zones.

## Task and function

### Purpose

UNA 43-PS and UNA 46-PK is steam process equipment designed for the effective removal of condensate from steam systems.

Steam traps type UNA 43 can also be used for removing condensate from compressed air systems.

Steam traps type UNA 46 can also be used for removing condensate from gases or gas mixtures.

### Function

A ball float opens the orifice as a function of the liquid level. A rising level results in a proportional opening of the equipment. The max. discharge capacity depends on the orifice size when the ball is completely lifted off its seat and the orifice is fully open.

Equipment with control unit SIMPLEX is particularly suitable for cold condensates and superheated steam.

Equipment with control unit DUPLEX may also be used for air venting the installation. The control unit DUPLEX consists of a float operated rolling ball valve mechanism and, in addition, a temperature dependent air-venting facility. Air venting is controlled by the membrane regulator. Equipment with this type of control unit is particularly suitable for saturated steam systems.

Do not expose the membrane regulator capsule of the DUPLEX control unit to superheat conditions above 5 K.

The optional hand-vent valve attached to equipment with control unit SIMPLEX allows you to manually air vent pipes.

## Storing and transporting the equipment

### **Attention!**

Equipment can be damaged if stored or transported improperly.

- Close all openings with the sealing plugs or covers supplied with the equipment or use similar sealing covers.
- Protect the equipment against moisture and corrosive atmospheres.
- Please contact the manufacturer if the specified transport and/or storage requirements cannot be met.

## Storing the equipment

- Please observe the following items when storing the equipment:
  - ▶ Do not store the equipment for more than 12 months.
  - ▶ Use the supplied sealing plugs or other suitable seal caps in order to seal off all openings of the equipment.
  - ▶ Protect the sealing surfaces and contact areas against mechanical damage.
  - ▶ Protect the equipment and all components against hard shocks and impacts.
  - ▶ Store the equipment only in closed rooms that meet the following environmental conditions:
    - ▶ Air humidity below 50 %, not condensing
    - ▶ Indoor air: clean, salt-free and non-corrosive
    - ▶ Temperature 5–40 °C.
- Make sure that all these requirements are always met when storing the equipment.
- Please contact the manufacturer if you cannot comply with the recommended storage conditions.

## Transporting the equipment



### **CAUTION**

Do not drop the equipment. If it falls down it may cause bruises and injuries.

- To transport and mount the equipment safely use suitable lifting gear.
  - Connect the noose strap of the lifting gear to the body.
  - Provide sufficient support for the equipment during transport and installation.
  - Wear protective safety footwear.
- 
- Meet the requirements for storage also when transporting the equipment.
  - Prior to transport seal off connections with sealing plugs.
- i** If you do not have the sealing plugs supplied with the equipment use appropriate seal caps to seal off the connections.
- For short distances (only a few metres) you can transport the equipment unpacked.
  - When transporting the equipment over larger distances use the original packaging.
  - If you do not have the original packaging use a box that protects the equipment adequately against corrosion and physical damage.
- i** For a short period of time the equipment may be transported even if the temperature is below 0 °C, provided that the equipment is completely empty and dry.

## Mounting and connecting the equipment

### Preparing installation

- Take the equipment out of the transport packaging.
- Check the equipment for transport damage.
- Contact the manufacturer if you detect any kind of shipping damage.

When supplied by the factory, the connections may be sealed off with sealing plugs.

- Remove sealing plugs before mounting the equipment.
- Keep the sealing plugs and the packing for further use.



### DANGER

Personnel working on pipes are exposed to safety risks and may suffer severe injuries, poisoning or even loss of life.

- Make sure that no hot or hazardous fluid is in the equipment or the pipes.
- Make sure that the pipes upstream and downstream of the equipment are depressurised.
- Make sure that the installation is switched off and protected against unauthorised or unintended activation.
- Make sure that the equipment and the pipes have cooled down to room temperatures.
- Wear protective clothing that is suitable for the fluid and, if necessary, wear protective gear.

For more information on suitable protective clothing and safety gear refer to the safety data sheet of the fluid in question.

- Drain pipes until they are empty.
- Make sure that all pipelines upstream and downstream of the equipment are depressurised.

- Switch the installation off and protect it against unauthorised or unintended re-activation.



Malfunctions may occur if the equipment is used with different types of condensate:

The following condensates in particular cause problems:

- very oily condensates
- condensates that resinify or become gummy
- condensates that recrystallize
- condensates that contain solid matter.

In these cases check the equipment at regular intervals for contamination and, if necessary, remove dirt deposits.

To reduce contamination we recommend installing a sedimentation vessel or a dirt pocket arrangement upstream of the equipment.

### Orientation of the equipment

The different equipment versions allow you to adjust the flow direction of the equipment to the flow pattern of your installation. The following positions of installation are possible:

- ▶ with horizontal connections "hl" and "hr" for installation in horizontal pipes
- ▶ with vertical connections "v" for installation in vertical pipework with downward flow

### Attention!

Malfunctions may occur if the control unit is installed incorrectly.

- When installing the equipment make sure that the name plate points upwards and the float arm is free to move up and down.
- Make sure that the flow arrow on the equipment body matches the direction of flow in the pipe.

To avoid malfunctions make sure the following requirements are met when mounting the equipment:

- ▶ The flow arrow on the equipment body must match the fluid flow direction.
- ▶ The name plate on the cover must point upwards.
- ▶ Contact the manufacturer if you want to mount the equipment in a different position of installation.
- ▶ Remove the cover from the body as described in the section "*Removing cover*" from page 16.
- ▶ Remove the control unit as described in the section "*Removing control unit*" on page 17.

The equipment has three connections where the control unit can be fitted. Two connections are sealed with a blind flange. The control unit is attached to the third connection. To change the flow direction you have to reposition the control unit to the lower connection. To do so proceed as follows:

- ▶ Turn the body by 90° or 180° into the desired position of installation.
- ▶ Remove the socket-head cap screws at the lower blind flange on the body.
- ▶ Remove the blind flange.
- ▶ Secure the control unit to the body as described in the section "*Mounting the control unit*" from page 18.
- ▶ Make sure that the opening of the air vent at the orifice points upwards.
- ▶ Make sure that the float arm is free to move up and down.
- ▶ Make sure that the flow arrow on the equipment body matches the flow direction of the fluid.
- ▶ Use the two socket-head cap screws to attach the blind flange to the open connection on top of the body.
- ▶ Tighten the two socket-head cap screws with a torque of 30 Nm.
- ▶ Attach the cover to the body as described in the section "*Mounting cover*" from page 19.

To prevent ordering the wrong type when replacing the equipment note the modification you made on the name plate.

- ▶ Change the type marking according to the actual flow direction.
- ▶ Obliterate the stock code number as to make it indecipherable .

## Connecting the equipment



Depending on the purpose of usage you may insulate the equipment.

- ▶ For more information please contact the manufacturer.



### DANGER

Incorrectly connected equipment can result in accidents with extremely severe injuries or death.

- ▶ Make sure that only specialist personnel connect the equipment to the pipe.
- ▶ Make sure that the direction of flow in the pipe matches the flow direction arrow on the equipment.
- ▶ Make sure that the connected pipe does not subject the body to any stress (forces or torques) during installation and operation.

Specialist personnel must have knowledge and experience of the type of pipe connection used.



### CAUTION

Do not drop the equipment. If it falls down it may cause bruises and injuries.

- ▶ To transport and mount the equipment safely use suitable lifting gear.
- ▶ Connect the noose strap of the lifting gear to the body.
- ▶ Provide sufficient support for the equipment during transport and installation.
- ▶ Wear protective safety footwear.

---

### **Attention!**

Equipment will be damaged if the end connections are undersized.

- Make sure that the connections are strong and rigid enough to support the weight of the equipment and to withstand the forces that occur during operation.

---

Consider space required for servicing the equipment and/or exchanging components and observe the necessary withdrawal distance to remove the cover. For more information on the required withdrawal distances see section "*Dimensions and weights*" on page 29.



Some applications require that the equipment is fitted with an air-balance pipe: float traps for compressed air line drainage and equipment installed in plants where condensate is lifted upstream of the equipment.

- In this case connect the air balance pipe to the bore on top of the cover.
- Make sure that the pipe system of the plant is clean.
- Make sure that the equipment is free from foreign matter.

---

### **Attention!**

Malfunctions may occur if the equipment is installed incorrectly.

- The equipment must be installed with the inlet end at the top and with the float arm in a horizontal plane so that it rises and falls vertically.

- 
- Install the equipment in the desired, permitted installation position.
  - Make sure that the pipes meet the following requirements:
    - ◆ The layout of the pipelines must prevent the formation of water pockets.
    - ◆ The pipeline must have a gradient so that the condensate is free to fall towards the equipment

- ◆ The cross section of the air balance pipe must be at least DN 8 (¼ ") .
- ◆ If the equipment is fitted with control unit SIMPLEX, an air balance pipe must be connected to the vent hole for the hand-vent valve. The balance line must have a ¾ " BSP end connection.
- If one or more of the above mentioned requirements cannot be met, please contact our Technical Service or authorized agency in your country.
- Connect the end connections of the equipment properly to the pipes.
- If necessary, connect the air balance pipe to the equipment as shown in the following drawing.

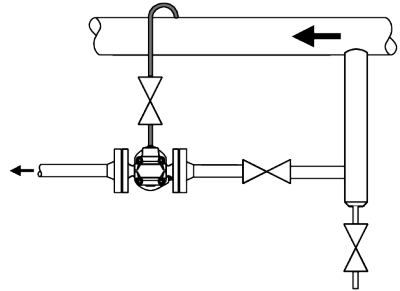

- Make sure that the equipment is safely mounted and that all connections are made correctly.

## Mounting the measuring electrode

You can attach one or two measuring electrodes (14) of the following type:

- ▶ To detect banking-up of condensate: NRG 16-19 or NRG 16-27 installed on top of the body
- ▶ To detect loss of water seal: NRG16-19 or NRG16-27 installed at the side of the body

The following tool is required for installation work:

- ▶ Combination spanner to DIN 3113 form B:
  - ▶  $\frac{3}{8}$  " BSP connection: A. F. 17
  - ▶ NRG 16-19: A. F. 22
  - ▶ NRG 16-27 (new): A. F. 27
  - ▶ NRG 16-27 (old): A. F. 32
- ▶ Torque spanner (US: wrench) 60-120 Nm to DIN ISO 6789

### **Attention!**

The measuring electrode might get damaged if it is mounted incorrectly.

- ▶ Do not insulate the equipment after installation of the measuring electrode.
- ▶ Observe and follow all instructions given in the installation & operating manual for the measuring electrode.

To mount the measuring electrodes proceed as follows:

- ▶ Apply heat resistant lubricant to the threads and the terminal box side of the measuring electrode.

The lubricant must have the same properties as OKS®217.

- ▶ Use a suitable combination spanner to screw the measuring electrode into the desired connection on the body.
- ▶ Tighten the measuring electrode with a torque of 75 Nm.
- ▶ Connect the body to the pipework as described in the previous section.
- ▶ Attach an air balance pipe to the  $\frac{3}{8}$  " BSP connection.

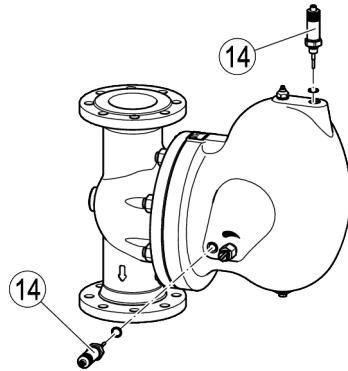

## Operation



### **WARNING**

Hot liquids and steam can cause scalding.

- ▶ Wear protective clothing that is suitable for the fluid and, if necessary, wear protective gear.

Protective clothing and protective gear must protect the whole body against contact with escaping hot steam.

For more information on suitable protective clothing and safety gear refer to the safety data sheet of the fluid in question.

During operation you can undertake the following work:

- ▶ Open and close the optional hand-vent valve
- ▶ Open and close the optional manual float-lifting lever

The optional hand vent valve allows manual air venting.

- ▶ To air vent the equipment turn the hand-vent valve (viewed from top) anticlockwise.
- ▶ To close the hand-vent valve after air-venting turn it clockwise.
- ▶ Fasten the hand-vent valve hand tight.

To operate the manual float-lifting lever a lever extension is supplied with the equipment.

The optional float-lifting lever allows the float to be manually lifted irrespective of the liquid level. It can be used to purge any dirt away from the seat area and out of the equipment by opening the orifice and draining the liquid.

The cast arrow on the body indicates the correct direction of rotation.

- ▶ To open the orifice turn the lever extension from the tip of the arrow towards the end of the arrow.
- ▶ To close the orifice turn the lever extension from the end of the arrow towards the tip of the arrow.

To operate the hand vent valve use the socket spanner (stock code number 526110) supplied with the equipment.

If an optional level indicator is fitted you can read off the fluid level during operation.

For more information see the separate installation and operating manual for the level indicator.

## After operation



### DANGER

If fluid escapes personnel may suffer severe injuries, poisoning or even loss of life.

- ▶ After working on the equipment make sure that all connections and valves are tight.
- ▶ Make sure that the gaskets of the body are leakproof.



### DANGER

Personnel working on pipes are exposed to safety risks and may suffer severe injuries, poisoning or even loss of life.

- ▶ Make sure that no hot or hazardous fluid is in the equipment or the pipes.
- ▶ Make sure that the pipes upstream and downstream of the equipment are depressurised.
- ▶ Make sure that the installation is switched off and protected against unauthorised or unintended activation.
- ▶ Make sure that the equipment and the pipes have cooled down to room temperatures.
- ▶ Wear protective clothing that is suitable for the fluid and, if necessary, wear protective gear.

For more information on suitable protective clothing and safety gear refer to the safety data sheet of the fluid in question.



### DANGER

If the equipment is used in contaminated areas there is a risk of severe injuries or death caused by harmful substances in or on the equipment.

- ▶ Only qualified personnel are allowed to perform work on contaminated equipment.
- ▶ Always wear the protective clothing prescribed for contaminated areas when working on the equipment.
- ▶ Make sure that the equipment is completely decontaminated before carrying out any service work.
- ▶ Follow the pertinent instructions for handling the hazardous substances in question.

## Attention!

Frost damage may occur when the installation is shut down.

- Drain the equipment if ambient temperatures below 0 °C (frost) are to be expected.

- Provide a device that collects any fluid that may escape.
- Remove the sealing plug (7) at the bottom of the body.
- Allow all liquid to escape and wait until the body is completely empty.
- To seal the drain hole screw in the sealing plug and tighten it with a torque of 75 Nm.

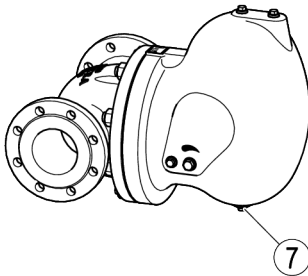

## Removing external dirt deposits

- To remove dirt deposits rinse the equipment with fresh water and wipe it with a clean, lint-free cloth.
- To remove any persistent residues use a cleaning agent that is suitable for the material and carefully wipe the equipment with a clean, lint-free cloth.

## Maintaining the equipment

For work on the equipment you will need the following tools:

- Combination spanner to DIN 3113 form B in various sizes:
- Several torque spanners to DIN ISO 6789, covering a torque range of 10-300 Nm
- Hexagon offset screwdriver ("Allen key") to DIN ISO 2936
- Screwdriver 5.5/125 to DIN 5265

Normally you do not have to clean the internal parts of the equipment.

To clean the equipment completely take off the cover and remove the control unit.

## Removing cover



Remove the measuring electrode(s) if mounted, before lifting off the cover.

- Use a suitable combination spanner to DIN 3113, form B, to remove the measuring electrode.
- Unscrew the eight hexagon nuts (1) off the stud bolts (5) on the body.
- Take the cover (6) off the body.
- Remove the body gasket (3).
- For the disposal of the body gasket observe the pertinent on-site regulations concerning waste disposal.

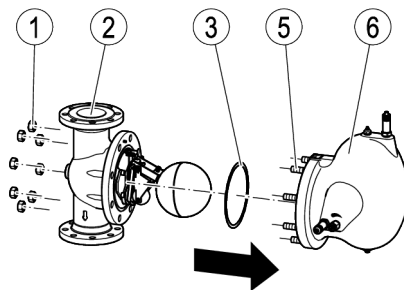



## Removing control unit

- Remove the cover from the body as described in the section "*Removing cover*" from page 16.
- Remove the two socket-head cap screws (20).
- Remove the control unit (4) together with the adapter (18) from the body.
- Remove the adapter gasket (17).
- Detach the control unit from the adapter.
- Remove the gasket (19) for the control unit.
- For the disposal of the gaskets observe the pertinent on-site regulations concerning waste disposal.

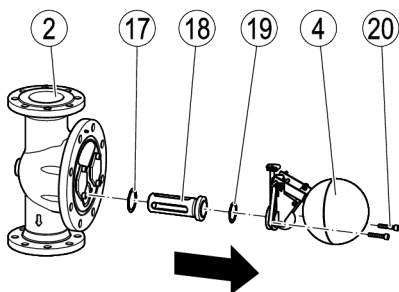

## Cleaning the equipment

Check the equipment at regular intervals for contamination. The intervals depend on the amount of dirt in the system. The operator must determine the maintenance intervals.

**i** Malfunctions may occur if the equipment is used with different types of condensate: The following condensates in particular cause problems:

- very oily condensates
- condensates that resinify or become gummy
- condensates that recrystallize
- condensates that contain solid matter.

In these cases check the equipment at regular intervals for contamination and, if necessary, remove dirt deposits.

To reduce contamination we recommend installing a sedimentation vessel or a dirt pocket arrangement upstream of the equipment.

To clean the inside of the equipment proceed as follows:

- Remove the cover from the body as described in the section "*Removing cover*" from page 16.
- Take out the control unit, as described on page 17.
- To remove dirt deposits rinse the equipment with fresh water and wipe it with a clean, lint-free cloth.
- To remove any persistent residues use a cleaning agent that is suitable for the material and carefully wipe the equipment with a clean, lint-free cloth.
- Remove any parts that are dirty and cannot be cleaned properly.
- Fit the control unit to the equipment, as described on page 18.
- Attach the cover to the body as described in the section "*Mounting cover*" from page 19.

## Cleaning and checking the membrane regulator capsule

To clean the membrane regulator capsule of equipment with a DUPLEX control unit proceed as follows:

- Remove the cover from the body as described in the section "Removing cover" from page 16.
- Remove the control unit as described in the section "Removing control unit" on page 17.
- Remove the membrane regulator capsule as described in section "Exchanging the membrane regulator capsule" on page 22.
- Clean the membrane regulator capsule with cold clean water.
- Use a depth gauge to check the dimension x of the membrane regulator capsule as shown in the following drawing.

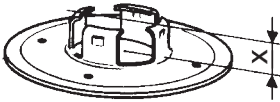

The membrane regulator capsule is intact if dimension x exceeds 4.0 mm.

- Discard and replace defective membrane regulator capsule with a new one.
- Mount the membrane regulator capsule as described in section "Exchanging the membrane regulator capsule" on page 22.

## Mounting the control unit

### Attention!

Malfunctions may occur if the control unit is installed incorrectly.

- When installing the equipment make sure that the name plate points upwards and the float arm is free to move up and down.
- Make sure that the flow arrow on the equipment body matches the direction of flow in the pipe.

- Replace all worn or damaged parts.
- Clean all dirty parts.
- Apply high-resistant lubricant to all threads, bearing faces of screws, nuts and bolts.

The lubricant must have the same properties as OKS® 217.

### Attention!

Equipment may leak if the gasket is damaged.

- Replace all gaskets that you loosen during your work.
  - Use only new gaskets of the same type.
- 
- Replace all gaskets with new ones of the same type.
  - Insert a new gasket (19) for the control unit into the adapter (18).
  - Attach the control unit (4) to the adapter.
  - Insert a new adapter gasket (17) in the adapter (18).
  - Attach the control unit (4) together with the adapter to the body (2) using the two socket-head cap screws (20).
  - Tighten the socket-head cap screws with a torque of 30 Nm.

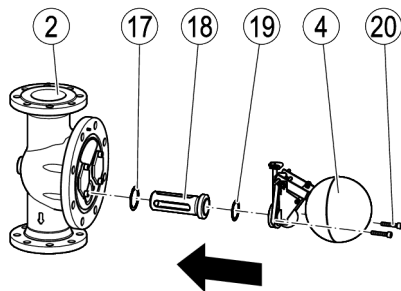

- Attach the cover to the body as described in the section "Mounting cover" from page 19.

- 
- Check all removed parts for signs of damage.

## Mounting cover

### **Attention!**

Equipment may leak if the gasket is damaged.

- It is therefore essential that you always insert a new gasket before re-attaching the cover.
- Make sure that the cover is not tilted or skewed when refitted.

- Clean the gasket surfaces of the cover and body.
- Apply heat resistant lubricant to the threads and bearing faces of the screws.

The lubricant must have the same properties as OKS® 217.

- Put a new body gasket (3) onto the body (2).
- Insert the eight stud bolts (5) into the bores of the body.
- Refit the cover (6) onto the body such that the name plate (8) points upwards.

The torque required for tightening the eight hexagon nuts (1) depends on the type.

- ◆ Tighten the hexagon nuts for UNA 43 with a torque of 80 Nm.
- ◆ Tighten the hexagon nuts for UNA 46 with a torque of 230 Nm.
- Fasten the hexagon nuts with the specified torque.

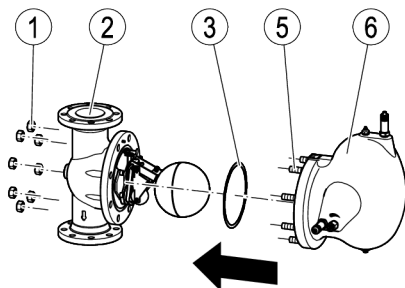

- If necessary, fit the measurement electrode as described in the section "*Mounting the measuring electrode*" on page 14.

# Servicing the equipment and installing spare parts

You may exchange the following component parts in case of wear or damage:

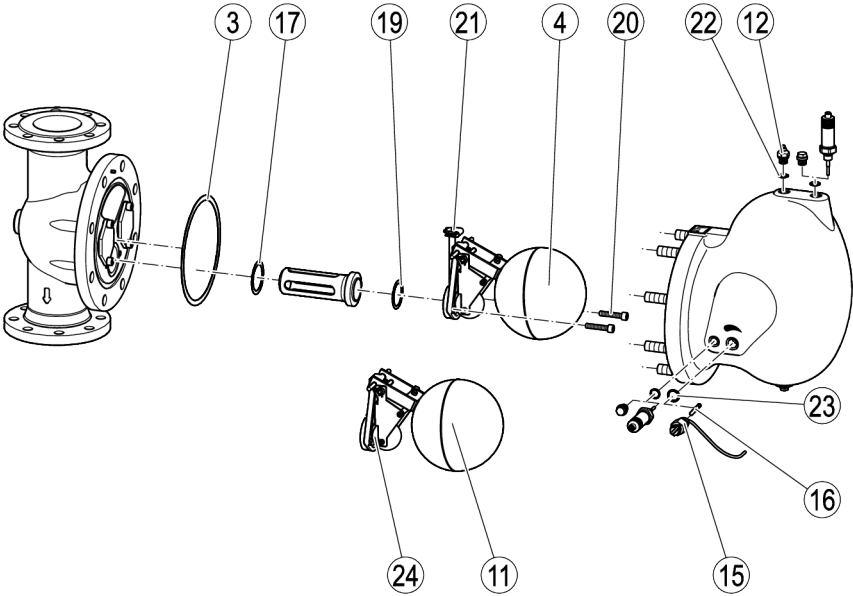

Item no.	Designation	Orifice	Stock code #	
			DUPLEX	SIMPLEX
3, 4/11, 17, 19, 20	Control unit including orifice, cpl. with body gasket, adapter gasket and gasket for control unit, socket-head cap screws	2	560720	560727
		4	560721	560728
		8	560722	560729
		13	560723	560730
		22	560724	560731
		32	560725	560732
		40	560726	560733
3, 17, 19, 22, 23,	Gasket set <sup>1</sup>	all	560750	
12, 22	Hand-vent valve, cpl. with joint ring and socket spanner	all	560676	
15, 16, 23	Manual float lifting lever, cpl. with gasket and lever extension	all	560749	
3, 21	Membrane regulator capsule 5N2, cpl. with body gasket	all	560748	
24	Orifice	2	560734	560741
		4	560735	560742
		8	560736	560743
		13	560737	560744
		22	560738	560745
		32	560739	560746
		40	560740	560747
—	Socket spanner for hand vent valve	all	560700	

1 Comprises:

- ▶ 4 gaskets 3/8" BSP
- ▶ 1 gasket 3/8" 'BSP
- ▶ 1 body gasket
- ▶ 1 gasket for control unit
- ▶ 1 adapter gasket

### Exchanging the control unit

- Take out the control unit, as described on page 17.
- Fit the control unit to the equipment, as described on page 18.

### Exchanging the membrane regulator capsule

- Remove the cover from the body as described in the section "*Removing cover*" from page 16.
- Push the mounting clip (25) off the control unit (1.).
- Pull the membrane regulator capsule (21) upwards and off the seat (26) (2.).

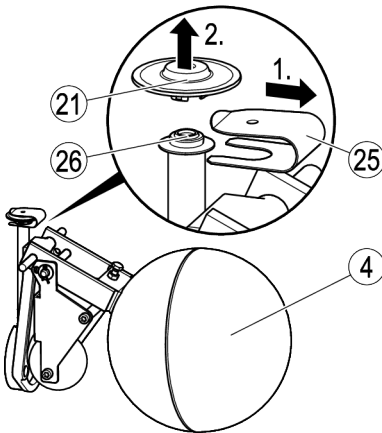

Install the new membrane regulator capsule as follows:

- Press the membrane regulator capsule onto the seat until it snaps into place.
- Slip the mounting clip over the membrane regulator capsule.
- Attach the cover to the body as described in the section "*Mounting cover*" from page 19.

### Exchanging the hand-vent valve

- Unscrew the hand vent valve or the sealing plug off the bore.



### Danger

Fluid may escape if connections are leaking or sealing rings are damaged.

- Insert a new gasket before re-installation.
  - Use the sealing plug to close the vent hole if you do not mount the hand vent valve.
- 
- Insert a new gasket into the bore.
  - Screw the hand vent valve or the sealing plug hand tight into the bore.
  - Tighten the hand vent valve or the sealing plug to a torque of 75 Nm.

## Exchanging the float-lifting lever

- If necessary remove the lever extension (16).
- Loosen the manual float-lifting lever (15) and the stuffing-box packing (27).
- Remove the float-lifting lever from the body.
- Remove the gasket (23).

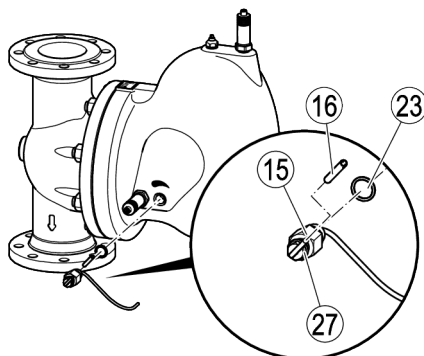

### Danger

Fluid may escape if connections are leaking or gaskets are damaged.

- When fitting the new manual float-lifting lever use only the stuffing-box packing supplied with the equipment.
- 
- Replace the gasket with a new one.
  - Mount the manual float-lifting lever in reverse order.

The torque required for tightening the float-lifting lever depends on the type.

- ▶ For UNA 43 a torque of 75 Nm is required.
  - ▶ For UNA 46 a torque of 140 Nm is required.
- Use a torque spanner A.F. 36 to tighten the float-lifting lever to the specified torque.
  - Pull the lever out of the stuffing-box packing.
  - Attach the lever extension.
  - Turn the float-lifting lever.

---

### Attention!

Equipment may not work properly or get damaged if the stuffing-box packing is tightened with the wrong torque.

- Tighten the stuffing-box packing hand tight.
  - Make sure that the requirements are met:
- 
- ▶ The stuffing box packing must not leak.
  - ▶ The float-lifting lever must be able to move freely.
  - Check the float-lifting lever for proper functioning and the stuffing-box packing for leaks.
  - If it is not possible to meet these requirements you have to replace the float-lifting lever with the stuffing-box packing.

## Troubleshooting

<b>Problem</b>	<b>Cause</b>	<b>Remedy</b>
The discharge capacity is too low. Insufficient thermal output of the user.	The equipment is undersized.	Use equipment with a larger discharge capacity.
The discharge capacity is too low. Insufficient thermal output of the user.	Steam pressure and condensate flowrate fluctuate considerably. The pressure upstream of the equipment is too low for the used equipment type.	Use equipment with a larger discharge capacity. If necessary, use a pump steam trap or a condensate return unit.
Fluid escapes (equipment is leaking).	The body has been damaged by corrosion or erosion.	Replace the equipment with a new one. Use equipment made of material that is suitable for the application.
Fluid escapes (equipment is leaking).	The equipment has been damaged by waterhammer.	Replace the equipment with a new one. Take appropriate measures to protect the equipment against waterhammer. Use e. g. non-return valves or a pump steam trap.
The discharge capacity is too low. Insufficient thermal output of the user.	The differential pressure is too small.	Increase the steam pressure. Lower the pressure in the condensate line. Use equipment with a larger discharge capacity. If necessary, use a pump steam trap or a condensate return unit.
The discharge capacity is too low. Insufficient thermal output of the user.	Insufficient deaeration.	Connect an additional air vent.
The discharge capacity is too low. Insufficient thermal output of the user.	The pipes do not have a continuous fall in flow direction.	Make sure that the lines run with a continuous fall in flow direction.
Fluid escapes (equipment is leaking).	The equipment has been damaged by frost.	Replace the equipment with a new one. When shutting down the installation make sure that all lines and the equipment are completely drained.



<b>Problem</b>	<b>Cause</b>	<b>Remedy</b>
The discharge capacity is too low. The equipment is cold or only warm to the touch.	The shut-off valves for fluid flow are closed.	Fully open the shut-off valves.
The equipment is cold or only warm to the touch.	The sealing plugs are still attached to the connections.	Remove the equipment. Remove the sealing plugs. Mount the equipment.
Fluid escapes (equipment is leaking).	The equipment or the body is damaged.	Replace the equipment with a new one.
Fluid escapes (equipment is leaking).	A gasket is damaged.	Replace the gasket with a new one. Clean gasket seating surfaces.
Fluid escapes (equipment is leaking).	The connections are not tight.	Provide the connections with leakproof seals.
Fluid escapes (equipment is leaking).	The stuffing box packing has not been tightened enough.	Tighten the stuffing-box packing hand tight. Make sure that the stuffing box packing does not impair the movement of the internals.
Fluid escapes (equipment is leaking).	The stuffing-box packing is damaged.	Replace the stuffing-box packing.
The discharge capacity is too low. The equipment is cold or only warm to the touch. Insufficient thermal output of the user.	The inlet, outlet or the equipment is dirty.	If fitted, operate the float-lifting lever. Clean the pipes. Clean all internals. If necessary, replace internals or the whole equipment.
The equipment is blowing off live steam.	The control unit is damaged or worn.	Replace the control unit.
The equipment is blowing off live steam.	Dirt deposits, precipitated solids or foreign particles have accumulated in the equipment.	If fitted, operate the float-lifting lever. Clean the pipes. Clean all internals. If necessary, replace internals or the whole equipment.

- If faults occur that are not listed above or cannot be corrected, please contact our Technical Service or authorized agency in your country.

## Putting the equipment out of operation

### Removing harmful substances



#### DANGER

If the equipment is used in contaminated areas there is a risk of severe injuries or death caused by harmful substances in or on the equipment.

- Only qualified personnel are allowed to perform work on contaminated equipment.
- Always wear the protective clothing prescribed for contaminated areas when working on the equipment.
- Make sure that the equipment is completely decontaminated before carrying out any service work.
- Follow the pertinent instructions for handling the hazardous substances in question.

Qualified personnel must have extensive experience with and a working knowledge of:

- ▶ pertinent rules and regulations concerning handling hazardous substances
- ▶ special regulations for handling the hazardous substances encountered on site
- ▶ using the required personal protective equipment (PPE) and clothing



#### CAUTION

Environmental damage may be caused by poisonous fluid residues.

- Before disposing of the equipment make sure that it is clean and free of fluid residues.
  - For the disposal of all materials observe the pertinent legal regulations concerning waste disposal.
- 
- Remove all residues from the equipment.
  - For the disposal of all residues observe the pertinent legal regulations concerning waste disposal.

### Removing the equipment



#### DANGER

Personnel working on pipes are exposed to safety risks and may suffer severe injuries, poisoning or even loss of life.

- Make sure that no hot or hazardous fluid is in the equipment or the pipes.
- Make sure that the pipes upstream and downstream of the equipment are depressurised.
- Make sure that the installation is switched off and protected against unauthorised or unintended activation.
- Make sure that the equipment and the pipes have cooled down to room temperatures.
- Wear protective clothing that is suitable for the fluid and, if necessary, wear protective gear.

For more information on suitable protective clothing and safety gear refer to the safety data sheet of the fluid in question.

- Make sure that all pipelines upstream and downstream of the equipment are depressurised.



## CAUTION

Do not drop the equipment. If it falls down it may cause bruises and injuries.

- When dismantling the equipment use suitable lifting gear.
- Connect the noose strap of the lifting gear to the body.
- Provide sufficient support for the equipment.
- Wear protective safety footwear.

- 
- Detach the end connections of the equipment from the pipes.
  - Put the equipment onto a suitable base.
  - Store the equipment as described on page 10.

## Re-using equipment after storage

Observe the following instructions if you want to remove the equipment and use it again somewhere else:

- ◆ Make sure that the equipment is free of any fluid residues.
- ◆ Make sure that all connections are in good condition and leak-free.
- Use the equipment only for its intended purpose and the service conditions for which it was specified.

## Disposing of the equipment



### CAUTION

Environmental damage may be caused by poisonous fluid residues.

- Before disposing of the equipment make sure that it is clean and free of fluid residues.
- For the disposal of all materials observe the pertinent legal regulations concerning waste disposal.

The equipment is made from the following materials:

Component part	Type	EN	ASTM
Body	UNA 43	5.1301	A126-B
	UNA 46	1.0619	SA216-WCB
Cover	UNA 43	5.1301	A126-B
	UNA 46	1.0619	SA216-WCB
Body gasket, control unit gasket, adapter gasket	all	Graphite-CrNi	
Membrane regulator capsule	all	Hastelloy / stainless steel	
Sealing plugs, stud bolts, nuts, manual float-lifting lever	all	Forged steel, heat resistant	
Other components	all	Stainless steel	

## Technical data

### Dimensions and weights

The drawing shows equipment with flanged connection for downward flow.

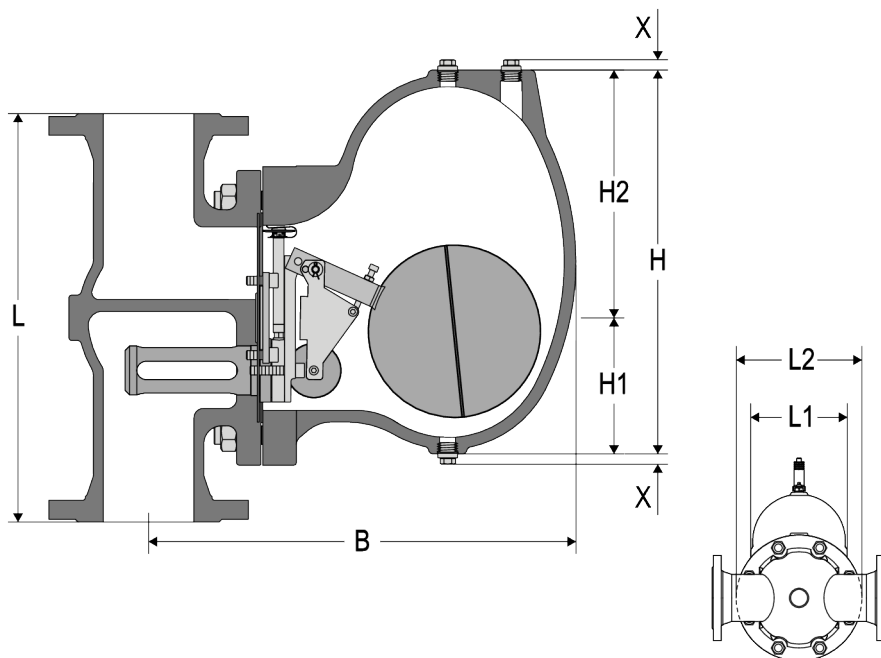

**DN 80 (3")**

<b>Abbreviation</b>	<b>End connection</b>	<b>[mm]</b>	<b>["]</b>
B	all	471	18.5
H1	all	150	5.9
H2	all	273	10.7
H	all	423	16.7
L1	all	250	9.8
L2	all	325	12.8
L	Flange to EN	450	17.7
	Flange to ASME, JIS	457	18.0
X	all	13	0.5
<b>Weights</b>		<b>[kg]</b>	<b>[lb]</b>
Weight	EN PN16/40, ASME CL 125/150, JIS 10K, JIS 20K	111	244.7
	UNA 46 ASME CL 300	114	251.3

**DN 100 (4")**

<b>Abbreviation</b>	<b>End connection</b>	<b>[mm]</b>	<b>["]</b>
B	all	471	18.5
H1	all	150	5.9
H2	all	273	10.7
H	all	423	16.7
L1	all	250	9.8
L2	all	325	12.8
L	Flange to EN	450	17.7
	Flange to ASME, JIS	457	18.0
X	all	13	0.5
<b>Weights</b>		<b>[kg]</b>	<b>[lb]</b>
Weight	EN PN16/40, ASME CL 125/150, JIS 10K, JIS 20K	117	257.9
	UNA 46 ASME CL 300	125	275.6

**DN 150 (6")**

<b>Abbreviation</b>	<b>End connection</b>	<b>[mm]</b>	<b>["]</b>
B	all	503	19.8
H1	all	150	5.9
H2	all	273	10.7
H	all	423	16.7
L1	all	250	9.8
L2	all	325	12.8
L	Flange to EN	500	19.7
	Flange to ASME, JIS	502	19.75
X	all	13	0.5
<b>Weights</b>		<b>[kg]</b>	<b>[lb]</b>
Weight	UNA 43 EN PN 16, ASME CL 125, JIS 10K	132	291.0
	UNA 46 EN PN 40, ASME CL 150, JIS 10K, JIS 20K	138	304.2
	UNA 46 ASME CL 300	150	330.7

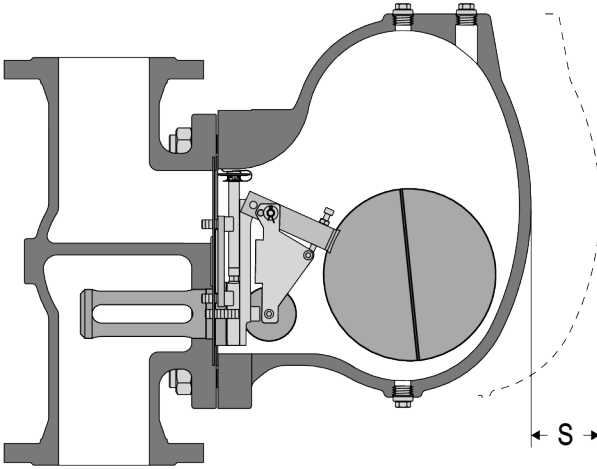

To remove the cover a withdrawal space S of 350 mm is required.

If the supplied socket spanner or the lever extension is attached to the equipment an additional clearance of 150 mm is required.



## Pressure & temperature ratings

You can find the values for your equipment on the rating plate.

The max. differential pressure  $\Delta$  PMX of the equipment depends on the type of orifice (O) used.

<b>Orifice</b>	<b><math>\Delta</math>PMX [bar]</b>	<b>Diameter of bore [mm]</b>
2	2	32.0
4	4	25.8
8	8	19.8
13	13	16.6
22	22	18.5
32	32	15.9
40	40	14.5

## **Declaration of Conformity – Standards and Directives**

You can find details on the conformity of the equipment and the applicable standards and directives in the Declaration of Conformity and the relevant certificates.

You can download the latest Declaration of Conformity at [www.gestra.com](http://www.gestra.com). You can request the relevant certificates by writing to the following address:

### **GESTRA AG**

Münchener Straße 77

28215 Bremen

Germany

Phone +49 421 3503-0

Fax +49 421 3503-393

e-mail [info@de.gestra.com](mailto:info@de.gestra.com)

Web [www.gestra.com](http://www.gestra.com)

Modifications to the equipment not approved by us will invalidate the Declaration of Conformity and the certificates.





You can find our authorized agents around the world at: [www.gestra.com](http://www.gestra.com)

**GESTRA AG**

Münchener Strasse 77  
28215 Bremen  
Germany

Phone +49 421 3503-0  
Fax +49 421 3503-393  
e-mail [info@de.gestra.com](mailto:info@de.gestra.com)  
Web [www.gestra.com](http://www.gestra.com)

**UK Importer**

GESTRA UK Ltd

Unit 1 Sopwith Park, Royce Close,  
West Portway Business Park, Andover,  
Hampshire SP10 3TS  
United Kingdom

819565-01/05-2022 kx\_mm [uk] (808959-01) © GESTRA AG Bremen Printed in Germany