

# w.t.a.<sup>®</sup>

brands you trust.



Change Over Valves

Types 11.7, 11.8, 11.75 and 11.85

**CRANE**<sup>®</sup>

Crane ChemPharma & Energy

[www.cranecpe.com](http://www.cranecpe.com)



### Company History and Introduction

WTA®, a brand of Crane ChemPharma & Energy, was founded in 1978. WTA® designs and manufactures a comprehensive range of high-quality bellows sealed globe valves, chlorine valves, changeover valves, relief valves, and special valves to meet the stringent specifications required by the global chemical, refining and petrochemical industries.

Backed by a history of engineering excellence and manufactured from the highest-quality materials, bellows sealed globe valves from WTA® lead the industry in innovation and safety. With superior design and construction, WTA® valves incorporate the market's most advanced safety features to ensure low fugitive emissions, leak-proof performance, and long service life.

### Manufacturing Location

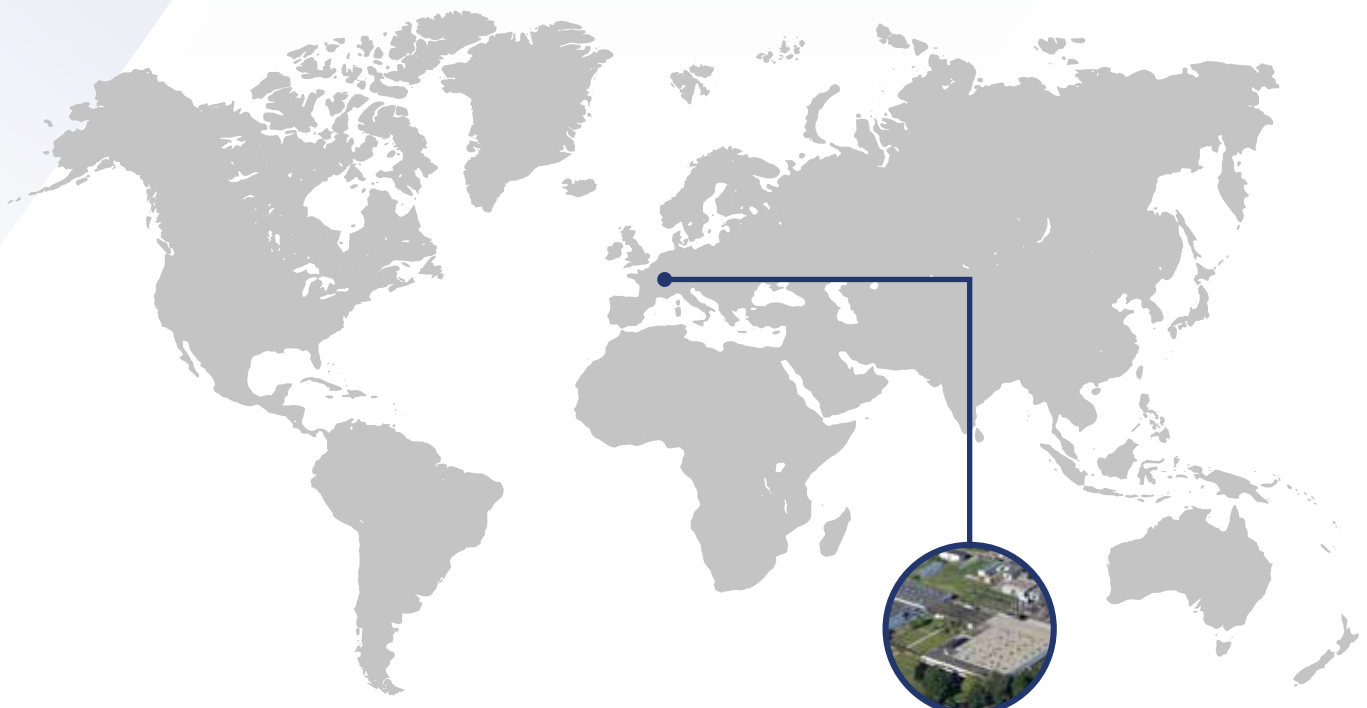

LINDAU, GERMANY

# Introduction Change Over Valves

## What are Change Over Valves?

Change over valves are used to connect two safety valves to a pressure system using one pipe point. Here, one safety valve is in operation and one safety valve is on stand-by. The stand-by valve can be removed during ongoing operation for service, while protection of the pressure system against inadmissible pressures is maintained.

The use of change over valves allows essential maintenance work to be carried out on a safety valve, without interruption of the plant operation. This is realized by simply switching over to the relevant stand by safety valve, thus protecting the plant against excessive overpressure.

## Applications

Change over valves are used in various industries in order to ensure continuous operation and to minimize safety risks due to unplanned shutdown periods.

These industries are:

- Petrochemical industry
- Oil and gas industry
- Technical gases
- Chemical
- Refrigeration
- Pharmaceutical industry

## Key Features

**Our three-way change over valves provide extremely low pressure drop due to optimal flow deflection and are of compact, weight-saving design**

### Key features include:

- The three-way change over valves are ideal for environments where continuous plant operation is essential.
- Extremely low pressure loss coefficients (zeta values from 0,60 to 1,05) permit optimal flow rates to fulfill the legal requirement of less than 3% pressure loss.
- Two designs are available for use in chemical, petrochemical, pharmaceutical or refining services: one with packing sealing (11.7/11.75) and one with bellows sealing (11.8/11.85).

## Technical Details

### Materials of Construction

- Carbon steel 1.0619 / WCB / WCC
- Stainless steel 1.4408 / CF8M
- Low temperature carbon steel 1.6220 / LCB / LCC
- Special materials on request

### Size Range

- DN15-400 / NPS 1/2"-16"
- *\*Other sizes are available upon request*
- End Connections available according to DIN and ASME standards
- Flange design in accordance with EN 1092-1 and ASME B 16.5.

### Compliance

- Permissible working pressure according EN 1092 part 1 and ASME B16.34-2009
- Inspection and testing per EN 12266 and API 598
- Design in accordance with TA-Luft (11.8/11.85)
- TR certificate of conformity

### Pressure Ratings

- PN10-400 / Class 150-2500

### Temperature Range

Standard	Unit	Temp.	Carbon Steel	Stainless Steel	Low Temp. Carbon Steel
DIN	°C	Tmin	-10	-200	-40
		Tmax	+400	+400	+300
	°F	Tmin	+14	-328	-40
		Tmax	+752	+752	+572
ASME	°C	Tmin	-29	-268	-46
		Tmax	+425	+400	+345
	°F	Tmin	-20	-450	-50
		Tmax	+797	+752	+653

## Change Over Valve 11.8/11.85

**1.** Two piece rising stem with outside roll-formed thread; stem coupling with bellows **anti-torque device** and position indicator



**2.** Multiple wall, fully flushed stainless steel bellows, secured against torsion, designed for 10,000 operations; fully welded (11.8/11.85), metal back seat with stroke limiter

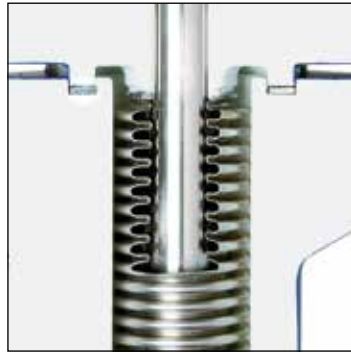

**3.** Plug screw sealing off guide bushing and guide stem towards the atmosphere

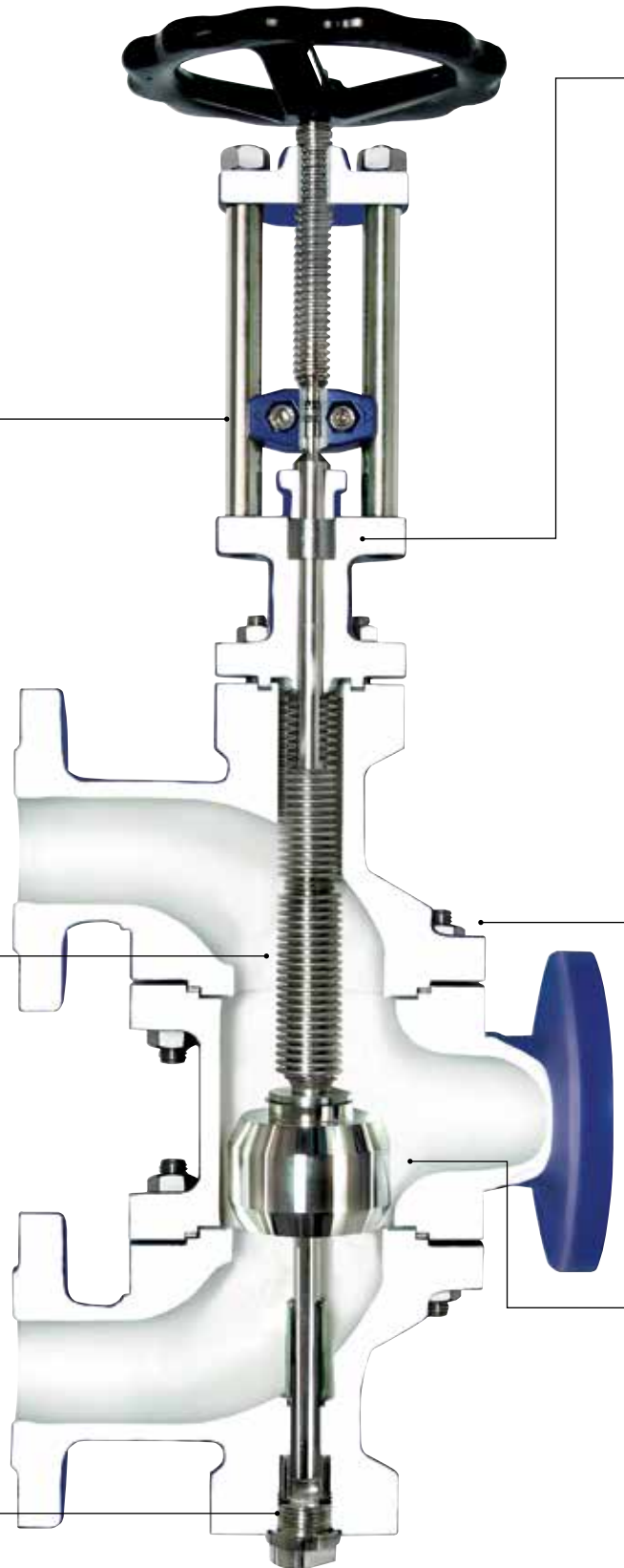
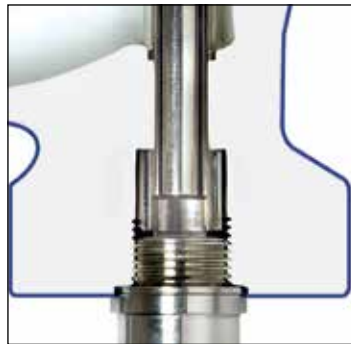

## Change Over Valve 11.8/11.85

### Product Description

**Type 11.8:** Three-way change over valve with safety gland packing and bellows in flange design

**Type 11.7:** Three-way change over valve with gland packing in flange design

### Special Options

- **Type 11.75/11.85:** change over valves—combination with safety relief valves



**4.** Full size **safety gland packing** made of pure graphite; can also be supplied in PTFE if requested



**5.** Stainless steel camprofiled bonnet gasket coated by pure graphite, mounted in **tongue and grooved** bonnet flanges, PTFE also available for gasket



**6.** Conical shaped plug made of **hardened chromium steel** 1.4021 or hard faced with stellite 6; **body seat hardfaced with stainless steel** 1.4370 or stellite 21

# Change Over Valve, Gland Type 11.7-FL

DN15-400 / 1/2"-16"			
PN 40 / ASME 150 - 300			
	C.S.	S.S.	Low temp.
Tmin.	-10°C	-200°C	-40°C
Tmax.	+400°C	+400°C	+300°C

Permissible working pressure acc. EN 1092 - Part 1
Terms of delivery acc. DIN 3230/EN 12266-1
Detailed information and more alternatives are given in the appendix

Components	Material		
	C.S.	S.S.	Low temp.
	11.7-FL	11.7-FL-A4	11.7-FL-TT
Body	1.0619	1.4408	1.6220
Body seat	1.4370	Stellite 21	1.4370
Bonnet	1.0619	1.4408	1.6220
Disc	1.4021 1.0460/1.0619	1.4571/1.4408	1.4571/1.0566 1.6220
Disc surface	Vacuum hardened (1.0421) Stellite 21 (1.0460/1.0619)	Stellite 6	Stellite 6 Stellite 21
Gaskets	1.4571/graphite		
Bolts	A2/70	A2/70	A2/70
Nuts	A2/70	A2/70	A2/70
Gland packing	Pure graphite		
Gland	1.0420	1.4408	1.4408
Stem-upper part	1.4122	1.4122	1.4122
Stem-lower part	1.4301	1.4571	1.4571
Handwheel	0.6020	0.6020	0.6020

DN	L [mm]	H [mm]	H1 [mm]	D1 [mm]	G [kg]
15	115	190	395	175	25
20	115	190	395	175	25
25	115	190	395	175	25
32	150	265	545	200	46
40	150	265	545	200	46
50	150	265	535	200	49
65	190	360	740	300	96
80	190	360	740	300	99
100	230	460	815	300	151
125	300	460	815	300	156
150	280	600	1110	400	323
200	370	800	1445	500	667
250	430	900	1670	600	830
300	440	950	1670	600	950
350	470	1090	2170	800	1480
400	480	1140	2170	800	1790

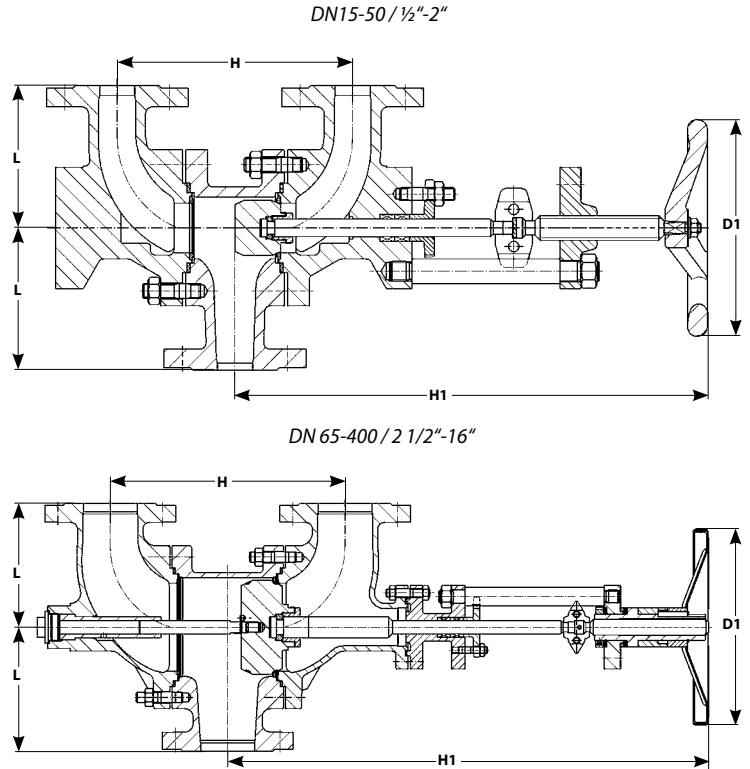

WTA® Change Over Valve with flanges acc. EN 1092-1 or ASME B 16.5; with outside roll-formed stem screw thread and burnished shaft. With safety stuffing box packing made of pure graphite and grooved bonnet gasket made of stainless steel 1.4571 with a coating of pure graphite on both sides, housed in a tongue and grooved flange.

Coefficients of resistant ( z )		
DN	stem side	opposite side
25	0,6	0,6
40	0,6	0,7
50	0,7	0,9
65	0,83	0,90
80	0,83	0,90
100	0,79	0,94
125	0,84	0,98
150	0,81	0,89
200	0,84	0,92
250	0,99	0,96
300	0,84	0,91
350	0,89	0,85
400	0,83	0,79

# Change Over Valve, Bellows Sealed Type 11.8-FL

DN15-400 / 1/2"-16"			
PN 40 / ASME 150 - 300			
	C.S.	S.S.	Low temp.
Tmin.	-10°C	-200°C	-40°C
Tmax.	+400°C	+400°C	+300°C

Permissible working pressure acc. EN 1092 - Part 1  
 Terms of delivery acc. DIN 3230/EN 12266-1  
 Detailed information and more alternatives are given in the appendix

Component	Material		
	C.S.	S.S.	Low temp.
	<b>11.8-FL</b>	<b>11.8-FL-A4</b>	<b>11.8-FL-TT</b>
Body	1.0619	1.4408	1.6220
Body seat	1.4370	Stellite 21	1.4370
Bonnet	1.0619	1.4408	1.6220
Disc	1.4021 1.0460/1.0619	1.4571/1.4408	1.4571/1.0566 1.6220
Disc surface	Vacuum hardened (1.0421) Stellite 21 (1.0460/1.0619)	Stellite 6	Stellite 6 Stellite 21
Bellows	1.4571	1.4571	1.4571
Gaskets	1.4571/graphite		
Bolts	A2/70	A2/70	A2/70
Nuts	A2/70	A2/70	A2/70
Gland packing	Pure graphite		
Gland	1.0420	1.4408	1.4408
Stem-upper part	1.4122	1.4122	1.4122
Stem-lower part	1.4301	1.4571	1.4571
Handwheel	0.6020	0.6020	0.6020

DN	L [mm]	H [mm]	H1 [mm]	D1 [mm]	G [kg]
15	115	190	480	175	27
20	115	190	480	175	27
25	115	190	480	175	27
32	150	265	625	200	47
40	150	265	625	200	47
50	150	265	615	200	50
65	190	360	910	300	106
80	190	360	910	300	109
100	230	460	985	300	161
125	300	460	985	300	166
150	280	600	1390	400	338
200	370	800	1720	500	682
250	430	900	1670	600	850
300	440	950	1670	600	970
350	470	1090	2465	800	1500
400	480	1140	2465	800	1810

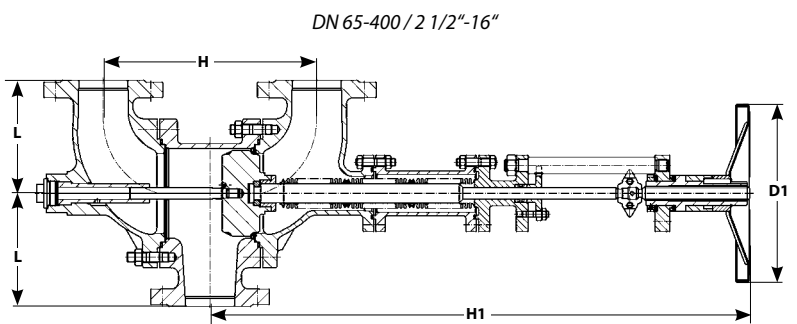
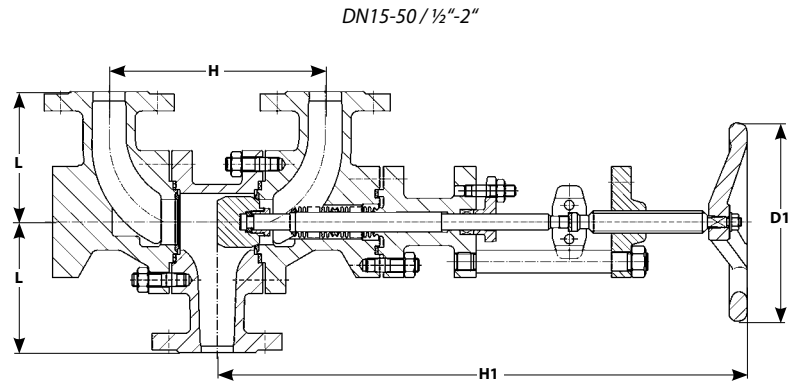

WTA® Bellows Sealed Change Over Valve with flanges acc. EN 1092-1 or ASME B 16.5; with outside roll-formed stem screw thread and burnished shaft, coupled stem. Multiple-wall liquid contacted bellows made of stainless steel, with anti torque device, safety stuffing box packing made of pure graphite and grooved bonnet gasket made of stainless steel 1.4571 with a coating of pure graphite on both sides, housed in a tongue and grooved flange.

Coefficients of resistant ( z )		
DN	stem side	opposite side
25	1,0	0,6
40	0,8	0,7
50	0,8	0,9
65	0,93	0,90
80	0,93	0,90
100	0,89	0,94
125	0,94	0,98
150	0,91	0,89
200	0,94	0,92
250	1,05	0,96
300	0,91	0,89
350	0,94	0,85
400	0,91	0,79

# Interlocking Change Over Valve, Gland Type **11.75-FL**

DN15-400 / ½"-16"			
PN 40 / ASME 150 - 300			
	C.S.	S.S.	Low temp.
Tmin.	-10°C	-200°C	-40°C
Tmax.	+400°C	+400°C	+300°C

Permissible working pressure acc. EN 1092 - Part 1  
 Terms of delivery acc. DIN 3230/EN 12266-1  
 Detailed information and more alternatives are given in the appendix

Components	Material		
	C.S.	S.S.	Low temp.
	11.75-FL	11.75-FL-A4	11.75-FL-TT
Body	1.0619	1.4408	1.6220
Body seat	1.4370	Stellite 21	1.4370
Bonnet	1.0619	1.4408	1.6220
Disc	1.4021 1.0460/1.0619	1.4571/1.4408	1.4571/1.0566 1.6220
Disc surface	Vacuum hardened (1.0421) Stellite 21 (1.0460/1.0619)	Stellite 6	Stellite 6 Stellite 21
Gaskets	1.4571/graphite		
Bolts	A2/70	A2/70	A2/70
Nuts	A2/70	A2/70	A2/70
Gland packing	Pure graphite		
Gland	1.0420	1.4408	1.4408
Stem-upper part	1.4122	1.4122	1.4122
Stem-lower part	1.4301	1.4571	1.4571
Handwheel	Steel	Steel	Steel
Chainwheel	CG 20-25	CG 20-25	CG 20-25

DN	L [mm]	H [mm]	H1 [mm]	D1 [mm]	G [kg]
15	115	190	385	200	26
20	115	190	385	200	26
25	115	190	385	200	26
32	150	265	500	200	47
40	150	265	500	200	47
50	150	265	515	200	49
65	190	360	740	300	96
80	190	360	740	300	99
100	230	460	815	300	151
125	300	460	815	300	156
150	280	600	1110	400	323
200	370	800	1445	500	667
250	430	900	1670	600	830
300	440	950	1670	600	950
350	470	1090	2170	800	1480
400	480	1140	2170	800	1790

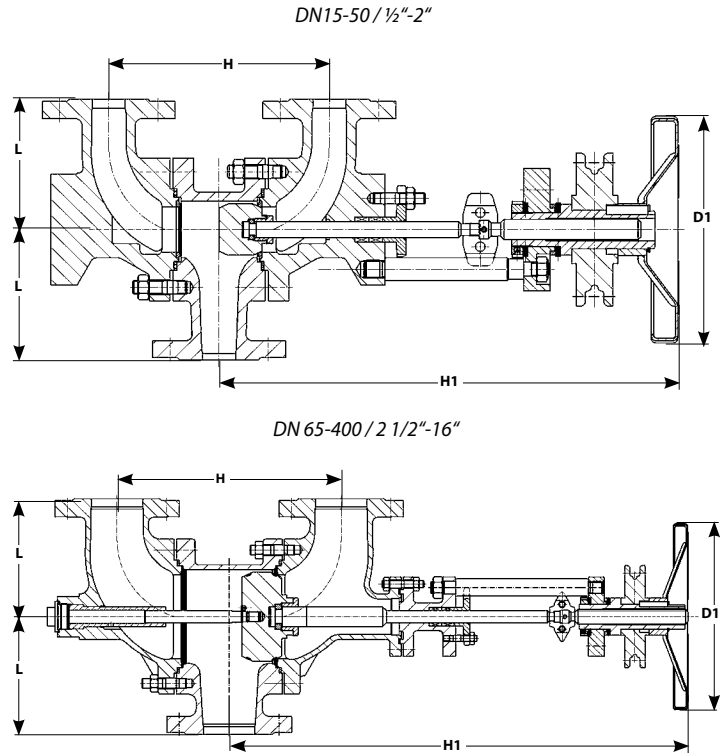

WTA® Change Over Valve with flanges acc. EN 1092-1 or ASME B 16.5; with outside roll-formed stem screw thread and burnished shaft. With safety stuffing box packing made of pure graphite and grooved bonnet gasket made of stainless steel 1.4571 with a coating of pure graphite on both sides, housed in a tongue and grooved flange.

Coefficients of resistant ( z )		
DN	stem side	opposite side
25	0,6	0,6
40	0,6	0,7
50	0,7	0,9
65	0,83	0,90
80	0,83	0,90
100	0,79	0,94
125	0,84	0,98
150	0,81	0,89
200	0,84	0,92
250	0,99	0,96
300	0,84	0,91
350	0,89	0,85
400	0,83	0,79



# Interlocking Change Over Valve, Bellows Sealed Type 11.85-FL

DN15-400 / ½"-16"			
PN 40 / ASME 150 - 300			
	C.S.	S.S.	Low temp.
Tmin.	-10°C	-200°C	-40°C
Tmax.	+400°C	+400°C	+300°C

Permissible working pressure acc. EN 1092 - Part 1

Terms of delivery acc. DIN 3230/EN 12266-1

Detailed information and more alternatives are given in the appendix

Component	Material		
	C.S.	S.S.	Low temp.
	11.85-FL	11.85-FL-A4	11.85-FL-TT
Body	1.0619	1.4408	1.6220
Body seat	1.4370	Stellite 21	1.4370
Bonnet	1.0619	1.4408	1.6220
Disc	1.4021	1.4571/1.4408	1.4571/1.0566
	1.0460/1.0619		1.6220
Disc surface	Vacuum hardened (1.0421)	Stellite 6	Stellite 6
	Stellite 21 (1.0460/1.0619)		Stellite 21
Bellows	1.4571	1.4571	1.4571
Gaskets	1.4571/graphite		
Bolts	A2/70	A2/70	A2/70
Nuts	A2/70	A2/70	A2/70
Gland packing	Pure graphite		
Gland	1.0420	1.4408	1.4408
Stem-upper part	1.4122	1.4122	1.4122
Stem-lower part	1.4301	1.4571	1.4571
Handwheel	Steel	Steel	Steel
Chainwheel	CG 20-25	CG 20-25	CG 20-25

DN	L [mm]	H [mm]	H1 [mm]	D1 [mm]	G [kg]
15	115	190	470	200	28
20	115	190	470	200	28
25	115	190	470	200	28
32	150	265	585	200	48
40	150	265	585	200	48
50	150	265	600	200	52
65	190	360	910	300	106
80	190	360	910	300	109
100	230	460	985	300	161
125	300	460	985	300	166
150	280	600	1390	400	338
200	370	800	1720	500	682
250	430	900	1670	600	850
300	440	950	1670	600	970
350	470	1090	2465	800	1500
400	480	1140	2465	800	1810

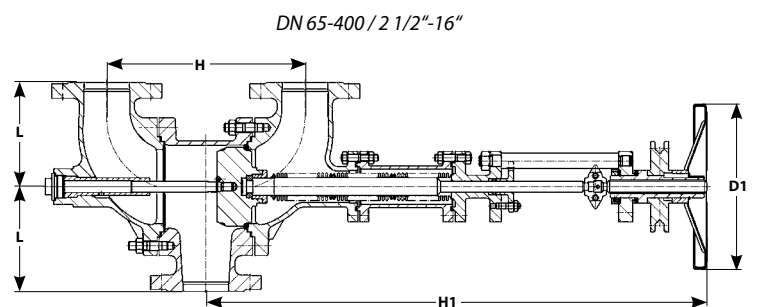
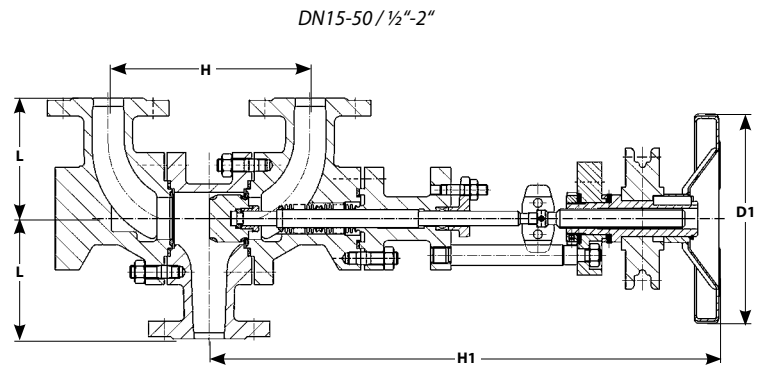

WTA® Bellows Sealed Change Over Valve with flanges acc. EN 1092-1 or ASME B 16.5; with outside roll-formed stem screw thread and burnished shaft, coupled stem. Multiple-wall liquid contacted bellows made of stainless steel, with anti torque device, safety stuffing box packing made of pure graphite and grooved bonnet gasket made of stainless steel 1.4571 with a coating of pure graphite on both sides, housed in a tongue and grooved flange.

Coefficients of resistant ( z )		
DN	stem side	opposite side
25	1,0	0,6
40	0,8	0,7
50	0,8	0,9
65	0,93	0,90
80	0,93	0,90
100	0,89	0,94
125	0,94	0,98
150	0,91	0,89
200	0,94	0,92
250	1,05	0,96
300	0,91	0,89
350	0,94	0,85
400	0,91	0,79

# Overview Potential Installations, Change Over Valves

## Change Over Valve Only on the Inlet Side of the Safety Valves

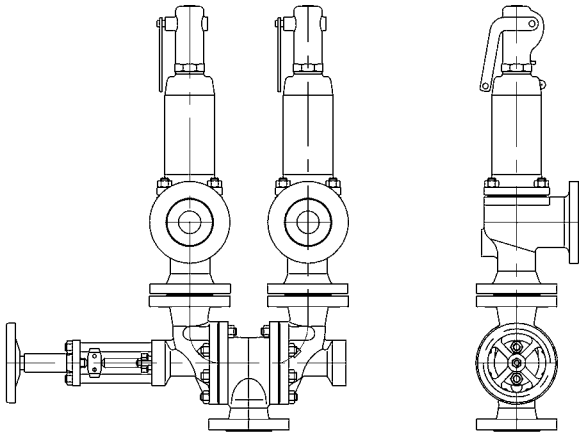

This arrangement is ideal for unrestricted discharge, either directly into atmosphere or into discharge piping or discharge containments.

### General:

The use of change over valves allows essential maintenance work to be carried out on a safety valve, without interruption of the plant operation, simply by changing over to the relevant standby valve, thus protecting the plant against excessive overpressure.

When operating the change over valve, it is necessary to ensure that the valve does not remain in any intermediate position. The respective part of the valve shall be fully open.

The WTA® Change Over Valves offer full flow across the complete stroke. Nonetheless, when operating the change over valve it is essential to always ensure complete shut off of one side. Change over valves shall not remain in an intermediate position while in operation.

### Sizing:

The change over valve at the inlet side of a combination of change over valves and safety valves causes during discharging a pressure drop. To guarantee the function of a safety valve the following rules for the sizing of change over valves should be taken into account.

### Change Over Valve Only at the Inlet of the Safety Valves:

**Standard safety valve:** the nominal inlet diameter of the standard safety valve refers to the nominal diameter of the change over valve.

**Full lift safety valve:** the nominal outlet diameter of the full lift safety valve determines the size of the change over valve. To connect

## Combination of Change Over Valves Type on the Inlet and Outlet Sides of Safety Valves

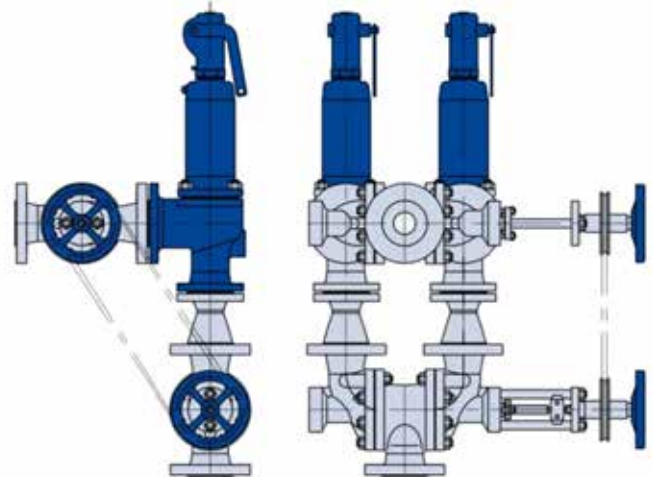

This combination of two change over valves is used for redirecting flow into a common piping behind the safety relief valves. The two change over valves are coupled by using sprocket wheels and a linking chain for interlocking purposes. During discharge back pressure is built up on the outlet side.

the safety valves both outlet flanges of the change over valves are reduced to match the inlet size of the safety valves. The WTA® Change Over Valves offer an extensive range of size reducers across all configurations and are thus able to meet special customer needs all around the globe. This includes customized assembly dimensions.

In case the service conditions do not require the maximum discharge capacity of the safety valve it can be considered to use a smaller sized change over valve as a more economic solution.

### Combination of Change Over Valves on the Inlet and Outlet Side of Safety Valves:

WTA® Change Over Valve combinations are offered with an interlocking system to ensure simultaneous operation of both change over valves and thus preventing unintended blocking of discharge.

**Standard safety valve:** usually the standard safety valve has the same nominal diameter at the inlet and outlet. The nominal diameter of the connected change over valves are adequate to them.

**Full lift safety valve:** the full lift safety valve has different nominal diameters at the inlet and outlet. The nominal diameter on the outlet determines the size of the change over valves. Therefore the change over valve at the inlet of the combination has also the same diameter as the change over valve at the outlet. But both outlet flanges of the change over valve are reduced to the nominal inlet diameter of the safety valve.

# How To Order Change Over Valves

## Example:

**11.8 - FL - 1.4408 - 65/40S - 40 - B1 - GS - KE - SP1 - ST - DI - SM - EB6 - Q61 - LA - FO**

COV Type	
11.7	COV with packing
11.75E	COV combination inlet side with packing
11.75A	COV combination outlet side with packing
11.8	COV with bellows
11.85E	COV combination inlet side with bellows
11.85A	COV combination outlet side with bellows

Flanges	
FL	flanges
SE	butt weld ends

Material	
1.0619	Carbon steel
1.4408	Stainless steel
1.6220	low temperature carbon steel (EN)
1.1138	low temperature carbon steel (DIN)
1.4470	Duplex
1.4539	High alloy
2.4858	High alloy
2.4819	High alloy
WCB	Carbon steel
CF8M	Stainless steel
CF8C	Stainless steel
CF3M	Stainless steel
LCB	low temperature carbon steel
LCC	low temperature carbon steel
**	Further Options

Sizes	
15 up to 500	
1/2" up to 20"	

Type of Reduction	
G	cast
S	welded

Pressure Class	
10 to 160	
Class 150 to class 2500	

Flange Facing*	
B1	
D	
C	
E	
F	
N	
B2	
L	
RJ	
RF	
LG	
LT	
LM	
LF	
SG	
ST	
SM	
SF	

Seat Options	
GS	Hard Facing

Plug Options	
KE	hard facing/material
KE1	plug material made out of Hastelloy C276
KE2	plug material made out of Hastelloy C4
KE3	plug material made out of Hastelloy C22
KE4	plug material made out of Monel
KE5	plug material made out of 1.4539

Stem Options	
SP1	lower stem part made out of Hastelloy C276
SP2	lower stem part made out of Hastelloy C4
SP3	lower stem part made out of Hastelloy C22
SP4	lower stem part made out of Monel 400

Packing Options	
graphite	
PTFE	
other	

Gasket Options	
graphite	
PTFE	
other	

Bolting Options	
S4	A4-70
SM	special

Options	
EB1	drain connection G, without plug screw (11.7/11.8)
EB2	drain connection G, with plug screw (11.7/11.8)
EB3	drain connection NPT, without plug screw (11.7/11.8)
EB4	drain connection NPT, with plug screw (11.7/11.8)
EB5	drain connection NPTF, without plug screw (11.7/11.8)
EB6	drain connection NPTF, with plug screw (11.7/11.8)

Options	
Q310	design according to QV0031-ÖF; oil & grease free for less critical applications
Q315	design according to QV0031-SF; oil & grease free & silicone free
Q61	design according to QV0061-O2; oil & grease free for oxygen service
Q71	design according to QV0071-EC; oil & grease free according to Euro Chlor
Q81	design according to QV0081-CL; oil & grease free for Chlorine service
Q91	design according to QV0091; oil & grease free & particle free
Q110	design according to QV0110; sour gas according to NACE MR0175
Q111	design according to QV0111; sour gas according to Total-Leuna standard

Painting Options	
LA	Special Painting

Other Options	
FO	packing in foil
FS1	operational security FS1: fixing construction for hand wheel (bolt & chain)
FS2	operational security FS2: fixing construction for hand wheel (U-lock)
(...)	(and more...)

\* DIN/EN/customized  
butt weld ends

- S10
- S40
- S80
- S160

\*\*Further Options

- 1.7357/WC6
- Alloy 400
- Alloy 825
- CW2M
- CM12MW
- 2.4360

## Accessories for Type 11.7, 11.75, 11.8, 11.85

- Gland packing special material
- Bonnet gasket special material 11.7
- Bonnet gasket special material 11.8
- Body gasket special material
- Different flange facings (DIN and ASME)

Valve types according to NACE MR 0175 for carbon and stainless steel grades cover the following details: limitation of hardness and chemical analysis as per NACE MR0175. Stress relief annealing following welding operations on carbon steel grades, marking with low-stress stamps.



**Drain hole without gasket and screw**

G $\frac{1}{4}$  female thread  
G $\frac{1}{2}$  female thread

**Screw 1.4571 with gasket DIN 7603 stainless steel for drain hole**

G $\frac{1}{4}$   
G $\frac{1}{2}$



**Flushing connection without gasket and screw**

Welded nipple

**Optional: Screw 1.4571 with gasket DIN 7603 stainless steel for flushing connection**

G $\frac{1}{4}$  / G $\frac{1}{2}$

## Accessories for Type 11.7, 11.75, 11.8, 11.85



**By-Pass with non return valves**  
2 valves DN15/PN40

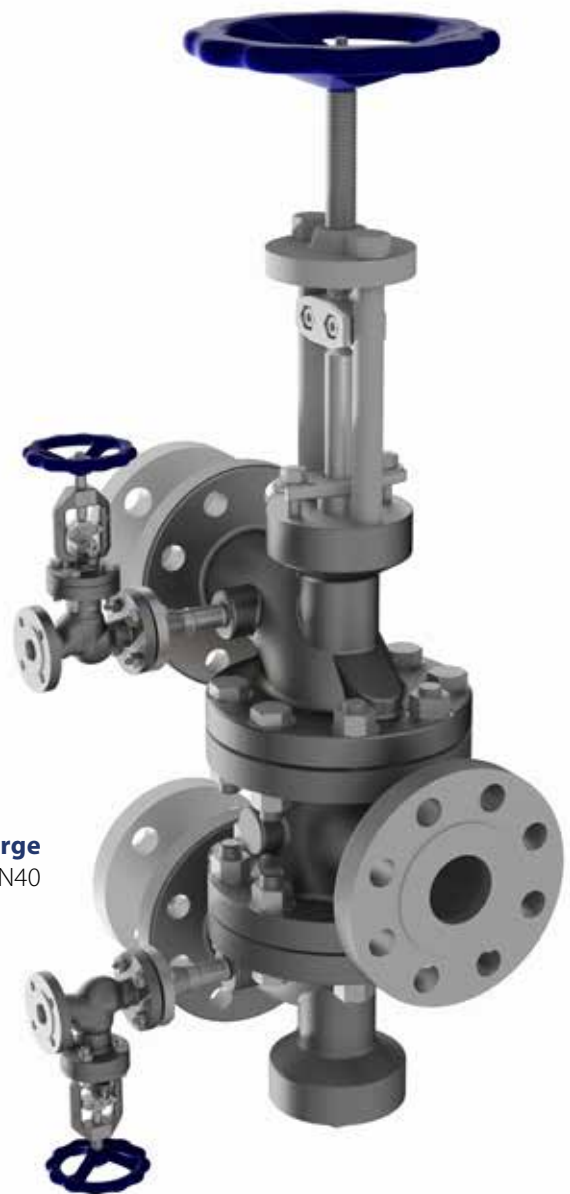

**Stop valve for pressure discharge**  
2 valves DN15/PN40

Accessories for Type 11.7, 11.75, 11.8, 11.85



**2 x Reducer (1/2/3 nominal diameter)**  
Welded reducers



**2 x Reducer (1/2/3 nominal diameter)**  
Cast reducers

**Accessories for Type 11.7, 11.75, 11.8, 11.85**



**Hand wheel locking device (FS1)**



**Hand wheel interlocking  
11.75/11.85**

**Lockable combination hand  
wheel, chainwheel and chain**



Crane ChemPharma & Energy  
 Xomox International GmbH & Co. OHG  
 Von-Behring-Straße 15  
 88131 Lindau/Bodensee  
 Germany  
 Tel: +49 8382-702-0  
 Fax: +49 8382-702-144  
 www.cranecpe.com

**CRANE**

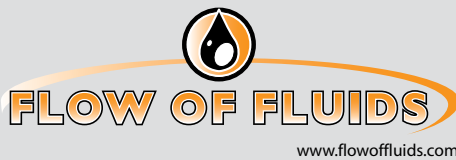

**brands you trust.**



**COMPAC-NOZ®**

**CRANE**

**DEPA®**

**ELRO® DUO-CHEK®**



**FK®**  
**KROMBACH**  
ARMATUREN

**NOZ-CHEK®**



**RESISTOFLEX®**



**Saunders®**  
the science inside

**STOCKHAM®**



**UNI-CHEK®**

**w.ta.®**

**XOMOX®**

Crane Co., and its subsidiaries cannot accept responsibility for possible errors in catalogues, brochures, other printed materials, and website information. Crane Co. reserves the right to alter its products without notice, including products already on order provided that such alteration can be made without changes being necessary in specifications already agreed. All trademarks in this material are property of the Crane Co. or its subsidiaries. The Crane and Crane brands logotype, in alphabetical order, (ALOYCO®, CENTER LINE®, COMPAC-NOZ®, CRANE®, DEPA®, DUO-CHEK®, ELRO®, FLOWSEAL®, JENKINS®, KROMBACH®, NOZ-CHEK®, PACIFIC VALVES®, RESISTOFLEX®, REVO®, SAUNDERS®, STOCKHAM®, TRIANGLE®, UNI-CHEK®, WTA®, and XOMOX®) are registered trademarks of Crane Co. All rights reserved.