



Level Electrodes

NRG 16-51

NRG 17-51

NRG 19-51

NRG 111-51

EN
English

Original Installation Instructions
818956-06

Contents

Page

Important notes

Usage for the intended purpose.....	4
Function.....	4
Safety note.....	4

Directives and standards

EU Pressure Equipment Directive 2014/68/EU.....	5
Functional Safety acc. to IEC 61508.....	5
VdTÜV Bulletin "Wasserstand 100" (= Water Level 100).....	5
ATEX (Atmosphère Explosible).....	5
Note on the Declaration of Conformity / Declaration by the Manufacturer CE	5

Technical data

NRG 16-51, NRG 17-51, NRG 19-51, NRG 111-51.....	6
Scope of supply.....	7
Name plate / marking.....	8

Installation

Dimensions NRG 16-51, NRG 17-51, NRG 19-51, NRG 111-51 with four-pole connector.....	9
Dimensions NRG 16-51F, NRG 17-51F, NRG 19-51F, NRG 111-51F with aluminium terminal box.....	10
NRG 16-51, NRG 17-51, NRG 19-51, NRG 111-51.....	12
NRG 16-51, NRG 17-51, NRG 19-51, NRG 111-51 step 1.....	13
NRG 16-51, NRG 17-51, NRG 19-51, NRG 111-51 step 2.....	13
Key.....	13
Tools.....	13
NRG 16-51F, NRG 17-51F, NRG 19-51F, NRG 111-51F with aluminium terminal box.....	14
NRG 16-51F, NRG 17-51F, NRG 19-51F, NRG 111-51F additional information.....	15
Key.....	15

Examples of installation

NRG 16-51, NRG 17-51, NRG 19-51.....	16
NRG 111-51.....	17
Key.....	17

Electrical connection

NRG 16-51, NRG 17-51, NRG 19-51, NRG 111-51 with four-pole connector.....	18
Key.....	18

Contents - continued -

Page

Electrical connection - continued -

Connection of level electrode	19
NRG 16-51, NRG 17-51, NRG 19-51, NRG 111-51 with four-pole connector	19
NRG 16-51F, NRG 17-51F, NRG 19-51F, NRG 111-51F with terminal box made from aluminium	19
Tools	19
Wiring diagram	20
Key	20

Commissioning, fault indication and troubleshooting21

Removing and disposing of the level electrode

Removing and disposing of level electrode NRG 1..-51	21
Removing and disposing of level electrode NRG 1..-51F	21

Important notes

Usage for the intended purpose

The level electrodes NRG 1...-51 are used in conjunction with level switch NRS 1-51 as high water level alarms for steam boiler plants and (pressurized) hot water installations.

A high level alarm prevents the water level from exceeding the preset max. water level (HW) and for this purpose switches off e. g. the feedwater supply.

Function

When the level exceeds the max. water level, the level electrode enters the liquid and an alarm is triggered in the level switch NRS 1-51. The switchpoint "High level (HW) exceeded" is dictated by the length of the electrode rod.

The electrode operation is based on the conductive measuring principle using the electrical conductivity of the water for signalling water level. The self-monitoring function ensures that an alarm will also be triggered if the electrode insulation is contaminated or has developed a leak or if there is a malfunction in the electrical connection.

The level electrode is installed inside steam boilers, vessels or inlet lines of hot-water systems. The protective tube mounted on site (see section **Examples of Installation** - pages 16, 17) ensures correct functioning.

One level electrode NRG 1...-51 can be installed together with one GESTRA water level limiting electrode in a single protection tube or external level pot.

If the level electrode is installed in a level pot outside the boiler, make sure that the connecting lines are rinsed regularly. In addition, the logic unit SRL is required to monitor the purging times and the purging sequence.

If the connecting lines for steam ≥ 40 mm and water ≥ 100 mm, the installation is considered to be internal. In this case the rinsing processes do not have to be monitored.

Safety note

High water level alarms are safety devices and must only be installed, wired and commissioned by qualified and competent staff.

Retrofitting and maintenance work must only be performed by qualified staff who - through adequate training - have achieved a recognised level of competence.



Danger

When loosening the electrode steam or hot water might escape!

This presents the risk of severe scalding all over the body!

It is therefore essential not to dismantle the electrode unless the boiler pressure is verified to be 0 bar.

The electrode becomes hot during operation.

Risk of severe burns to hands and arms.

Before carrying out installation and maintenance work make sure that the steam trap is cold.



Attention

The name plate specifies the technical features of the equipment. Do not commission or operate any item of equipment that does not bear its specific name plate.

Directives and standards

EU Pressure Equipment Directive 2014/68/EU

The level electrode NRG 1...-51 in conjunction with level switch NRS 1-51 is EC type approved according to EN 12952/EN 12953. These Directives state, among other things, the requirements made on limiting systems and equipment for steam boiler plants and (pressurised) hot-water installations.

Functional Safety acc. to IEC 61508

The level electrode NRG 1...-51 is certified acc. to IEC 61508 only if used in combination with level switch NRS 1-51. This standard describes the functional safety of safety-related electrical/electronic/programmable electronic systems.

The equipment combination NRG 1...-51 + NRS 1-51 corresponds to a type B subsystem with Safety Integrity Level (SIL) 3.

VdTÜV Bulletin "Wasserstand 100" (= Water Level 100)

The level electrodes NRG 1..-51, NRG 1...-12 in conjunction with the level switch NRS 1-51 are type approved according to the VdTÜV Bulletin "Water Level 100".

The VdTÜV Bulletin "Wasserstand (= Water Level) 100" specifies the requirements made on water level control and limiting equipment for boilers.

ATEX (Atmosphère Explosible)

The level electrodes NRG 1...-51, NRG 1...-12 are simple items of electrical equipment as specified in EN 60079-11 section 5.7. According to the European Directive 2014/34/EU the equipment must be equipped with approved Zener barriers if used in potentially explosive areas. Applicable in Ex zones 1, 2 (1999/92/EC). The equipment does not bear an Ex marking.

Note that the requirements of the IEC 61508 are not met if the NRG 1...-51, NRG 1...-12 + Zener barriers + NRS 1-51 are interconnected!

Note on the Declaration of Conformity / Declaration by the Manufacturer C€

For details on the conformity of our equipment according to the European Directives see our Declaration of Conformity or our Declaration of Manufacturer.

The current Declaration of Conformity / Declaration of Manufacturer are available in the Internet under www.gestra.en/documents or can be requested from us.

Technical data

NRG 16-51, NRG 17-51, NRG 19-51, NRG 111-51

Service pressure

NRG 16-51: PN 40, 32 bar at 238 °C

NRG 17-51: PN 63, 46 bar at 260 °C

NRG 19-51: PN 160, 100 bar at 311 °C

NRG 111-50: PN 320, 183 bar at 357 °C

Mechanical connection

Screwed G $\frac{3}{4}$ A, ISO 228 (NRG 16-51, NRG 17-51, NRG 19-51)

Screwed G 1 A, ISO 228 (NRG 111-51)

Materials

Screw-in body 1.4571 X6CrNiMoTi17-12-2 (NRG 16-51, NRG 17-51, NRG 19-51)

Screw-in body 1.4529 X1NiCrMoCuN25-20-7 (NRG 111-51)

Measuring electrode 1.4571 X6CrNiMoTi17-12-2 (NRG 16-51, NRG 17-51, NRG 19-51)

Measuring electrode 1.4122 X39CrMo17-1 (NRG 111-51)

Electrode extension 1.4401 X5CrNiMo17-12-2

Electrode insulation PEEK (NRG 16-51, NRG 17-51, NRG 19-51)

Electrode insulation special ceramic (NRG 111-51)

NRG 1...-51: Four-pole connector: polyamide (PA)

NRG 1...-51F: Terminal box 3.2161 G AISi8Cu3

Lengths supplied

500 mm, 1000 mm, 1500 mm

pH value

Max. admissible: 10 (only NRG 111-51)

Electrical conductivity

Max. admissible: 100 μ S/cm at 25 °C (only NRG 111-51)

Electrical connection

NRG 1...-51: Four-pole connector, cable glands M 16

NRG 1...-51 F: Terminal box made from aluminium, cable gland M 20

Protection

IP 65 to EN 60529

Max. admissible ambient temperature

70 °C

Weight

Approx. 1.2 kg (without extension) (NRG 16-51, NRG 17-51, NRG 19-51)

Approx. 2.1 kg (without extension) NRG 16-51F, NRG 17-51F, NRG 19-51F)

Approx. 1.8 kg (without extension) (NRG 111-51)

Approx. 2.7 kg (without extension) NRG 111-51F)

Technical Data - continued -

NRG 16-51, NRG 17-51, NRG 19-51, NRG 111-51 - continued -

Approvals

EC Prototype approval	PED Pressure Equipment Directive 2014/68/EU, EN 12952-11, EN 12953-09: Requirements made on limiting equipment for boilers.
Functional Safety SIL 3	IEC 61508: Functional safety of safety-related electrical/electronic/programmable/electronic systems
TÜV certificate	VdTÜV Bulletin "Water Level 100" Requirements made on water level limiting & control equipment. Type approval no. TÜV · SHWS · xx-423 (see name plate)

Scope of supply

NRG 16-51

- 1 Level electrode NRG 16-51, PN 40
- 1 Joint ring 27 x 32, form D, DIN 7603, 2.4068, bright annealed
- 1 Washer with set screw (measuring surface extension) (optional)
- 1 Retaining ring (optional)
- 1 Installation manual

NRG 17-51

- 1 Level electrode NRG 17-51, PN 63
- 1 Joint ring 27 x 32, form D, DIN 7603, 2.4068, bright annealed
- 1 Washer with set screw (measuring surface extension) (optional)
- 1 Retaining ring (optional)
- 1 Installation manual

NRG 19-51





- 1 Level electrode NRG 19-51, PN 160
- 1 Joint ring 27 x 32, form D, DIN 7603, 2.4068, bright annealed
- 1 Washer with set screw (measuring surface extension) (optional)
- 1 Retaining ring (optional)
- 1 Installation manual

NRG 111-51

- 1 Level electrode NRG 111-51, PN 320
- 1 Joint ring 33 x 39, form D, DIN 7603, 2.4068, bright annealed
- 1 Washer with set screw (measuring surface extension) (optional)
- 1 Retaining ring (optional)
- 1 Installation manual

Technical Data - continued -

Name plate / marking

Equipment designation			Safety note			
NRG 16-51 			 Betriebsanleitung beachten See installation instructions Voir instructions de montage			 Disposal note
PN 40	G 3/4	1.4571 IP 65	TÜV . SHWS . xx-423			 CE Marking
 32 bar (464psi) 238°C (460°F) T amb = 70°C (158 °F)						
GESTRA AG • D-28215 Bremen						0525
Manufacturer			Serial number			





NRG 111-51 			 Betriebsanleitung beachten See installation instructions Voir instructions de montage			
G 1	1.4529	IP 65	TÜV . SHWS . xx-423			
 180 bar (2609psi) 357°C (675°F) T amb = 70°C (158 °F)						
GESTRA AG • D-28215 Bremen						0525

Fig. 1











 Betriebsanleitung beachten See installation instructions Voir instructions de montage	 Betriebsanleitung beachten See installation instructions Voir instructions de montage	Safety note
 Hier öffnen Open here Ouvrir ici	 Hier öffnen Open here Ouvrir ici	
NRG 16 – 51 F PN 40 <input type="checkbox"/>	NRG 111 – 51 F	Equipment designation, pressure rating
NRG 17 – 51 F PN 63 <input type="checkbox"/>	G 1 1.4529 IP65	Screwed connection, material number, protection
NRG 19 – 51 F PN160 <input type="checkbox"/>	 180 bar (2609psi) 357°C (675°F)	Pressure/temperature rating
G 3/4 1.4571 IP65	 Tamb = 70°C (158 °F)	
 46 bar (667psi) 260°C (500°F)	TÜV . SHWS . xx-423	CE Marking, type approval
100 bar (1450psi) 311°C (592°F)	 0525	
 Tamb = 70°C (158°F)	GESTRA AG	Disposal note
TÜV . SHWS . xx-423	Münchener Str. 77 D-28215 Bremen	Manufacturer
 0525		
GESTRA AG Münchener Str. 77 D-28215 Bremen		Serial number

Fig. 2

Installation

Dimensions NRG 16-51, NRG 17-51, NRG 19-51, NRG 111-51 with four-pole connector

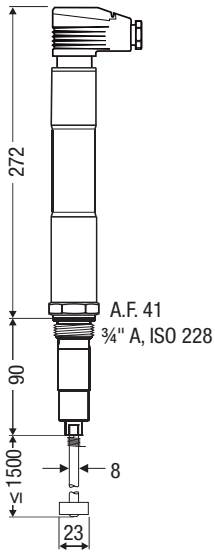

Fig. 3
NRG 16-51, NRG 17-51
with measuring surface extension

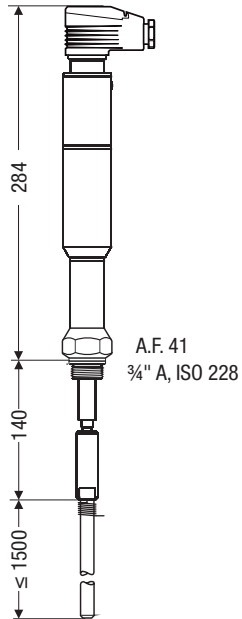

Fig. 4
NRG 19-51

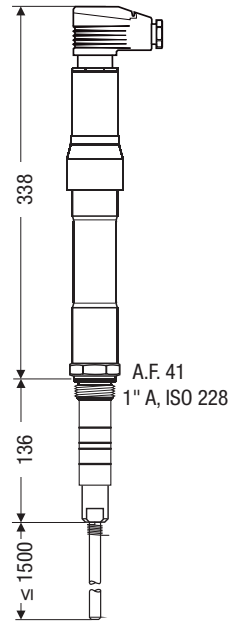

Fig. 5
NRG 111-51

Dimensions NRG 16-51F, NRG 17-51F, NRG 19-51F, NRG 111-51F with aluminium terminal box

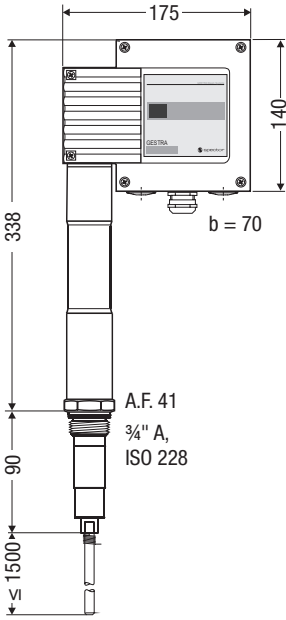

Fig. 6
NRG 16-51F, NRG 17-51F

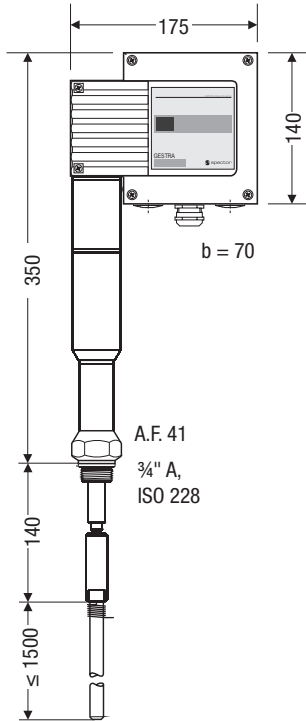

Fig. 7
NRG 19-51F

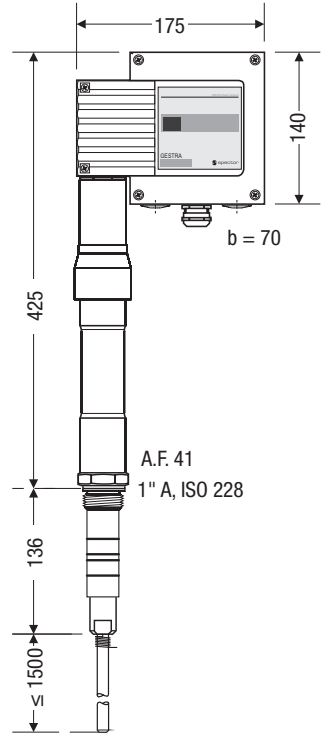

Fig. 8
NRG 111-51F



Note

- **One** level electrode NRG 1...-51 can be installed together with one GESTRA level electrode, one level switch or transmitter for water level control and high level alarm in one single protection tube or level pot (inside diameter 100 mm.) **Fig. 18.** If an electrode for water level limiting type NRG 1...-50 is installed inside the vessel, it must be at least 40 mm away from the upper vent hole.
- For the approval of the boiler standpipe the relevant regulations must be considered.
- Refer to pages 16 and 17 for typical installation examples.
- The angle of inclination of the electrode must not exceed 45°, with the length of the electrode being limited to 1000 mm. **Fig. 17**
- If used in combination with level switch NRS 1-51 with a response sensitivity of 0.5 µS/cm please use a measuring surface extension.
- For outdoor installations please use level electrode NRG 1...-51 F. Level electrodes with this suffix (F) feature a terminal box made from aluminium.



Attention

- The seating surfaces of the standpipe or the flange provided on the vessel must be accurately machined, see **Fig. 13.**
- Do not bend electrode tip when mounting.
- Use only the joint rings supplied with the electrode.
NRG 16-51, NRG 17-51, NRG 19-51: 27 x 32, form D, DIN 7603, 2.4068
NRG 111-51: 33 x 39, form D, DIN 7603, 2.4068
- Do not lag electrode body above the hexagonal section.
- Do not insulate electrode thread with hemp or PTFE tape!
- Do not apply conductive paste or grease to the electrode thread!
- Make sure that the air distance between the electrode rod and earth (flange, vessel wall) is not less than 14 mm. **Fig. 16-22**
- Observe the minimum distances for the installation of the electrode!
- If the level electrode **NRG 111-51** is to be installed in a flanged standpipe DN 50 use only the GESTRA hat flange! **Fig. 12**
- When using the level electrode **NRG 111-51** take the pH limit value (10) and the max. admissible electrical conductivity (100 µS/cm at 25 °C) into consideration.

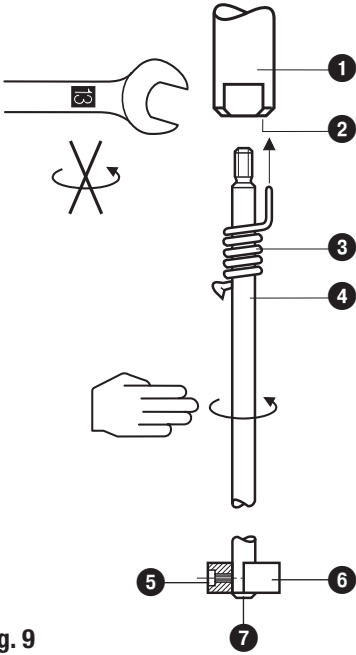

Fig. 9

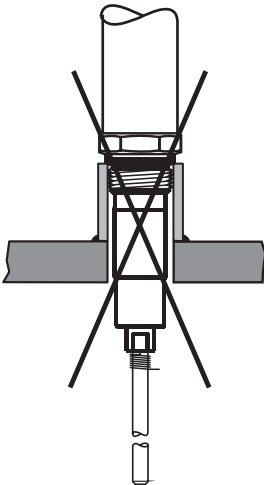

Fig. 11
NRG 16-51
NRG 17-51
NRG 19-51

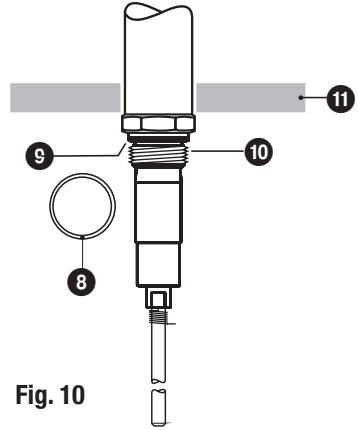

Fig. 10

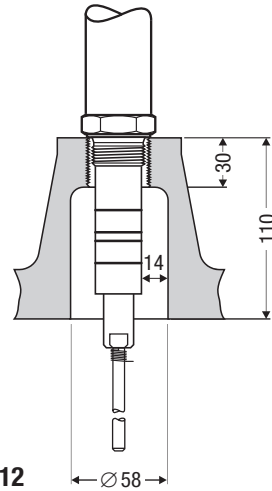

Fig. 12
NRG 111-51

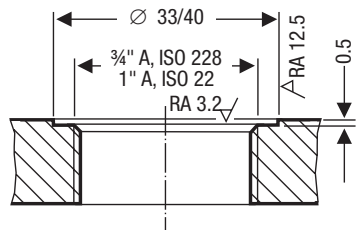

Fig. 13

NRG 16-51, NRG 17-51, NRG 19-51, NRG 111-51 step 1

1. Screw electrode tip ④ into measuring electrode ①. **Fig. 9**
2. Carefully determine required measuring length of electrode. Observe minimum length.
3. Mark length of electrode tip ④.
4. Unscrew electrode tip ④ from measuring electrode ① and cut tip.
5. After visual inspection screw electrode tip ④ into measuring electrode ①. Slide spring ③ along electrode tip ④ so that its end completely enters the small hole ②.
6. Mounting the measuring surface extension: Fit disk ⑥ to electrode tip, making sure that the electrode tip protrudes 2 mm beyond the bottom of the surface extension disk. Fix the disk in this position with the set screw ⑤. Push supplied lock washer ⑦ from below over electrode tip and against surface extension disk ⑥.

NRG 16-51, NRG 17-51, NRG 19-51, NRG 111-51 step 2

7. Check seating surfaces. **Fig. 13**
8. Place supplied joint ring ⑧ onto seating surface of the threaded standpipe or flange. **Fig. 13**
9. Apply a light smear of heat resistant silicone grease (e.g. WINIX® 2150) to electrode thread ⑩.
10. Screw level electrode into threads or flange provided on vessel and tighten with a 41 mm open-end spanner. The torque required **when cold is 160 Nm** (NRG 16-51, NRG 17-51, NRG 19-51) or **475 Nm** (NRG 111-51).

Key

- | | |
|------------------------------------|---|
| ① Measuring electrode | ⑧ NRG 1...-51: Joint ring 27 x 32, form D, DIN 7603, 2.4068, bright annealed
NRG 111-51: Joint ring 33 x 39, form D, DIN 7603, 2.4068, bright annealed |
| ② Bore | |
| ③ Spring | |
| ④ Electrode tip | ⑨ Seating surface |
| ⑤ Set screw | ⑩ Electrode thread |
| ⑥ Measuring surface extension disk | ⑪ Thermal insulation, d = 20 mm
(outside of thermal insulation of steam boiler) |
| ⑦ Retaining ring | |

Tools

- | | |
|---|---|
| ■ Open-end spanner A. F. 13, DIN 3110, ISO 3318 | ■ Scriber |
| ■ Open-end spanner A. F. 19, DIN 3110, ISO 3318 | ■ Hacksaw |
| ■ Open-end spanner A. F. 41, DIN 3110, ISO 3318 | ■ Flat file, medium cut, DIN 7261, form A |

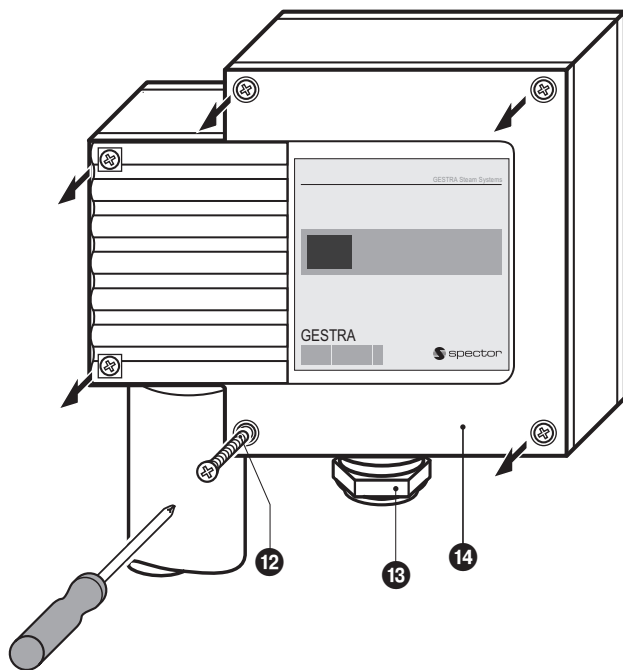

Fig. 14

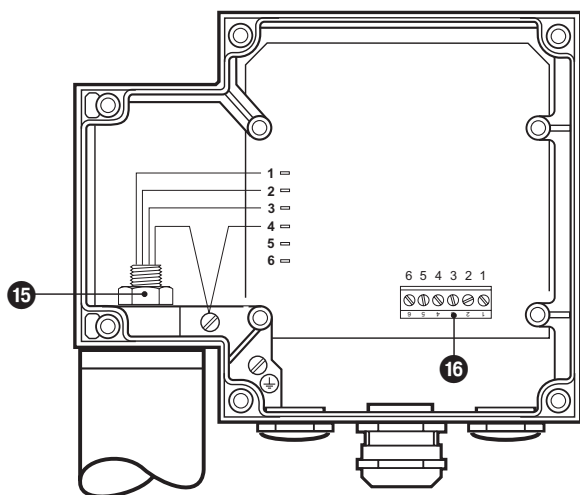

Fig. 15

NRG 16-51F, NRG 17-51F, NRG 19-51F, NRG 111-51F additional information

One level electrode NRG 1...-51F can be installed together with one GESTRA level electrode (with aluminium terminal box) in a single protection tube or external level pot.

Please proceed as follows:

1. Mount level electrode NRG 1...-51F as first device as described in step 2, items 7 - 10.

When installing level electrode NRG 1...-51F, please observe the following instructions:

1. Loosen screws **12** and remove housing cover **14**, **Fig. 14** The arrow on the name plate points towards this cover.
2. Loosen nut **15** with 19 mm open-end spanner but do not remove! **Fig. 15**
3. Turn electrode terminal box into desired direction (+/-180°).

The terminal box can be turned through +/-180°.

4. Tighten nut **15** with a torque of **25 Nm**.
5. Mount housing cover **14** and tighten screws **12**.

Key

- 12** Housing screws M 4
- 13** Cable gland M 20 x 1.5
- 14** Housing cover
- 15** Nut
- 16** Terminal strip

Examples of installation

NRG 16-51, NRG 17-51, NRG 19-51

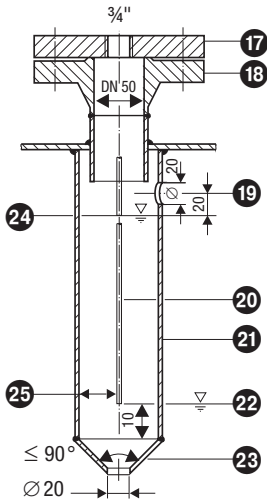

Fig. 16 Protection tube (provided on site) if electrode is used as internal water-level limiter

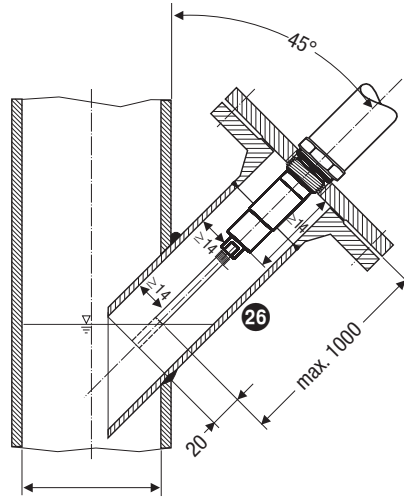

Fig. 17 Inclined installation, e. g. in ascending inlet lines of hot-water installations or vessels. Standpipe/connecting flange DN 50

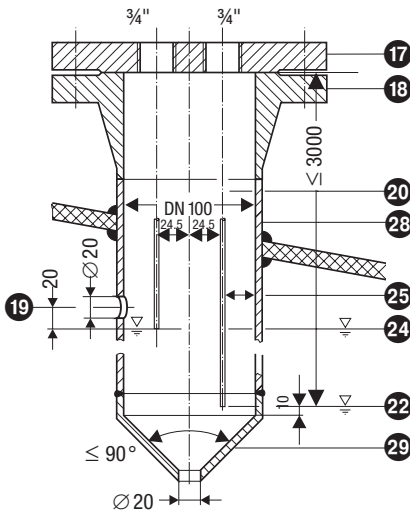

Fig. 18 Protection tube (provided on site) if electrode is used as internal water level-limiter combined with water level control or high water level alarm

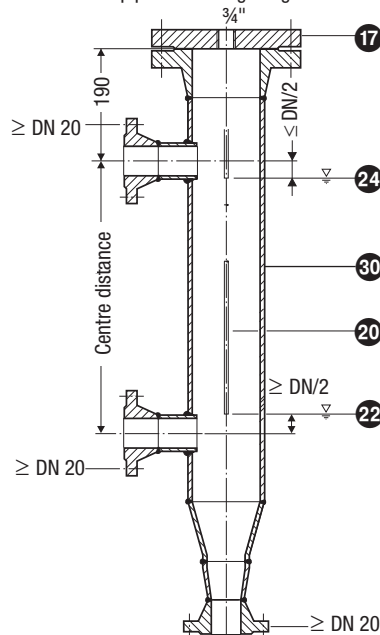

Fig. 19 Protection tube if electrode is used as external high level alarm

Examples of Installation - continued -

NRG 111-51

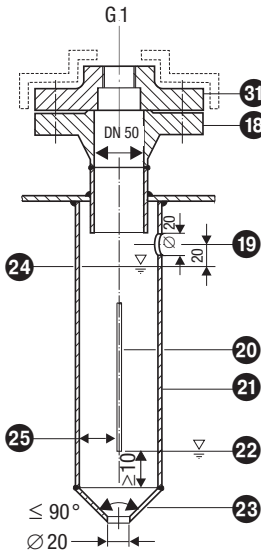

Fig. 20 Protection tube (provided on site) if electrode is used as internal water-level limiter

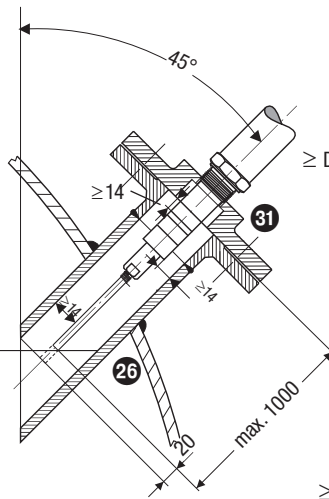

Fig. 21 Inclined installation, e.g. in steam boiler standpipe/ connecting flange DN50

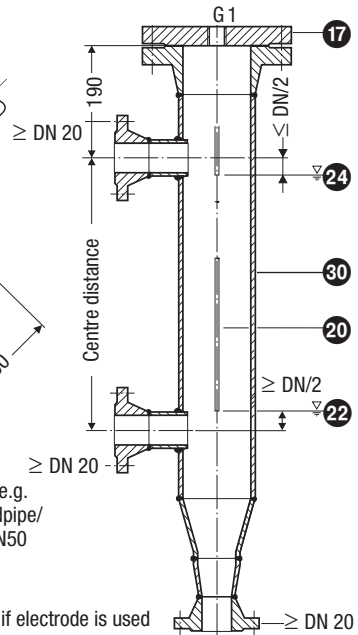

Fig. 22 Protection tube if electrode is used as external high level alarm

Key

- 17** Flange PN 40, PN 63, PN 160, PN 320, DN 50, DIN EN 1092-01 (for one electrode)
Flange PN 40, PN 63, PN 160, DN 100, DIN EN 1092-01 (for two electrodes)
- 18** For the approval of the boiler standpipe with connecting flange the relevant regulations must be considered.
- 19** Vent hole
Provide vent hole as close to the boiler wall as possible!
- 20** Electrode tip $d = 8$ mm
- 21** Protection tube DN 80 (in France according to AFAQ \geq DN 100)
- 22** Low water LW
- 23** Reducer DIN 2616-2, K-88.9 x 3.2-42.4 x 2.6 W
- 24** High water HW
- 25** Electrode distance ≥ 14 mm (air gap and creepage distance)
- 26** Standpipe / connecting flange DN 50
- 27** Thermal insulation, provided on site, $d = 20$ mm (outside of thermal insulation of steam boiler)
- 28** Protection tube DN 100
- 29** Reducer DIN 2616-2, K-114.3 x 3.6-48.3 x 2.9 W
- 30** Level pot \geq DN 80
- 31** GESTRA hat flange PN 320, DN 50, DIN EN 1092-01

Electrical connection

NRG 16-51, NRG 17-51, NRG 19-51, NRG 111-51 with four-pole connector

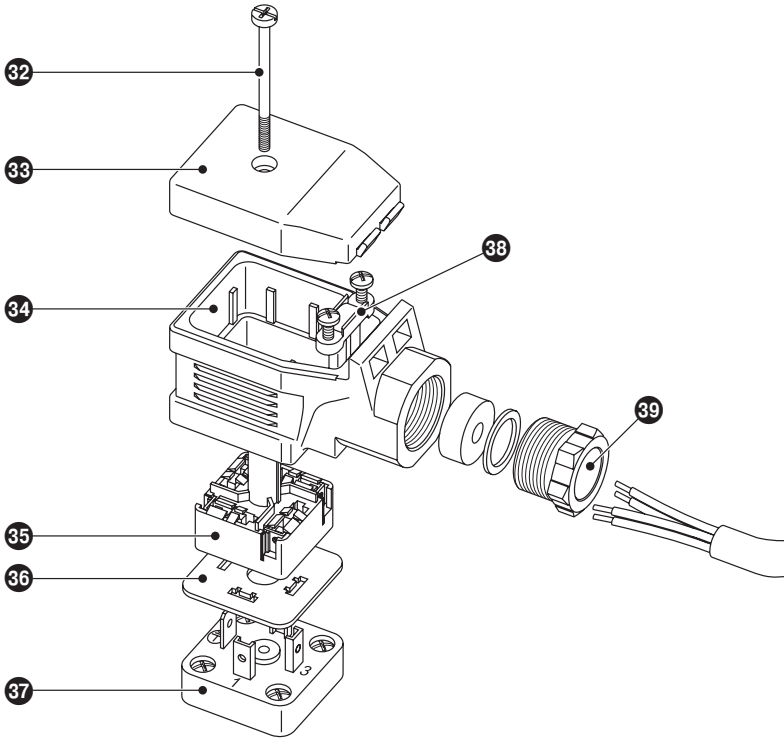

Fig. 23

Key

- | | | | |
|----|----------------------------|----|-----------------------------------|
| 32 | Screw M 4 | 36 | Insulating plate |
| 33 | Cover | 37 | Contact plate for level electrode |
| 34 | Upper part of terminal box | 38 | Cable clamp |
| 35 | Connecting plate | 39 | Cable gland M 19 (PG 11) |

Connection of level electrode

To connect the level electrode(s) please use:

- For the level switch NRS 1-51 with a response sensitivity of 10 µS:
Multi-core screened control cable, min. conductor size 0.5 mm², e. g. LiYCY 4 x 0.5 mm², max. length 100 m.
- For the level switch NRS 1-51 with a response sensitivity of 0.5 µS:
Multi-core double-screened low-capacitance data cable, min. conductor size 0.5 mm²,
Li2YCY PiMF 2 x 2 x 0.5 mm², max. length 30 m.

Wire terminal strip in accordance with the wiring diagram. **Fig. 24.** Wire the screens to terminal 5 and the central earthing point (**CEP**) in the control cabinet.

NRG 16-51, NRG 17-51, NRG 19-51, NRG 111-51 with four-pole connector

1. Loosen screw 32. **Fig. 23**
2. Remove upper part 34 of the terminal box from the level electrode but leave insulating plate 36 on contact plate 37.
3. Remove cover 33.
4. Press connecting plate 35 out of the upper part of the terminal box 34.
The upper part of the terminal box can be turned in steps of 90°.
5. Detach cable gland 39 and cable clamp 38 from the upper part of the terminal box 34.
6. Run cable through cable gland 39 and upper part of the terminal box 34 and wire terminals of the connecting plate 35 in accordance with wiring diagram.
7. Press connecting plate 35 into the upper part of the terminal box and align cable.
8. Fix cable with cable clamp 38 and cable gland 39 firmly into position.
9. Replace cover 33 and insert screw 32.
10. Put upper part of the terminal box onto the level electrode and fix it with screw 32.

NRG 16-51F, NRG 17-51F, NRG 19-51F, NRG 111-51F with terminal box made from aluminium

1. Loosen screws 12 and remove housing cover 14. **Fig. 14, 15**
2. Loosen cable gland 13. Pull cable through cable entry.
3. Remove terminal strip 16 from board.
4. Connect terminal strip according to the wiring diagram.
5. Attach terminal strip.
6. Tighten the cable gland in order to seal the cable entry. Use the supplied sealing plug to seal off the unused cable entry and tighten the cable gland.
7. Mount housing cover 14 and tighten screws 12.

Tools

- Screwdriver size 1
- Screwdriver size 2.5, completely insulated to DIN VDE 0680-1
- Open-end spanner A. F. 18 (19)

Wiring diagram

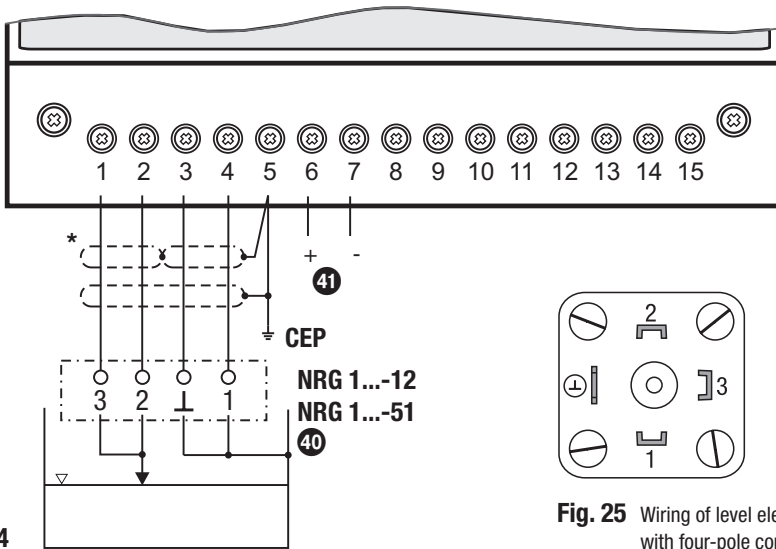

Fig. 24

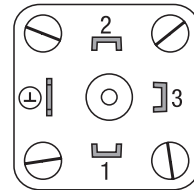

Fig. 25 Wiring of level electrode with four-pole connector

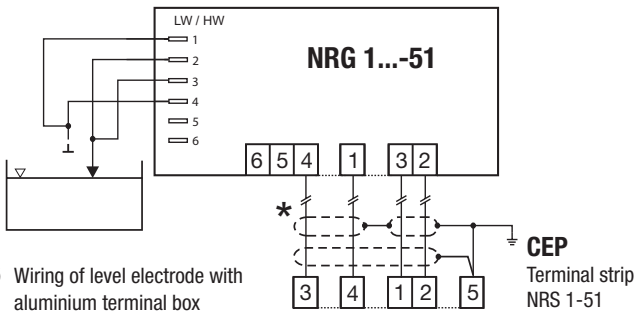

Fig. 26 Wiring of level electrode with aluminium terminal box

* NRS 1-51 with response sensitivity 0.5 µS/cm: Connect the two internal screens to terminal 5 and the CEP.

Key

- ④ Level electrode NRG 1..-51, NRG 1..-12
- ④ Stand-by input 1, 24 VDC, for connecting logic unit SRL
- CEP Central earthing point in control cabinet

Commissioning, fault indication and troubleshooting

For additional information on commissioning procedures and troubleshooting refer to the installation manual of the level switch NRS 1-51.

Removing and disposing of the level electrode



Danger

When loosening the electrode steam or hot water might escape!

This presents the risk of severe scalding all over the body!

It is therefore essential not to dismantle the electrode unless the boiler pressure is verified to be 0 bar.

The electrode becomes hot during operation.

Risk of severe burns to hands and arms.

Before carrying out installation and maintenance work make sure that the steam trap is cold.

Removing and disposing of level electrode NRG 1..-51

1. Loosen screw **32**. **Fig. 23**
 2. Detach upper part of the terminal box **34** from the level electrode.
 3. Before removing the equipment make sure that it is neither hot nor under pressure.
- For the disposal of the equipment observe the pertinent legal regulations concerning waste disposal.

Removing and disposing of level electrode NRG 1..-51F

1. Loosen screws **12** and remove housing cover **13**. **Fig. 14, 15**
 2. Unplug connecting cables from terminal strip and pull cables out of the cable gland.
 3. Before removing the equipment make sure that it is neither hot nor under pressure.
- For the disposal of the equipment observe the pertinent legal regulations concerning waste disposal.

If faults occur that are not listed above or cannot be corrected, please contact our service centre or authorized agency in your country.



Agencies all over the world: **www.gestra.de**

GESTRA AG

Münchener Straße 77

28215 Bremen

Germany

Telefon +49 421 3503-0

Telefax +49 421 3503-393

E-mail info@de.gestra.com

Web www.gestra.de