

# Desuperheater



# Purpose & Advantages

The ARTES desuperheater is a control valve with which the temperature of vapour can be regulated by injecting cooling water. The ARTES desuperheater is frequently used in steam generators of power plants and other industrial systems. Special applications using other media have also been realised.

By nature of its design and use of quarter-turn movement, the ARTES desuperheater offers many crucial advantages:

- ▶ The cooling water is always injected into the centre of the pipe, regardless of the quantity.
- ▶ The perfect combination of quarter-turn principle, nozzle design and subsequent nozzle opening ensures reliable and precise cooling in all load cases.
- ▶ Both its design and the use of high-grade materials prevent vibration fractures of the valve's functional components and ensure a reliable operation without interruptions.



- ▶ With its high rangeability, the ARTES desuperheater offers an outstanding quality of control. The control performance is continuous across the entire control range.
- ▶ The valve is permanently leak-tight to the outside.

The ARTES desuperheater can be actuated by means of electric, pneumatic or hydraulic actuators.



# Function

In contrast to other valves that operate according to stroke principle, the ARTES desuperheater utilises a quarter-turn movement.

The quantity of water to be injected is controlled by turning the valve stem by 90°. An additional control valve, as is necessary when using fix, uncontrolled nozzles, is not required here.

As the valve stem is turned, the ball contour located directly behind the water connection opens and the flow to the desuperheater lance is enabled. Water flows through the hollow nozzle stem and reaches the various nozzles through openings in the nozzle stem. These openings are designed in such a way that there are no 'steps' in the characteristic curve of the valve.

Swirl inserts in the nozzles cause the water to rotate. As a result of the water rotation and nozzle geometry, the spray cone is uniform, with very fine atomisation of the cooling water.

By using nozzles with different borehole diameters, any characteristic curve is possible – fine-tuned to the respective application.

The perfect combination of quarter-turn movement, nozzle design and subsequent nozzle opening ensures reliable and precise cooling in all load cases. To achieve a very wide and fine water distribution, the maximum possible number of nozzles is always used. Here, the maximum number of nozzles is directly dependent on the inner diameter of the steam pipe.

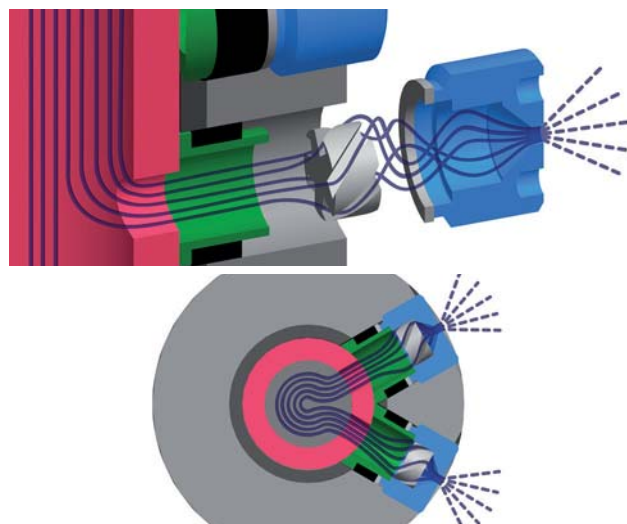
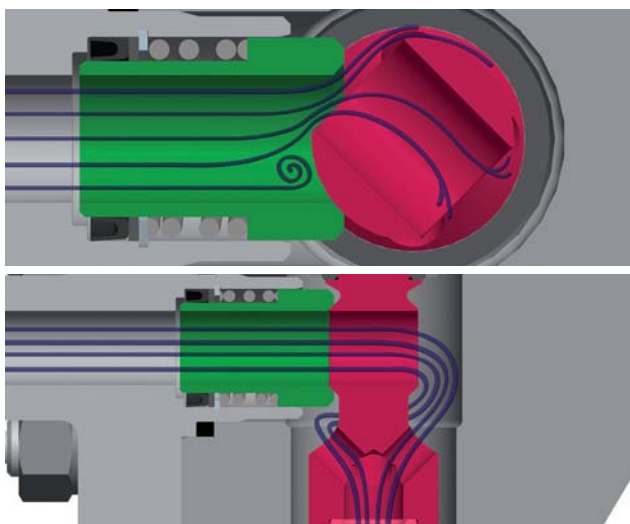
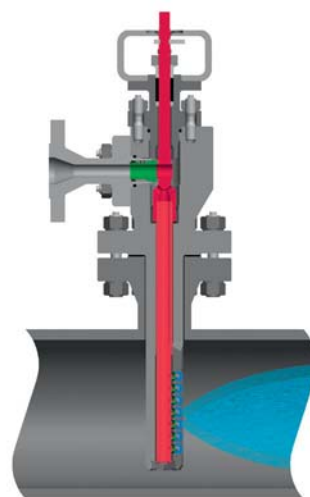

# Design

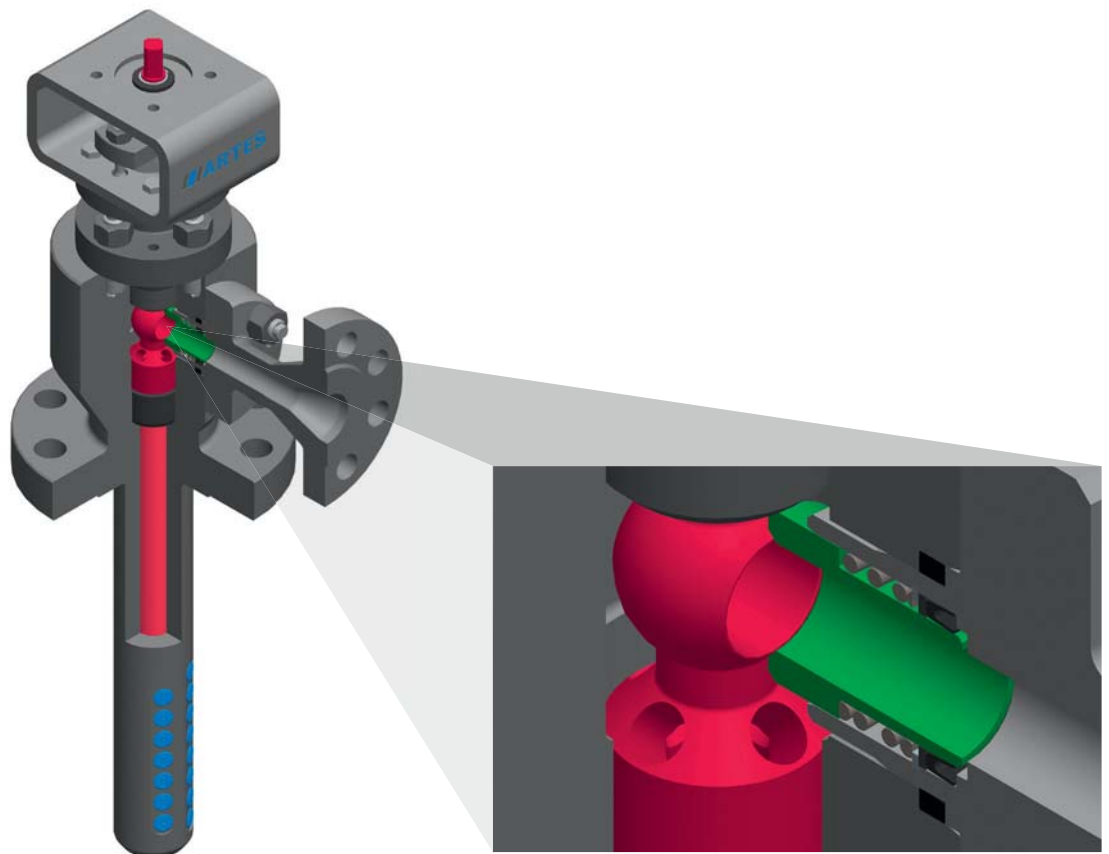

Depending on the pressure difference between cooling water and steam, the ARTES desuperheater is equipped with a single-, two- or three-stage pressure reduction.

The version with single-stage pressure reduction is used in cases where the differential pressure between cooling water and steam is in a range of 5 to 30 bar. The entire differential pressure is effective at the nozzle systems, due to the very low pressure loss within the desuperheater. This guarantees the very fine atomisation of the water. The ball/seat ring system is only used for shutting off the water.

For higher pressure differences between 30 and 60 bar, the desuperheater reduces the pressure in 2 stages. In this version, the ball and seat ring additionally have a control and throttle function (control contour in the ball passage). The three-stage version for pressure differences of more than 60bar the desuperheater has additional internals at the ball stem area to reduce over-pressure.

The ball/seat ring system is a pure metal-to-metal seat and works similar to a conventional ball valve.

# Design

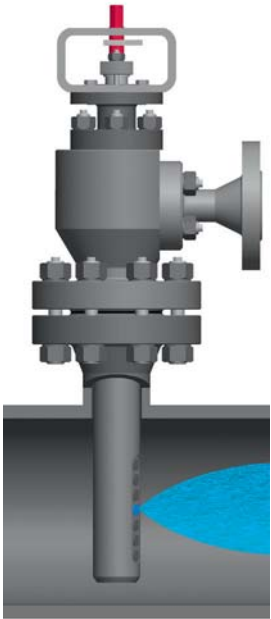

Optimal injection location:  
The nozzle that opens first is located in the middle of the steam line.

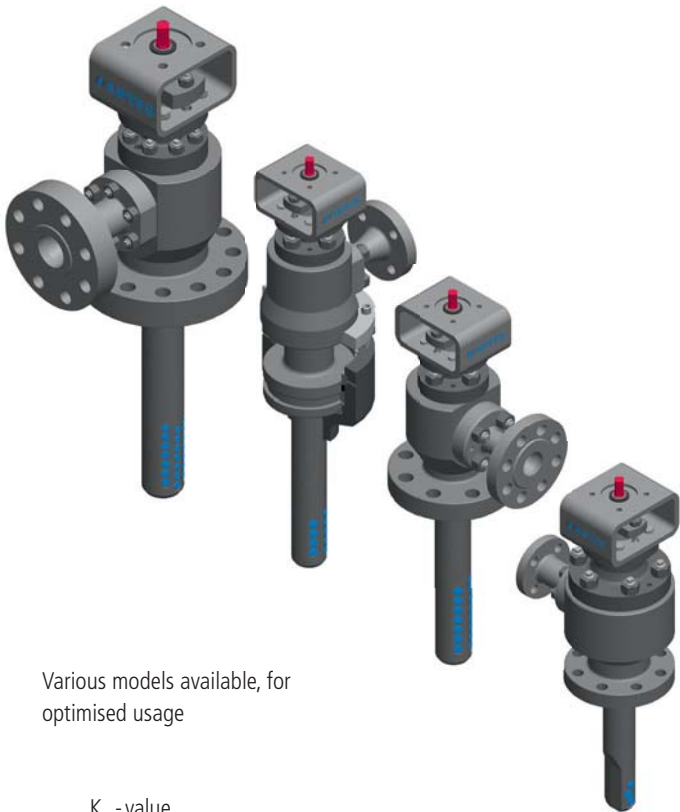

Various models available, for  
optimised usage

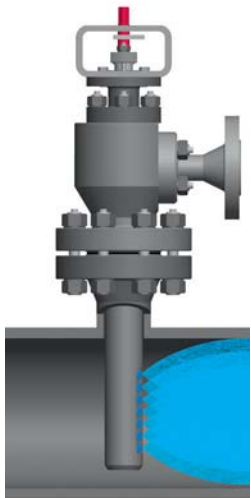

The order in which the nozzles open is determined by the design of the nozzle stem. After opening the first nozzles in the middle the next nozzles located at the outside areas are opened subsequently.

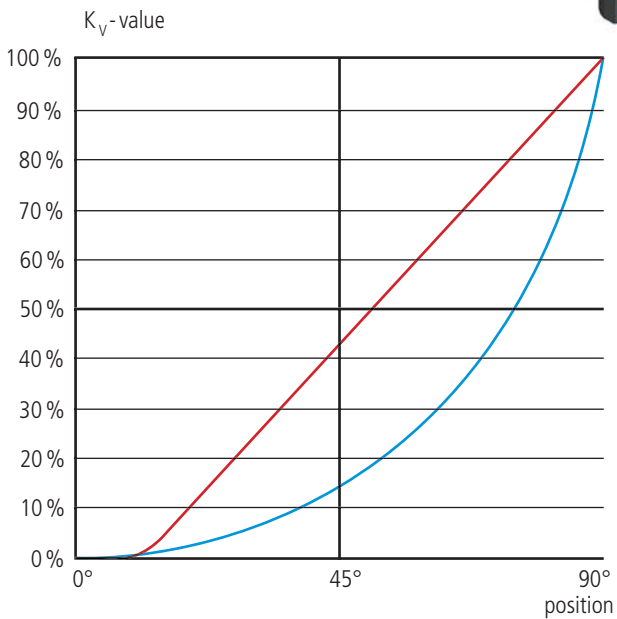

Examples for achievable control characteristics  
characteristics ■ linear ■ equal percentage

# Design

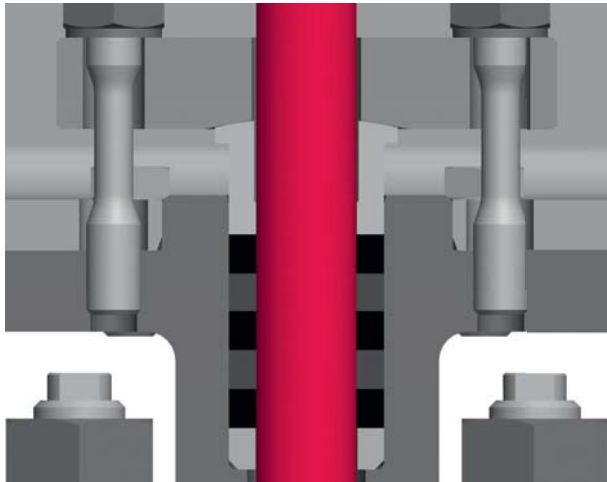

Permanently leaktight to the outside: The quarter-turn movement prevents dirt from being pulled into the packing.

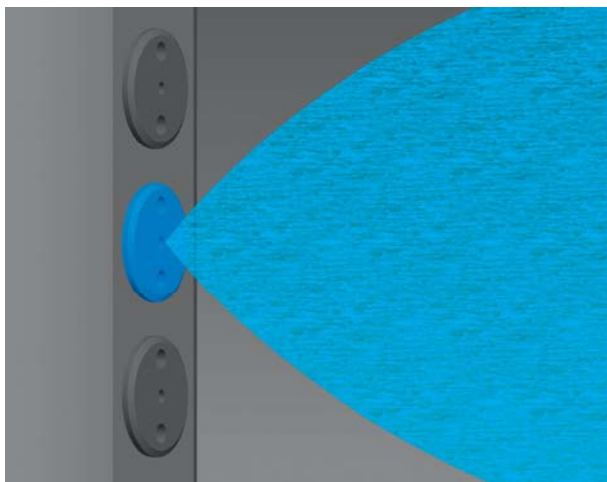

No cross-flow: The leak-tightness between the nozzles is safeguarded by metallic sealing elements. The control of every individual nozzle, based on the current operating conditions, allows precise temperature control in accordance with the specified control curve.

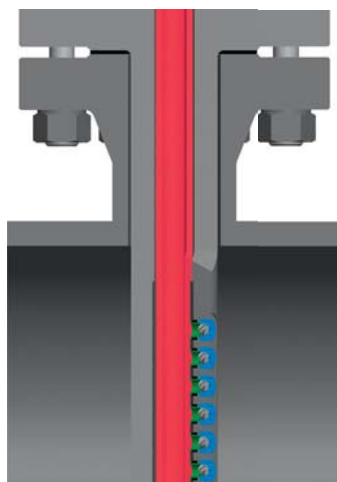

No vibration fractures: Contrary to stroke valves, no forces or torques act on the stem after it has been positioned. The flow through the hollow nozzle stem provides additional protection.

One-piece desuperheater lance: The nozzles are integrated into the forged housing. There is no separate nozzle head as is the case in valves that use the stroke principle.

# Facts

<b>Steam pipe:</b>	≥ DN150 or 6"
<b>Temperatures:</b>	up to 620°C
<b>Pressure levels:</b>	Max. PN400 or ANSI class 2500
<b>Body material:</b>	1.0460, 1.5415, 1.7335, 1.7380, 1.4903, 1.4541, 1.4571 or equivalent ASME materials
<b>Standards:</b>	Pressure Equipment Directive 97/23/EC, ASME, TRD, AD2000, EN standards
<b>Steam pipe connection:</b>	Flange connection: EN1092-1 or ASME B16.5, buttweld ends
<b>Injection volume (water):</b>	0 ... 80 t/h
<b>Pressure difference: water / steam</b>	optimal: approx. 5 to 90 bar
<b>Standard versions with:</b>	3, 6, 9, 12, 15, 18, 21 or 24 nozzles

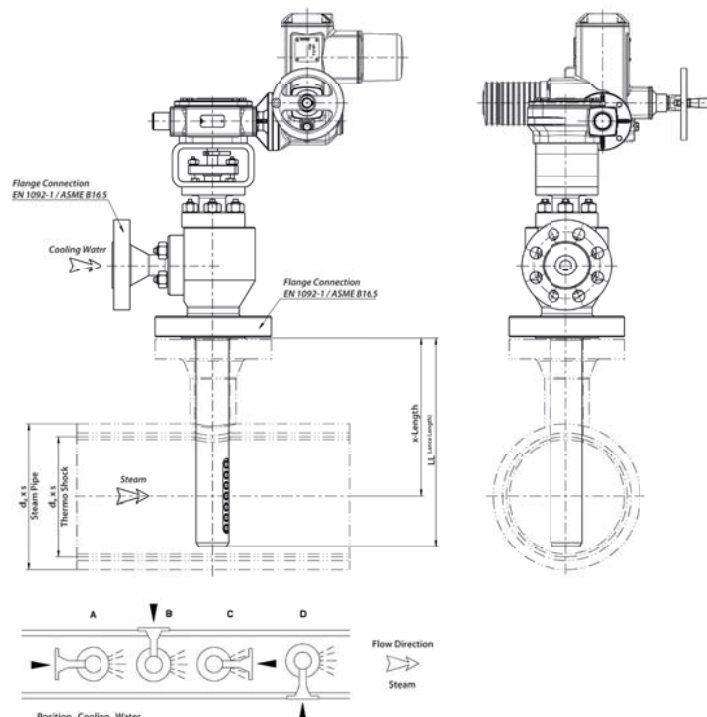

# ARCA Flow Group



## ARTES VALVE & SERVICE GmbH

[www.artes-valve.de](http://www.artes-valve.de)

- ▶ Control ball valves
- ▶ Desuperheaters
- ▶ Motive steam coolers
- ▶ Steam conversion stations
- ▶ Differential pressure transmitters
- ▶ Three-way valves

Parkallee 7

D-16727 Velten

Tel: +49 (0) 3304-24724-10

Fax: +49 (0) 3304-24724-99

E-Mail: [info@artes-valve.de](mailto:info@artes-valve.de)



## ARCA-Regler GmbH

[www.arca-valve.com](http://www.arca-valve.com)

- ▶ Valves
- ▶ Control valves
- ▶ Intelligent positioners
- ▶ Steam conversion valves
- ▶ Hygiene valves
- ▶ Pressure regulation units
- ▶ ECOTROL regulation valves



## WEKA AG

[www.weka-ag.ch](http://www.weka-ag.ch)

- ▶ Solenoid level indicators
- ▶ Tank content measuring systems
- ▶ Cryogenic components
- ▶ Inox valves



## von Rohr Armaturen AG

[www.von-rohr.ch](http://www.von-rohr.ch)

- ▶ Diaphragm valves
- ▶ Floor outlet valves
- ▶ Food-industry valves
- ▶ Sterile control valves
- ▶ Single-seat control valves
- ▶ Pneumatic lift actuators
- ▶ Corrosion-resistant control valves
- ▶ Electrical regulator actuators



## Feluwa Pumpen GmbH

[www.feluwa.com](http://www.feluwa.com)

- ▶ Hose diaphragm piston pumps
- ▶ MULTISAFE hose diaphragm piston pumps, for instance with metal diaphragm
- ▶ Sludge drainage facilities for mines
- ▶ Pump stations for pressure drainage
- ▶ Wastewater lifting facilities with cutter
- ▶ Separated sewage transfer facilities
- ▶ Homogenizing ducted-impeller pumps with cutter