

CENTER LINE
RS

alnab

brands you trust.

TECHNICAL DATASHEET
CENTER LINE® - Series RS Butterfly Valves
DIN/Metric



Energy Flow Solutions

www.craneenergy.com

Index

Model Numbers DN 40 - 1400	3
Model Numbers for Gear Operators	4
Possible Combinations	5
Material Selection DN 40 - 600	6-7
Dimension and Weights DN 40 - 600	8-9
Dimensions and Weights DN 700 - 1400	10-11
Gear Operators for Butterfly Valves DN 40 - 1200	12-13
Spare Parts - Replaceable Cartridge Seat Ring DN 40 - 1400	14
Spare Parts - Discs DN 40 - 1400	15-16
Spare Parts - Upper and Lower Stem DN 40 - 1400	17
Chemical Resistance of the Seat	18
Valve and Actuator Sizing	19
Actuator Sizing, Valve Torque and Installation	20
Bolting Dimensions DN 50 - 600	21

Model Numbers DN 40 - 1400

A	M	G	D	1	E	1	0	0	H
1	2	3	4	5	6	7	8	9	10

1. Series:
A = Series RS

2. Size:	
G = DN40	V = DN400
H = DN50	W = DN450
K = DN65	X = DN500
L = DN80	Y = DN600
M = DN100	Z = DN700
N = DN125	2 = DN800
P = DN150	3 = DN900
R = DN200	4 = DN1000
S = DN250	7 = DN1200
T = DN300	8 = DN1350
U = DN350	9 = DN1400

3. Disc Material and Shutoff Pressure:	
B = Stainless steel ⁵⁾	3,5 bar
G = Stainless steel	10 bar
S = Stainless steel	16 bar
C = Ductile iron, nickel-plated ^{2) 5)}	3,5 bar
H = Ductile iron, nickel-plated ²⁾	10 bar
T = Ductile iron, nickel-plated ²⁾	16 bar
K = ECTFE, coated	10 bar
P = Hostalen GUR® ³⁾	10 bar
N = Duplex	10 bar
M = Hastelloy®	10 bar

4. Pressure Class:					
Body Design	DN / PN	40-150	200-450	500-600	700-1400
Wafer body	PN 10	-	-	B	-
	PN 16	-	-	C	-
	PN 10/16	D	D	-	-
	ANSI 150*	N	N	N	-
Lug-type body	PN10	-	B	B	B
	PN16	-	C	C	C
	PN 10/16	D	-	-	-
	ANSI 150**	N	N	N	-
Flanged body	PN10	-	-	-	B

* DN 50-300 only GG.

** not DN 40.

1) further versions available on request.

2) not DN 40-150.

3) only DN 50-1200.

4) with centering lugs, not DN 40.

5) not DN 50-80.

5. Body Design / Material:
1 = Wafer body GGG40 DN 40-600
2 = Wafer body GG25 ^{*4)} DN 40-300
5 = Lug body GGG40
8 = Flanged body GGG40 DN 700-1200

6. Body Liner Material:
B = NBR (Buna-N)
C = HNBR
E = EPDM
F = EPDM-H with KTW drinking water approval
S = EPDM (Food Grade)
V = FPM (Viton®)

7. Shaft Material:
1 = Cr steel (standard)
2 = CrNi steel

8. + 9. Design ¹⁾:
00 = Standard
UD = Pressure and leak test P10/P12 according to EN 12266 as well as material certification for body approved according to EN 10204- 3.1
UG = Pressure and leak test P10/P12 according to EN 12266 as well as material certification for body approved according to EN 10204- 3.1 as well as separate head flange TAG3.

10. Actuation ¹⁾:
F = bare shaft
G = Gear operator with hand wheel
H = 10 pos. hand lever

Each Center Line® Butterfly Valve Series RS has a name plate with the model number stamped on. This number is complete to such an extent that it specifies each detail of the valve. It can be taken from the model numbering system above.

Ordering example:

Center Line® Butterfly Valve Series RS, DN 100, PN10/16, shutoff pressure of 10 bar, wafer body GGG40, shaft made of Cr steel, stainless steel disc, body liner EPDM, with 10 pos. hand lever.

Model Number: AMGD1E100H

Viton® is a registered trademark of DuPont Performance Elastomers L.L.C.
Hastelloy® is a registered trademark of Haynes International, Inc.

Model Numbers for Gear Operators

The model number of the gear operator is composed of a basic number and a specification number. The basic number is to be taken from the table below. The specification number is based on the following code:

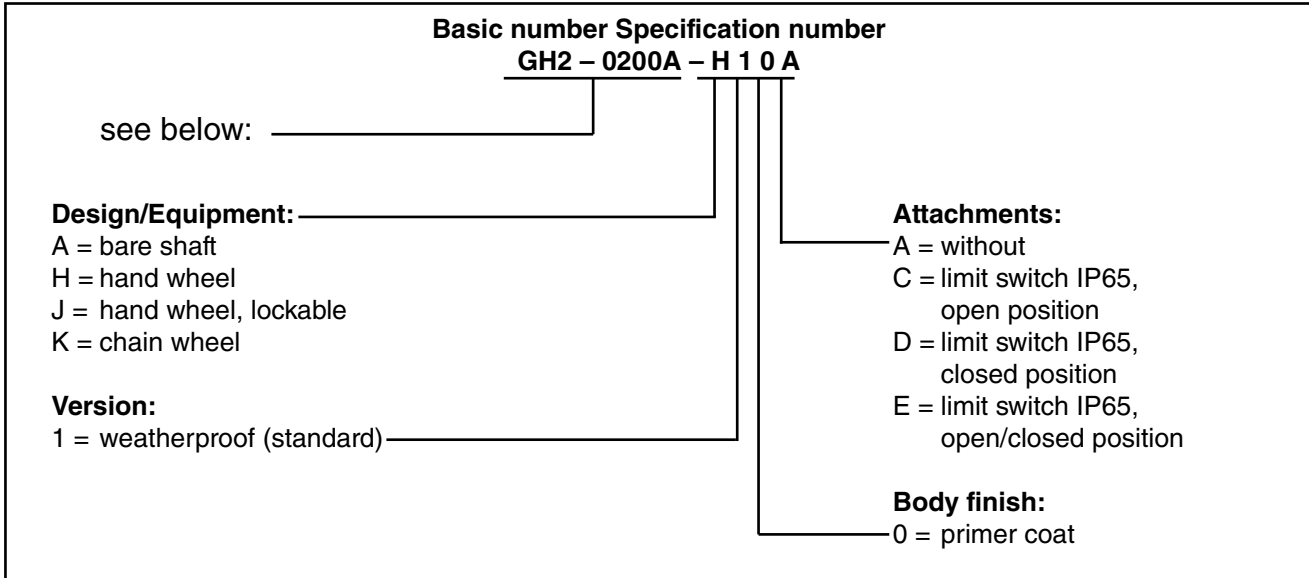

Basic Numbers for Gear Operators





Center Line® Valve Series RS		Gear Operator Basic Number	Center Line® Valve Series RS		Gear Operator Basic Number
DN	Shutoff Pressure		DN	Shutoff Pressure	
40-100	3,5, 10, 16 bar	GH2-0100A-	800	10, 3,5 bar	GH2-0800B- GH2-0800C-
125-200	3,5, 10, 16 bar	GH2-0200A-			
250-300	16, 3,5, 10 bar	GH2-0300A- GH2-0300B-	900	10, 3,5 bar	GH2-0900B- GH2-0900C-
350-400	3,5, 10, 16 bar	GH2-0500B-			
450-500	16, 3,5, 10 bar	GH2-0500A- GH2-0500B-	1000	3,5, 10 bar	GH2-1000A-
600	16, 3,5, 10 bar	GH2-0600A- GH2-0600B-	1200	3,5, 10 bar	GH2-1200B-
700	3,5, 10 bar	GH2-0700B-	1400	3,5, 10 bar	GH2-1400B-

Selection table hand lever/gear operator

The following table is a recommendation.

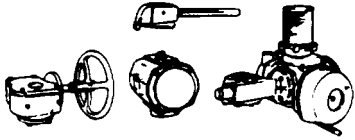
Shutoff Pressure	DN 40-125	DN 150	DN 200	DN 250	DN 300-1400
16 bar	Hand Lever	Hand Lever	Hand Lever	Gear Operator	Gear Operator
10 bar					
3,5 bar					

Possible Combinations

Component	Version	DN	Material
	Hand lever, 10 positions	40-200	-
	Hand lever, infinitely adjustable	40-200	-
	Gear operator	40-1400	-
	Pneumatic Revo® actuator	40-800	-
	Electric actuator	40-1400	-
Upper Stem 	-	40-1400	Chromium steel
		40-1400	Stainless steel
Cartridge Seat 	-	40-1400	NBR
		40-1200	HNBR
		40-1400	EPDM
		40-1200	FPM
		40-1200	EPDM-Food Grade
		40-1400	EPDM-H-Drinking Water
Disc 	-	200-600	Ductile iron, nickel-plated
		40-1400	Stainless steel
		40-600	GGG-ECTFE coated ¹⁾
		40-600	Hastelloy C® ^{1) 2)}
		700-1400	Hastelloy C® 22C ^{1) 2)}
		40-1400	Duplex ¹⁾
		50-1400	Hostalen GUR® lined ¹⁾
Lower stem 	-	40-1400	Chromium steel
		40-1400	Stainless steel

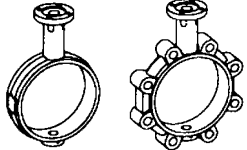
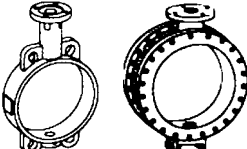
Body	Version	Material	DN 40-300	DN 350-600	DN 700-900	DN 1000-1400
	Wafer body	GGG 40	PN 10 PN 16	PN 10 PN 16		
	Lug body ³⁾	GGG 40	PN 10 PN 16	PN 10 PN 16		
	Wafer body with centering lugs	GG 25	PN 10 PN 16	-	-	-
	Flanged body	GGG 40	-	-	PN 10	PN 10

1) only for shutoff pressure of 10 bar.

2) or equivalent.

3) through hole thread

Material Selection DN 40 - 600

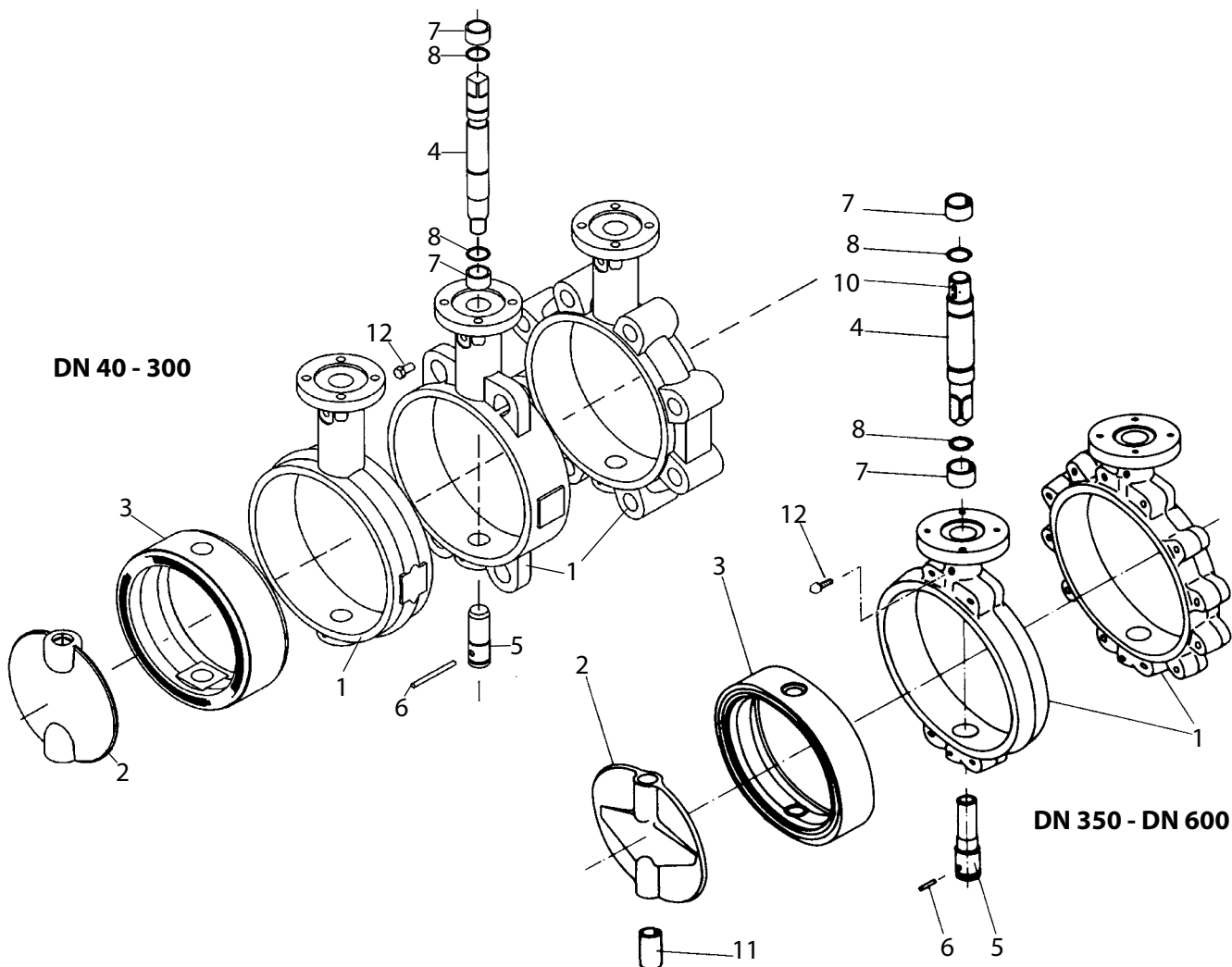

	Component	Material Specification	Material No.
Parts not in contact with the medium	Body (1)	EN-GJL-250 ¹⁾ EN-GJS-400-15 EN-GJS-400-18-LT	JL-1040 JS-1030 JS-1025
	Upper Stem (4) and Lower Stem (5)	Chromium steel X20Cr13 Stainless steel X5CrNiMo 18/10	1.4021 1.4401
	Roll pin (6)	Spring steel, galvanized	
	Bushing (7)	DU/ plastics ²⁾	
	Circlip (8)	Spring steel, galvanized	
	Key (10)	Steel	
	Bushing (11)	Bronze	
	Screw (12)	Galvanized steel	

1) only wafer body with centering lugs (DN 50-300).

2) according to the manufacturer's choice.

Material Selection DN 40 - 600

	Component	Material Specification	Material No.	Temperature Range
Parts in contact with the medium	Disc (2)	Ductile Iron, Nickel-Plated GGG-40-gal Ni ¹⁾	JS-1030	-10°C top temperature limited by Seat material
		ECTFE-coated		-10°C top temperature limited by Seat material
		Ductile Iron, Hostalen GUR® lined	UHMW-PE	-10°C to +70°C
		Stainless Steel, according to manufacturer's choice G-X5CrNiMo 19-11 G-X5CrNiMoNb 18/10	1,4408 1,4581	Limited by Seat material
		Duplex steel	J93404	Limited by Seat material
		Hastelloy®* according to manufacturing choice	2.4883 9.4602	Limited by Seat material
	Cartridge Seat (3)	EPDM (Ethylene-Propylene-Terpolymer)		-10°C to +120°C
		EPDM-H (Ethylene-Propylene-Terpolymer)		-10°C to +140°C with KTW-drinking water approval
		NBR (Perbunan®) (Copolymer of Acrylonitrile-Butadiene Rubber)		-10°C to +80°C up to 100°C with intermittent operation
		HNBR (Hydrogenated Acrylonitrile-Butadiene Rubber)		-10°C to +120°C
		FPM (Viton®)* (Copolymer of Vinyl Fluoride)		-10°C to +150°C
		EPDM (Food Grade)		-10°C to +120°C

* or equivalent.

1) only DN 200-600.

Perbunan® is a registered trademark of Bayer Corporation.

Dimension and Weights DN 40 - 600

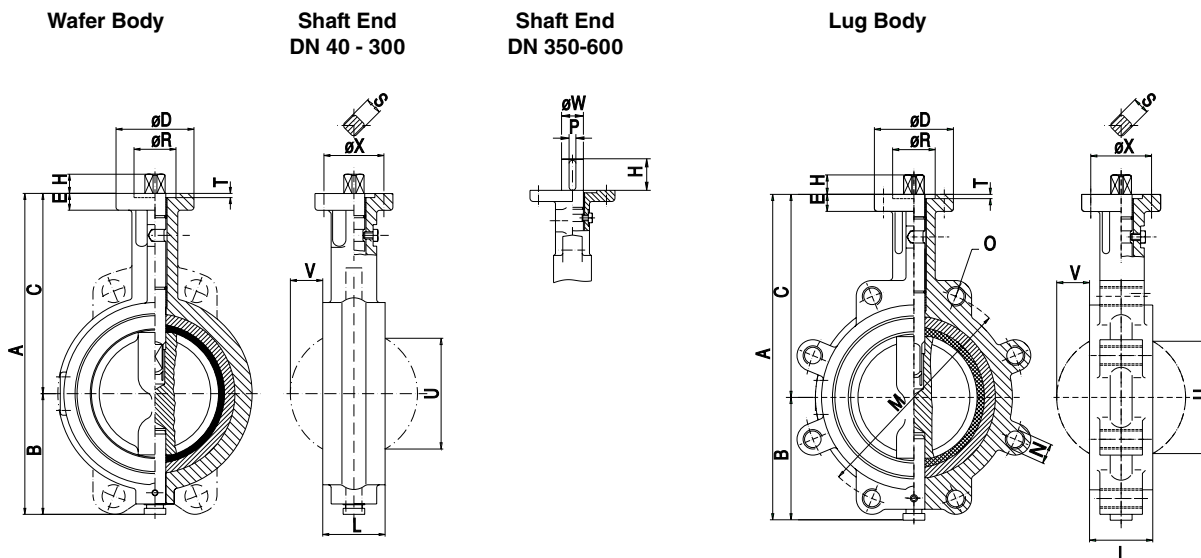

Dimensions in mm bare shaft

	Class	DN 40 ³⁾	DN 50	DN 65	DN 80	DN 100	DN 125	DN 150	DN 200	DN 250	DN 300	DN 350	DN 400	DN 450	DN 500	DN 600
A ¹⁾		202	202	225	240	268	292	320	386	462	542	627	677	743	793	934
A ²⁾		202	202	225	251	286	314	342	401	462	542	-	-	-	-	-
B		72	72	79	86	101	112	125	156	192	242	277	302	341	366	424
C ¹⁾		130	130	145	154	167	180	195	230	270	300	350	375	402	427	510
C ²⁾		130	130	145	165	185	202	217	245	270	300	-	-	-	-	-
D ⁴⁾		65	65	65	65	65	90	90	90	125	125	175	175	175	175	210
E ⁴⁾		14	14	14	14	14	15	15	15	18	18	23	23	23	23	25
H ⁴⁾		16	16	16	16	16	19	19	19	24	24	65	65	65	65	80
L ⁴⁾		43	43	45	45	52	56	56	60	68	78	78	102	114	127	154
M	PN 10	110	125	145	160	160	210	240	295	350	400	460	515	565	620	725
M	PN 16	110	125	145	160	180	210	240	295	355	410	470	525	585	650	770
M	ANSI 150	-	120,7	139,7	152,4	190,5	215,9	241,3	298,5	362	431,3	476,3	539,8	577,9	635	749,3
N	PN 10	M16	M16	M16	M16	M16	M16	M20	M20	M20	M20	M20	M24	M24	M24	M27
N	PN 16	M16	M16	M16	M16	M16	M16	M20	M20	M24	M24	M24	M27	M27	M30	M33
N	ANSI 150	-	5/8 - 11	5/8 - 11	5/8 - 11	5/8 - 11	3/4 - 10	3/4 - 10	3/4 - 10	7/8 - 9	7/8 - 9	1 - 8	1 - 8	1 1/8 - 8	1 1/8 - 8	1 1/4 - 8
O	PN 10	-	4	4	8	8	8	8	8	12	12	16	16	20	20	20
O	PN 16	4	4	4	8	8	8	8	12	12	12	16	16	20	20	20
O	ANSI 150	-	4	4	4	8	8	8	12	12	12	16	16	20	20	20
P		-	-	-	-	-	-	-	-	-	-	14	14	14	14	20
R		Ø35	Ø35	Ø35	Ø35	Ø35	Ø55	Ø55	Ø55	Ø70	Ø70	Ø100	Ø100	Ø100	Ø100	Ø130
S ⁴⁾		14-0,1	14-0,1	14-0,1	14-0,1	14-0,1	17-0,1	17-0,1	17-0,1	22-0,1	22-0,1	-	-	-	-	-
T		3,5	3,5	3,5	3,5	3,5	3,5	3,5	3,5	3,5	3,5	5	5	5	5	7
U		39	39	56	71	93	117	144	191	240	291	327	371	423	472	575
V		7	7	13	19	27	37	49	70	90	111	129	141	162	181	221
W		-	-	-	-	-	-	-	-	-	-	Ø45	Ø45	Ø45	Ø45	Ø70
X		Ø50/4 x Ø7 F05					Ø70/4 x Ø9 F07			Ø102/4 x Ø11 F10		Ø140/4 x Ø18 F14			Ø165/4 x Ø22 F16	

1) Body made of Ductile Iron.

2) Body made of Cast iron.

3) Inner parts DN 50.

4) Dimensions in accordance with DIN/ISO.

Weights in kg

Bare Shaft Valve	DN 40	DN 50	DN 65	DN 80	DN 100	DN 125	DN 150	DN 200	DN 250	DN 300	DN 350	DN 400	DN 450	DN 500	DN 600
Wafer body*	2,2	2,2	2,8	3,4	4,7	6,8	7,6	11,5	19,6	31,2	50	72	92	111	195
Lug body	3,4	3,4	4,0	4,8	6,9	10,6	11,4	15,9	26,0	38,2	60	92	108	151	245

*Version with centering lugs made of Cast Iron up to DN 300.

Dimensions and Weights DN 40 - 600

Valve with Hand Lever

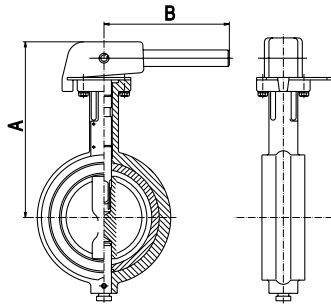

Valve with Gear Operator

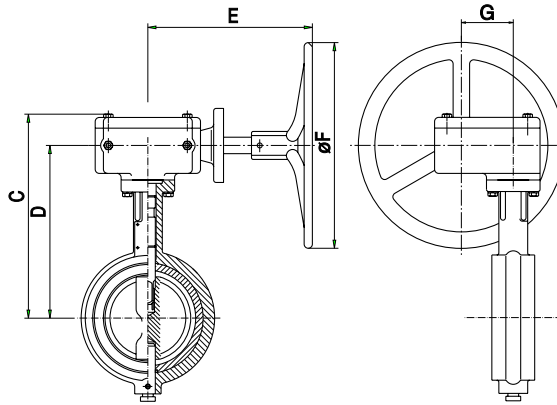

Valve with Revo® Actuator

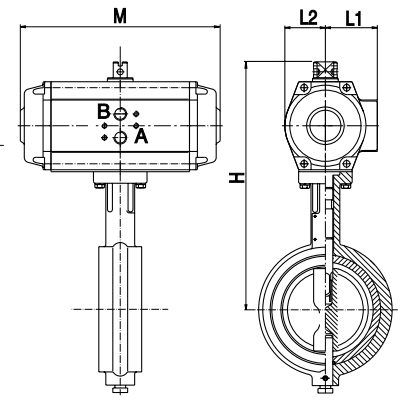

Dimensions in mm* with actuation

	DN 40	DN 50	DN 65	DN 80	DN 100	DN 125	DN 150	DN 200	DN 250	DN 300	DN 350	DN 400	DN 450	DN 500	DN 600
A ¹⁾	181	181	197	205	218	231	246	281	-	-	-	-	-	-	-
A ²⁾	181	181	197	216	236	253	268	296	-	-	-	-	-	-	-
B	200	200	200	200	200	255	255	255	-	-	-	-	-	-	-
C ¹⁾	206	206	222	230	243	256	271	306	346	376	437	462	489	514	616
C ²⁾	206	206	222	241	261	278	293	321	346	376	-	-	-	-	-
D ¹⁾	172	172	188	196	209	222	237	272	312	342	402	427	454	479	560
D ²⁾	172	172	188	207	227	244	259	287	312	342	-	-	-	-	-
E	230	230	230	230	230	230	230	230	230	230	285	285	285	285	366
F	200	200	200	200	200	250	250	250	250	250	400	400	400	400	610
G	65	65	65	65	65	65	65	65	65	65	96	96	96	96	123
H ¹⁾	216	216	232	266,5	308	321	361	396	456	486	652	677	704	729	962
H ²⁾	216	216	232	277,5	326	343	383	411	456	486	-	-	-	-	-
L1	38	38	38	52,5	67	67	79	79	94	94	135	135	135	135	211
L2	33	33	33	41	55	55	67	67	78	78	119	119	119	119	211
M	175	175	175	205	214	214	267	267	355	355	388	388	510	510	533

* Dimensions apply to valves PN 10/16 Δ p 10 bar, Revo® actuator, double-acting at 5 bar air supply.

1) Body made of Ductile Iron.

2) Body made of Cast Iron.

Weights in kg**

Valve with	DN 40	DN 50	DN 65	DN 80	DN 100	DN 125	DN 150	DN 200	DN 250	DN 300	DN 350	DN 400	DN 450	DN 500	DN 600
Hand lever	3,8	3,8	4,4	14,6	5,9	18,5	9,5	13,6	-	-	-	-	-	-	-
Gear Op,	10,2	10,2	10,8	11,0	12,3	14,8	15,8	19,9	27,6	39,0	66,8	88,8	108,8	127,8	230
Revo®	4,3	4,3	4,9	5,6	8,1	10,6	11,4	19,4	31,2	43,2	76,0	104	129	148	318

** Weights apply to valves with wafer body.

Dimensions and Weights DN 700 - 1400

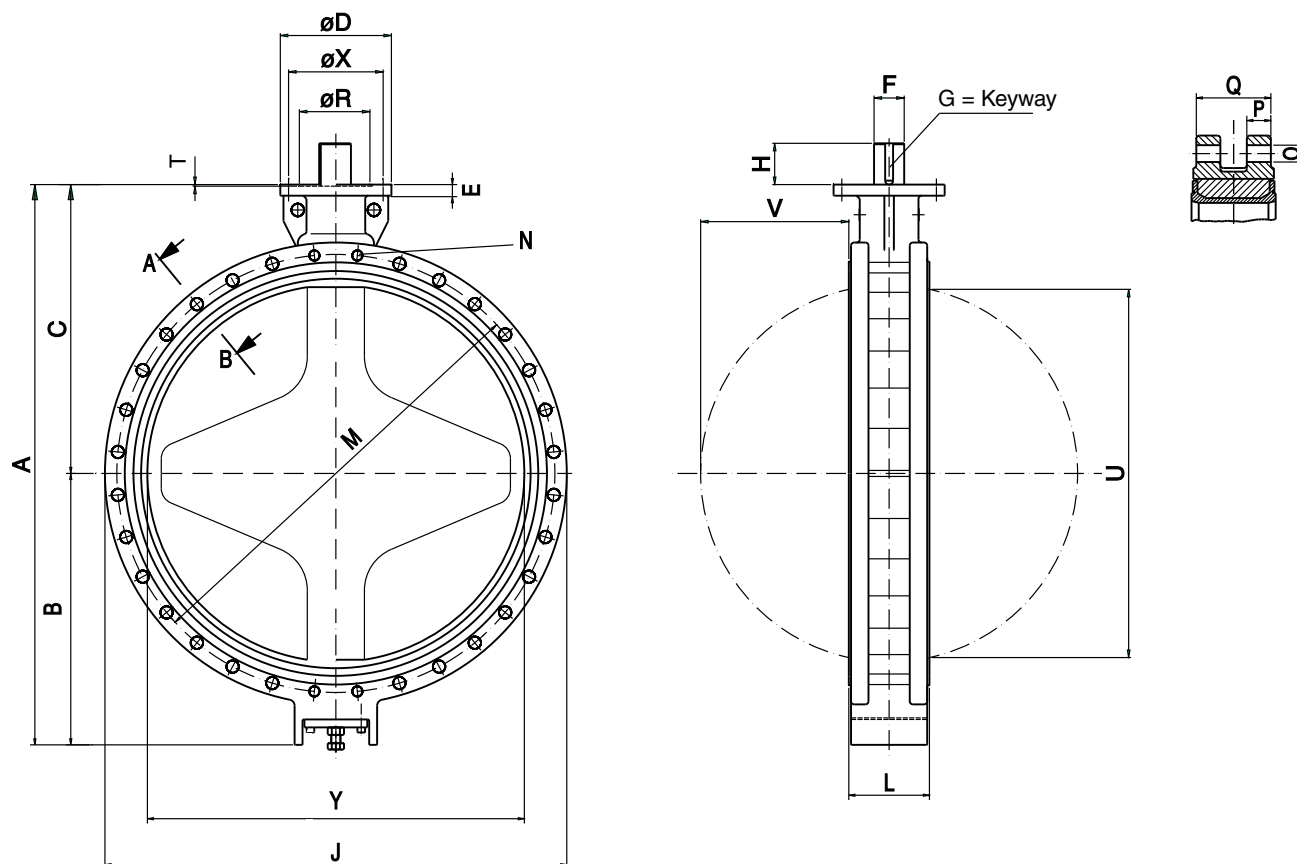

Dimensions in mm bare shaft end

Measurement	Class	DN 700	DN 800	DN 900	DN 1000	DN 1200	DN 1400
A		1065	1200	1330	1540	1765	2061
B		515	580	640	750	855	1025
C		550	620	690	790	910	1036
D ²⁾		Ø300	Ø300	Ø300	Ø350	Ø350	Ø415
E		25	25	25	35	35	40
F		Ø70	Ø75	Ø85	Ø90	Ø95	Ø100
G		20 x 115	20 x 115	22 x 115	25 x 130	25 x 130	28 x 180
H		110	110	110	130	130	180
J	PN 10	910	1025	1125	1230	1455	1675
L ²⁾		165	190	203	216	254	279
M	PN10	Ø840	Ø950	Ø1050	Ø1160	Ø1380	Ø1590
N	PN10	2x4xM27x35 deep	2x4xM30x43 deep	2x4xM30x43 deep	2x4xM33x48 deep	2x4xM36x48 deep	4x4xM39x50 deep
O ¹⁾	PN10	2x20xØ30	2x20xØ33	2x24xØ33	2x24xØ36	2x28xØ39	2x28xØ42
R ²⁾		Ø200	Ø200	Ø200	Ø230	Ø230	Ø260
T		5	5	5	5	5	5
U		669	766	865	965	1160	1348
V		262	300	343	387	467	549
X		Ø254/8xØ17.5 (F25)	Ø254/8xØ17.5 (F25)	Ø254/8xØ17.5 (F25)	Ø298/8xØ22 (F30)	Ø298/8xØ22 (F30)	Ø356/8xØ33 (F35)
Y		686	786	885	986	1186	1376
P		45	50	50	50	55	65
Q		155	180	190	206	244	269

1) Flanged body.

2) Dimensions in accordance with DIN/ISO.

Dimensions and Weights **DN 700 - 1400**

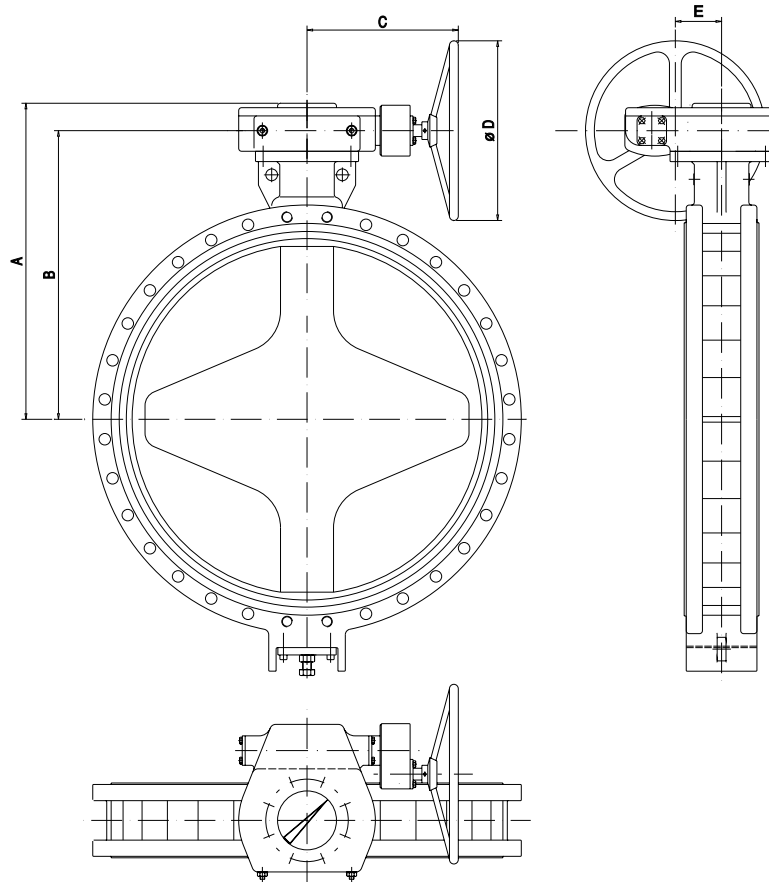

Dimensions mm (valve with gear operator*)

Measurement	DN 700	DN 800	DN 900	DN 1000	DN 1200	DN 1400
A	678	748	849	954	1074	N/A
B	616	686	754	860	980	N/A
C	497	497	529	551	551	N/A
D	610	610	610	610	610	N/A
E	138	138	181	237	237	N/A

* for valves Δp 10 bar.
For N/A please consult factory.

Weights in kg

Measurement	DN 700	DN 800	DN 900	DN 1000	DN 1200	DN 1400
flanged body bare shaft	450	550	700	900	1350	N/A
flanged body with gear op.	515	615	808	1069	1519	N/A

For N/A please consult factory.

Gear Operators for Butterfly Valves DN 40 - 1200

Model Numbers and Weights

Valve		Gear Operator with Hand Wheel		Gear Operator with Lockable Hand Wheel		Gear Operator with Chainwheel	
DN	Shutoff Pressure Bar	Model	Weight Kg	Model	Weight Kg	Model	Weight Kg
40-100	3,5-16	GH2-0100A-H10A	7,8	GH2-0100A-J10A	8,0	GH2-0100A-K10A	7,7
125-200	3,5-16	GH2-0200A-H10A	8,0	GH2-0200A-J10A	8,2	GH2-0200A-K10A	7,7
250-300	3,5-10	GH2-0300B-H10A	10,8	GH2-0300B-J10A	10,4	GH2-0300B-K10A	7,7
250-300	16	GH2-0300A-H10A	19,6	GH2-0300A-J10A	19,8	GH2-0300A-K10A	16,6
350-400	3,5-16	GH2-0500B-H10A	16,8	GH2-0500B-J10A	17,4	GH2-0500B-K10A	21,2
450-500	3,5-10	GH2-0500B-H10A	16,8	GH2-0100B-J10A	17,4	GH2-0500B-K10A	21,2

Article number for chain: 6104010. When ordering specify length.

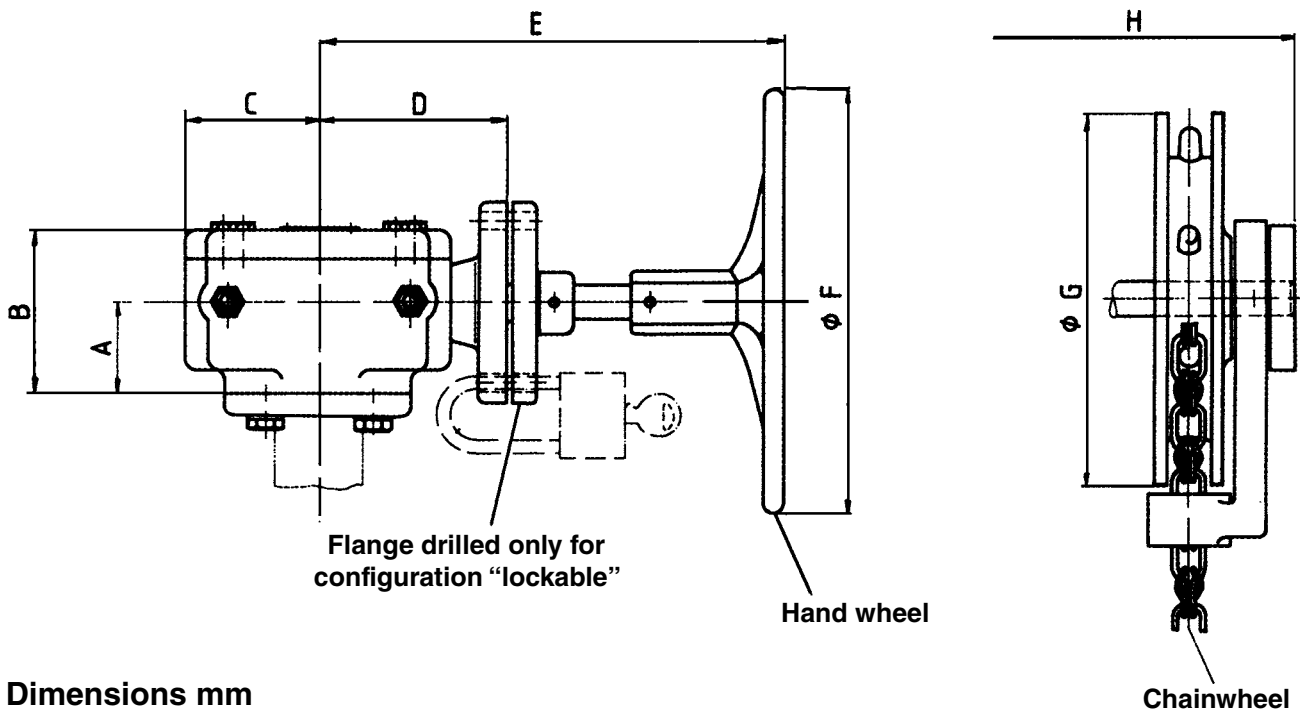

Dimensions mm

Gear Operator Model	Hand Wheel turns for 90°	A	B	C	D	E	F	G	H	K	L	M
GH2-0100A	10	42	76	64	92	230	200	265	184	184	65	45
GH2-0200A	10	42	76	64	92	230	250	265	184	184	65	45
GH2-0300B	10	42	76	64	92	230	250	265	184	184	65	45
GH2-0300A	19	52	87	100	134	282	400	365	212	242	96	64
GH2-0500B	19	52	87	100	134	282	400	365	212	242	96	64

Gear Operators for Butterfly Valves DN 40 - 1200

Model Numbers and Weights

Valve		Gear Operator with Hand Wheel		Valve		Gear Operator with Hand Wheel	
DN	Shutoff Pressure Bar	Model	Weight Kg	DN	Shutoff Pressure Bar	Model	Weight Kg
450/500	16	GH2-0500A-H10A	32	900	3.5	GH2-0900C-H10A	65
600	3,5-10	GH2-0600B-H10A	32		10	GH2-0900B-H10A	108
	16	GH2-0600A-H10A	65	1000	3,5-10	GH2-1000A-H10A	169
700	3,5-10	GH2-0700B-H10A	65	1200	3,5-10	GH2-1200B-H10A	169
800	3.5	GH2-0800C-H10A	65				
	10	GH2-0800B-H10A	65				

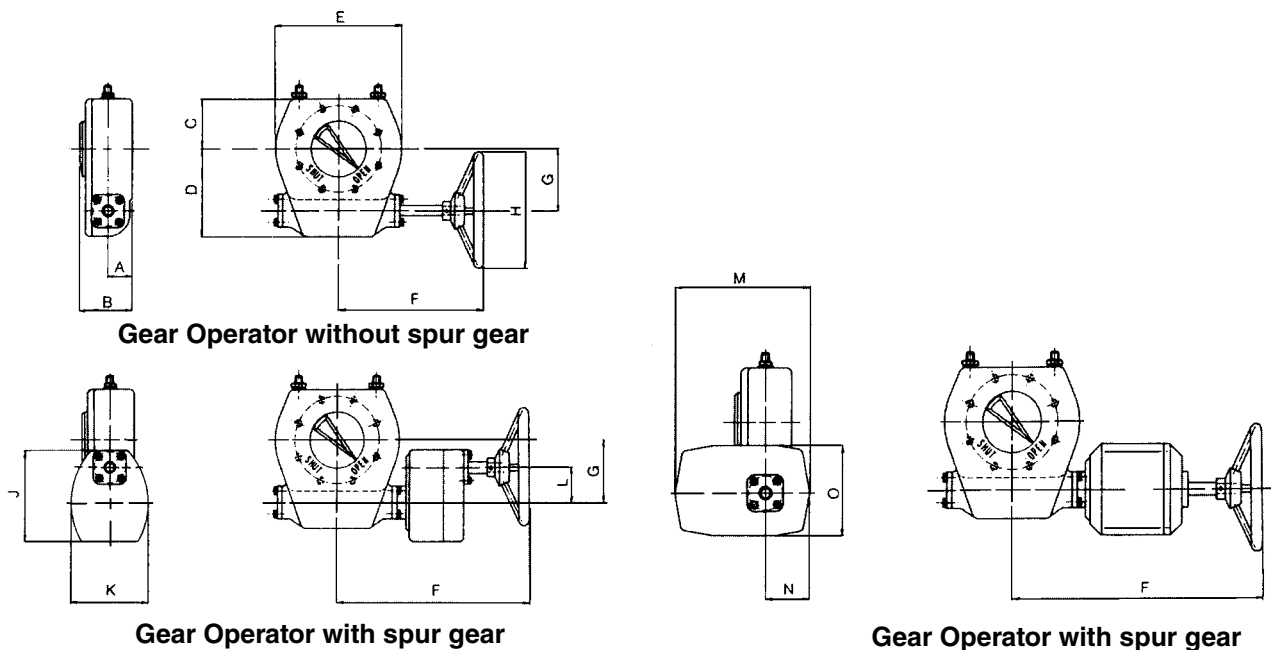

Dimensions mm

Gear Operator Model	Hand Wheel turns for 90°	A	B	C	D	E	F	G	H	J	K	L	M	N	O
GH2-0500A/0600B	17	50	106	114	178	252	366	123	610	-	-	-	-	-	-
GH2-0600A	43	66	128	155	195	310	497	138	610	210	171	78	-	-	-
GH2-0700B	43	66	128	155	195	310	497	138	610	210	171	78	-	-	-
GH2-0800C	43	66	128	175	195	310	497	138	610	210	171	78	-	-	-
GH2-0800B	45	66	128	155	195	310	497	138	610	210	171	84	-	-	-
GH2-0900C	45	66	128	155	195	310	497	138	610	210	171	84	-	-	-
GH2-0900B	63	63,5	159	140	251	356	529	181	610	210	171	84	-	-	-
GH2-1000A	75	70	164	175	326	463	551	237	610	210	171	84	-	-	-
GH2-1200B	75	70	164	175	326	463	551	237	610	210	171	84	-	-	-

Spare Parts - Replaceable Cartridge Seat Ring DN 40 - 1400

	EPDM	EPDM-H	EPDM-H	EPDM - Food Grade	NBR
Remarks:		With KTW Drinking Water Certification	With Alufree Backup Ring	Only For FDA Required	DIN-DVGW Gas
Temperature Range:	-10°C To +120°C	-10°C To +140°C	-10°C To +140°C	-10°C To +140°C	-10°C To +80°C
DN					
40	KS1A0050-9E-000B	KS1A0050-9L-0000	KS1A0050-9L-0000	KS1A0050-9D-0000	KS1A0050-9N-0000
50	KS1A0050-9E-000B	KS1A0050-9L-0000	KS1A0050-9L-0000	KS1A0050-9D-0000	KS1A0050-9N-0000
65	KS1A0065-9E-000B	KS1A0065-9L-0000	KS1A0065-9L-0000	KS1A0065-9D-0000	KS1A0065-9N-0000
80	KS1A0080-9E-000B	KS1A0080-9L-0000	KS1A0080-9L-0000	KS1A0080-9D-0000	KS1A0080-9N-0000
100	KS1A0100-9E-000B	KS1A0100-9L-0000	KS1A0100-9L-0000	KS1A0100-9D-0000	KS1A0100-9N-0000
125	KS1A0125-9E-000B	KS1A0125-9L-0000	KS1A0125-9L-0000	KS1A0125-9D-0000	KS1A0125-9N-0000
150	KS1A0150-9E-000B	KS1A0150-9L-0000	KS1A0150-9L-0000	KS1A0150-9D-0000	KS1A0150-9N-0000
200	KS1A0200-9E-000B	KS1A0200-9L-0000	KS1A0200-9L-0000	KS1A0200-9D-0000	KS1A0200-9N-0000
250	KS1A0250-9E-000B	KS1A0250-9L-0000	KS1A0250-9L-0000	KS1A0250-9D-0000	KS1A0250-9N-0000
300	KS1A0300-7E-000A	KS1A0300-8L-0000	KS1A0300-GL-0M00	KS1A0300-GD-0M00	KS1A0300-8N-0000
350	use EPDM-H part #	KS1A0350-8L-0000	KS1A0350-GL-0M00	KS1A0350-GD-0M00	KS1A0350-8N-0000
400	use EPDM-H part #	KS1A0400-8L-0000	KS1A0400-GL-0M00	KS1A0400-GD-0M00	KS1A0400-8N-0000
450	use EPDM-H part #	KS1A0450-8L-0000	KS1A0450-7L-0000	KS1A0450-GD-0M00	KS1A0450-8N-0000
500	use EPDM-H part #	KS1A0500-8L-0000	KS1A0500-GL-0M00	KS1A0500-GD-0M00	KS1A0500-8N-0000
600	use EPDM-H part #	KS1A0600-8L-0000	KS1A0600-GL-0M00	KS1A0600-GD-0M00	KS1A0600-8N-0000
700	use EPDM-H part #	KS1A0700-7L-0000	KS1A0700-7L-0000	KS1A0700-7D-0000	KS1A0700-7N-0000
800	use EPDM-H part #	KS1A0800-7L-0000	KS1A0800-7L-0000	KS1A0800-7D-0000	KS1A0800-7N-0000
900	use EPDM-H part #	KS1A0900-7L-0000	KS1A0900-7L-0000	KS1A0900-7D-0000	KS1A0900-7N-0000
1000	use EPDM-H part #	KS1A1000-7L-0000	KS1A1000-7L-0000	KS1A1000-7D-0000	KS1A1000-7N-0000
1200	use EPDM-H part #	KS1A1200-7L-0000	KS1A1200-7L-0000	KS1A1200-7D-0000	KS1A1200-7N-0000
1400	Consult factory	Consult factory	Consult factory	N/A	Consult factory

	HNBR	FPM (Viton®)	FPM (Viton®) 0677	FPM - Food Grade (Viton®)
Remarks:				Only For FDA Required
Temperature Range:	-10°C to +120°C	-10°C to +150°C	-10°C to +150°C	-10°C to +150°C
DN				
40	KS1A0050-9H-0000	KS1A0050-9F-0000	KS1A0050-9P-0000	KS1A0050-8K-0000
50	KS1A0050-9H-0000	KS1A0050-9F-0000	KS1A0050-9P-0000	KS1A0050-8K-0000
65	KS1A0065-9H-0000	KS1A0065-9F-0000	KS1A0065-9P-0000	KS1A0065-8K-0000
80	KS1A0080-9H-0000	KS1A0080-9F-0000	KS1A0080-9P-0000	KS1A0080-8K-0000
100	KS1A0100-9H-0000	KS1A0100-9F-0000	KS1A0100-9P-0000	KS1A0100-8K-0000
125	KS1A0125-9H-0000	KS1A0125-9F-0000	KS1A0125-9P-0000	N/A
150	KS1A0150-9H-0000	KS1A0150-9F-0000	KS1A0150-9P-0000	N/A
200	KS1A0200-9H-0000	KS1A0200-9F-0000	N/A	N/A
250	KS1A0250-9H-0000	KS1A0250-9F-0000	N/A	N/A
300	KS1A0300-8H-0000	KS1A0300-8F-0000	N/A	N/A
350	KS1A0350-8H-0000	KS1A0350-8F-0000	N/A	N/A
400	KS1A0400-8H-0000	KS1A0400-8F-0000	N/A	N/A
450	KS1A0450-8H-0000	KS1A0450-8F-0000	N/A	N/A
500	KS1A0500-8H-0000	KS1A0500-8F-0000	N/A	N/A
600	KS1A0600-8H-0000	KS1A0600-8F-0000	N/A	N/A
700	KS1A0700-7H-0000	KS1A0700-7F-0000	N/A	N/A
800	KS1A0800-7H-0000	KS1A0800-7F-0000	N/A	N/A
900	KS1A0900-7H-0000	KS1A0900-7F-0000	N/A	N/A
1000	KS1A1000-7H-0000	KS1A1000-7F-0000	N/A	N/A
1200	KS1A1200-7H-0000	KS1A1200-7F-0000	N/A	N/A
1400	N/A	N/A	N/A	N/A

Please note: Material of backup ring apply to manufacturing standard.

Spare Parts - Discs DN 40 - 1400

DN	Shutoff Pressure bar	GGG ni. pltd.	Stainless Steel	Hastelloy®	Duplex	ECTFE coated	Hostalen GUR® lined
50	16		KD1B0050 3HP000				
	10		KD1B0050 3HN000	KD1B0050 4AN000	KD1B0050 4SN000	KD1B0050 3HS03E	KD1B0050 3HNB3B
	3,5		KD1B0050 3HM000				
65	16		KD1B0065 3HP000				
	10		KD1B0065 3HN000	KD1B0065 4AN000	KD1B0065 4SN000	KD1B0065 3HS03E	KD1B0065 3HNB3B
	3,5		KD1B0065 3HM000				
80	16		KD1B0080 3HP000				
	10		KD1B0080 3HN000	KD1B0080 4AN000	KD1B0080 4SN000	KD1B0080 3HS03E	KD1B0080 3HNB3B
	3,5		KD1B0080 3HM000				
100	16		KD1B0100 3HP000				
	10		KD1B0100 3HN000	KD1B0100 4AN000	KD1B0100 4SN000	KD1B0100 3HS03E	KD1B0100 3HNB3B
	3,5		KD1B0100 3HM000				
125	16		KD1B0125 3HP000				
	10		KD1B0125 3HN000	KD1B0125 4AN000	KD1B0125 4SN000	KD1B0125 3HS03E	KD1B0125 3HNB3B
	3,5		KD1B0125 3HM000				
150	16		KD1B0150 3HP000				
	10		KD1B0150 3HN000	KD1B0150 4AN000	KD1B0150 4SN000	KD1B0150 3HS03E	KD1B0150 3HNB3B
	3,5		KD1B0150 3HM000				
200	16	KD1A0200 1BP03N	KD1A0200 3AP000				
	10	KD1A0200 1BN03N	KD1A0200 3AN000	KD1A0200 4AN000	KD1A0200 4SN000	KD1A0200 1BS03E	KD1A0200 1BNB3B
	3,5	KD1A0200 1BM03N	KD1A0200 3AM000				
250	16	KD1A0250 1BP03N	KD1A0250 3AP000				
	10	KD1A0250 1BN03N	KD1A0250 3AN000	KD1A0250 4AN000	KD1A0250 4SN000	KD1A0250 1BS03E	KD1A0250 1BNB3B
	3,5	KD1A0250 1BM03N	KD1A0250 3AM000				
300	16	KD1A0300 1BP03N	KD1A0300 3AP000				
	10	KD1A0300 1BN03N	KD1A0300 3AN000	KD1A0300 4AN000	KD1A0300 4SN000	KD1A0300 1BS03E	KD1A0300 1BNB3B
	3,5	KD1A0300 1BM03N	KD1A0300 3AM000				

Spare Parts - Discs DN 40 - 1400

DN	Shutoff Pressure Bar	Nickel Plated	Stainless Steel	Hastelloy®	Duplex	ECTFE Coated	Hostalen GUR® Lined
350	16	KD1A0350 1BP03N	KD1A0350 3AP000				
	10	KD1A0350 1BN03N	KD1A0350 3AN000	KD1A0350 4AN000	KD1A0350 4SN000	KD1A0350 1BS03E	KD1A02350 1BNB3B
	3,5	KD1A0350 1BM03N	KD1A0350 3AM000				
400	16	KD1A0400 1BP03N	KD1A0400 3AP000				
	10	KD1A0400 1BN03N	KD1A0400 3AN000	KD1A0400 4AN000	KD1A0400 4SN000	KD1A0400 1BS03E	KD1A0400 1BNB3B
	3,5	KD1A0400 1BM03N	KD1A0400 3AM000				
450	16	KD1A0450 1BP03N	KD1A0450 3AP000				
	10	KD1A0450 1BN03N	KD1A0450 3AN000	KD1A0450 4AN000	KD1A0450 4SN000	KD1A0450 1BS03E	KD1A0450 1BNB3B
	3,5	KD1A0450 1BM03N	KD1A0450 3AM000				
500	16	KD1A0500 1BP03N	KD1A0500 3AP000				
	10	KD1A0500 1BN03N	KD1A0500 3AN000	KD1A0500 4AN000	KD1A0500 4SN000	KD1A0500 1BS03E	KD1A0500 1BNB3B
	3,5	KD1A0500 1BM03N	KD1A0500 3AM000				
600	16	KD1A0600 1BP03N	KD1A0600 3AP000				
	10	KD1A0600 1BN03N	KD1A0600 3AN000	KD1A0600 4AN000	KD1A0600 4SN000	KD1A0600 1BS03E	KD1A0600 1BNB3B
	3,5	KD1A0600 1BM03N	KD1A0600 3AM000				
700	10		KD1A0700 3AN000	KD1A0700 4HN000	KD1A0700 4SN000		KD1A0700 1BNB3B
800	10		KD1A0800 3AN000	KD1A0800 4HN000	KD1A0800 4SN000		KD1A0800 1BNB3B
900	10		KD1A0900 3AN000	KD1A0900 4HN000	KD1A0900 4SN000		KD1A0900 1BNB3B
1000	10		KD1A1000 3AN000	KD1A1000 4HN000	KD1A1000 4SN000		KD1A1000 1BNB3B
1200	10		KD1A1200 3AN000	KD1A1200 4HN000	KD1A1200 4SN000		KD1A1200 1BNB3B
1400	10		KD1A1400 3AN000	KD1A1400 4HN000	KD1A1400 4SN000		KD1A1400 1BNB3B

Spare Parts - Upper and Lower Stem DN 40 - 1400

DN	Part					
	Upper Stem for	Upper Stem for	Upper Stem for	Upper Stem for	Lower Stem for	Lower Stem for
	Body Material					
	Ci Body	Ci Body	Di Body	Di Body	Di & Ci Body	Di & Ci Body
	Stem Material					
1.4021 (Std.)	1.4401	1.4021 (Std.)	1.4401	1.4021 (Std.)	1.4401	
40	KW1B0050 6A0000	KW1B0050 6B0000	KW1B0050 6A0000	KW1B0050 6B0000	KW2A0050 6A0000	KW2A0050 6B0000
50	KW1B0050 6A0000	KW1B0050 6B0000	KW1B0050 6A0000	KW1B0050 6B0000	KW2A0050 6A0000	KW2A0050 6B0000
65	KW1B0065 6A0000	KW1B0065 6B0000	KW1B0065 6A0000	KW1B0065 6B0000	KW2A0065 6A0000	KW2A0065 6B0000
80	KW5B0080 6A0000	KW5B0080 6B0000	KW1B0065 6A0000	KW1B0065 6B0000	KW2A0065 6A0000	KW2A0065 6B0000
100	KW5B0100 6A0000	KW5B0100 6B0000	KW1B0100 6A0000	KW1B0100 6B0000	KW2A0100 6A0000	KW2A0100 6B0000
125	KW5B0125 6A0000	KW5B0125 6B0000	KW1B0125 6A0000	KW1B0125 6B0000	KW2A0125 6A0000	KW2A0125 6B0000
150	KW5B0125 6A0000	KW5B0125 6B0000	KW1B0125 6A0000	KW1B0125 6B0000	KW2A0125 6A0000	KW2A0125 6B0000
200	KW5A0200 6A0000	KW5A0200 6B0000	KW1A0200 6A0000	KW1A0200 6B0000	KW2A0200 6A0000	KW2A0200 6B0000
250	KW1A0250 6A0000	KW1A0250 6B0000	KW1A0250 6A0000	KW1A0250 6B0000	KW2A0250 6A0000	KW2A0250 6B0000
300	KW1A0300 6A0000	KW1A0300 6B0000	KW1A0300 6A0000	KW1A0300 6B0000	KW2A0300 6A0000	KW2A0300 6B0000
350			KW1A0350 6A0000	KW1A0350 6B0000	KW2A0350 6A0000	KW2A0350 6B0000
400			KW1A0350 6A0000	KW1A0350 6B0000	KW2A0350 6A0000	KW2A0350 6B0000
450			KW1A0450 6A0000	KW1A0450 6B0000	KW2A0450 6A0000	KW2A0450 6B0000
500			KW1A0450 6A0000	KW1A0450 6B0000	KW2A0450 6A0000	KW2A0450 6B0000
600			KW1A0600 6A0000	KW1A0600 6B0000	KW2A0600 6A0000	KW2A0600 6B0000
700			KW1A0700 6A0000	KW1A0700 6B0000	KW2A0700 6A0000	KW2A0700 6B0000
800			KW1A0800 6A0000	KW1A0800 6B0000	KW2A0800 6A0000	KW2A0800 6B0000
900			KW1A0900 6A0000	KW1A0900 6B0000	KW2A0900 6A0000	KW2A0900 6B0000
1000			KW1A1000 6A0000	KW1A1000 6B0000	KW2A1000 6A0000	KW2A1000 6B0000
1200			KW1A1200 6A0000	KW1A1200 6B0000	KW2A1200 6A0000	KW2A1200 6B0000
1400			KW1A1400 6A0000	KW1A1400 6B0000	KW2A1400 6A0000	KW2A1400 6B0000

Chemical Resistance of the Seat

The following Seat Material/Fluid combinations are based on practical experience. The materials quoted may not be suitable for all line media over the entire temperature range. Chemical resistance of the seat can be affected by fluid concentration, temperature, pressure,

flow rate and ventilation. Therefore the suitability of any seat material/fluid combination cannot be guaranteed. If in doubt, the suitability should be checked by testing under the required operating conditions.

Valve Seat Material	Resistant Against	Temperature Range
NBR (Perbunan®) Acrylonitrile Butadiene Rubber	Petroleum, grease, alcohol, glycol, propane, butane, diesel fuels, compressed air, latex and many other media.	-10°C to +80°C or up to +100°C for intermittent operation
HNBR (Therban®) Hydrogenated Acrylonitrile Butadiene Rubber	Petroleum, grease, alcohol, glycol, propane, butane, diesel fuels, alkalis, salts, amines, ammonia, many other media. Highly polluted media with high velocity, abrasive media.	-10°C up to +120°C
EPDM Ethylene Propylene Terpolymer	Ozone, phosphate, ester, ketones, alcohols, glycols, dilute-sulphuric acid, alkaline solutions in general, treated water (with caustic soda, sodium sulphite, chlorine), hot water and steam (it is attacked by hydrocarbonaceous solutions and oils, chlorinated hydrocarbons, turpentine and all other petroleum based oils).	-10°C up to +120°C
EPDM-H	As EPDM including drinking water approval (KTW/DVGW).	-10°C up to +140°C
FPM (Viton®) Fluorelastomer	Strong and weak mineral acids, aliphatic hydrocarbons, aromatic phenolic and halogenated hydrocarbons, ester of aromatic acids, aliphatic acids, phosphoric acids, phosphoric ester, aromatic ethers, aliphatic ethers, ozone, chlorine and hypochlorite. (Viton® is not suitable for dry heat, hot water and steam).	-10°C up to +150°C

Therban® is a registered trademark of LANXESS Deutschland GmbH.

Valve and Actuator Sizing

Valve Sizing

The size of butterfly valves which are used for control purposes should not be chosen on the basis of the nominal diameter of the pipe, but should be calculated on the basis of the operating characteristics, in order to achieve the correct control characteristics.

Center Line® Butterfly Valves Series RS are designed with approximately equal percentage characteristics over an opening angle of 60°.

It is necessary only to consider this opening angle when determining the size of a control valve. In determining the valve nominal diameter, firstly calculate the k_v value from the following formulae:

a) for liquids

$$k_v = Q \sqrt{\frac{\gamma}{\Delta p}}$$

b) for gases

$$k_v = \frac{V_N \cdot \sqrt{G \cdot T}}{514 \sqrt{\Delta p \cdot \rho_2}}$$

Where:

- k_v = Flow coefficient
- Q = Maximum flow volume in m³/h
- γ = Specific weight in kg/dm³
- F = Cross-section of pipe in cm²
- Δp = Pressure drop in bar

- V_N = Maximum flow volume in Nm³/h
- G = Specific weight in kg/Nm³
- T = Absolute temperature in °K
- ρ_1 = Absolute pressure upstream in bar
- ρ_2 = Absolute pressure down-stream in bar

Having calculated the k_v value it is now possible to determine the nominal diameter of the valve using the table below.

DN	Cross Section of Pipe F in cm ²	Opening Angle								
		25°	30°	40°	50°	60°	70°	75°	80°	90°
40/50	19,6	5	7	14	23	45	59	76	89	111
65	33,2	8	12	22	35	70	89	111	136	170
80	50,3	12	18	32	53	106	136	175	205	256
100	78,5	23	35	62	102	200	260	341	405	470
125	123	51	75	132	213	418	534	709	854	961
150	177	83	123	213	350	683	880	1153	1410	1666
200	314	145	213	358	598	1111	1495	1880	2329	2777
250	491	222	333	572	982	1837	2350	3076	3675	4273
300	707	324	470	854	1367	2649	3461	4273	5170	6410
350	962	427	641	1111	1880	3504	4358	5726	6923	8547
400	1257	555	769	1452	2264	4358	5555	7692	9230	10683
450	1590	769	1068	1965	3162	6068	7863	10256	11965	14957
500	1963	961	1367	2393	3931	7435	9829	12820	14957	18803
600	2827	1282	1880	3247	5213	10042	14102	17521	20512	23931

Actuator Sizing, Valve Torque and Installation

The following flow velocities should not be exceeded so as to avoid valve noise, vibration and cavitation:

a) for liquids: 4,5 m/sec.

b) for gases: 100 m/sec.

These speeds can be checked by using the following formulae:

a) for liquids

$$C = \frac{Q}{F \cdot 0,36} \text{ in m/sec.}$$

b) for gases

$$C = \frac{V_N \cdot T}{F \cdot \rho_1 \cdot 98,28} \text{ in m/sec.}$$

Actuator Sizing and Valve Torque

The drive torque required when calculating the size of automatic actuators for Center Line® RS butterfly valves can be obtained from the following table:

Shutoff Pressure in bar	Nominal Diameter of a Butterfly Valve (mm)																			
	40/50	65	80	100	125	150	200	250	300	350	400	450	500	600	700	800	900	1000	1200	1400
3,5	-	-	-	31	40	63	115	210	260	420	550	970	1250	2310	3500	4800	6300	8500	10000	*
10	16	23	35	71	95	127	200	280	400	890	1190	1460	1800	3470	5000	7000	9000	11000	12000	*
16	26	38	59	121	180	260	330	480	690	1520	2020	2490	3070	5760	-	-	-	-	-	-

* Consult factory.

The torques apply to liquid and moist media. For dry media they need to be increased.

The torques are listed in Nm. The actuator should be capable of producing the torque listed in the table over the total travel angle.

The closing speed of the actuator must be taken into consideration in order to avoid water hammer when the butterfly valve is installed in pipes conveying a liquid.

The closure period for pneumatic and hydraulic actuators can be achieved by controlling the flow of compressed air or hydraulic fluid. In electrical systems the actuator should be designed by the manufacturer to provide the appropriate closure period.

Instructions for the Installation of Actuators

Center Line® Butterfly Valves Series RS are equipped with a DIN/ISO 5211 flange. The DN 40-300 shaft end is square acc. to DIN 3337. The DN 350-600 shaft is provided with parallel keyway. The shaft dimensions are shown in the following table. An actuator bore with tolerance H11 is recommended.

DN	350	400	450	500	600	700	800	900	1000	1200	1400
Ø	45	45	45	45	70	70	75	85	90	95	100

All Center Line® Butterfly Valves are also available with mounting flange for the transmission to smaller or larger sized DIN/ISO flanges.

Bolt Dimensions

Bolt Dimensions DN 50 - 600

DN	PN	Quantity	For Wafer Bodies Bolt with Nut Thread	Length (mm/inch)	Quantity	For Lug Bodies Bolt with Nut Thread	Length (mm/inch)
50	PN10	4	M16	100	8	M16	35
	PN16	4	M16	100	8	M16	35
	ANSI 150	4	5/8" - 11 UNC	4"	8	5/8" - 11 UNC	1 1/2"
65	PN10	4	M16	110	8	M16	35
	PN16	4	M16	110	8	M16	35
	ANSI 150	4	5/8" - 11 UNC	4"	8	5/8" - 11 UNC	1 3/4"
80	PN10	8	M16	110	16	M16	40
	PN16	8	M16	110	16	M16	40
	ANSI 150	4	5/8" - 11 UNC	5"	8	5/8" - 11 UNC	1 3/4"
100	PN10	8	M16	120	16	M16	40
	PN16	8	M16	120	16	M16	40
	ANSI 150	8	5/8" - 11 UNC	5"	16	5/8" - 11 UNC	1 3/4"
125	PN10	8	M16	120	16	M16	45
	PN16	8	M16	120	16	M16	45
	ANSI 150	8	3/4" - 10 UNC	5 1/2"	16	3/4" - 10 UNC	2"
150	PN10	8	M20	130	16	M20	45
	PN16	8	M20	130	16	M20	45
	ANSI 150	8	3/4" - 10 UNC	5 1/2"	16	3/4" - 10 UNC	2"
200	PN10	8	M20	130	16	M20	50
	PN16	12	M20	130	24	M20	50
	ANSI 150	8	3/4" - 10 UNC	5 1/2"	16	3/4" - 10 UNC	2"
250	PN10	12	M20	150	24	M20	50
	PN16	12	M24	150	24	M24	50
	ANSI 150	12	7/8" - 9 UNC	6 1/2"	24	7/8" - 9 UNC	2 1/2"
300	PN10	12	M20	160	24	M20	60
	PN16	12	M24	160	24	M24	60
	ANSI 150	12	7/8" - 9 UNC	7"	24	7/8" - 9 UNC	2 1/2"
350	PN10	16	M20	160	32	M20	60
	PN16	16	M24	170	32	M24	65
	ANSI 150	12	1" - 8 UNC	8"	24	1" - 8 UNC	2 3/4"
400	PN10	16	M24	180	32	M24	70
	PN16	16	M27	200	32	M27	75
	ANSI 150	16	1" - 8 UNC	9"	32	1" - 8 UNC	2 3/4"
450	PN10	20	M24	200	40	M24	70
	PN16	20	M27	220	40	M27	75
	ANSI 150	16	1 1/8" - 8 UN	10"	32	1 1/8" - 8 UN	3"
500	PN10	20	M24	220	40	M24	70
	PN16	20	M30	240	40	M30	90
	ANSI 150	20	1 1/8" - 8 UN	10"	40	1 1/8" - 8 UN	3"
600	PN10	20	M27	240	40	M27	90
	PN16	20	M33	260	40	M33	100
	ANSI 150	20	1 1/4" - 8 UN	12"	40	1 1/4" - 8 UN	4 1/2"

For weld neck flanges according to EN 1092-1, Type 11, PN10 and PN16 or ANSI 150 B16.5.

CENTER LINE^{RS}

alnab

Alnab Armatur AB
433 86 Partille

Tel +46 31 44 94 50
Fax +46 31 44 24 55
Org. Nr. 556312-9716

alnab@alnab.se
www.alnab.se

reservation för ändringar

www.craneenergy.com

CRANE

Energy Flow Solutions



brands you trust.



COMPAC-NOZ[®]

CRANE[®]

DUO-CHEK[®]



FK[®]
KROMBACH
ARMATUREN
be safe

NOZ-CHEK[®]



STOCKHAM[®]



UNI-CHEK[®]

NUCLEAR

VALVE SERVICES

EG-CE-TB-EN-A16-05-1202 (CV-9)

Crane Co., and its subsidiaries cannot accept responsibility for possible errors in catalogues, brochures, other printed materials, and website information. Crane Co. reserves the right to alter its products without notice, including products already on order provided that such alteration can be made without changes being necessary in specifications already agreed. All trademarks in this material are property of the Crane Co. or its subsidiaries. The Crane and Crane brands logotype (Aloyco[®], Center Line[®], Compac-Noz[®], Crane[®], Duo-Chek[®], Flowseal[®], Jenkins[®], Krombach[®], Noz-Chek[®], Pacific Valves[®], Stockham[®], Triangle[®], Uni-Chek[®]) are registered trademarks of Crane Co. All rights reserved.